

NOTES: UNLESS OTHERWISE SPECIFIED.

1. ALL DIMENSIONS ARE INCHES (±.06) AND MILLIMETERS (±1.) INCHES (mm)

2. LEAVE APPROX. 2" OF CLEARANCE FOR ELECTRICAL CONNECTIONS.

3. PANEL CUT-OUT REQUIRED: 7.06 H. x 8.75 W.
(179.) (222.)

REVISIONS				
REV	DESCRIPTION	DATE	APP.	REV. BY
0	INITIAL RELEASE	11/6/96	VMC	---
1	INC. ECO# 97-0386	5/12/97	A.A.	M.V.

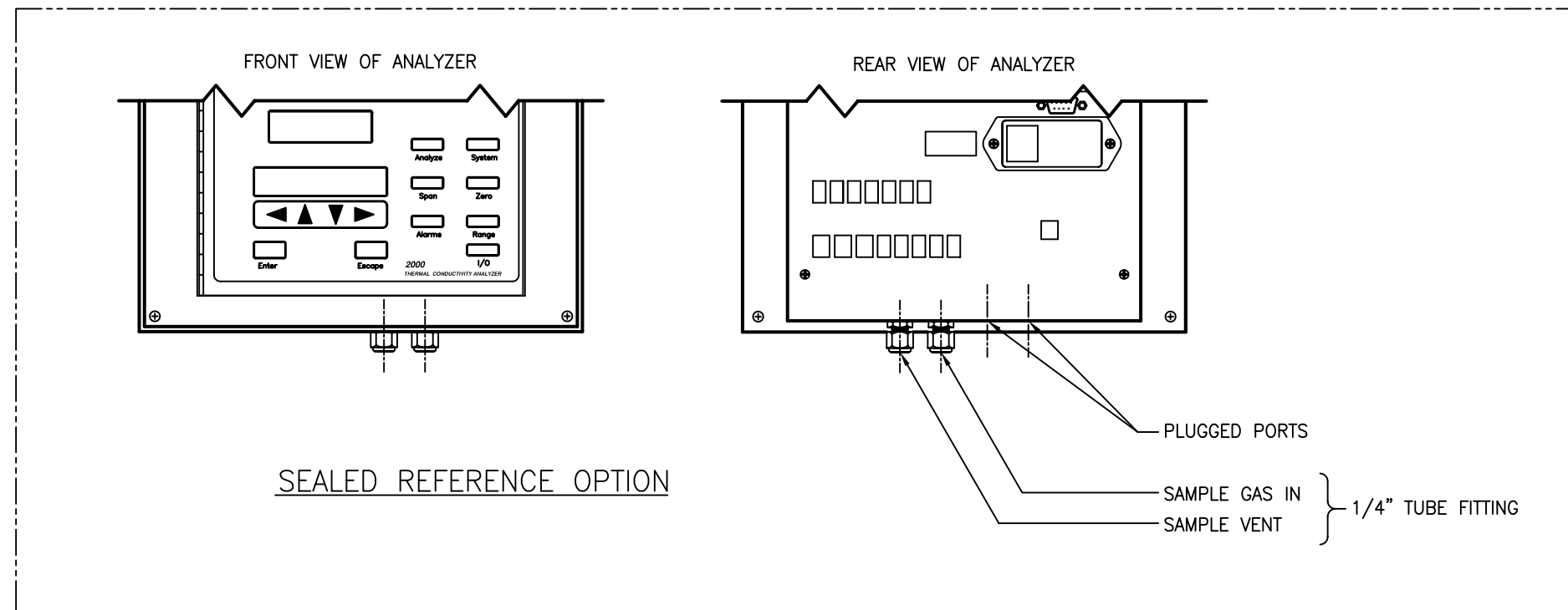
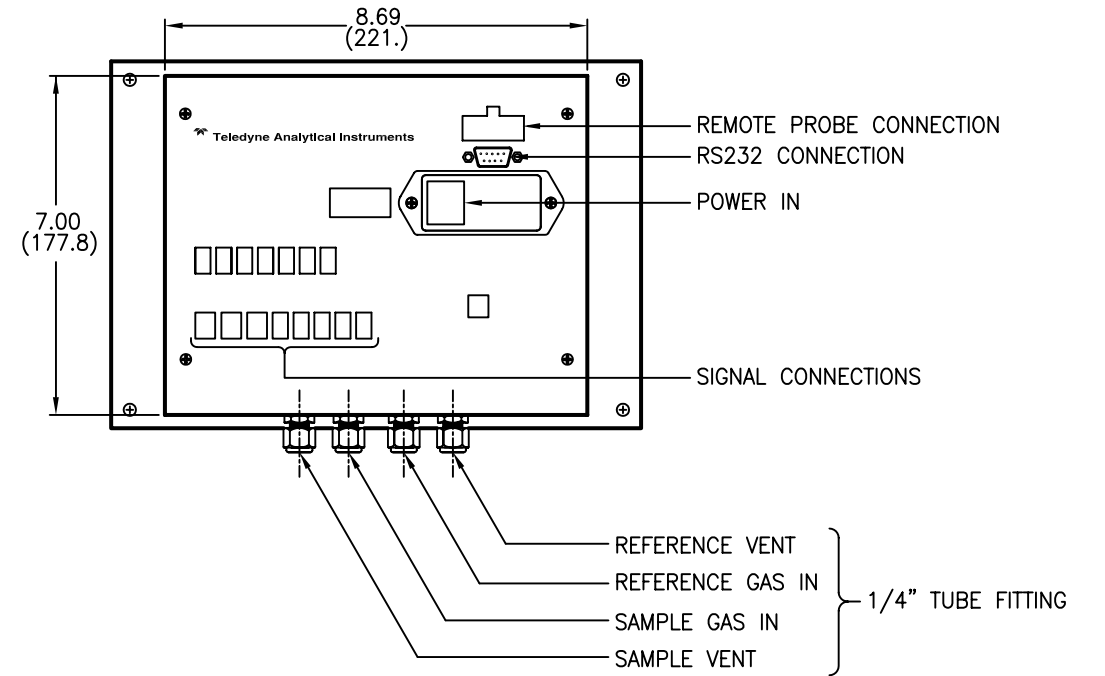
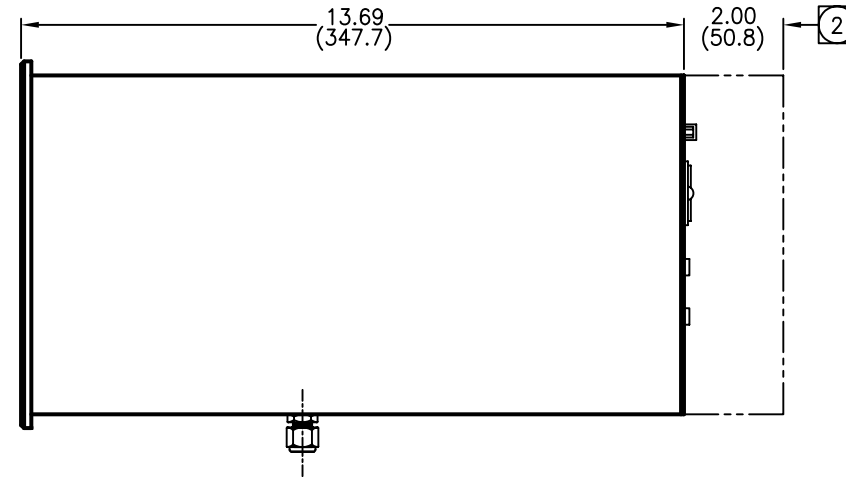
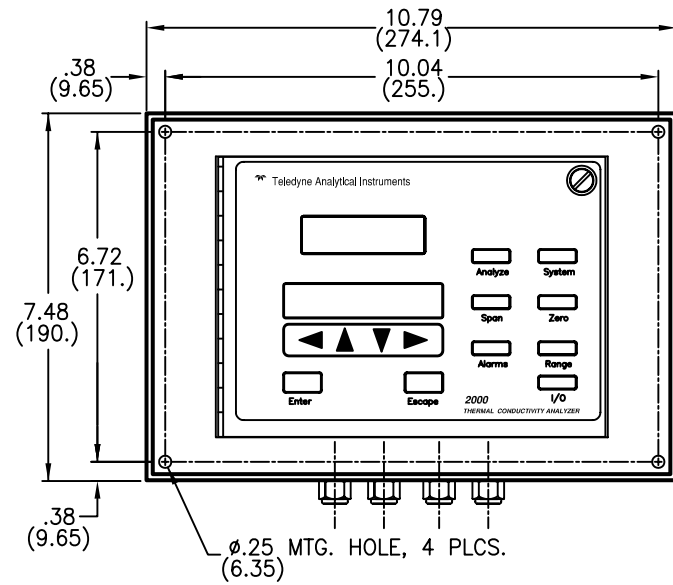

ITEM	QTY	PART NO.	DESCRIPTION
BILL OF MATERIAL			
DO NOT SCALE DWG			
TOLERANCE UNLESS OTHERWISE SPECIFIED: ANGULAR ±1/2°			
LINEAR .XX = ±.1			
.XXX = ±.02			
.XXXX = ±.010			
SIGNATURES		DATE	TITLE
N/	DRFT: JOHN REYES	08/05/96	MDL. 2000 T/C ANALYZER OUTLINE DIAGRAM
I/	CHK:		
O/	APPR:		
P/	ENGR:		
F/	S.O.		
REFERENCE	CAD ID: D67061-1		
MATERIAL: NONE			DWG NO.: D-67061
SCALE: 1:2			REV: 1
SHEET: 1 OF 1			

Teledyne Analytical Instruments
A business unit of Teledyne Electronic Technologies
CITY OF INDUSTRY, CALIFORNIA 91748