

# The Pitfalls of Process TOC

And how to avoid them

## INTRODUCTION

Since the introduction of Total Organic Carbon (TOC) Analyzers by Dow, Union Carbide and Automated Environmental Systems in the 1960s<sup>(1,5)</sup>, they have proven to be an invaluable tool in the environmental and process monitoring fields. While technologies have advanced since then, certain performance characteristics required for true process control have been notably absent.

The purpose of this paper is to discuss those limitations as evidenced by field experience, maintenance requirements and other practical considerations. Failure mode and effect analyses are summarized for critical components, as well as suggested corrective design, operation, and maintenance approaches, with a view toward minimizing cost of ownership.

## BASIC TOC ANALYSIS

Generally, all TOC Analyzers employ the same basic technique as depicted in figure 1. A liquid sample is initially introduced to an Inorganic Carbon (IC) removal stage, where acid is added to the sample, dropping its pH to approximately 2.0. At this point, the IC is converted to carbon dioxide (CO<sub>2</sub>) gas, which is stripped out of the liquid by a sparge carrier gas.

The remaining inorganic carbon-free sample is then delivered to the Oxidation Chamber. The Oxidation Chamber is normally either a chemical reagent (Persulfate) with an Ultraviolet (UV) Lamp Reactor<sup>(4)</sup> or a High Temperature Combustion Reactor<sup>(3)</sup> for catalytic or non-catalytic oxidation. The Reactors oxidize the remaining organic carbon to CO<sub>2</sub> gas, which is directed to and measured by the CO<sub>2</sub> gas detector. The CO<sub>2</sub> gas detector is a Non-Dispersive-Infrared Analyzer (NDIR), to meet EPA and ASTM Standards<sup>(3,4)</sup> and provide interference-free detection of CO<sub>2</sub> gas. The CO<sub>2</sub> generated from the oxidation process is directly related to the TOC in the sample.

While the principle objective of this paper is to provide a guide to avoid common TOC operational problems, a brief description of the chemical analysis should be given since there has been some unnecessarily complicated treatment of sub-categories of organic carbon.

Quite simply, do you need to measure volatile and purgeable organic carbon, as well as dissolved and suspended-solid organic carbon, for a "true" TOC analysis or not? If only the dissolved and suspended solid TOC are of interest, categorized as "NPOC" (Non-Purgeable-Organic-Carbon), then a "TOCDIRECT" measurement will suffice. Figure 1 illustrates the "TOCDIRECT" method. It indicates the physical effect of flowing a sparge carrier gas through the INORGANIC CARBON SPARGER to strip out the dissolved CO<sub>2</sub>, created by the acidification process to remove the inorganic carbon from the sample, as previously described.

Note that "POC" (Purgeable Organic Carbon) and "VOC" (Volatile Organic Carbon) are also stripped out and lost to analysis. If the measurement of all the organic carbon is required, then a "TOCTRUE" analysis must be made.

Figure 2 shows both the "TOCDIRECT" and "TOCTRUE" methodologies. In the TOC true method, both the CO<sub>2</sub> gas from the SPARGER and the CO<sub>2</sub> gas generated from oxidizing the complete sample are measured. A computed differential measurement yields all of the organic carbon content for a complete, or "TRUE", TOC analysis.

Aside from pure process control requirements, Regulatory Agencies may require analysis of all the organic carbon species for the discharged waste water.

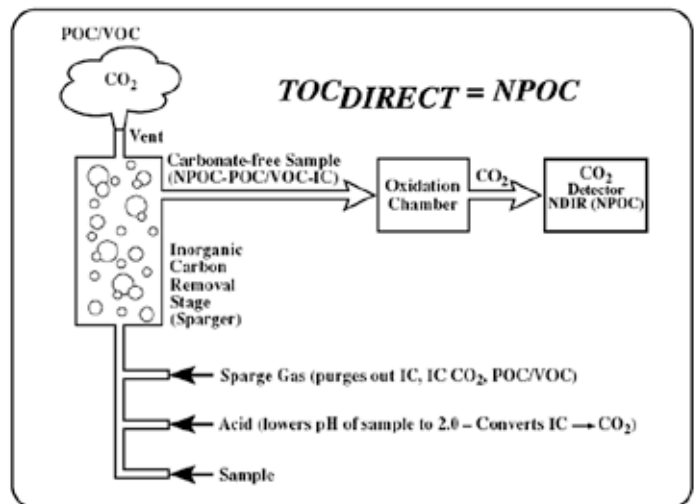

Figure 1

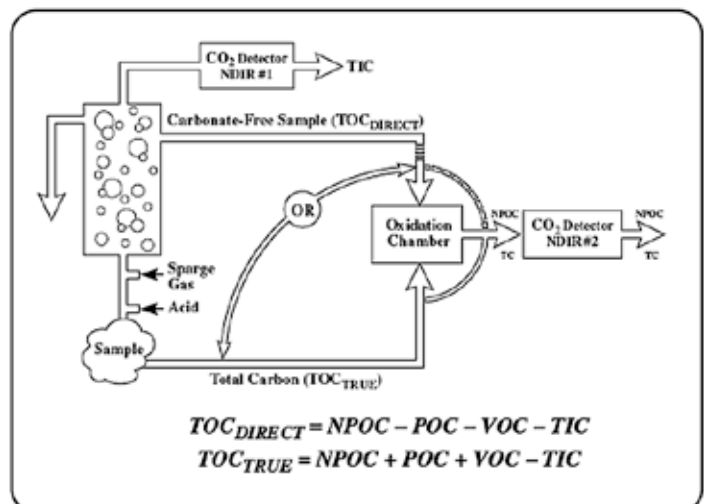

Figure 2

**OXIDATION METHOD**

**(Do I select UV/PERSULFATE or HIGH TEMPERATURE COMBUSTION?)**

After determination of the “TOCDIRECT” and “TOCTRUE” question, the important choice of oxidation method must be made. While the details of this subject exceed the scope of this paper, the existing basic “rule of thumb” may be stated as:

- a) For low level TOC analysis, undiluted ranges up to 2000 ppm (parts-per-million) carbon, no salts (or diluted to a very low level), and significantly less maintenance, UV/PERSULFATE oxidation should be chosen.
- b) For difficult-to-oxidize or salt-containing samples, high levels of carbon, or method preference, HIGH TEMPERATURE COMBUSTION should be selected for those applications.

**FAILURE MODES AND EFFECTS**

In order to clarify potential failure points and for purposes of illustration, a conventional Process UV/Persulfate TOC is shown in figure 3<sup>(12)</sup>. Figure 4 depicts a conventional High Temperature Combustion TC (Total Carbon) / TOC Analyzer.<sup>(10)</sup>

Table 1 defines summary failure modes and effects, along with suggested improvements for added system reliability and “fail-safe” operation of the critical systems / subsystems.

**SAMPLE SYSTEM**

As in any liquid analyzer, the sample system is critical. It must be controlled for stability but, most importantly, the sample must be present where it should be, in the volume/flow required. Loss of sample is therefore deemed a critical monitoring and alarm category. It should be measured in two locations:

At the Sparger (Scrubber)/sample by-pass loop

AND

At the outlet of the Reactor in UV/PERSULFATE systems

OR

After syringe or aspirated sample is delivered to a High Temperature Reactor

Pitfall (Ref. FAILURE MODES AND EFFECTS Table 1)

- 1) If loss of sample is not measured at the Sparger, a clogged sample tube at the Sparger inlet would only allow passage of the acid reagent and loss of sample would not be detected at the Sparger outlet. A liquid flow sensor only at the Sparger outlet or the Reactor inlet would then erroneously detect the acid as “sample.”
- 2) If loss of sample is not also detected at the outlet of the Reactor of a UV/PERSULFATE TOC Analyzer (and not just the inlet, as is sometimes done), a clogged Reactor or line leak downstream of the sensor would not be detected and cause erroneous results.

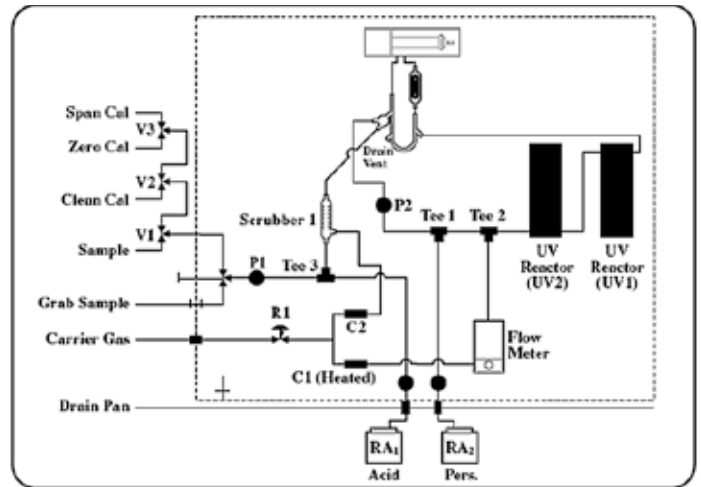

Figure 3

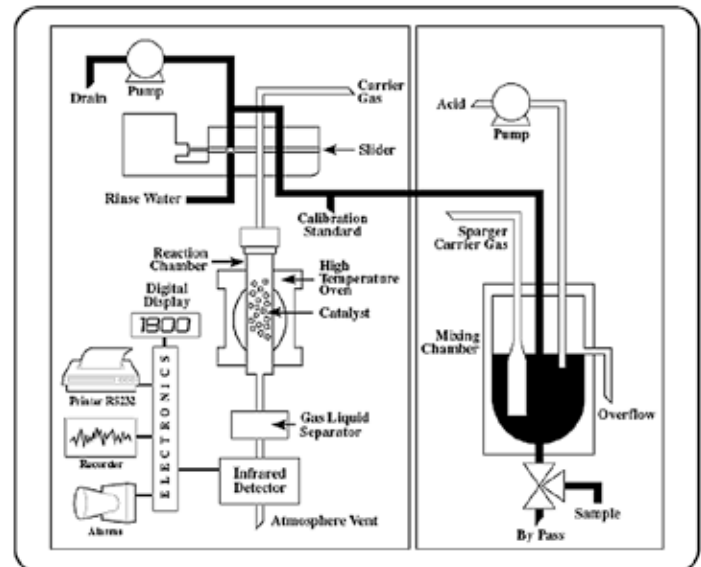

Figure 4

3) If the actual sample going into the High Temperature Reactor is not actually measured, complete reliance of exact sample size delivery (and therefore TOC “value”) is entrusted to a failure-prone mechanical device (syringes jam, get air bubbles and leaks; aspirated microliter samples from a slider valve get salt buildups, seal leaks, etc.).

This is considered an important monitoring point, because proper analyzer operation can otherwise only be inferred by the observance of additional multiple “peak shapes” and tested by frequent calibrations.

**TABLE I - FAILURE MODES AND EFFECTS**

(see "Pitfalls" for corresponding paragraphs)

System/Subsystem	Failure Modes	Failure Effects	Fail-Safe Requirement
SAMPLE SYSTEM	1. Malfunction of facility sample delivery system. Sparger inlet clogs; is damaged.	Loss of sample is undetected. Loss of data. Partial loss (clog) not detected until calibration	Loss-of-Sample detector at sparger
	2., 3. Reactor, Sample Lines Clog or Leak.	Unreliable or complete loss of data	Loss-of-Sample detector at OUTLET of UV/Persulfate Reactor or AFTER injection into High Temperature Combustion Reactor
	4. Acid Reagent lost, due to line/pump failure or out of Acid	IC not removed, resulting in unreliable data.	Acid Reagent Consumption Monitored
	5. Persulfate Reagent lost, due to line/pump failure or out of Persulfate.	Incomplete Oxidation, resulting in unreliable data.	Persulfate Reagent Consumption Monitored
	6. Fitting/Sample Line leaks	Severe damage to analyzer and components.	Analyzer Leak Detector with automatic shutdown of Liquid sample system
Carrier Gas	Unstable Gas Flow due to varying upstream pressure or downstream clog or partial clog.	Unreliable Data, damage to Flow Control Components.	Loss-of-Carrier Detector and Automatic shutdown of sample pumps, etc.
REACTORS			
UV/Persulfate	1. UV Lamp Ages, losing required Power Spectral Density.	Degradation of data and unreliable TOC results	Certification of Lamp Initial Power Spectral Density and automatic predictive maintenance ALERT
	1. Component Failures if exceed Temperature Limits.	Destruction of components	Automatic detection and shutdown in event of over-temperature condition
High Temperature Combustion	2. Catalyst Poisoning	Unreliable data	Monitor/Reactivate Catalyst, or repack combustion tube
	3. Reactor clog/partial clog.	Unreliable or complete loss of data	Reactor/Line Clog Detector
	4. STRUCTURAL Failure (crack, etc.)	Unreliable or complete loss of data, analyzer damage	Reactor structural integrity monitor
Non-Dispersive-Infrared Analyzer (NDIR)	Failure or Slow Degradation of Following Components: 1. Mechanical Choppers (if used) 2. Infrared Sources 3. Infrared Detectors 4. Corrosion/dirt buildup on optical surfaces	Unpredictable Drift, inaccurate data	"FAIL-SAFE" design with alarm in event of malfunction of any critical component or sample effect (corrosion/dirt)
RANGES	1. Multi-range performed by electronic scaling	Inaccurate data at lower range	Two (or more) truly distinct ranges, each calibrated "full-scale" with designated "full-scale" chemical calibration standard solutions
	2. Over-Range	Inaccurate data (could have severe consequences in some UV/Persulfate applications)	"Fail-safe" over-range monitoring, control and compensation

## REAGENTS

Loss of reagents is considered a critical malfunction and must be monitored for on-line applications.

Pitfall:

- 4) If the acid reagent is lost, the Inorganic Carbon will not be removed and is an interferent to TOC analysis, presenting measurements in excess of the actual TOC in the sample.
- 5) If the persulfate reagent is lost in the UV/Persulfate system, the TOC values reported will be significantly less than the actual TOC of the sample, except for ultra-pure water applications.
- 6) If any fitting / sample line leak occurs, the analyzer and components could be severely damaged.

## CARRIER GAS

Oxygen, air or nitrogen may be used as carrier gas. The Carrier must be stable and controlled as a critical parameter, otherwise gross inaccuracies will occur. The CO<sub>2</sub> created in the oxidation process of the Reactor is measured by the NDIR as a volume percent of the total Reactor exit gases:

$$\frac{(\text{CO}_2)}{\text{carrier} + \text{CO}_2 \text{ generated}}$$

Thus, if the carrier gas flow varies (e.g., by fluctuating upstream supply pressure or downstream variations occurring due to a partial clog), TOC analysis would have a corresponding error. (The measurement and control of the actual flow by a Mass & Flow Controller is preferred, rather than a pressure-derived method to avoid this pitfall).

From a maintenance standpoint, loss of carrier gas can have a catastrophic failure effect on analyzer components. In the UV/Persulfate Reactor, corrosive persulfate, acid and sample would be forced up into capillaries, pressure gages and flowmeters, if used. Check valves are of limited benefit, generally lasting only one such malfunction before being ruined by the corrosive reagents and sample. Thus, loss of carrier flow is considered a mandatory monitoring and alarm point.

## REACTORS

This critical subsystem must have malfunction detection. Both UV/PERSULFATE and HIGH TEMPERATURE COMBUSTION REACTORS have critical aspects which include the following:

### UV/PERSULFATE REACTOR:

The most critical aspect of this Reactor is the UV lamp. Power spectral density of 185 nm (nanometers) and 254 nm must be sufficient to break the carbon bonds and fully oxidize the carbon to CO<sub>2</sub> gas.<sup>(7,9)</sup>

PITFALL

UV lamps must be certified by the analyzer manufacturer to have sufficient 185 nm and 254 nm energy and have an automatic

predictive maintenance alert to replace worn lamps, based on actual test data. If there is insufficient UV energy, incomplete carbon oxidation will occur, resulting in erroneous and costly errors.

### HIGH TEMPERATURE COMBUSTION REACTOR:<sup>(7)</sup>

While this oxidation method may offer advantages over UV/PERSULFATE Reactors in some applications, because of its high temperature components and the use of catalyst, it inherently presents added failure modes and more maintenance requirements than the UV/PERSULFATE REACTOR

PITFALLS:

- 1) Furnace temperature must be controlled and monitored. Mandatory automatic "overttemperature" alarm and shutdown must occur, otherwise the REACTOR /FURNACE ASSEMBLY will be destroyed when these components exceed their temperature limits.
- 2) Catalyst poisoning must be monitored, otherwise erroneous results will occur. This is considered mandatory for reliable operation.
- 3) Reactor clogging must be monitored as mandatory for on-line analysis.
- 4) Reactor Assembly must be continuously monitored for structural integrity and subsystem leaks, otherwise destruction of components as well as loss of data will occur.

### NON-DISPERSIVE-INFRARED ANALYZER<sup>(7,8,11)</sup>

Most TOC analyzer "drift" is associated with the NDIR. It is the "heart" of the analyzer and is, in itself, also an analyzer subject to all related instrumental performance anomalies. Although still useful in controlled laboratory conditions, vintage "Luff" type detectors, in use since the 1940s, have proven insufficient to operate drift-free in plant environments long-term, due to difficulty of implementing onboard diagnostics and compensation<sup>(8)</sup> for drift.

PITFALLS

The NDIR must have a "FAIL-SAFE"<sup>(6,8)</sup> operation. It must alarm in the event of malfunction of critical components. These include:

- 1) Failure of mechanical choppers, if used (mandatory)
- 2) Loss or degradation of infrared sources (mandatory)
- 3) Loss or degradation of infrared detectors (mandatory)
- 4) Compensation for corrosion and contamination of optics (mandatory)

If the NDIR is not self-compensated for drift caused by the above and other inherent potential malfunctions, frequent calibrations must be performed.

## DATA PROCESSING AND CONTROL ELECTRONICS

To offer the capability demanded for modern process control, there is no substitute for the power of an onboard industrial computer. Microprocessors programmed with proprietary software in eproms, while serving a useful purpose in the past<sup>(2)</sup>, are inadequate for today's chemical processes and reasonable analyzer maintenance support.

Additionally, the computer offers bi-directional control, ability to perform self diagnostics with predictive maintenance alerts and can offer operational flexibility with no Operator manual adjustments<sup>(6)</sup>.

### PITFALLS

The electronics should be separated physically from the liquid handling compartments to avoid damage by leaks or corrosion. Assuming proper choice of this subsystem for onboard analyzer control and the provision of standard analyzer outputs, the Analyzer/Control Room interface represents a major area where attention to detail must be given. Specifically, the following analyzer signals should be presented to the Control Room (or analyzer technician):

- a) "Run" Status
- b) "Off- Line / In- Calibration" Status
- c) Benchmark "Passed/Failed" Status
- d) "Loss-of-Sample" Alarm
- e) "Loss -of-Reagent" Alarm
- f) Analyzer "Leak" Alarm
- g) "Loss- of- Carrier" Alarm
- h) Reactor "Malfunction" Alarm
- i) NDIR "Malfunction" Alarm
- j) "Overrange"/"Underrange" Alarm

## RANGES

The important question of range selection and implementation pitfalls must be addressed. Typically, in monitoring a process, the TOC is used within nominal limits until a process "upset" occurs, during which time the TOC values may increase over ten-fold.

The Plant Operator wants both maximum precision in the normal operating range and the ability to track TOC during the "upset", in order to better control the process.

### PITFALLS

1. If just an electronic scaling were done for the two ranges, the Operator would suffer the inaccuracies at the lower, normal operating range attributed to the "full-scale" higher TOC range. The analyzer would typically be chemically calibrated "full-scale" at the highest range with, for example, a  $\pm 2\%$  full-scale repeatability. If the higher range used in a process upset were 0 -10,000 ppm and if the normal range were 0-1,000 ppm, the consequent inaccuracy at the

normal operating range would be  $1,000 \pm 200$  ppm, or  $\pm 20\%$  of the actual TOC value (and the analyzer would still be "in spec").

2. Far greater consequences can occur. For example, in a UV/PERSULFATE analyzer, the phenomena of "carbon-loading" and competing reactions can actually result in a "down-turn" of analyzer TOC results, with reported TOC data being significantly lower than actual.

To avoid this pitfall, two truly distinct ranges, each calibrated "full-scale" with appropriate different chemical calibration solutions should be used. This would then afford far greater precision of control parameters for the Plant Operators to optimize their processes, since each range would be of equivalent instrument "Full-Scale" accuracy.

## CALIBRATION

Calibration requests represent the single most costly analyzer maintenance category.<sup>(6)</sup> Understandably, during a process spill or upset, Plant Operators seek the best available data before making critical decisions and will often ask for immediate instrument recalibration, especially if they lack confidence in the analyzer's performance.

The problem is that conventional TOC calibration techniques may require the analyzer to be out of service for over an hour, just when the Plant Operator needs the most accurate data in a timely fashion. "AUTOCALIBRATION" may sound appealing but, like manual calibration, it takes just as long, must still be monitored by qualified personnel, and offers little advantage to Plant Operators.

All calibration is only a temporary, marginal solution for process control analyzers if there are imprecise or lack of adequate analyzer onboard self-diagnostics as to its instantaneous and continuing proper operation. It only masks any basic analyzer problem and merely "resets" it to a new "calibrated" condition, without any ability to accurately judge analyzer past performance, validity of previous data, or give any assurance of future reliability.<sup>(6)</sup>

### "What is the best, most cost effective strategy for TOC analyzer calibration?"

With the advent of advanced, computer-controlled instrumentation, greater emphasis is now being placed on rapid, yet accurate, continuous self diagnosis and analyzer self-correction techniques.

Highly productive European and U.S. Plants are now starting to implement a strategy which involves what is commonly referred to as "Benchmark." Benchmark is a more sophisticated version of a "calibration check", used in the past with varying success. A known TOC chemical calibration standard solution is programmed to be automatically introduced to the analyzer. The output is checked and referenced to a prior calibration. The analyzer then outputs whether the analyzer "passed" or "failed" (and by how much).

For example, if the analyzer was within 2% of the last calibration, the analyzer is judged to be working within specification. If the Benchmark "fails", Plant rules may require a visual inspection or the

analyzer could be programmed to automatically reset itself to a fully calibrated condition - all within 10 minutes.

Auto-cleaning sample lines could also be accomplished during this time period. Thus, calibration becomes an "ON-DEMAND" operation. Benchmark could be scheduled to be performed automatically or done manually. Should the Plant Operator question the validity of current TOC data, a Benchmark could immediately be initiated in the Control Room by a simple switch actuation. Analyzer performance is greatly enhanced and the conservation of manpower, time, and cost is also dramatically increased.

**COST OF OWNERSHIP**

Cost of ownership includes not only the initial analyzer purchase but also related operational costs (consumables, spare parts, maintenance, etc.).

**Initial Purchase**

It is well advised to include the cost of analyzer self-diagnostics and fail-safe alarm packages, resulting in considerably reduced costs of maintenance.<sup>(6)</sup>

**Consumables**

The cost of chemical standard solutions and reagent preparation should be included in addition to reagent consumption. In the UV/Persulfate TOC, consumable costs include acid and persulfate reagents and the UV lamp. In the High Temperature combustion TOC, consumable costs include acid and catalyst.

**Maintenance**

By far, maintenance is the major contributor to past TOC analyzer expense. After calibration, the biggest instrument cost of ownership is the in-plant repair and the administration and storing of the spare parts inventory. When the major components (modules) of an instrument can be easily disconnected and reconnected with an exchanged module from the Analyzer supplier without special tools, maintenance costs are drastically reduced.<sup>(6)</sup>

Forward thinking users are demanding the following:

MODULAR CONSTRUCTION for replacement of parts without special tools and no in-plant repair.

AUTOMATIC OPERATION with little or no Operator manual adjustments

ANALYZER SELF-DIAGNOSTICS, appropriate alarm packages and the ability to self-monitor and only require "MAINTENANCE ON DEMAND"

Figures 5 and 6, respectively, present alternate approaches to conventional High Temperature combustion and UV/Persulfate Oxidation TOC Analyzers.

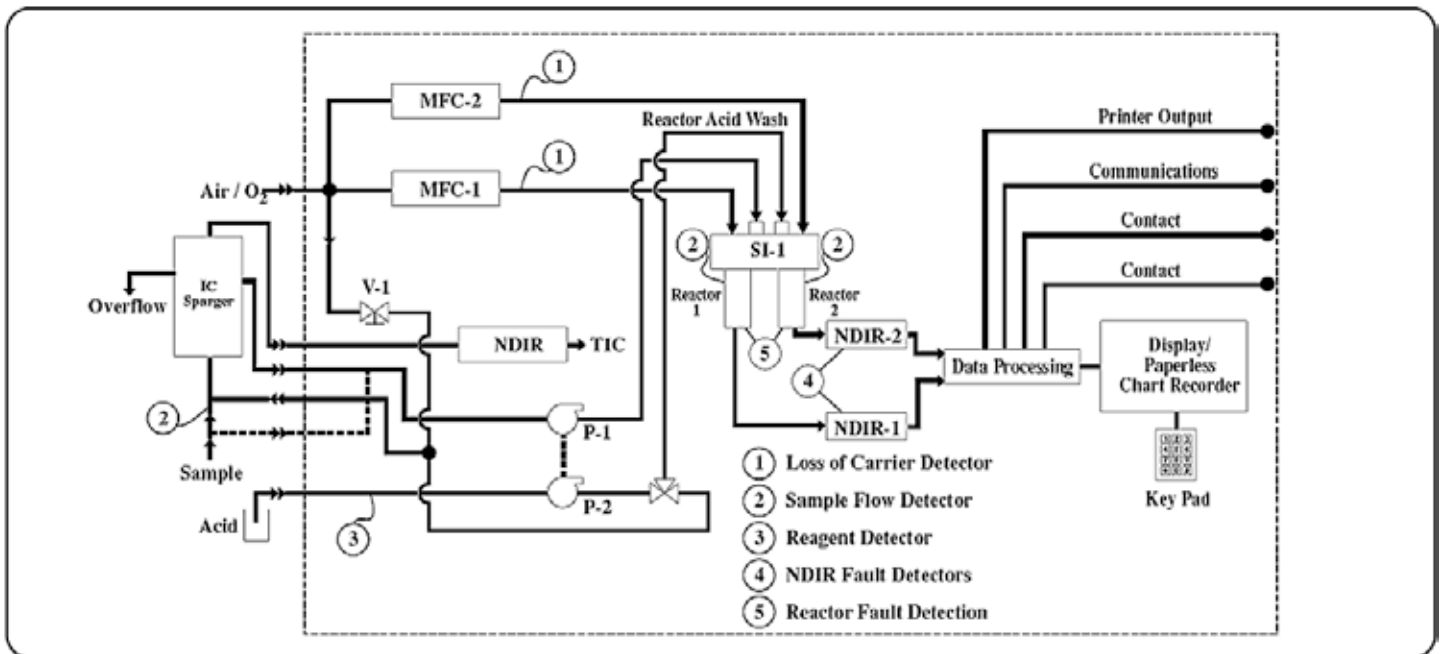

Figure 5

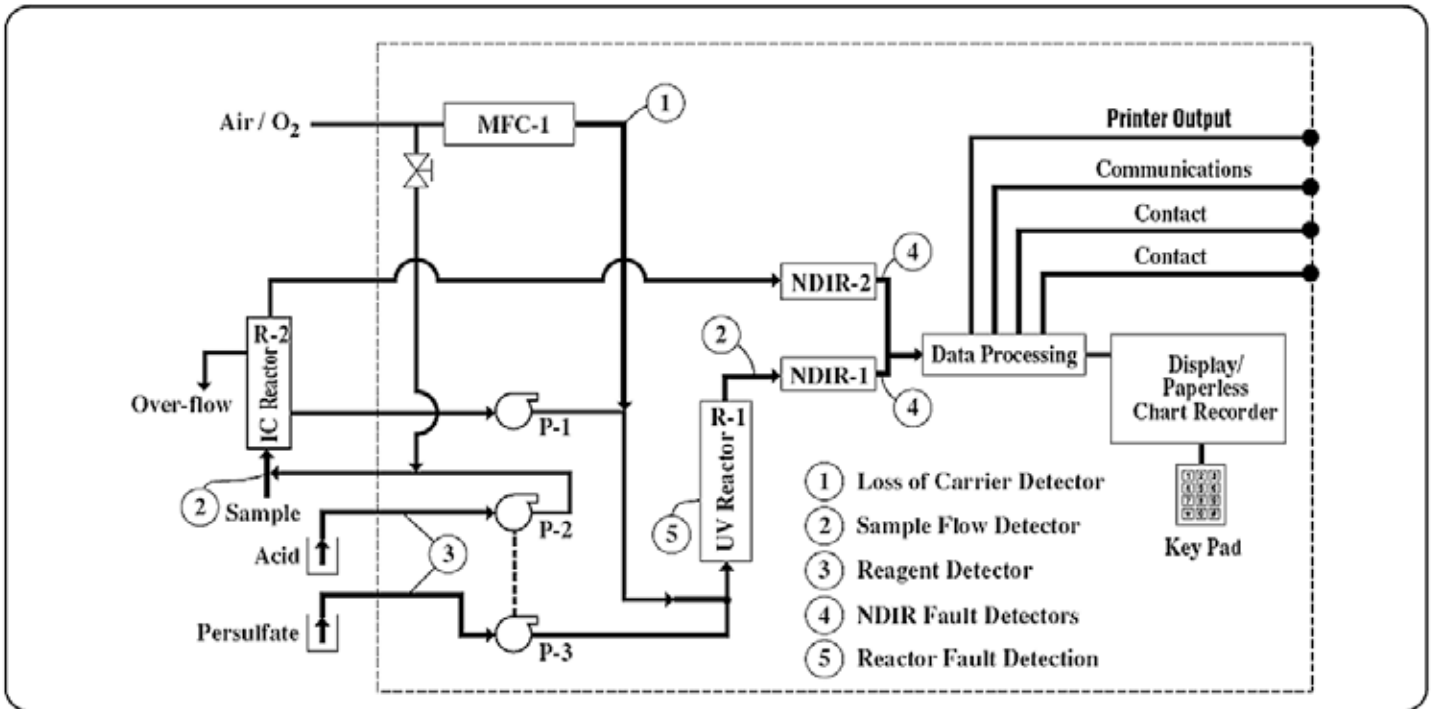

Figure 6

### SUMMARY AND CONCLUSIONS

If properly configured and applied, TOC analyzers offer a unique capability to support a wide range of applications. Intelligent analyzer design and construction to minimize maintenance and cost of ownership is achievable with modern technology.

Significant cost savings can be derived from a novel approach to the provision and management of spares by adopting a module exchange program, whereby faulty components are not repaired in-plant but are “exchanged” in modular form by the manufacturer for easy installation by Operators.

Chart 1 provides the reader with a check list to assure the analyzer selected and the installation provides the necessary features to avoid the many pitfalls of TOC analysis.

### TOC ANALYZER SELECTION CHECKLIST

1. TOC TRUE METHOD? \_\_\_\_\_
2. TOC DIRECT METHOD? \_\_\_\_\_
3. CRITICAL SINGLE POINT FAILURES IDENTIFIED? \_\_\_\_\_
4. NECESSARY COMPONENT REDUNDANCY FOR CONTINUOUS, ON-LINE OPERATION? \_\_\_\_\_
5. ADEQUATE ANALYZER SELF-DIAGNOSTICS? \_\_\_\_\_
6. MODULAR CONSTRUCTION FOR EASE OF EXCHANGING PARTS, WITHOUT THE USE OF SPECIAL TOOLS (NOT REQUIRING IN-PLANT REPAIR)? \_\_\_\_\_
7. ANALYZER LEAK DETECTOR? \_\_\_\_\_
8. ADEQUATE LOSS-OF-SAMPLE DETECTION (SPARGER, REACTOR, ETC.)? \_\_\_\_\_
9. LOSS-OF-REAGENT DETECTION? \_\_\_\_\_
10. LOSS-OF-CARRIER GAS DETECTION? \_\_\_\_\_
11. ADEQUATE REACTOR DIAGNOSTIC AND FAILURE REPORTING? \_\_\_\_\_
12. NDIR A "FAIL-SAFE" CO<sub>2</sub> DETECTOR? \_\_\_\_\_
13. ON BOARD TOC ELECTRONICS COMPATIBLE WITH CONTROL ROOM? \_\_\_\_\_
14. ELECTRONICS PHYSICALLY SEPARATED FROM LIQUID HANDLING SYSTEM? \_\_\_\_\_
15. ADEQUATE "BENCHMARK"/"AUTO-CALIBRATION" AVAILABLE? \_\_\_\_\_
16. "TRUE" MULTI-RANGE APPROACH (IF REQUIRED)? \_\_\_\_\_

Chart 1

ab0004 0606/LD

### REFERENCES

1. Small, J.W., "All About TOC Analyzers", Poll. Eng. 12(9),63-65(1980)
2. Safranko, J.W., Schuler, J.D., and Small, J.W., "A Low-Temperature Microprocessor-Controlled TOC Analyzer" Am. Lab. 15(8), 56-65(1983).
3. EPA Standard Method 415.1 for catalytic combustion TOC analysis.
4. EPA Standard Method 415.1 for wet chemical oxidation TOC analysis.
5. Van Hall, C., Safranko, J., and Stenger, V., Anal.Chem 35,319(1963).
6. McMillan, G.K., Merz, G.E., and Trevathan, V.L. "Troublefree Instrumentation", Chem. Eng. 82-94(Nov., 1998).
7. Small, R.A., Lowry, T.W., and Eizak, E.M., "Oxidation and Detection Techniques in TOC Analysis", American Laboratory (141-150) (Feb., 1986) and International Laboratory (56- 67) (May, 1986).
8. Small, J.W., "Monitoring Of Combustible Gases-New Open Cell IR Detector Is Fail-Safe", Measurements and Control (148-151) (June, 1988).
9. Small, J.W., Verostko, C.E., Linton, A.T., and Burchette. "Recent Development in Water Quality Monitoring for Space Station Reclaimed Wastewaters", SAE 17th Intersociety Conference on Environmental Systems, July 13-15, 1987.
10. Queeney, K.M., and Hoek, F.B., "On-Line Determination of Organic Pollutants Using TOC, TC, TOD and COD" IONICS, Inc. Reprint, American Laboratory (October, 1989).
11. Small, J.W., and Odegard, W.L., "New Advances in Non-Dispersive IR Technology for CO<sub>2</sub> Detection", SAE 18th Intersociety Conference on Environmental Systems, July 11-13, 1988.
12. Zellweger/Astro Product Literature