

Use and Disclosure of Data
Information contained herein is classified as EAR99 under the
U.S. Export Administration Regulations.
Export, reexport or diversion contrary to U.S. law is prohibited.

INSTRUCTION MANUAL

Model 9110T

Nitrogen Oxides Analyzer



P/N M9110T
DATE 12/01/14

TELEDYNE ELECTRONIC TECHNOLOGIES

Analytical Instruments

16830 Chestnut Street
City of Industry, CA 91748
Telephone: (626) 934-1500
Fax: (626) 961-2538

Web: www.teledyne-ai.com

Copyright © 2014 Teledyne Analytical Instruments

All Rights Reserved. No part of this manual may be reproduced, transmitted, transcribed, stored in a retrieval system, or translated into any other language or computer language in whole or in part, in any form or by any means, whether it be electronic, mechanical, magnetic, optical, manual, or otherwise, without the prior written consent of Teledyne Analytical Instruments, 16830 Chestnut Street, City of Industry, CA 91748.

Warranty

This equipment is sold subject to the mutual agreement that it is warranted by us free from defects of material and of construction, and that our liability shall be limited to replacing or repairing at our factory (without charge, except for transportation), or at customer plant at our option, any material or construction in which defects become apparent within one year from the date of shipment, except in cases where quotations or acknowledgements provide for a shorter period. Components manufactured by others bear the warranty of their manufacturer. This warranty does not cover defects caused by wear, accident, misuse, neglect or repairs other than those performed by Teledyne or an authorized service center. We assume no liability for direct or indirect damages of any kind and the purchaser by the acceptance of the equipment will assume all liability for any damage which may result from its use or misuse.

We reserve the right to employ any suitable material in the manufacture of our apparatus, and to make any alterations in the dimensions, shape or weight of any parts, in so far as such alterations do not adversely affect our warranty.

Important Notice

This instrument provides measurement readings to its user, and serves as a tool by which valuable data can be gathered. The information provided by the instrument may assist the user in eliminating potential hazards caused by his process; however, it is essential that all personnel involved in the use of the instrument or its interface be properly trained in the process being measured, as well as all instrumentation related to it.

The safety of personnel is ultimately the responsibility of those who control process conditions. While this instrument may be able to provide early warning of imminent danger, it has no control over process conditions, and it can be misused. In particular, any alarm or control systems installed must be tested and understood, both as to how they operate and as to how they can be defeated. Any safeguards required such as locks, labels, or redundancy, must be provided by the user or specifically requested of Teledyne at the time the order is placed.

Therefore, the purchaser must be aware of the hazardous process conditions. The purchaser is responsible for the training of personnel, for providing hazard warning methods and instrumentation per the appropriate standards, and for ensuring that hazard warning devices and instrumentation are maintained and operated properly.

Teledyne Analytical Instruments, the manufacturer of this instrument, cannot accept responsibility for conditions beyond its knowledge and control. No statement expressed or implied by this document or any information disseminated by the manufacturer or its agents, is to be construed as a warranty of adequate safety control under the user's process conditions.

Trademarks

All trademarks, registered trademarks, brand names or product names appearing in this document are the property of their respective owners and are used herein for identification purposes only.

SAFETY MESSAGES

Important safety messages are provided throughout this manual for the purpose of avoiding personal injury or instrument damage. Please read these messages carefully. Each safety message is associated with a safety alert symbol, and are placed throughout this manual and inside the instrument. The symbols with messages are defined as follows:



WARNING: Electrical Shock Hazard



HAZARD: Strong oxidizer



GENERAL WARNING/CAUTION: Read the accompanying message for specific information.



CAUTION: Hot Surface Warning



Do Not Touch: Touching some parts of the instrument without protection or proper tools could result in damage to the part(s) and/or the instrument.



Technician Symbol: All operations marked with this symbol are to be performed by qualified maintenance personnel only.



Electrical Ground: This symbol inside the instrument marks the central safety grounding point for the instrument.

CAUTION
GENERAL SAFETY HAZARD

The T100 Analyzer should only be used for the purpose and in the manner described in this manual. If you use the T100 in a manner other than that for which it was intended, unpredictable behavior could ensue with possible hazardous consequences.

NEVER use any gas analyzer to sample combustible gas(es).

Note

Technical Assistance regarding the use and maintenance of the 9110T or any other Teledyne product can be obtained by contacting Teledyne's Customer Service Department:

Phone: 626-934-1500

Email: ask_tai@teledyne.com

or by accessing various service options on our website at

<http://www.teledyne-ai.com/>.

CONSIGNES DE SÉCURITÉ

Des consignes de sécurité importantes sont fournies tout au long du présent manuel dans le but d'éviter des blessures corporelles ou d'endommager les instruments. Veuillez lire attentivement ces consignes. Chaque consigne de sécurité est représentée par un pictogramme d'alerte de sécurité; ces pictogrammes se retrouvent dans ce manuel et à l'intérieur des instruments. Les symboles correspondent aux consignes suivantes :



AVERTISSEMENT : Risque de choc électrique



DANGER : Oxydant puissant



AVERTISSEMENT GÉNÉRAL / MISE EN GARDE : Lire la consigne complémentaire pour des renseignements spécifiques



MISE EN GARDE : Surface chaude



Ne pas toucher : Toucher à certaines parties de l'instrument sans protection ou sans les outils appropriés pourrait entraîner des dommages aux pièces ou à l'instrument.



Pictogramme « technicien » : Toutes les opérations portant ce symbole doivent être effectuées uniquement par du personnel de maintenance qualifié.



Mise à la terre : Ce symbole à l'intérieur de l'instrument détermine le point central de la mise à la terre sécuritaire de l'instrument.

MISE EN GARDE



Cet instrument doit être utilisé aux fins décrites et de la manière décrite dans ce manuel. Si vous utilisez cet instrument d'une autre manière que celle pour laquelle il a été prévu, l'instrument pourrait se comporter de façon imprévisible et entraîner des conséquences dangereuses.

NE JAMAIS utiliser un analyseur de gaz pour échantillonner des gaz combustibles!

ABOUT THIS MANUAL

This manual describes operation, specifications, and maintenance for the Model 9110T.

In addition this manual contains important SAFETY messages for this instrument. It is strongly recommended that you read that operation manual in its entirety before operating the instrument.

ORGANIZATION

This manual is divided among three main parts and a collection of appendices at the end.

Part I contains introductory information that includes an overview of the analyzer, specifications, descriptions of the available options, installation and connection instructions, and the initial calibration and functional checks.

Part II comprises the operating instructions, which include initial functional checks and calibration, basic, advanced and remote operation, advanced calibration, diagnostics, testing, and ends with specifics of calibrating for use in EPA monitoring.

Part III provides detailed technical information, starting with maintenance, troubleshooting and service with Frequently Asked Questions (FAQs), followed by principles of operation, and a glossary. It also contains a special section dedicated to providing information about electro-static discharge and protecting against its consequences.

The appendices at the end of this manual provide support information such as, version-specific software documentation, lists of spare parts and recommended stocking levels, and schematics.

CONVENTIONS USED

In addition to the safety symbols as presented in the *Important Safety Information* page, this manual provides *special notices* related to the safety and effective use of the analyzer and other pertinent information.

Special Notices appear as follows:

ATTENTION

COULD DAMAGE INSTRUMENT AND VOID WARRANTY
 This special notice provides information to avoid damage to your instrument and possibly invalidate the warranty.

IMPORTANT

IMPACT ON READINGS OR DATA
 Could either affect accuracy of instrument readings or cause loss of data.

Note

Pertinent information associated with the proper care, operation or maintenance of the analyzer or its parts.

This page intentionally left blank..

TABLE OF CONTENTS

Safety Messages	iii
About This Manual	v
PART I GENERAL INFORMATION	17
1. Introduction, Features and Options	19
1.1. Overview	19
1.2. Features	19
1.3. Documentation	20
1.4. Options	20
2. Specifications, Approvals, & Compliance	23
2.1. Specifications	23
2.2. EPA Equivalency Designation	24
2.3. Approvals and Certifications	25
2.3.1. Safety	25
2.3.2. EMC	25
2.3.3. Other Type Certifications	25
3. Getting Started	27
3.1. Unpacking the 9110T Analyzer	27
3.1.1. Ventilation Clearance	28
3.2. Instrument Layout	28
3.2.1. Front Panel	29
3.2.2. Rear Panel	33
3.2.3. Internal Chassis Layout	34
3.3. Connections and Setup	37
3.3.1. Electrical Connections	37
3.3.2. Pneumatic Connections	51
3.4. Startup, Functional Checks, and Initial Calibration	70
3.4.1. Start Up	70
3.4.2. Warning Messages	71
3.4.3. Functional Checks	73
3.4.4. Initial Calibration	73
3.4.4.1. Interferents	74
PART II – OPERATING INSTRUCTIONS	79
4. Overview of Operating Modes	81
4.1. Sample Mode	82
4.1.1. Test Functions	82
4.1.2. Warning Messages	85
4.2. Calibration Mode	86
4.3. Setup Mode	86
4.3.1. Password Security	87
4.3.2. Primary Setup Menu	87
4.3.3. Secondary Setup Menu (SETUP → MORE)	87
5. Setup Menu	89
5.1. SETUP → CFG: Configuration Information	89
5.2. SETUP → ACAL: Automatic Calibration Option	89
5.3. SETUP → DAS: Internal Data Acquisition System	89
5.4. SETUP → RNGE: Analog Output Reporting Range Configuration	90
5.4.1. 9110T Physical Ranges	90
5.4.2. 9110T Analog Output Reporting Ranges	90
5.4.3. SETUP → RNGE → MODE	92
5.5. SETUP → PASS: Password Protection	100
5.6. SETUP → CLK: Setting the Internal Time-of-Day Clock	102
5.6.1. Setting the Time of Day	102
5.6.2. Adjusting the Internal Clock's Speed	103
5.7. SETUP → COMM: Communications Ports	104
5.7.1. ID (Machine Identification)	104
5.7.2. INET (Ethernet)	105
5.7.3. COM1[COM2] (Mode, Baud Rate and Test Port)	105
5.8. SETUP → VARS: Variables Setup and Definition	105
5.9. SETUP → Diag: Diagnostics Functions	108
5.9.1. Signal I/O	110
5.9.2. Analog Output (DIAG AOUT)	111
5.9.3. Analog I/O Configuration (DIAG AIO)	111

5.9.4. Test Chan Output (Selecting a Test Channel Function for Output A4)	126
5.9.5. Optic Test	127
5.9.6. Electrical Test	128
5.9.7. Ozone Gen Override	128
5.9.8. Flow Calibration	128
6. Communications Setup and Operation	129
6.1. Data Terminal / Communication Equipment (DTE DEC)	129
6.2. Communication Modes, Baud Rate and Port Testing	129
6.2.1. Communication Modes	129
6.2.2. Com Port Baud Rate	132
6.2.3. Com Port Testing	132
6.3. RS-232	133
6.4. RS-485 (Option)	134
6.5. Ethernet	134
6.5.1. Configuring Ethernet Communication Manually (Static IP Address)	134
6.5.2. Configuring Ethernet Communication Using Dynamic Host Configuration Protocol (DHCP)	137
6.6. USB Port for Remote Access	141
7. Data Acquisition System (DAS) and APICOM	145
7.1. DAS Structure	146
7.1.1. DAS Channels	146
7.1.2. Viewing DAS Data and Settings	150
7.1.3. Editing DAS Data Channels	151
7.2. Remote DAS Configuration	163
7.2.1. DAS Configuration via APICOM	163
7.2.2. DAS Configuration via Terminal Emulation Programs	165
8. Remote Operation	167
8.1. Computer Mode	167
8.1.1. Remote Control via APICOM	167
8.2. Interactive Mode	167
8.2.1. Remote Control via a Terminal Emulation Program	167
8.3. Remote Access by Modem	170
8.4. Password Security for Serial Remote Communications	173
9. Calibration Procedures	175
9.1. Before Calibration	176
9.1.1. Required Equipment, Supplies, and Expendables	176
9.1.2. Calibration Gases	177
9.1.3. Data Recording Devices	178
9.1.4. NO ₂ Conversion Efficiency (CE)	179
9.2. Manual Calibration Checks and Calibration of the 9110T Analyzer in its Base Configuration	179
9.2.1. Setup for Basic Calibration Checks and Calibration of the 9110T analyzer	179
9.2.2. Performing a Basic Manual Calibration Check	181
9.2.3. Performing a Basic Manual Calibration	181
9.3. Manual Calibration with the Internal Span Gas Generator	184
9.3.1. Performing "Precision" Manual Calibration when Internal Span Gas (IZS) Generator Option is Present	184
9.3.2. Setup for Calibration with the Internal Span Gas Generator	185
9.3.3. CAL On NO ₂ Feature	185
9.3.4. Performing a Manual Calibration Check with the Internal Span Gas Generator	187
9.3.5. Performing a Manual Calibration with the Internal Span Gas Generator	188
9.4. Manual Calibration and Cal Checks with the Valve Options Installed	191
9.4.1. Setup for Calibration Using Valve Options	191
9.4.2. Manual Calibration Checks with Valve Options Installed	192
9.4.3. Manual Calibration Using Valve Options	193
9.5. Automatic Zero/Span Cal/Check (AutoCal)	195
9.5.1. SETUP → ACAL: Programming and AUTO CAL Sequence	198
9.6. Calibration Quality Analysis	201
9.7. Gas Flow Calibration	202
10. EPA Protocol Calibration	203
10.1. 9110T Calibration – General Guidelines	203
10.2. Calibration Equipment, Supplies, and Expendables	204
10.2.1. Spare Parts and Expendable Supplies	204
10.2.2. Calibration Gas and Zero Air Sources	205
10.2.3. Data Recording Device	205
10.2.4. Record Keeping	205
10.3. Calibration Frequency	205
10.4. Level 1 Calibrations versus Level 2 Checks	206

10.5. Gas Phase Titration (GPT).....	207
10.5.1. GPT Principle of Operation.....	207
10.5.2. GPT Calibrator Check Procedure.....	207
10.6. GPT Multipoint Calibration Procedure.....	210
10.6.1. Set Up for GPT Multipoint Calibration of the 9110T.....	211
10.6.2. Zero Calibration.....	212
10.6.3. Span Calibration.....	212
10.7. GPT NO ₂ Check.....	213
10.8. Other Quality Assurance Procedures.....	214
10.8.1. Summary of Quality Assurance Checks.....	214
10.8.2. Short Calibration Checks.....	215
10.8.3. Zero/Span Check Procedures.....	215
10.8.4. Precision Check.....	216
10.9. Certification of Working Standards.....	216
10.10. References.....	217
PART III – Maintenance and Service.....	219
11. Instrument Maintenance.....	221
11.1. Maintenance Schedule.....	221
11.2. Predictive Diagnostics.....	223
11.3. Maintenance Procedures.....	223
11.3.1. Replacing the Sample Particulate Filter.....	224
11.3.2. Changing the O ₃ Dryer Particulate Filter.....	225
11.3.3. Changing the Ozone Cleanser Chemical.....	226
11.3.4. Maintaining the External Sample Pump (Pump Pack).....	229
11.3.5. Changing the Pump DFU Filter.....	229
11.3.6. Changing the Internal Span Gas Generator Permeation Tube.....	231
11.3.7. Changing the External Zero Air Scrubber (OPT 86C).....	231
11.3.8. Changing the NO ₂ Converter.....	234
11.3.9. Cleaning the Reaction Cell.....	236
11.3.10. Replacing Critical Flow Orifices.....	238
11.3.11. Checking for Light Leaks.....	239
11.3.12. Checking for Pneumatic Leaks.....	240
12. Troubleshooting & Service.....	243
12.1. General Troubleshooting.....	243
12.1.1. Fault Diagnosis with WARNING Messages.....	244
12.1.2. Fault Diagnosis With Test Functions.....	248
12.1.3. DIAG → SIGNAL I/O: Using the Diagnostic Signal I/O Function.....	249
12.2. Using the Analog Output Test Channel.....	251
12.3. Using the Internal Electronic Status LEDs.....	252
12.3.1. CPU Status Indicator.....	252
12.3.2. Relay PCA Status LEDs.....	252
12.4. Gas Flow Problems.....	254
12.4.1. Zero or Low Flow Problems.....	254
12.5. Calibration Problems.....	258
12.5.1. Negative Concentrations.....	258
12.5.2. No Response.....	259
12.5.3. Unstable Zero and Span.....	259
12.5.4. Inability to Span - No SPAN Button (CALS).....	260
12.5.5. Inability to Zero - No ZERO Button (CALZ).....	260
12.5.6. Non-Linear Response.....	261
12.5.7. Discrepancy Between Analog Output and Display.....	262
12.5.8. Discrepancy Between NO and NOX slopes.....	262
12.6. Other Performance Problems.....	263
12.6.1. Excessive Noise.....	263
12.6.2. Slow Response.....	263
12.6.3. Auto Zero Warnings.....	264
12.7. Subsystem Checkout.....	265
12.7.1. AC Main Power.....	265
12.7.2. DC Power Supply.....	265
12.7.3. I ² C Bus.....	267
12.7.4. LCD/Display Module.....	267
12.7.5. Relay PCA.....	267
12.7.6. Motherboard.....	267
12.7.7. Pressure / Flow Sensor Assembly.....	271
12.7.8. CPU.....	272

12.7.9. RS-232 Communications	272
12.7.10. NO ₂ → NO Converter	273
12.7.11. Simplified GPT Calibration	278
12.7.12. Photomultiplier Tube (PMT) Sensor Module	282
12.7.13. PMT Preamplifier Board	284
12.7.14. PMT Temperature Control PCA	285
12.7.15. O ₃ Generator	286
12.7.16. Internal Span Gas Generator and Valve Options	287
12.7.17. Temperature Sensor	288
12.8. Service Procedures	290
12.8.1. Disk-On-Module Replacement Procedure	290
12.8.2. O ₃ Generator Replacement	291
12.8.3. Sample and Ozone (Perma Pure [®]) Dryer Replacement	291
12.8.4. PMT Sensor Hardware Calibration	292
12.8.5. Replacing the PMT, HVPS or TEC	294
12.8.6. Removing / Replacing the Relay PCA from the Instrument	297
12.9. Frequently Asked Questions	298
12.10. Technical Assistance	300
13. Principles of Operation.....	301
13.1. Measurement Principle.....	301
13.1.1. Chemiluminescence Creation in the 9110T Reaction Cell	301
13.1.2. Chemiluminescence Detection in the 9110T Reaction Cell	302
13.1.3. NO _x and NO ₂ Determination	303
13.1.4. Auto Zero	304
13.1.5. Measurement Interferences	305
13.2. Pneumatic Operation.....	308
13.2.1. Sample Gas Flow	308
13.2.2. Flow Rate Control - Critical Flow Orifices	312
13.2.3. Ozone Gas Generation and Air Flow	314
13.2.4. Pneumatic Sensors.....	317
13.3. Electronic Operation.....	320
13.3.1. Overview.....	320
13.3.2. CPU	321
13.3.3. Motherboard	322
13.3.4. Relay PCA	327
13.4. Sensor Module, Reaction Cell	333
13.5. Photo Multiplier Tube (PMT).....	334
13.5.1. PMT Preamplifier	335
13.5.2. PMT Cooling System	337
13.6. Pneumatic Sensor Board.....	338
13.7. Power Supply/Circuit Breaker.....	339
13.7.1. AC Power Configuration	340
13.8. Front Panel Touchscreen/Display Interface.....	345
13.8.1. LVDS Transmitter Board.....	346
13.8.2. Front Panel Touchscreen/Display Interface PCA	346
13.9. Software Operation	346
13.9.1. Adaptive Filter.....	347
13.9.2. Temperature/Pressure Compensation (TPC)	347
13.9.3. Calibration - Slope and Offset.....	347
14. A Primer on Electro-Static Discharge	349
14.1. How Static Charges are Created	349
14.2. How Electro-Static Charges Cause Damage.....	350
14.3. Common Myths About ESD Damage	351
14.4. Basic Principles of Static Control.....	351
14.4.1. General Rules.....	351
14.5. Basic anti-ESD Procedures for Analyzer Repair and Maintenance	353
14.5.1. Working at the Instrument Rack	353
14.5.2. Working at an Anti-ESD Work Bench	353
14.5.3. Transferring Components Between Rack and Bench	354
14.5.4. Opening Shipments from TAI Customer Service	354
14.5.5. Packing Components for Return to TAI Customer Service.....	355
Glossary	357

APPENDIX A - VERSION SPECIFIC SOFTWARE DOCUMENTATION

APPENDIX B - SPARE PARTS

APPENDIX C - REPAIR QUESTIONNAIRE
APPENDIX D - ELECTRONIC SCHEMATICS

FIGURES

Figure 3-1:	Front Panel Layout.....	29
Figure 3-2:	Display Screen and Touch Control.....	30
Figure 3-3:	Display/Touch Control Screen Mapped to Menu Charts.....	32
Figure 3-4:	Rear Panel Layout – Base Unit.....	33
Figure 3-5:	Internal Layout – Top View with IZS Option.....	35
Figure 3-6:	Internal Layout - Top View Showing Other Options.....	36
Figure 3-7:	Analog In Connector.....	38
Figure 3-8:	Analog Output Connector.....	39
Figure 3-9:	Current Loop Option Installed on the Motherboard.....	40
Figure 3-10:	Status Output Connector.....	41
Figure 3-11:	Energizing the 9110T Control Inputs.....	42
Figure 3-12:	Concentration Alarm Relay.....	43
Figure 3-13:	Rear Panel Connector Pin-Outs for RS-232 Mode.....	46
Figure 3-14:	Default Pin Assignments for CPU COMM Port Connector (RS-232).....	47
Figure 3-15:	Jumper and Cables for Multidrop Mode.....	49
Figure 3-16:	RS-232-Multidrop PCA Host/Analyzer Interconnect Diagram.....	50
Figure 3-17:	Gas Line Connections from Calibrator – Basic 9110T Configuration.....	55
Figure 3-18:	Gas Line Connections from Bottled Span Gas – Basic 9110T Configuration.....	56
Figure 3-19:	Pneumatics, Basic Configuration.....	58
Figure 3-20:	Rear Panel Layout with Z/S Valve Options (OPT 50A).....	59
Figure 3-21:	Gas Line Connections for 9110T with Z/S Valves Option (OPT 50A).....	59
Figure 3-22:	Pneumatics with Zero/Span Valves OPT 50A.....	61
Figure 3-23:	Rear Panel Layout with Ambient Zero/Pressurized Span Valves OPT 50B.....	62
Figure 3-24:	Gas Line Connection w/Ambient Zero/Pressurized Span Valves (OPT 50B).....	63
Figure 3-25:	Pneumatics with Ambient Zero/Pressurized Span Valves (OPT 50B).....	64
Figure 3-26:	Rear Panel Layout with Internal Span Source (IZS) OPT 50G.....	66
Figure 3-27:	Pneumatics with the Internal Span Gas Generator (OPT 50G).....	67
Figure 3-28:	Pneumatics for Sample Conditioner OPT 86A.....	68
Figure 3-29:	Pneumatics for External Zero Air Scrubber (OPT 86C) for Z/S Valves.....	69
Figure 4-1:	Front Panel Display.....	81
Figure 4-2:	Viewing 9110T Test Functions.....	84
Figure 5-1:	Analog Output Connector Pin Out.....	91
Figure 5-2:	SETUP – COMM Menu.....	104
Figure 5-3:	COMM– Machine ID.....	104
Figure 5-4:	Accessing the DIAG Submenus.....	109
Figure 5-5:	Accessing the Analog I/O Configuration Submenus.....	112
Figure 5-6:	Setup for Checking / Calibrating DCV Analog Output Signal Levels.....	117
Figure 5-7:	Setup for Checking / Calibration Current Output Signal Levels Using an Ammeter.....	119
Figure 5-8:	Alternative Setup Using 250Ω Resistor for Checking Current Output Signal Levels.....	121
Figure 6-1:	COMM – Communication Modes Setup.....	131
Figure 6-2:	COMM – COMM Port Baud Rate.....	132
Figure 6-3:	COMM – COM1 Test Port.....	133
Figure 6-4:	COMM - LAN /Internet Manual Configuration.....	136
Figure 6-5:	COMM – LAN / Internet Automatic Configuration (DHCP).....	139
Figure 6-6:	COMM – Change Hostname.....	140
Figure 7-1:	Default DAS Channels Setup.....	149
Figure 7-2:	APICOM Remote Control Program Interface.....	163
Figure 7-3:	Sample APICOM User Interface for Configuring the DAS.....	164
Figure 7-4:	DAS Configuration Through a Terminal Emulation Program.....	165
Figure 8-1:	Remote Access by Modem.....	171
Figure 9-1:	Set up for Manual Calibrations/Checks of 9110T's in Base Configuration w/ a Gas Dilution Calibrator.....	180
Figure 9-2:	Set up for Manual Calibrations/Checks of 9110T's in Base Configuration w/ Bottled Gas.....	180
Figure 9-3:	Pneumatic Connections for 9110T Precision Calibration when IZS Generator Present.....	184
Figure 9-4:	Pneumatic Connections for Manual Calibration/Checks with the Internal Span Gas Generator.....	185

Figure 10-1:	GPT Calibration System	211
Figure 11-1	Replacing the Particulate Filter	224
Figure 11-2:	Particle Filter on O ₃ Supply Air Dryer	225
Figure 11-3:	Ozone Cleanser Assembly	227
Figure 11-4:	Zero Air Scrubber Assembly	233
Figure 11-5:	NO ₂ Converter Assembly	235
Figure 11-6:	Reaction Cell Assembly	237
Figure 11-7:	Critical Flow Orifice Assembly	238
Figure 12-1:	Example of Signal I/O Function	250
Figure 12-2:	CPU Status Indicator	252
Figure 12-3:	Relay PCA Status LEDES Used for Troubleshooting	253
Figure 12-4:	Location of DC Power Test Points on Relay PCA	266
Figure 12-5:	Typical Set Up of Status Output Test	269
Figure 12-6:	Pressure / Flow Sensor Assembly	271
Figure 12-7:	Setup for determining NO ₂ → NO Efficiency – 9110T Base Configuration	275
Figure 12-8:	Pre-Amplifier Board Layout.....	293
Figure 12-9:	9110T Sensor Assembly	295
Figure 12-10:	Relay PCA with AC Relay Retainer In Place	297
Figure 12-11:	Relay PCA Mounting Screw Locations	298
Figure 13-1:	Reaction Cell with PMT Tube and Optical Filter	303
Figure 13-2:	9110T Sensitivity Spectrum	303
Figure 13-3:	NO ₂ → NO Conversion	304
Figure 13-4:	Pneumatic Flow During the Auto Zero Cycle	305
Figure 13-5:	Internal Gas Flow for Basic 9110T with External Pump	309
Figure 13-6:	Basic Internal Gas Flow for Basic 9110T with Internal Pump	310
Figure 13-7:	Vacuum Manifold, Standard Configuration	311
Figure 13-8:	Flow Control Assembly & Critical Flow Orifice	312
Figure 13-9:	Location of Flow Control Assemblies & Critical Flow Orifices	313
Figure 13-10:	Ozone Generator Principle	315
Figure 13-11:	Semi-Permeable Membrane Drying Process	316
Figure 13-12:	9110T Perma Pure [®] Dryer	316
Figure 13-13:	9110T Electronic Block Diagram	320
Figure 13-14:	CPU Board	322
Figure 13-15:	Relay PCA Layout (P/N 045230100)	327
Figure 13-16:	Relay PCA P/N 045230100 with AC Relay Retainer in Place	328
Figure 13-17:	Status LED Locations – Relay PCA	330
Figure 13-18:	Heater Control Loop Block Diagram	331
Figure 13-19:	Thermocouple Configuration Jumper (JP5) Pin-Outs	333
Figure 13-20:	9110T Sensor Module Assembly	334
Figure 13-21:	Basic PMT Design	335
Figure 13-22:	PMT Preamp Block Diagram	336
Figure 13-23:	Typical Thermo-Electric Cooler	337
Figure 13-24:	PMT Cooling System Block Diagram	338
Figure 13-25:	Power Distribution Block Diagram	340
Figure 13-26:	Location of AC power Configuration Jumpers	341
Figure 13-27:	Pump AC Power Jumpers (JP7)	342
Figure 13-28:	Typical Set Up of AC Heater Jumper Set (JP2)	343
Figure 13-29:	Typical Jumper Set (JP2) Set Up of Heaters	344
Figure 13-30:	Front Panel and Display Interface Block Diagram	345
Figure 13-31:	Basic Software Operation	346
Figure 14-1:	Triboelectric Charging	349
Figure 14-2:	Basic anti-ESD Workbench	352

TABLES

Table 1-1:	Analyzer Options.....	20
Table 2-2:	Software Settings for EPA Equivalence.....	24
Table 3-1:	Ventilation Clearance.....	28
Table 3-2:	Display Screen and Touch Control Description.....	31
Table 3-3:	Rear Panel Description.....	34
Table 3-4:	Analog Input Pin Assignments.....	38
Table 3-5:	Analog Output Pin Assignments.....	39
Table 3-6:	Status Output Pin Assignments.....	41
Table 3-7:	Control Input Pin Assignments.....	42
Table 3-8:	NIST-SRM's Available for Traceability of NO _x Calibration Gases.....	53
Table 3-9:	Zero/Span Valves Operating States OPT 50A.....	61
Table 3-10:	Valve Operating States OPT 50B installed.....	65
Table 3-11:	Internal Span Gas Generator Valve Operating States OPT 50G.....	67
Table 3-12:	Possible Warning Messages at Start-Up.....	72
Table 4-1:	Analyzer Operating Modes.....	82
Table 4-2:	Test Functions Defined.....	82
Table 4-3:	Warning Messages Defined.....	85
Table 4-4:	Primary Setup Mode Features and Functions.....	87
Table 4-5:	Secondary Setup Mode Features and Functions.....	87
Table 5-1:	IND Mode Analog Output Assignments.....	93
Table 5-2:	Password Levels.....	100
Table 5-3:	Variable Names (VARS).....	105
Table 5-4:	Diagnostic Mode (DIAG) Functions.....	108
Table 5-5:	DIAG - Analog I/O Functions.....	111
Table 5-6:	Analog Output Voltage Range Min/Max.....	113
Table 5-7:	Voltage Tolerances for the TEST CHANNEL Calibration.....	117
Table 5-8:	Current Loop Output Check.....	121
Table 5-9:	Test Channels Functions available on the 9110T's Analog Output.....	126
Table 6-1:	COMM Port Communication Modes.....	129
Table 6-2:	Ethernet Status Indicators.....	134
Table 7-1:	Front Panel LED Status Indicators for DAS.....	145
Table 7-2:	DAS Data Channel Properties.....	146
Table 7-3:	DAS Data Parameter Functions.....	154
Table 8-1:	Terminal Mode Software Commands.....	168
Table 8-2:	Teledyne API's Serial I/O Command Types.....	168
Table 9-1:	IZS Option Valve States with CAL_ON_NO ₂ Turned ON.....	185
Table 9-2:	AUTOCAL Modes.....	195
Table 9-3:	AutoCal Attribute Setup Parameters.....	196
Table 9-4:	Example AutoCal Sequence.....	197
Table 9-5:	Calibration Data Quality Evaluation.....	201
Table 10-1:	Activity Matrix for EPA Calibration Equipment and Supplies.....	204
Table 10-2:	Definition of Level 1 and Level 2 Zero and Span Checks.....	206
Table 10-3:	Activity Matrix for Data Quality.....	215
Table 11-1:	9110T Maintenance Schedule.....	222
Table 11-2:	Predictive Uses for Test Functions.....	223
Table 12-1:	Front Panel Warning Messages.....	246
Table 12-2:	Test Functions - Indicated Failures.....	248
Table 12-3:	Test Channel Outputs as Diagnostic Tools.....	251
Table 12-4:	Relay PCA Watchdog LED Failure Indications.....	252
Table 12-5:	Relay PCA Status LED Failure Indications.....	253
Table 12-6:	DC Power Test Point and Wiring Color Codes.....	266
Table 12-7:	DC Power Supply Acceptable Levels.....	266
Table 12-8:	Relay PCA Control Devices.....	267
Table 12-9:	Analog Output Test Function - Nominal Values Voltage Outputs.....	268
Table 12-10:	Status Outputs Check.....	270
Table 12-11:	9110T Control Input Pin Assignments and Corresponding Signal I/O Functions.....	270

Table 13-1:	List of Interferents	307
Table 13-2:	9110T Valve Cycle Phases.....	311
Table 13-3:	9110T Gas Flow Rates	313
Table 13-4:	Relay PCA Status LED's	329
Table 13-5:	Thermocouple Configuration Jumper (JP5) Pin-Outs.....	332
Table 13-6:	AC Power Configuration for Internal Pumps (JP7)	342
Table 13-7:	Power Configuration for Standard AC Heaters (JP2).....	343
Table 13-8:	Power Configuration for Optional Heaters (JP6)	344
Table 14-1:	Static Generation Voltages for Typical Activities	349
Table 14-2:	Sensitivity of Electronic Devices to Damage by ESD	350

This page intentionally left blank.

PART I
GENERAL INFORMATION

This page intentionally left blank.

1. INTRODUCTION, FEATURES AND OPTIONS

1.1. OVERVIEW

The Model 9110T Nitrogen Oxides Analyzer uses chemiluminescence detection, coupled with state-of-the-art microprocessor technology to provide the sensitivity, stability and ease of use needed for ambient or dilution CEM monitoring requirements of nitric oxide (NO), nitrogen dioxide (NO₂) and the total nitrogen oxides (NO_x). The instrument:

- Calculates the amount of NO present by measuring the amount of chemiluminescence given off when the sample gas is exposed to ozone (O₃).
- Uses a catalytic-reactive converter to convert any NO₂ in the sample gas to NO, which is then measured as above (including the original NO in the sample gas) and reported as NO_x.

Since the density of the sample gas effects the brightness of the chemiluminescence reaction, the 9110T software compensates for temperature and pressure changes.

Stability is further enhanced by an Auto-Zero feature which periodically redirects the gas flow through the analyzer so that no chemiluminescence reaction is present in the sample chamber. The analyzer measures this “dark” condition and uses the results as an offset, which is subtracted from the sensor readings recorded while the instrument is measuring NO and NO_x. The result gives a sensitive, accurate, and dependable performance under the harshest operating conditions.

The 9110T analyzer’s multi-tasking software gives the ability to track and report a large number of operational parameters in real time. These readings are compared to diagnostic limits kept in the analyzers memory and should any fall outside of those limits the analyzer issues automatic warnings.

Built-in data acquisition capability, using the analyzer's internal memory, allows the logging of multiple parameters including averaged or instantaneous concentration values, calibration data, and operating parameters such as pressure and flow rate. Stored data are easily retrieved through the rear panel serial or Ethernet ports via our APICOM software or from the front panel, allowing operators to perform predictive diagnostics and enhanced data analysis by tracking parameter trends. Multiple averaging periods of one minute to 365 days are available for over a period of one year.

1.2. FEATURES

Some of the other exceptional features of your 9110T Nitrogen Oxides Analyzer are:

- Ranges, 0-50 ppb to 0-20 ppm, user selectable
- Independent ranges and auto ranging
- Large, vivid, and durable graphics display with touch screen interface
- Microprocessor controlled for versatility
- Multi-tasking software to allow viewing test variables while operating
- Continuous self checking with alarms
- Permeation dryer on ozone generator
- Bi-directional RS-232, optional USB and RS-485, and 10/100Base-T Ethernet ports for remote operation
- Front panel USB ports for peripheral devices and firmware upgrades
- Digital status outputs to provide instrument operating condition
- Adaptive signal filtering to optimize response time

- Temperature and pressure compensation
- Converter efficiency correction software
- Catalytic ozone destruct
- Comprehensive internal data logging with programmable averaging periods
- Ability to log virtually any operating parameter
- 8 analog inputs (optional)
- Internal zero and span check (optional)

1.3. DOCUMENTATION

In addition to this operation manual, two other manuals are available for download from Teledyne's website at <http://www.teledyne-api.com/manuals/>, to support the operation of the instrument:

- APICOM Software Manual, part number 03945
- DAS Manual, part number 02837

1.4. OPTIONS

The options available for your analyzer are present in with name, option number, a description and/or comments, and if applicable, cross-references to technical details in this manual, such as setup and calibration. To order these options or to learn more about them, please contact Teledyne Sales Department at:

TOLL-FREE: 888-789-8168
 PHONE: +1 626-934-1500
 FAX: +1 626-961-2538
 EMAIL: ask_tai@teledyne.com
 WEBSITE: <http://www.teledyne-ai.com/>

Table 1-1. Analyzer Options

Option	Option Number	Description/Notes	Reference
Pumps		Pumps meet all typical AC power supply standards while exhibiting same pneumatic performance.	
	11A	Ship without pump	N/A
	11B	Pumpless Pump Pack	N/A
	12A	Internal Pump 115V @ 60 Hz	N/A
	12B	Internal Pump 220V @ 60 Hz	N/A
	12C	Internal Pump 220V @ 50 Hz	N/A
Rack Mount Kits		Options for mounting the analyzer in standard 19" racks	
	20A	Rack mount brackets with 26 in. (660 mm) chassis slides	N/A
	20B	Rack mount brackets with 24 in. (610 mm) chassis slides	N/A
	21	Rack mount brackets only (compatible with carrying strap, Option 29)	N/A
	23	Rack mount for external pump pack (no slides)	N/A

Option	Option Number	Description/Notes	Reference
Carrying Strap/Handle		Side-mounted strap for hand-carrying analyzer	
	29	Extends from “flat” position to accommodate hand for carrying. Recesses to 9mm (3/8”) dimension for storage. Can be used with rack mount brackets, Option 21. Cannot be used with rack mount slides.	N/A
	CAUTION – GENERAL SAFETY HAZARD		
	THE 9110T ANALYZER WEIGHS ABOUT 18 KG (40 POUNDS). TO AVOID PERSONAL INJURY WE RECOMMEND THAT TWO PERSONS LIFT AND CARRY THE ANALYZER. DISCONNECT ALL CABLES AND TUBING FROM THE ANALYZER BEFORE MOVING IT.		
Analog Input and USB port		Used for connecting external voltage signals from other instrumentation (such as meteorological instruments).	
	64B	Also can be used for logging these signals in the analyzer’s internal DAS	Sections 3.3.1.2, and 7
Current Loop Analog Outputs		Adds isolated, voltage-to-current conversion circuitry to the analyzer’s analog outputs.	
	41	Can be configured for any output range between 0 and 20 mA. May be ordered separately for any of the analog outputs. Can be installed at the factory or retrofitted in the field.	Sections 3.3.1.4 and 5.9.3.7
Parts Kits		Spare parts and expendables	
	42A	Expendables Kit includes a recommended set of expendables for one year of operation of this instrument including replacement sample particulate filters.	Appendix B
	43	Expendables Kit with IZS includes the items needed to refurbish the zero air scrubber.	Appendix B
	45	Spare Parts Kit includes spares parts for one unit.	Appendix B
Calibration Valves		Used to control the flow of calibration gases generated from external sources, rather than manually switching the rear panel pneumatic connections.	
	50A	AMBIENT ZERO AND AMBIENT SPAN VALVES Zero Air and Span Gas input supplied at ambient pressure. Gases controlled by 2 internal valves; SAMPLE/CAL & ZERO/SPAN.	Section 3.3.2.3
	50B	AMBIENT ZERO AND PRESSURIZED SPAN VALVES Span Gas input from external, pressurized source; Span Gas flow rate maintained at 1 ATM by critical flow orifice & vented through Vent port. Shutoff valve stops flow of Span Gas when in sample mode to preserve pressurized gas source. Zero Air created via 2-stage scrubber & dry filter unit (DFU). Gases controlled by 2 internal valves; SAMPLE/CAL & ZERO/SPAN.	Section 3.3.2.4
	50G	ZERO SCRUBBER AND INTERNAL SPAN SOURCE (IZS) Span Gas generated from internal NO ₂ permeation tube Zero Air created by 2-stage scrubber & DFU. Gases controlled by 2 internal valves: Sample/Cal & Zero/Span.	Sections 3.3.2.5 and 3.3.2.6
NO₂ Permeation Tubes		Replacement tubes; identical size/shape; different permeation rates.	
		Permeation Rate (± 25%)	Approximate NO ₂ Concentration @ 50°C
	52B	421 ng/min	300ppb – 500 ppb ± 25%
	52G	842 ng/min	0600 – 1000 ppb ± 25%
		Each tube comes with a calibration certificate, traceable to a NIST standard, specifying its actual effusion rate of that tube to within ± 5% @ 0.56 liters per	
			Section 3.3.2.5

Option	Option Number	Description/Notes	Reference	
minute, calibration performed at a tube temperature of 50°C.				
Communication Cables		For remote serial, network and Internet communication with the analyzer.		
		Type	Description	
	60A	RS-232	Shielded, straight-through DB-9F to DB-25M cable, about 1.8 m long. Used to interface with older computers or code activated switches with DB-25 serial connectors.	Section 3.3.1.8
	60B	RS-232	Shielded, straight-through DB-9F to DB-9F cable of about 1.8 m length.	Section 3.3.1.8
	60C	Ethernet	Patch cable, 2 meters long, used for Internet and LAN communications.	Section 3.3.1.8
	60D	USB	Cable for direct connection between instrument (rear panel USB port) and personal computer.	Section 3.3.1.8
USB Port		For remote connection		
	64A	For connection to personal computer. (Separate option only when Option 64B, <i>Analog Input and USB Com Port</i> not elected).		Sections 3.3.1.8 and 6.6
Concentration Alarm Relays		Issues warning when gas concentration exceeds limits set by user.		
	61	Four (4) “dry contact” relays on the rear panel of the instrument. This relay option is different from and in addition to the “Contact Closures” that come standard on all TAPI instruments.		Section 3.3.1.7
RS-232 Multidrop		Enables communications between host computer and up to eight analyzers.		
	62	Multidrop card seated on the analyzer’s CPU card. Each instrument in the multidrop network requires this card and a communications cable (Option 60B).		Section 3.3.1.8
Other Gas Options		Second gas sensor and gas conditioners		
	65A	Oxygen (O ₂) Sensor	Figure 3-6	
	86A	Ammonia removal sample conditioner (required for EN Certification)	3.3.2.6, 3.4.4.1	
	86C	External zero air scrubber	Figure 3-29, Sections 3.3.2.6, 9.1.2.1, 11.3.7, and 11.3.7.1, Table 11-1	
Special Features		Built in features, software activated		
	N/A	Maintenance Mode Switch , located inside the instrument, places the analyzer in maintenance mode where it can continue sampling, yet ignore calibration, diagnostic, and reset instrument commands. This feature is of particular use for instruments connected to Multidrop networks. Call Customer Service for activation.		N/A
	N/A	Second Language Switch activates an alternate set of display messages in a language other than the instrument’s default language. Call Customer Service for a specially programmed Disk on Module containing the second language.		N/A
	N/A	Dilution Ratio Option allows the user to compensate for diluted sample gas, such as in continuous emission monitoring (CEM) where the quality of gas in a smoke stack is being tested and the sampling method used to remove the gas from the stack dilutes the gas. Call Customer Service for activation.		Section 5.4.3.5

2. SPECIFICATIONS, APPROVALS, & COMPLIANCE

This section presents specifications for the 9110T, Agency approvals, EPA designation, and CE mark and safety compliance..

2.1. SPECIFICATIONS

Table 2-1 presents the instrument's parameters and the specifications that each meets.

Table 2-1: 9110T Basic Unit Specifications

Parameter	Specification
Min/Max Range (Physical Analog Output)	Min: 0-50 ppb Full Scale Max: 0-20,000 ppb Full Scale (selectable, independent NO, NO ₂ , NO _x ranges and auto ranges supported)
Measurement Units	ppb, ppm, µg/m ³ , mg/m ³ (selectable)
Zero Noise ¹	< 0.2 ppb (RMS)
Span Noise ¹	< 0.5% of reading (RMS) above 50 ppb or 0.2 ppb, whichever is greater
Lower Detectable Limit ²	0.4 ppb
Zero Drift	< 0.5 ppb (at constant temperature and voltage) /24 hours
Span Drift	< 0.5% of Full Scale (at constant temperature and voltage) /24 hours
Lag Time ¹	20 seconds
Rise/Fall Time ¹	<60 seconds to 95%
Linearity	1% of full scale / 24 hours
Precision	0.5% of reading above 50 ppb
Sample Flow Rate	500 cm ³ /min ± 10%
AC Power	100-120 V, 60 Hz (3.0 A); 220-240 V, 50 Hz (2.5 A)
Power, Ext Pump	100 V, 50/60 Hz (3.25 A); 115 V, 60 Hz (3.0 A); 220-240 V, 50/60 Hz (2.5 A)
Analog Output Ranges	10V, 5V, 1V, 0.1V (selectable) All Ranges with 5% Under/Over Range
Analog Output Resolution	1 part in 4096 of selected full-scale voltage
Recorder Offset	± 10%
Standard I/O	1 Ethernet: 10/100Base-T 2 RS-232 (300 – 115,200 baud) 2 USB device ports 8 opto-isolated digital status outputs (7 defined, 1 spare) 6 opto-isolated digital control inputs (4 defined, 2 spar) 4 analog outputs
Optional I/O	1 USB com port 1 RS485 8 analog inputs (0-10V, 12-bit) 4 digital alarm outputs Multidrop RS232 3 4-20mA current outputs
Dimensions H x W x D	7" x 17" x 23.5" (178mm x 432 mm x 597 mm)
Weight	Analyzer: 40 lbs (18 kg)

Parameter	Specification
	External Pump Pack: 15 lbs (7 kg)
Operating Temperature Range	5 - 40 °C (with EPA equivalency)
Humidity Range	0-95% RH non-condensing
Environmental Conditions	Installation Category (Over voltage Category) II Pollution Degree 2
¹ As defined by the US EPA. ² Defined as twice the zero noise level by the US EPA.	

2.2. EPA EQUIVALENCY DESIGNATION

TAI’s 9110T nitrogen oxides analyzer is designated as a reference method (Number RFNA-1104-099) for NO₂ measurement, as defined in 40 CFR Part 53, when operated under the following conditions:

- Range: Any full-scale range between 0-0.05 and 0-1.0 ppm (parts per million).
- Ambient temperature range of 5 to 40°C.
- With 1-micron PTFE filter element installed in the internal filter assembly.
- Equipped with ozone supply air filter
- Gas flow supplied by External vacuum pump capable of 10 in-Hg-A at 2 standard liters per minute (slpm) or better.
- Software Settings, see Table 2-2:

Table 2-2: Software Settings for EPA Equivalence

Parameter	Setting
Dynamic Zero	OFF or ON
Dynamic Span	OFF
CAL-on-NO ₂	OFF
Dilution Factor	1.0 or OFF
Temp/Pres compensation	ON
AutoCal	ON or OFF
Independent range	ON or OFF
Auto range	ON or OFF

Under the designation, the Analyzer may be operated with or without the following options:

- Rack mount with or without slides.
- Rack mount for external pump.
- 4-20mA isolated analog outputs.
- Zero/Span Valves option.
- Internal Zero/Span (IZS) option with:
 - NO₂ permeation tube - 0.4 ppm at 0.7 liter per minute; certified/uncertified.
 - NO₂ permeation tube - 0.8 ppm at 0.7 liter per minute; certified/uncertified.

Note

Under the designation, the IZS option cannot be used as the source of calibration.

2.3. APPROVALS AND CERTIFICATIONS

The TAI Model 9110T analyzer was tested and certified for Safety and Electromagnetic Compatibility (EMC). This section presents the compliance statements for those requirements and directives.

2.3.1. SAFETY

IEC 61010-1:2001, Safety requirements for electrical equipment for measurement, control, and laboratory use.

CE: 2006/95/EC, Low-Voltage Directive

North American:

cNEMKO (Canada): CAN/CSA-C22.2 No. 61010-1-04
NEMKO-CCL (US): UL No. 61010-1 (2nd Edition)

2.3.2. EMC

EN 61326-1 (IEC 61326-1), Class A Emissions/Industrial Immunity

EN 55011 (CISPR 11), Group 1, Class A Emissions

FCC 47 CFR Part 15B, Class A Emissions

CE: 2004/108/EC, Electromagnetic Compatibility Directive

2.3.3. OTHER TYPE CERTIFICATIONS

MCERTS: Sira MC 050068/05

For additional certifications, please contact Customer Service:

Toll-free Phone: 800-324-5190

Phone: 858-657-9800

Fax: 858-657-9816

Email: api-customerservice@teledyne.com

This page intentionally left blank.

3. GETTING STARTED

This section addresses the procedures for unpacking the instrument and inspecting for damage, presents clearance specifications for proper ventilation, introduces the instrument layout, then presents the procedures for getting started: making electrical and pneumatic connections, and conducting an initial calibration check.

3.1. UNPACKING THE 9110T ANALYZER



CAUTION
GENERAL SAFETY HAZARD

To avoid personal injury, always use two persons to lift and carry the 9110T.

ATTENTION

COULD DAMAGE INSTRUMENT AND VOID WARRANTY

Printed Circuit Assemblies (PCAs) are sensitive to electro-static discharges too small to be felt by the human nervous system. Failure to use ESD protection when working with electronic assemblies will void the instrument warranty. Refer to Section 14 for more information on preventing ESD damage.



CAUTION!

Do not operate this instrument until you've removed dust plugs from SAMPLE and EXHAUST ports on the rear panel.

Note

TAI recommends that you store shipping containers/materials for future use if/when the instrument should be returned to the factory for repair and/or calibration service. See Warranty section in this manual and shipping procedures on our Website at <http://www.teledyne-api.com> under Customer Support > Return Authorization.

Verify that there is no apparent external shipping damage. If damage has occurred, please advise the shipper first, then TAI.

Included with your analyzer is a printed record of the final performance characterization performed on your instrument at the factory. This record, titled Final Test and Validation Data Sheet (P/N 04490) is an important quality assurance and calibration record for this instrument. It should be placed in the quality records file for this instrument.

With no power to the unit, carefully removed the top cover of the analyzer and check for internal shipping damage by carrying out the following steps:

1. Carefully remove the top cover of the analyzer and check for internal shipping damage.
2. Remove the setscrew located in the top, center of the Front panel.
3. Slide the cover backwards until it clears the analyzer's front bezel.
4. Lift the cover straight up.
5. Inspect the interior of the instrument to ensure all circuit boards and other components are in good shape and properly seated.
6. Check the connectors of the various internal wiring harnesses and pneumatic hoses to ensure they are firmly and properly seated.
7. Verify that all of the optional hardware ordered with the unit has been installed. These are listed on the paperwork accompanying the analyzer.



WARNING – ELECTRICAL SHOCK HAZARD

Never disconnect PCAs, wiring harnesses or electronic subassemblies while under power.

3.1.1. VENTILATION CLEARANCE

Whether the analyzer is set up on a bench or installed into an instrument rack, be sure to leave sufficient ventilation clearance.

Table 3-1: Ventilation Clearance

AREA	MINIMUM REQUIRED CLEARANCE
Back of the instrument	10 cm / 4 in
Sides of the instrument	2.5 cm / 1 in
Above and below the instrument	2.5 cm / 1 in

Various rack mount kits are available for this analyzer. Refer to Section 1.4 of this manual for more information.

3.2. INSTRUMENT LAYOUT

Instrument layout shows front panel and display, rear panel connectors, and internal chassis layout.

3.2.1. FRONT PANEL

Figure 3-1 shows the analyzer's front panel layout, followed by a close-up of the display screen in Figure 3-2, which is described in Table 3-2. The two USB ports on the front panel are provided for the connection of peripheral devices:

- plug-in mouse (not included) to be used as an alternative to the touchscreen interface
- thumb drive (not included) to download updates to instruction software (contact TAPI Customer Service for information).

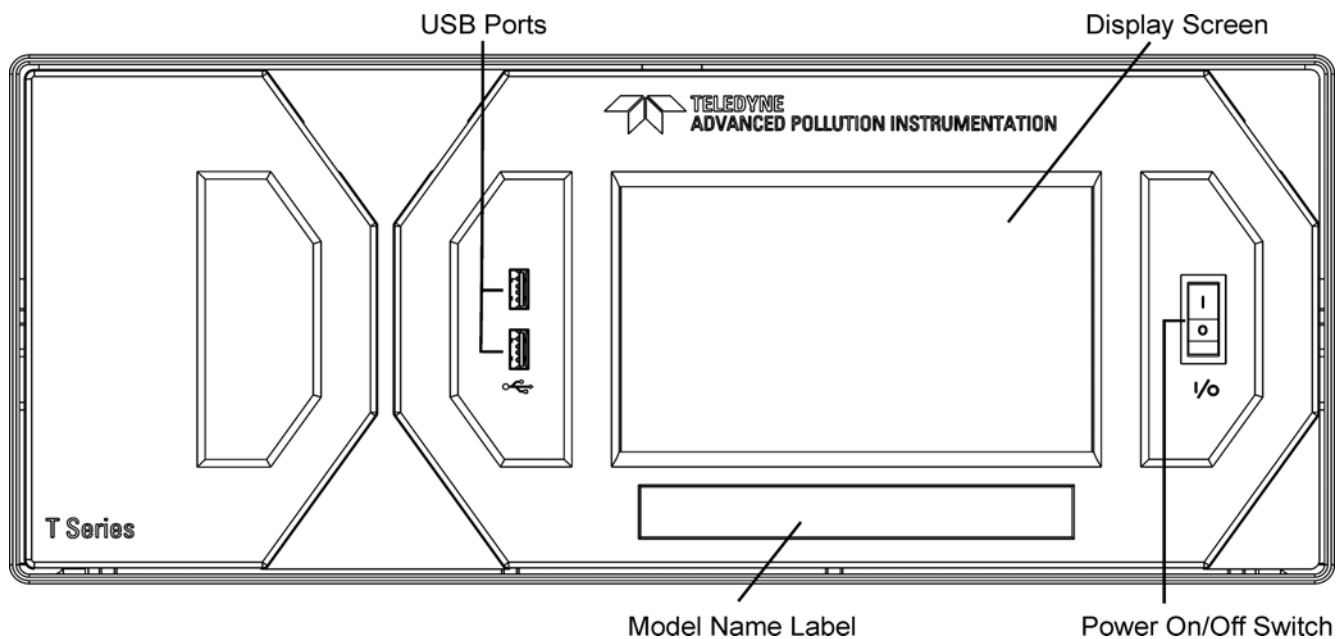

Figure 3-1: Front Panel Layout



Figure 3-2: Display Screen and Touch Control

The front panel liquid crystal display screen includes touch control. Upon analyzer start-up, the screen shows a splash screen and other initialization indicators before the main display appears, similar to Figure 3-2 above. The LEDs on the display screen indicate the Sample, Calibration and Fault states; also on the screen is the gas concentration field (Conc), which displays real-time readouts for the primary gases, NO, NO₂, and NO_x, and for the secondary gas if installed. The display screen also shows what mode the analyzer is currently in, as well as messages and data (Param). Along the bottom of the screen is a row of touch control buttons; only those that are currently applicable will have a label. Table 3-2 provides detailed information for each component of the screen.

ATTENTION

COULD DAMAGE INSTRUMENT AND VOID WARRANTY
Do not use hard-surfaced instruments such as pens to touch the control buttons.

Table 3-2: Display Screen and Touch Control Description

Field	Description/Function			
Status	LEDs indicating the states of Sample, Calibration and Fault, as follows:			
	Name	Color	State	Definition
	SAMPLE	Green	Off	Unit is not operating in sample mode, DAS is disabled.
			On	Sample Mode active; Front Panel Display being updated; DAS data being stored.
			Blinking	Unit is operating in sample mode, front panel display being updated, DAS hold-off mode is ON, DAS disabled
CAL	Yellow	Off	Auto Cal disabled	
		On	Auto Cal enabled	
		Blinking	Unit is in calibration mode	
FAULT	Red	Off	No warnings exist	
		Blinking	Warnings exist	
Conc	Displays the actual concentration of the sample gas currently being measured by the analyzer in the currently selected units of measure.			
Mode	Displays the name of the analyzer's current operating mode			
Param	Displays a variety of informational messages such as warning messages, operational data, test function values and response messages during interactive tasks.			
Control Buttons	Displays dynamic, context sensitive labels on each button, which is blank when inactive until applicable.			

Figure 3-3 shows how the front panel display is mapped to the menu charts illustrated in this manual. The **Mode**, **Param** (parameters), and **Conc** (gas concentration) fields in the display screen are represented across the top row of each menu chart. The eight touch **control buttons** along the bottom of the display screen are represented in the bottom row of each menu chart.

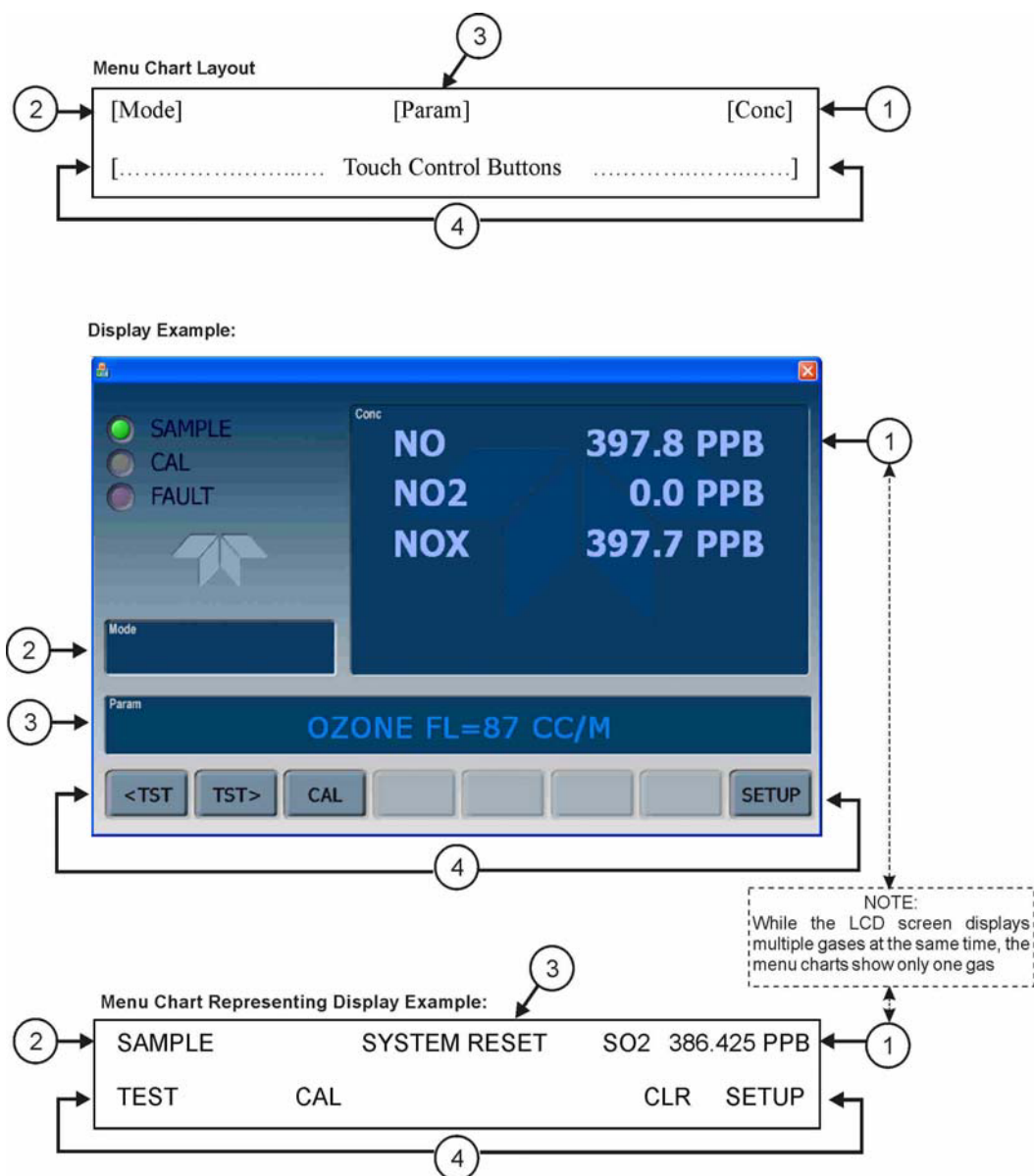

Figure 3-3: Display/Touch Control Screen Mapped to Menu Charts

Note

The menu charts in this manual contain condensed representations of the analyzer’s display during the various operations being described. These menu charts are not intended to be exact visual representations of the actual display.

3.2.2. REAR PANEL

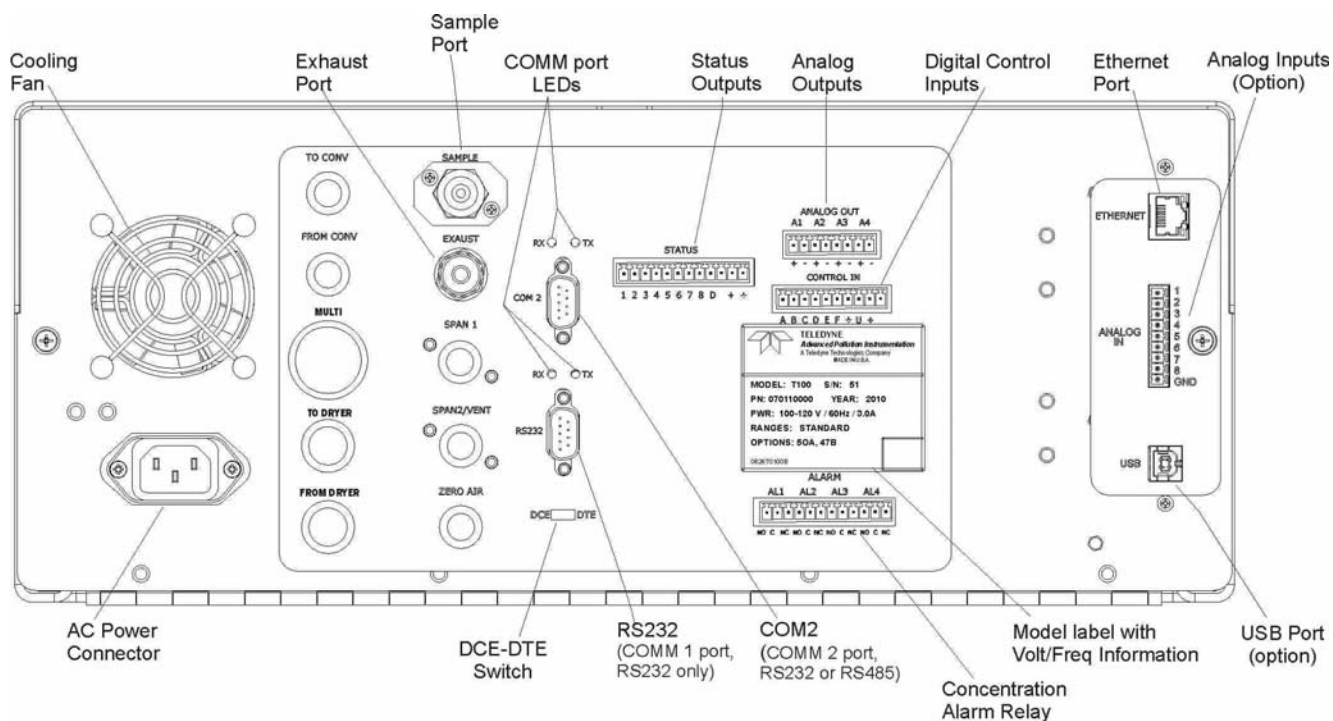



Figure 3-4: Rear Panel Layout – Base Unit

Table 3-3 provides a description of each component on the rear panel.

Table 3-3: Rear Panel Description

Component	Function
cooling fan	Pulls ambient air into chassis through side vents and exhausts through rear.
 AC power connector	Connector for three-prong cord to apply AC power to the analyzer. CAUTION! The cord's power specifications (specs) MUST comply with the power specs on the analyzer's rear panel Model number label
Model/specs label	Identifies the analyzer model number and provides power specs
TO CONV	(not used)
FROM CONV	(not used)
MULTI	(not used)
TO DRYER	(not used)
FROM DRYER	Outlet for internal sample gas dryer; connect to external zero air scrubber (for IZS options only).
SAMPLE	Connect a gas line from the source of sample gas here. Calibration gases can also enter here on units without zero/span/shutoff valve options installed.
EXHAUST	Connect an exhaust gas line of not more than 10 meters long here that leads outside the shelter or immediate area surrounding the instrument. The line must be ¼" tubing or greater.
SPAN 1	On units with zero/span/shutoff valves option installed, connect a gas line to the source of calibrated span gas here.
SPAN2/VENT	On units with pressurized span valve option, used for venting.
ZERO AIR	Internal Zero Air: On units with zero/span/shutoff valves option installed but no internal zero air scrubber attach a gas line to the source of zero air here.
RX TX	LEDs indicate receive (RX) and transmit (TX) activity on the when blinking.
COM 2	Serial communications port for RS-232 or RS-485.
RS-232	Serial communications port for RS-232 only.
DCE DTE	Switch to select either data terminal equipment or data communication equipment during RS-232 communication.
STATUS	For outputs to devices such as Programmable Logic Controllers (PLCs).
ANALOG OUT	For voltage or current loop outputs to a strip chart recorder and/or a data logger.
CONTROL IN	For remotely activating the zero and span calibration modes.
ALARM	Option for concentration alarms and system warnings.
ETHERNET	Connector for network or Internet remote communication, using Ethernet cable
ANALOG IN	Option for external voltage signals from other instrumentation and for logging these signals
USB	Connector for direct connection to laptop computer, using USB cable.
Model Label	Includes voltage and frequency specifications

3.2.3. INTERNAL CHASSIS LAYOUT

Figure 3-5 and Figure 3-6 show internal chassis configurations with different options.

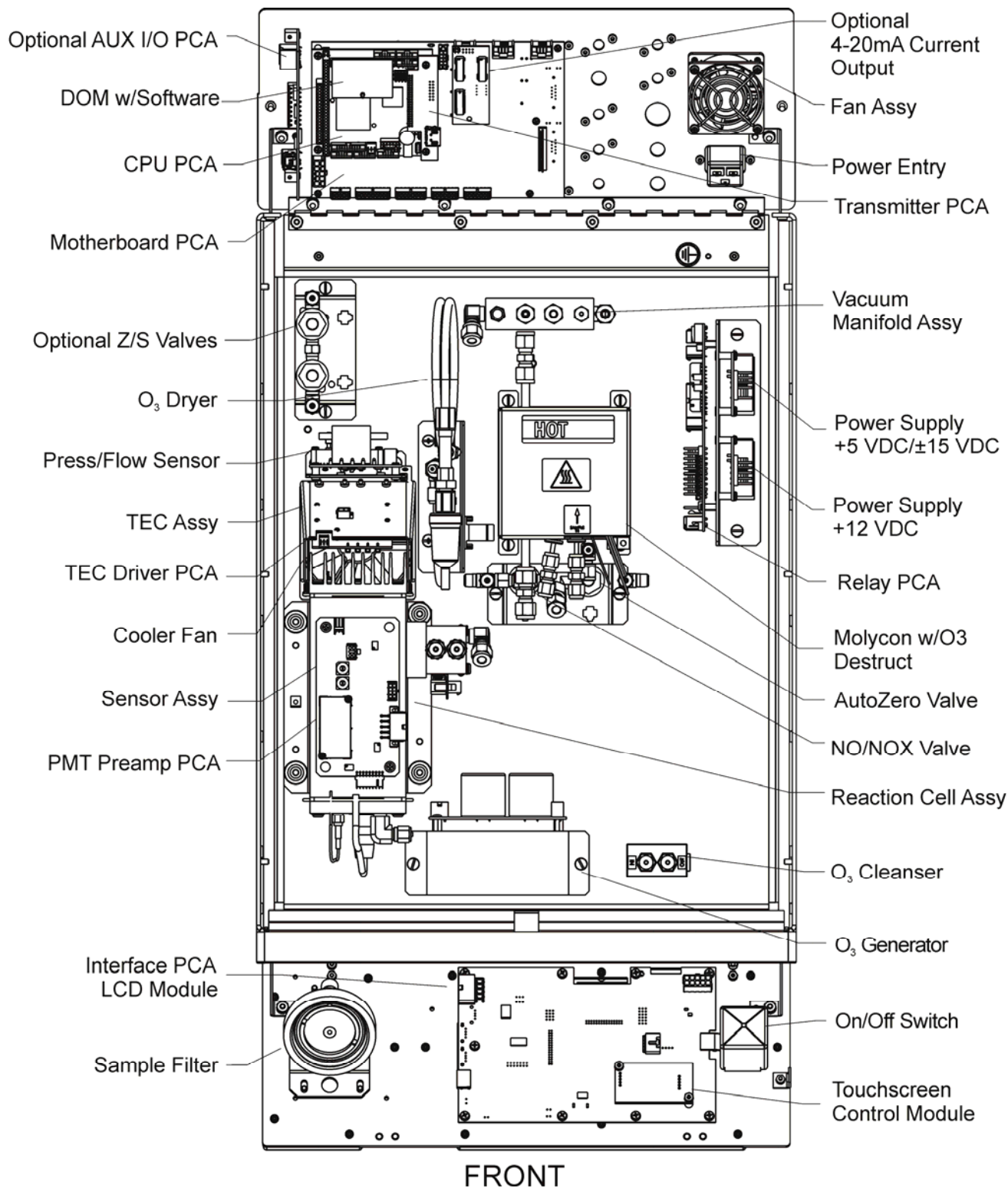

Figure 3-5: Internal Layout – Top View with IZS Option

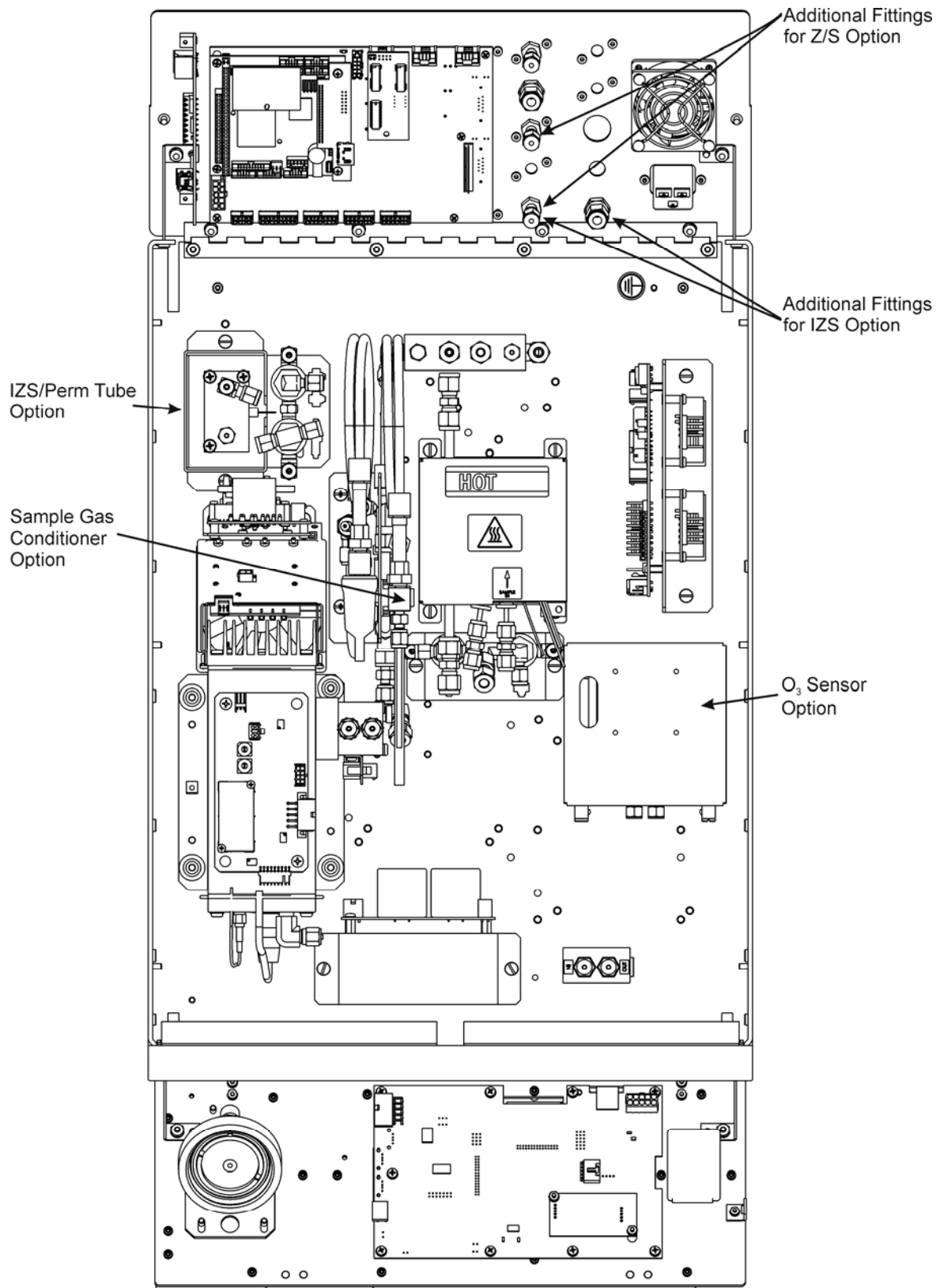

Figure 3-6: Internal Layout - Top View Showing Other Options

3.3. CONNECTIONS AND SETUP

This section presents the electrical (Section 3.3.1) and pneumatic (Section 3.3.2) connections for setup and preparing for instrument operation.

3.3.1. ELECTRICAL CONNECTIONS

Note

To maintain compliance with EMC standards, it is required that the cable length be no greater than 3 meters for all I/O connections, which include Analog In, Analog Out, Status Out, Control In, Ethernet/LAN, USB, RS-232, and RS-485.

This section presents the electrical connections for AC power and communications.

3.3.1.1. Connecting Power

Attach the power cord to the analyzer and plug it into a power outlet capable of carrying at least 10 A current at your AC voltage and that it is equipped with a functioning earth ground.



WARNING
ELECTRICAL SHOCK HAZARD

High Voltages are present inside the analyzers case.
Power connection must have functioning ground connection.
Do not defeat the ground wire on power plug.
Turn off analyzer power before disconnecting or connecting electrical subassemblies.
Do not operate with cover off.



CAUTION
GENERAL SAFETY HAZARD

The 9110T analyzer can be configured for both 100-130 V and 210-240 V at either 47 or 63 Hz.
To avoid damage to your analyzer, ensure that the AC power voltage matches the voltage indicated on the analyzer's model/specs label (Figure 3-4) before plugging the 9110T into line power.

3.3.1.2. Connecting Analog Inputs (Option)

The Analog In connector is used for connecting external voltage signals from other instrumentation (such as meteorological instruments) and for logging these signals in the analyzer's internal DAS. The input voltage range for each analog input is 0-10 VDC.

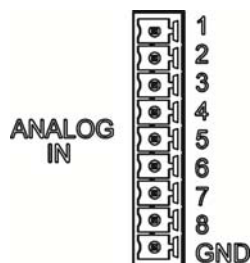

Figure 3-7: Analog In Connector

Pin assignments for the Analog In connector are presented in Table 3-4.

Table 3-4: Analog Input Pin Assignments

PIN	DESCRIPTION	DAS PARAMETER ¹
1	Analog input # 1	AIN 1
2	Analog input # 2	AIN 2
3	Analog input # 3	AIN 3
4	Analog input # 4	AIN 4
5	Analog input # 5	AIN 5
6	Analog input # 6	AIN 6
7	Analog input # 7	AIN 7
8	Analog input # 8	AIN 8
GND	Analog input Ground	N/A

¹ See Section 7 for details on setting up the DAS.

3.3.1.3. Connecting Analog Outputs

The 9110T is equipped with several analog output channels accessible through a connector on the back panel of the instrument.

Output channels **A1**, **A2** and **A3** are assigned to the NO_x, NO and NO₂ concentration signals of the analyzer.

- The default analog output voltage setting of these channels is 0 to 5 VDC with a reporting range of 0 to 500 ppb.
- An optional Current Loop output is available for each.

The output labeled **A4** is special. It can be set by the user to output any one a variety of diagnostic test functions (see Section 5.9.4).

- The default analog output voltage setting of these channels is also 0 to 5 VDC.
- See Section 5.9.4 for a list of available functions and their associated reporting range.
- There is no optional Current Loop output available for Channel A4.

To access these signals attach a strip chart recorder and/or data-logger to the appropriate analog output connections on the rear panel of the analyzer. Pin-outs for the analog output connector are:

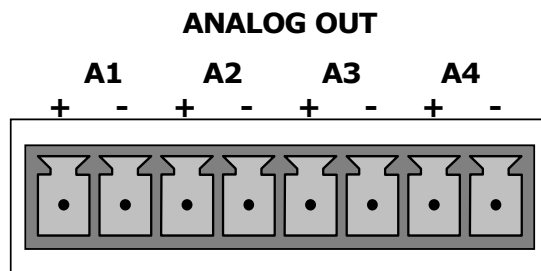

Figure 3-8: Analog Output Connector

Table 3-5: Analog Output Pin Assignments

PIN	ANALOG OUTPUT	SIGNAL	STANDARD VOLTAGE OUTPUT	CURRENT LOOP OPTION
1	A1	NO _x Concentration	V Out	I Out +
2			Ground	I Out -
3	A2	NO Concentration	V Out	I Out +
4			Ground	I Out -
3	A3	NO ₂ Concentration	V Out	I Out +
4			Ground	I Out -
7	A4 ¹	TEST CHANNEL	V Out	Not Available
8			Ground	Not Available

To change the settings for the analog output channels, see Section 5.9.2.

3.3.1.4. Current Loop Analog Outputs (Option 41) Setup

If your analyzer had this option installed at the factory, there are no further connections to be made. Otherwise, it can be installed as a retrofit for each of the analog outputs of the analyzer. This option converts the DC voltage analog output to a current signal with 0-20 mA output current. The outputs can be scaled to any set of limits within that 0-20 mA range. However, most current loop applications call for either 2-20 mA or 4-20 mA range. All current loop outputs have a +5% over-range. Ranges with the lower limit set to more than 1 mA (e.g., 2-20 or 4-20 mA) also have a -5% under-range.

Figure 3-9 provides installation instructions and illustrates a sample combination of one current output and two voltage outputs configuration. This section provides instructions for converting current loop analog outputs to standard 0-to-5 VDC outputs. Information on calibrating or adjusting these outputs can be found in Section 5.9.3.7.

CAUTION – AVOID INVALIDATING WARRANTY



Servicing or handling of circuit components requires electrostatic discharge protection, i.e. ESD grounding straps, mats and containers. Failure to use ESD protection when working with electronic assemblies will void the instrument warranty. Refer to Section 14 for more information on preventing ESD damage.

J19, J21, J23 Analog Output Setup:

- For **voltage** output of any one, two, or all:
 1. Jumper two leftmost pins.
 2. Jumper next two leftmost pins.
 3. Calibrate per Analog I/O Configuration menu.

- For **current** output of any one, two, or all:
 1. Remove jumper shunts.
 2. Install Current Loop option.
 3. Calibrate per Analog I/O Configuration menu.

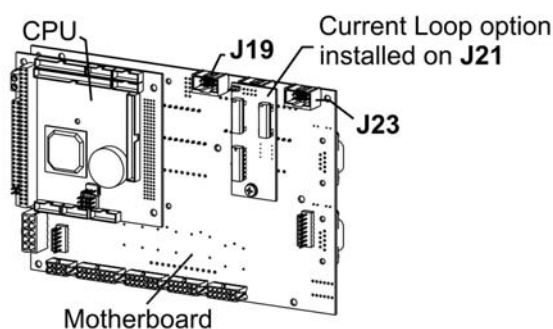
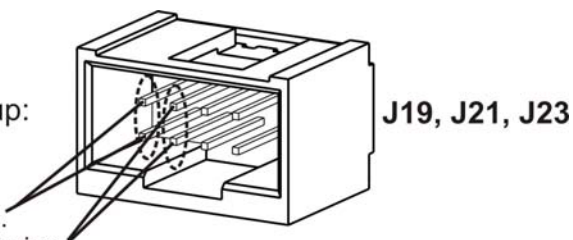

Example setup: install jumper shunts for voltage output on J19 and J23; remove jumper shunts and install Current Loop option for current output on J21.

Figure 3-9: Current Loop Option Installed on the Motherboard

CONVERTING CURRENT LOOP ANALOG OUTPUTS TO STANDARD VOLTAGE OUTPUTS

To convert an output configured for current loop operation to the standard 0 to 5 VDC output operation:

1. Turn off power to the analyzer.
8. If a recording device was connected to the output being modified, disconnect it.
9. Remove the top cover.
 - Remove the set screw located in the top, center of the rear panel.
 - Remove the screws fastening the top cover to the unit (one per side).
 - Slide the cover back and lift the cover straight up.
10. Remove the screw holding the current loop option to the motherboard.
11. Disconnect the current loop option PCA from the appropriate connector on the motherboard (see Figure 3-9).
12. Each connector, J19 and J23, requires two shunts. Place one shunt on the two left most pins and the second shunt on the two adjacent pins (see Figure 3-9).
13. Reattach the top case to the analyzer.

The analyzer is now ready to have a voltage-sensing, recording device attached to that output.

Calibrate the analog output as described in Section 5.9.3.2.

3.3.1.5. Connecting the Status Outputs

The status outputs report analyzer conditions via optically isolated NPN transistors, which sink up to 50 mA of DC current. These outputs can be used interface with devices that accept logic-level digital inputs, such as Programmable Logic Controllers (PLCs). Each Status bit is an open collector output that can withstand up to 40 VDC. All of the emitters of these transistors are tied together and available at pin D.

ATTENTION

COULD DAMAGE INSTRUMENT AND VOID WARRANTY

Most PLC's have internal provisions for limiting the current that the input will draw from an external device. When connecting to a unit that does not have this feature, an external dropping resistor must be used to limit the current through the transistor output to less than 50 mA. At 50 mA, the transistor will drop approximately 1.2V from its collector to emitter.

The status outputs are accessed via a 12-pin connector on the analyzer's rear panel labeled STATUS (Figure 3-4). Pin-outs for this connector are:

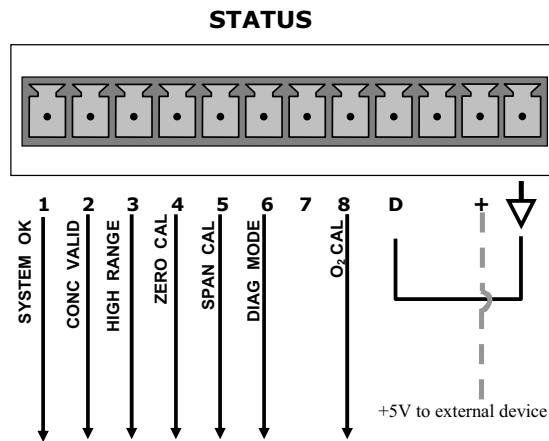

Figure 3-10: Status Output Connector

Table 3-6: Status Output Pin Assignments

OUTPUT #	STATUS DEFINITION	CONDITION
1	SYSTEM OK	On if no faults are present.
2	CONC VALID	On if O ₃ concentration measurement is valid. If the O ₃ concentration measurement is invalid, this bit is OFF.
3	HIGH RANGE	On if unit is in high range of DUAL or AUTO Range Modes.
4	ZERO CAL	On whenever the instrument is in CALZ mode.
5	SPAN CAL	On whenever the instrument is in CALS mode.

6	DIAG MODE	On whenever the instrument is in DIAGNOSTIC mode.
7-8	SPARE	
D	Emitter BUS	The emitters of the transistors on pins 1 to 8 are bussed together.
	SPARE	
+	DC Power	+ 5 VDC, 300 mA source maximum
↓	Digital Ground	The ground level from the analyzer's internal DC power supplies. This connection should be used as the ground return when +5VDC power is used.

3.3.1.6. Connecting the Control Inputs

The analyzer is equipped with three digital control inputs that can be used to remotely activate the zero and span calibration modes (see Section 9.1.2.4). Access to these inputs is provided via a 10-pin connector labeled CONTROL IN on the analyzer's rear panel.

There are two methods for energizing the Control Inputs. The internal +5V available from the pin labeled "+" is the most convenient method however, to ensure that these inputs are truly isolated; a separate external 5 VDC power supply should be used.

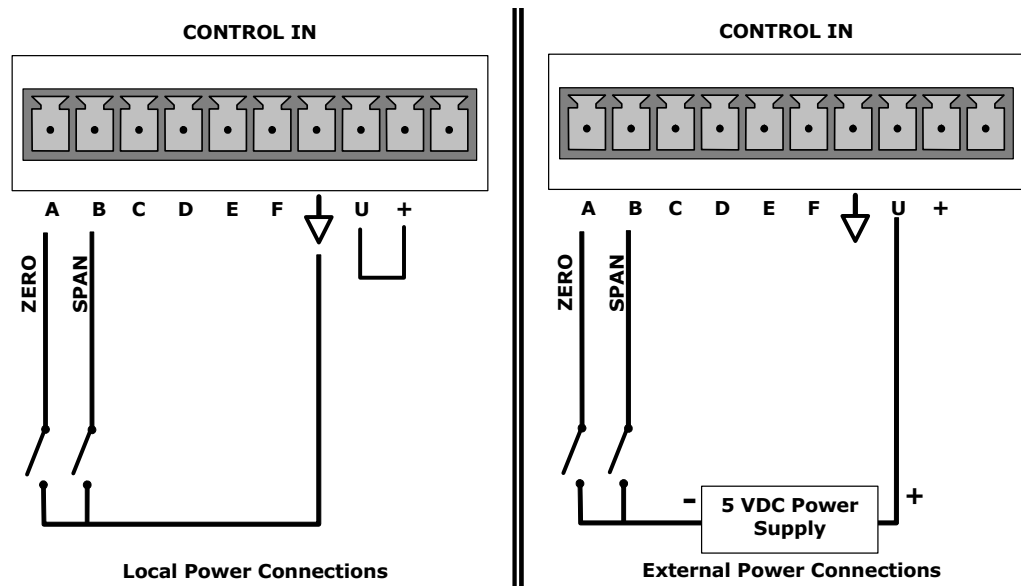

Figure 3-11: Energizing the 9110T Control Inputs

Table 3-7: Control Input Pin Assignments

Input #	Status Definition	ON Condition
A	REMOTE ZERO CAL	The Analyzer is placed in Zero Calibration mode. The mode field of the display will read ZERO CAL R.
B	REMOTE SPAN CAL	The Analyzer is placed in Lo Span Calibration mode. The mode field of the display will read SPAN CAL R.
C, D, E & F	Spare	

↓	Digital Ground	The ground level from the analyzer’s internal DC Power Supplies (same as chassis ground).
U	External Power input	Input pin for +5 VDC required to activate pins A – F.
+	5 VDC output	Internally generated 5V DC power. To activate inputs A – F, place a jumper between this pin and the “U” pin. The maximum amperage through this port is 300 mA (combined with the analog output supply, if used).

3.3.1.7. Concentration Alarm Relay (Option 61)

The TAI “E” series analyzers have an option for four (4) “dry contact” relays on the rear panel of the instrument. This relay option is different from and in addition to the “Contact Closures” that come standard on all TAPI instruments. The relays have 3 pins that have connections on the rear panel (refer Figure 3-12). They are a Common (C), a Normally Open (NO), & a Normally Closed (NC) pin.

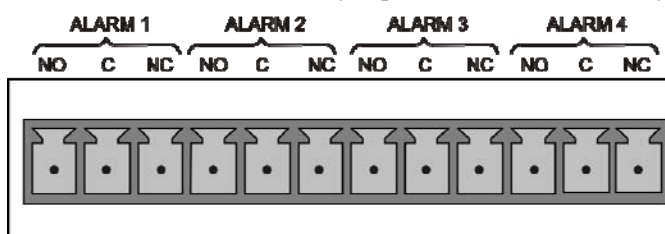

Figure 3-12: Concentration Alarm Relay

- Alarm 1 “System OK 2”
- Alarm 2 “Conc 1”
- Alarm 3 “Conc 2”
- Alarm 4 “Range Bit”

“ALARM 1” RELAY

Alarm 1 which is “System OK 2” (system OK 1, is the status bit) is in the energized state when the instrument is “OK” & there are no warnings. If there is a warning active or if the instrument is put into the “DIAG” mode, Alarm 1 will change states. This alarm has “reverse logic” meaning that if you put a meter across the Common & Normally Closed pins on the connector you will find that it is OPEN when the instrument is OK. This is so that if the instrument should turn off or lose power, it will change states & you can record this with a data logger or other recording device.

“ALARM 2” RELAY & “ALARM 3” RELAY

The “Alarm 2 Relay” on the rear panel, is associated with the “Concentration Alarm 1” set point in the software & the “Alarm 3 Relay” on the rear panel is associated with the “Concentration Alarm 2” set point in the software.

Alarm 2 Relay NO Alarm 1 = xxx PPM

Alarm 3 Relay	NO2 Alarm 2 = xxx PPM
Alarm 2 Relay	NOX Alarm 1 = xxx PPM
Alarm 3 Relay	NOX Alarm 2 = xxx PPM

The Alarm 2 Relay will be turned on any time the concentration set-point is exceeded & will return to its normal state when the concentration value goes back below the concentration set-point.

Even though the relay on the rear panel is a NON-Latching alarm & resets when the concentration goes back below the alarm set point, the warning on the front panel of the instrument will remain latched until it is cleared. You can clear the warning on the front panel by either pushing the CLR button on the front panel or through the serial port.

In instruments that sample more than one gas type, there could be more than one gas type triggering the Concentration 1 Alarm (“Alarm 2” Relay). For example, the 9110T instrument can monitor both NO & NO₂ gas. The software for this instrument is flexible enough to allow you to configure the alarms so that you can have 2 alarm levels for each gas.

NO Alarm 1 = 20 PPM
NO Alarm 2 = 100 PPM
NO2 Alarm 1 = 20 PPM
NO2 Alarm 2 = 100 PPM

In this example, NO Alarm 1 & NO₂ Alarm 1 will both be associated with the “Alarm 2” relay on the rear panel. This allows you do have multiple alarm levels for individual gases.

A more likely configuration for this would be to put one gas on the “Alarm 1” relay and the other gas on the “Alarm 2” relay.

NO Alarm 1 = 20 PPM
NO Alarm 2 = Disabled
NO₂ Alarm 1 = Disabled
NO₂ Alarm 2 = 100 PPM

“ALARM 4” RELAY

This relay is connected to the “range bit”. If the instrument is configured for “Auto Range” and the instrument goes up into the high range, it will turn this relay on.

3.3.1.8. Connecting the Communications Interfaces

The T-Series analyzers are equipped with connectors for remote communications interfaces: **Ethernet**, **USB**, **RS-232**, **RS-232 Multidrop** and **RS-485** (each described here). In addition to using the

appropriate cables, each type of communication method, must be configured using the SETUP>COMM menu (see Sections 5.7 and 6).

ETHERNET CONNECTION

For network or Internet communication with the analyzer, connect an Ethernet cable from the analyzer's rear panel Ethernet interface connector to an Ethernet port. Although the analyzer is shipped with DHCP enabled by default (Section 6.5.2), it should be manually assigned a static IP address.

Configuration: (manual, i.e., static) Section 6.5.1.

USB CONNECTION

The USB option can be used for direct communication between the analyzer and a PC; connect a USB cable between the analyzer and computer USB ports. Baud rates must match: check the baud rate on either the computer or the instrument and change the other to match (see Section 6.2.2). This USB connection can only be used when the **COM2** port is not in use except for RS-232 Multidrop communication.

Configuration: Section 6.6.

Note

If this option is installed, the rear panel COM2 port cannot be used for anything other than Multidrop communication.

RS-232 CONNECTION

For **RS-232** communications with data terminal equipment (**DTE**) or with data communication equipment (**DCE**) connect either a DB9-female-to-DB9-female cable (TAI part number WR000077) or a DB9-female-to-DB25-male cable (Option 60A, Section 1.4), as applicable, from the analyzer's rear panel RS-232 port to the device. Adjust the DCE-DTE switch (Figure 3-4) to select DTE or DCE as appropriate (Section 6.1).

Configuration: Section 6.3.

IMPORTANT

IMPACT ON READINGS OR DATA

Cables that appear to be compatible because of matching connectors may incorporate internal wiring that makes the link inoperable. Check cables acquired from sources other than TAI for pin assignments (Figure 3-13) before using.

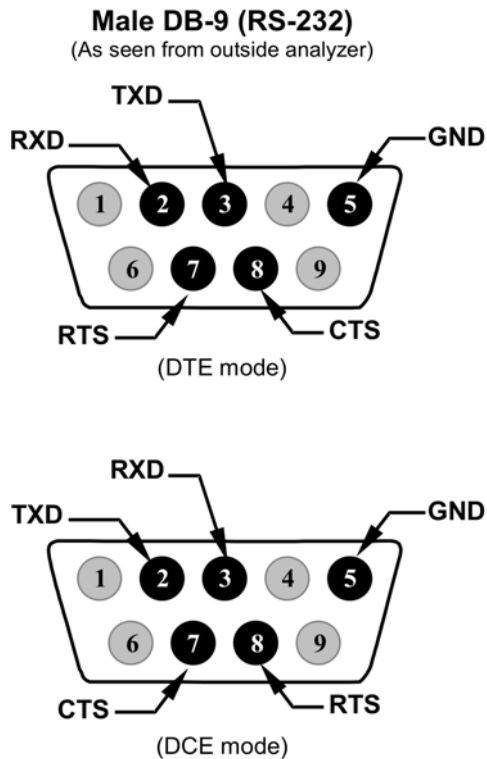

Figure 3-13 Rear Panel Connector Pin-Outs for RS-232 Mode

The signals from these two connectors are routed from the motherboard via a wiring harness to two 10-pin connectors on the CPU card, J11 and J12 (Figure 3-14).

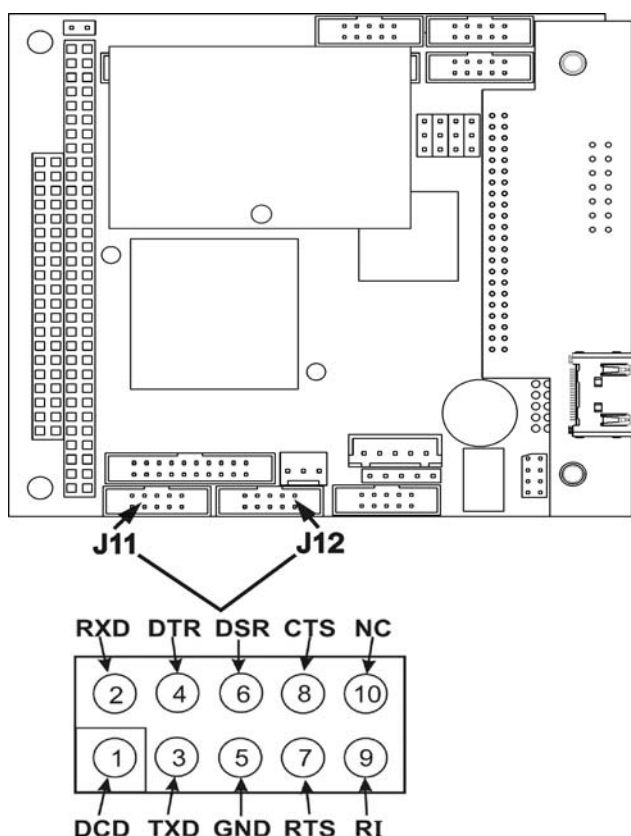

Figure 3-14: Default Pin Assignments for CPU COMM Port Connector (RS-232).

TAI offers two mating cables, one of which should be applicable for your use.

- P/N WR000077, a DB-9 female to DB-9 female cable, 6 feet long. Allows connection of the serial ports of most personal computers.
- P/N WR000024, a DB-9 female to DB-25 male cable. Allows connection to the most common styles of modems (e.g. Hayes-compatible) and code activated switches.

Both cables are configured with straight-through wiring and should require no additional adapters.

Note

Cables that appear to be compatible because of matching connectors may incorporate internal wiring that makes the link inoperable. Check cables acquired from sources other than TAI for pin assignments before using.

To assist in properly connecting the serial ports to either a computer or a modem, there are activity indicators just above the RS-232 port. Once a cable is connected between the analyzer and a computer or modem, both the red and green LEDs should be on.

- If the lights are not lit, locate the small switch on the rear panel to switch it between DTE and DCE modes.
- If both LEDs are still not illuminated, ensure that the cable properly constructed.

Received from the factory, the analyzer is set up to emulate an RS-232 DCE device.

RS-232 (COM1): RS-232 (fixed) DB-9 male connector

- **Baud rate:** 115200 bits per second (baud)
- **Data Bits:** 8 data bits with 1 stop bit
- **Parity:** None

COM2: RS-232 (configurable to RS 485), DB-9 female connector

- Baud rate: 19200 bits per second (baud)
- Data Bits: 8 data bits with 1 stop bit
- Parity: None

RS-232 MULTIDROP (OPTION 62) CONNECTION

When the RS-232 Multidrop option is installed, connection adjustments and configuration through the menu system are required. This section provides instructions for the internal connection adjustments, then for external connections, and ends with instructions for menu-driven configuration.

Note

Because the RS-232 Multidrop option uses both the RS232 and COM2 DB9 connectors on the analyzer's rear panel to connect the chain of instruments, COM2 port is no longer available for separate RS-232 or RS-485 operation.

ATTENTION

COULD DAMAGE INSTRUMENT AND VOID WARRANTY
Printed Circuit Assemblies (PCAs) are sensitive to electro-static discharges too small to be felt by the human nervous system. Failure to use ESD protection when working with electronic assemblies will void the instrument warranty. Refer to Section 14 for more information on preventing ESD damage.

In each instrument with the Multidrop option there is a shunt jumpering two pins on the serial Multidrop and LVDS printed circuit assembly (PCA), as shown in Figure 3-15. This shunt must be removed from all instruments except that designated as last in the multidrop chain, which must remain terminated. This requires powering off and opening each instrument and making the following adjustments:

1. With **NO power** to the instrument, remove its top cover and lay the rear panel open for access to the Multidrop/LVDS PCA, which is seated on the CPU.
2. On the Multidrop/LVDS PCA's JP2 connector, remove the shunt that jumpers Pins 21 ↔ 22 as indicated in. (Do this for all but the last instrument in the chain where the shunt should remain at Pins 21 ↔ 22).
3. Check that the following cable connections are made in *all* instruments (again refer to Figure 3-15):
 - J3 on the Multidrop/LVDS PCA to the CPU's COM1 connector

1. (Note that the CPU's COM2 connector is not used in Multidrop)
 - J4 on the Multidrop/LVDS PCA to J12 on the motherboard
 - J1 on the Multidrop/LVDS PCS to the front panel LCD

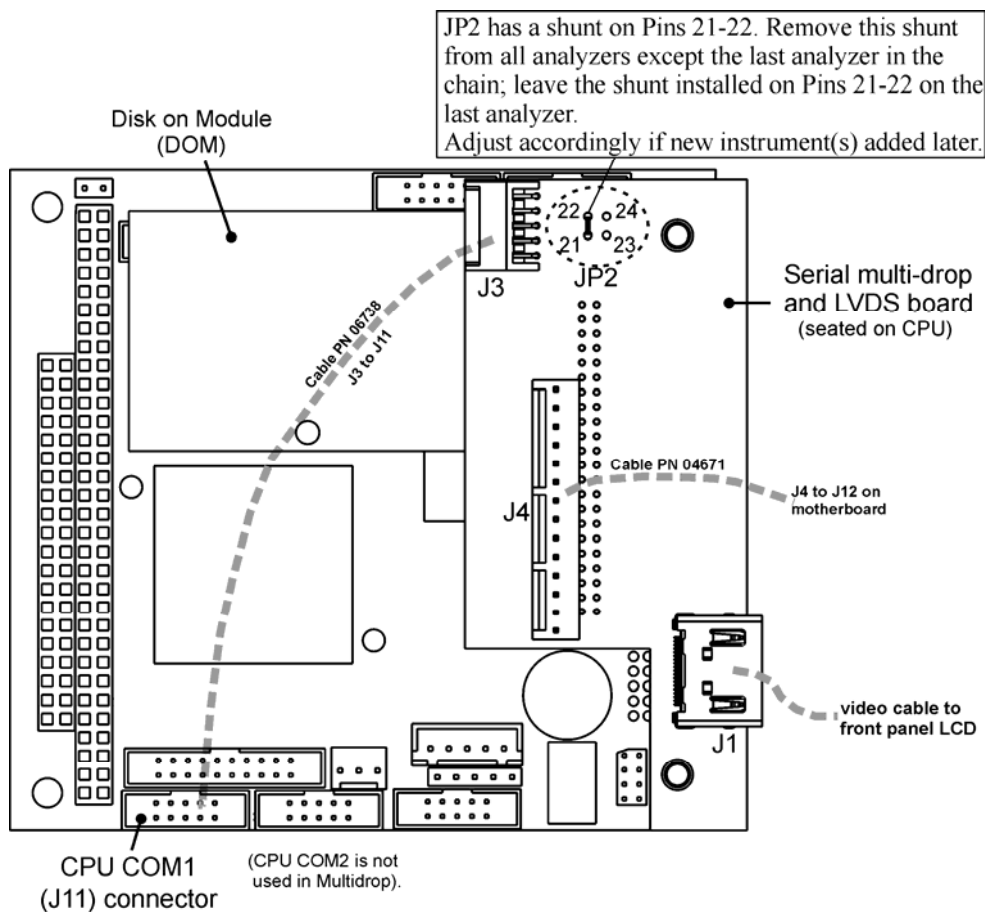

Figure 3-15: Jumper and Cables for Multidrop Mode

2. (Note: If you are adding an instrument to the end of a previously configured chain, remove the shunt between Pins 21 ↔ 22 of JP2 on the Multidrop/LVDS PCA in the instrument that was previously the last instrument in the chain.)
4. Close the instrument.
5. Referring to Figure 3-16 use straight-through DB9 male → DB9 female cables to interconnect the host RS232 port to the first analyzer's RS232 port; then from the first analyzer's COM2 port to the second analyzer's RS232 port; from the second analyzer's COM2 port to the third analyzer's RS232 port, etc., connecting in this fashion up to eight analyzers, subject to the distance limitations of the RS-232 standard.
6. On the rear panel of each analyzer, adjust the DCE DTE switch so that the green and the red LEDs (RX and TX) of the COM1 connector (labeled RS232) are both lit. (Ensure you are using the correct RS-232 cables internally wired specifically for RS-232 communication; see Table 1-1, "Communication Cables" and Section 3.3.1.8: Connecting the Communications Interfaces, "RS-232 Connection").

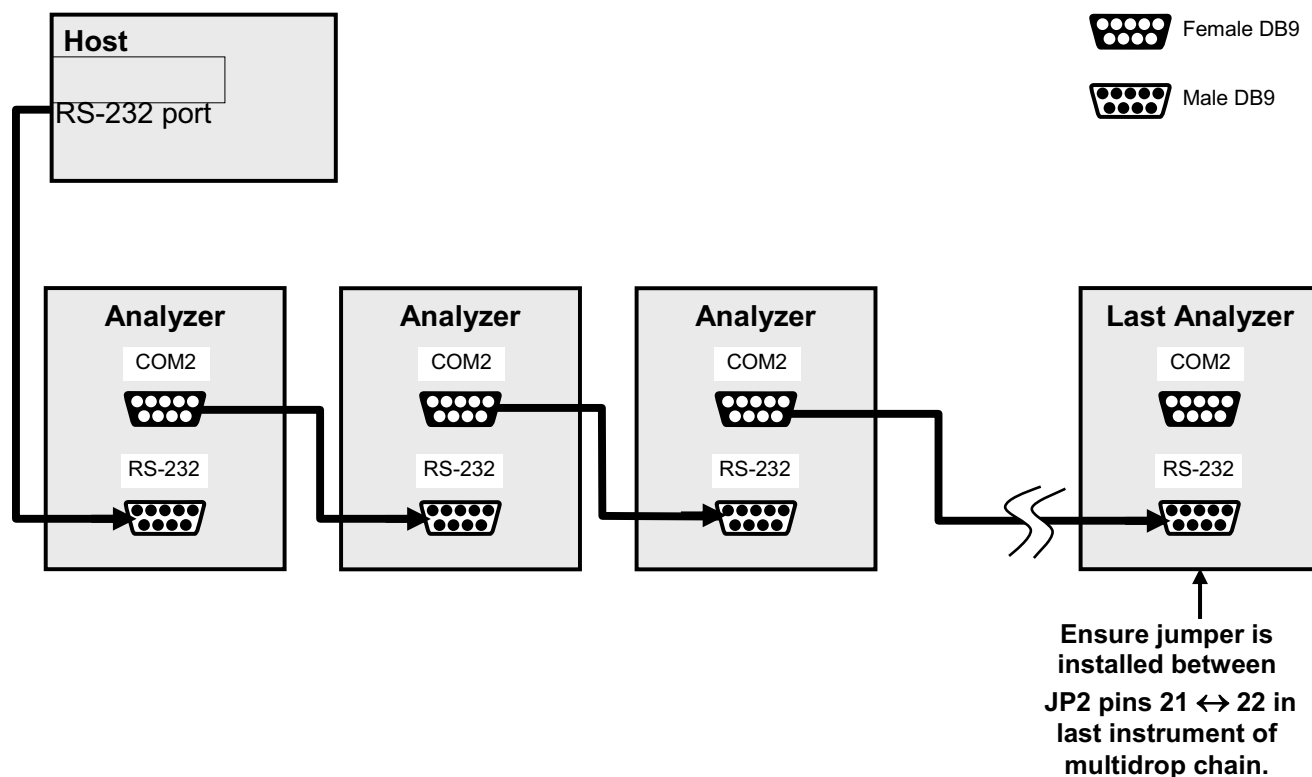

Figure 3-16: RS-232-Multidrop PCA Host/Analyzer Interconnect Diagram

7. BEFORE communicating from the host, power on the instruments and check that the Machine ID code is unique for each (Section 5.7.1).
3. a. In the SETUP Mode menu go to SETUP>MORE>COMM>ID. The default ID is typically the model number or "0".
4. b. to change the identification number, press the button below the digit to be changed.
5. c. Press/select ENTER to accept the new ID for that instrument.
8. Next, in the SETUP>MORE>COMM>COM1 menu (do not use the COM2 menu for multidrop), edit the COM1 MODE parameter as follows: press/select EDIT and set only QUIET MODE, COMPUTER MODE, and MULTIDROP MODE to ON. Do not change any other settings.
9. Press/select ENTER to accept the changed settings, and ensure that COM1 MODE now shows 35.
10. Press/select SET> to go to the COM1 BAUD RATE menu and ensure it reads the same for all instruments (edit as needed so that all instruments are set at the same baud rate).

Note

The (communication) Host instrument can address only one instrument at a time, each by its unique ID (see step 7 above).

Note

TAI recommends setting up the first link, between the Host and the first analyzer, and testing it before setting up the rest of the chain.

RS-485 CONNECTION

As delivered from the factory, **COM2** is configured for RS-232 communications. This port can be reconfigured for operation as a non-isolated, half-duplex RS-485 port. Using COM2 for RS-485 communication will disable the USB port. To reconfigure this port for RS-485 communication, please contact the factory.

3.3.2. PNEUMATIC CONNECTIONS

This section provides not only pneumatic connection information, but also important information about the gases required for accurate calibration (Section 3.3.2.1); it also illustrates the pneumatic layouts for the analyzer in its basic configuration and with options.

Before making the pneumatic connections, carefully note the following cautionary and additional messages:

**CAUTION
GENERAL SAFETY HAZARD**

Do not vent calibration gas or sample gas into enclosed areas.

**CAUTION – GENERAL SAFETY HAZARD**

In units with a permeation tube option installed, vacuum pump must be connected and powered on to maintain constant gas flow through the analyzer at all times. Insufficient gas flow allows gas to build up to levels that will contaminate the instrument or present a safety hazard to personnel.

Remove permeation tube when taking analyzer out of operation, and store in sealed container (use original container that tube was shipped in).

(See Figure 3-6 for location and Section 11.3.6 for instructions on how to remove the perm tube when the unit is not in operation).

IMPORTANT**IMPACT ON READINGS OR DATA**

Sample and calibration gases should only come into contact with PTFE tubing.

ATTENTION**COULD DAMAGE INSTRUMENT AND VOID WARRANTY****Venting Pressurized Gas:**

In applications where any gas (span gas, zero air supply, sample gas) is received from a pressurized manifold, a vent must be provided to equalize the gas with ambient atmospheric pressure before it enters the analyzer to ensure that the gases input do not exceed the maximum inlet pressure of the analyzer, as well as to prevent back diffusion and pressure effects.

These vents should be:

- at least 0.2m long
- no more than 2m long
- vented outside the shelter or immediate area surrounding the instrument.

Dust Plugs:

Remove dust plugs from rear panel exhaust and supply line fittings before powering on/operating instrument. These plugs should be kept for reuse in the event of future storage or shipping to prevent debris from entering the pneumatics.

IMPORTANT**Leak Check:**

Run a leak check once the appropriate pneumatic connections have been made; check all pneumatic fittings for leaks using the procedures defined in Section 11.3.12.1.

3.3.2.1. About Zero Air and Calibration (Span) Gas

Zero air and span gas are required for accurate calibration.

Note

Zero air and span gases must be supplied at twice the instrument's specified gas flow rate. Therefore, the 9110T zero and span gases should be supplied to their respective inlets in excess of 1000 cc3/min (500 cc3/min x 2).

ZERO AIR

Zero air or zero calibration gas is defined as a gas that is similar in chemical composition to the measured medium but without the gas to be measured by the analyzer.

For the 9110T this means zero air should be devoid of NO, NO₂, CO₂, NH₃ or H₂O vapor.

Note

Moderate amounts of NH₃ and H₂O can be removed from the sample gas stream by installing the optional sample gas dryer/scrubber (see Section 3.3.2.6).

- If your application is not a measurement in ambient air, the zero calibration gas should be matched to the composition of the gas being measured.

- Pure nitrogen (N₂) could be used as a zero gas for applications where NO_x is measured in nitrogen.
- If your analyzer is equipped with an external zero air scrubber option, it is capable of creating zero air from ambient air.
- For analyzers without the external zero air scrubber, a zero air generator such as the Teledyne Model 701 can be used. Please visit the company website for more information.

CALIBRATION (SPAN) GAS

Calibration gas is a gas specifically mixed to match the chemical composition of the type of gas being measured at near full scale of the desired reporting range. To measure NO_x with the 9110T NO_x analyzer, it is recommended that you use a span gas with an NO concentration equal to 80% of the measurement range for your application

EXAMPLE:

- If the application is to measure NO_x in ambient air between 0 ppm and 500 ppb, an appropriate span gas would be 400 ppb.
- If the application is to measure NO_x in ambient air between 0 ppm and 1000 ppb, an appropriate span gas would be 800 ppb.

Even though NO gas in nitrogen could be used as a span gas, the matrix of the balance gas is different and may cause interference problems or yield incorrect calibrations.

- The same applies to gases that contain high concentrations of other compounds (for example, CO₂ or H₂O).
- The span gas should match all concentrations of all gases of the measured medium as closely as possible.

Cylinders of the following types of calibrated NO_x and NO gas traceable to NIST standards specifications (also referred to as EPA protocol calibration gases or Standard Reference Materials) are commercially available.

Table 3-8: NIST-SRM's Available for Traceability of NO_x Calibration Gases

NIST-SRM ⁴	TYPE	NOMINAL CONCENTRATION
2627a	Nitric Oxide (NO) in N ₂	5 ppm
2628a	Nitric Oxide (NO) in N ₂	10 ppm
2629a	Nitric Oxide (NO) in N ₂	20 ppm
1683b	Nitric Oxide (NO) in N ₂	50 ppm
1684b	Nitric Oxide (NO) in N ₂	100 ppm
1685b	Nitric Oxide (NO) in N ₂	250 ppm
1686b	Nitric Oxide (NO) in N ₂	5000 ppm
1687b	Nitric Oxide (NO) in N ₂	1000 ppm
2630	Nitric Oxide (NO) in N ₂	1500 ppm
2631a	Nitric Oxide (NO) in N ₂	3000 ppm
2635	Nitric Oxide (NO) in N ₂	800 ppm
2636a	Nitric Oxide (NO) in N ₂	2000 ppm
2631a	Oxides of Nitrogen (NO _x) in N ₂	2500 ppm
1684b	Oxides of Nitrogen (NO _x) in N ₂	100 ppm

Note

The NO₂ permeation tube included with the 9110T's optional Internal

Zero Air generator (IZS) has a limited accuracy of about $\pm 5\%$.

While NO₂ permeation tubes may be sufficient for informal calibration checks, they are not approved by the US EPA as calibration sources for performing actual calibration of the analyzer.

SPAN GAS FOR MULTIPOINT CALIBRATION

Some applications, such as EPA monitoring, require a multipoint calibration where span gases of different concentrations are needed. We recommend using an NO gas of higher concentration combined with a gas dilution calibrator such as a Teledyne Model 700E. This type of calibrator mixes a high concentration gas with zero air to accurately produce span gas of the desired concentration. Linearity profiles can be automated with this model and run unattended overnight.

If a dynamic dilution system such as the Teledyne Model 700 is used to dilute high concentration gas standards to low, ambient concentrations, ensure that the NO concentration of the reference gas matches the dilution range of the calibrator.

Choose the NO gas concentration so that the dynamic dilution system operates in its mid-range and not at the extremes of its dilution capabilities.

EXAMPLE:

- A dilution calibrator with 10-10000 dilution ratio will not be able to accurately dilute a 5000 ppm NO gas to a final concentration of 500 ppb, as this would operate at the very extreme dilution setting.
- A 100 ppm NO gas in nitrogen is much more suitable to calibrate the 9110T analyzer (dilution ratio of 222, in the mid-range of the system's capabilities).

3.3.2.2. Basic Connections from Calibrator, without and With Span Gas

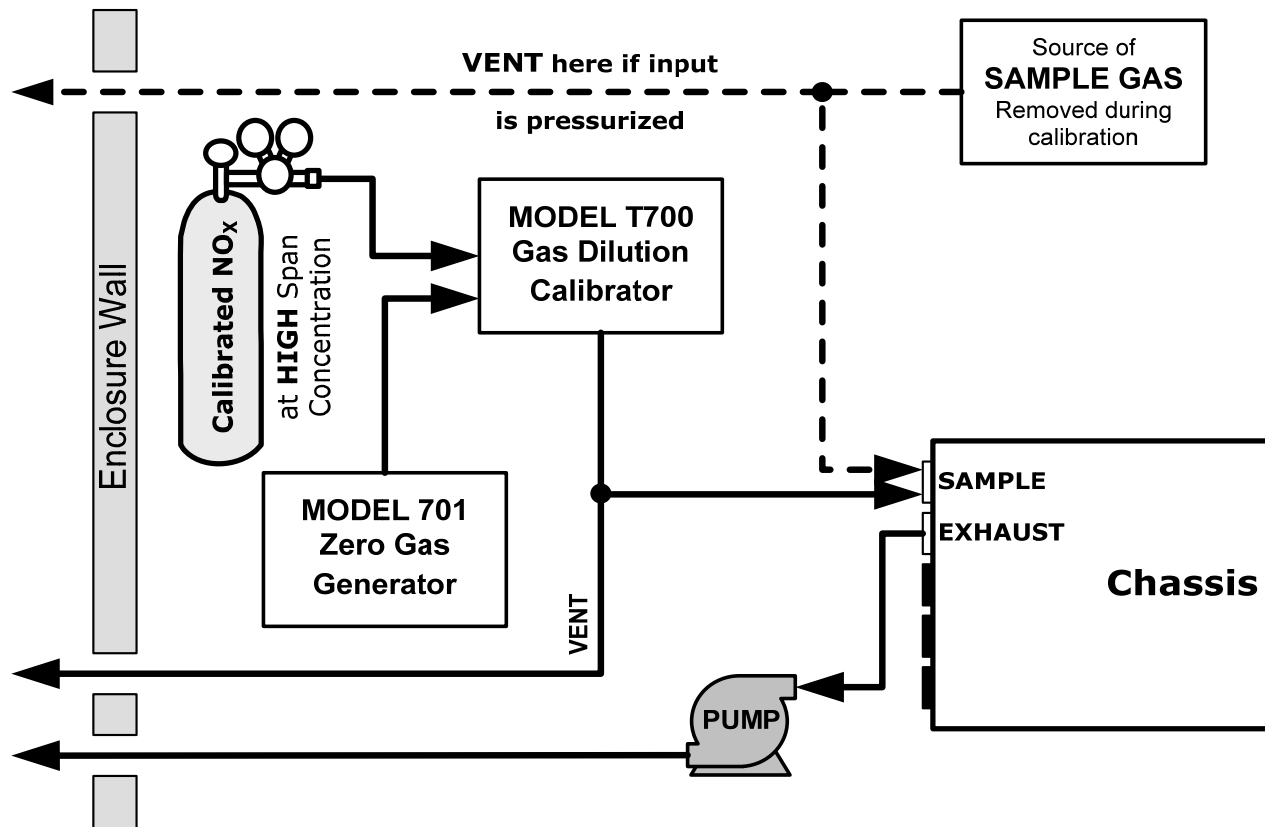

Figure 3-17: Gas Line Connections from Calibrator – Basic 9110T Configuration

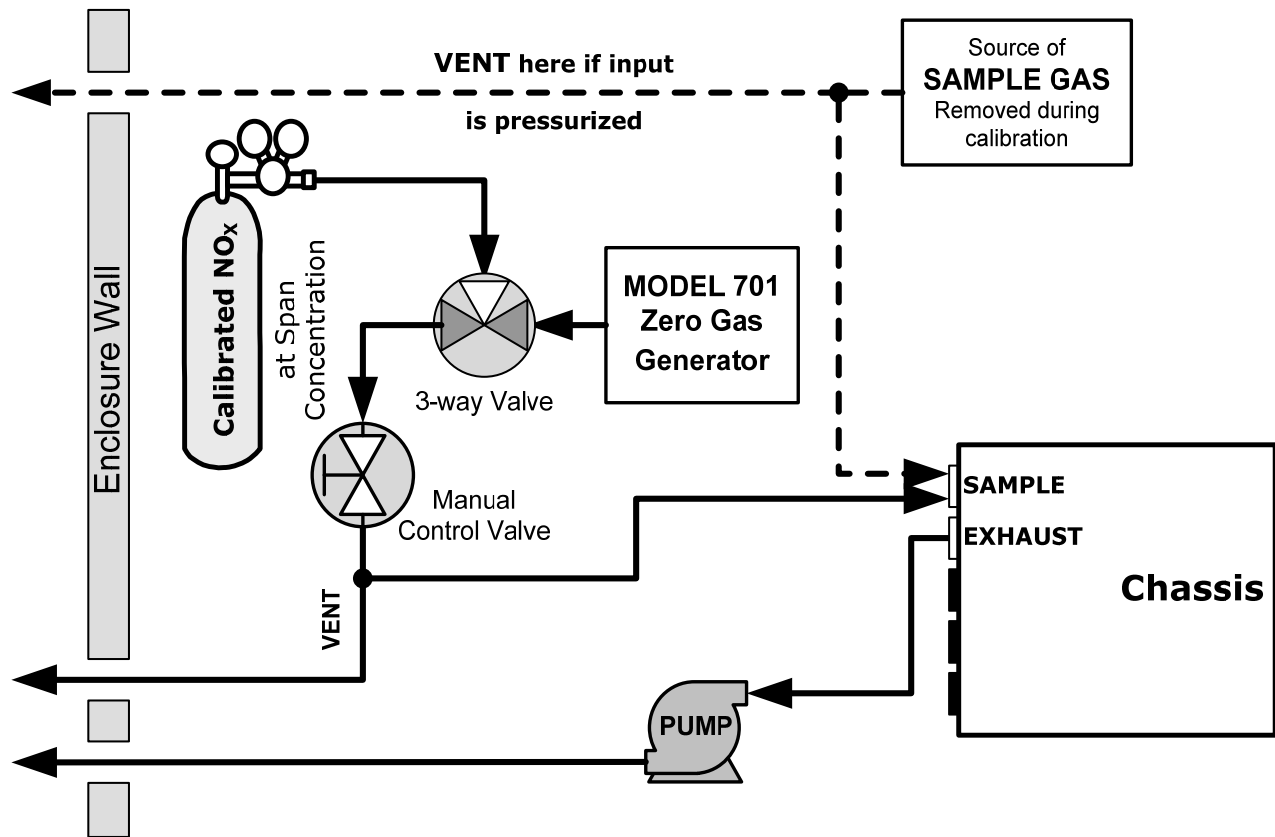

Figure 3-18: Gas Line Connections from Bottled Span Gas – Basic 9110T Configuration

For the 9110T nitrogen oxides analyzer in its basic configuration, attach the following pneumatic lines:

SAMPLE GAS SOURCE

Connect a sample gas line to the SAMPLE inlet

- Use PTFE tubing; minimum OD ¼"
- Sample Gas pressure must equal ambient atmospheric pressure (1.0 psig)
- In applications where the sample gas is received from a pressurized manifold and the analyzer is not equipped with one of the 9110T's pressurized span options, a vent must be placed on the sample gas line. This vent line must be:
 - No more than 10 meters long.
 - Vented outside the shelter or immediate area surrounding the instrument.

CALIBRATION GAS SOURCES

- **CAL GAS & ZERO AIR SOURCES:** The source of calibration gas is also attached to the **SAMPLE** inlet, but only when a calibration operation is actually being performed.
 - Use PTFE tubing; minimum OD ¼".

VENTING

In order to prevent back diffusion and pressure effects, both the span gas and zero air supply lines should be:

- Vented outside the enclosure.
- Minimum OD ¼”.
- Not less than 2 meters in length.
- Not greater than 10 meters in length.

EXHAUST OUTLET

Attach an exhaust line to the EXHAUST outlet fitting. The exhaust line should be:

- Use PTFE tubing; minimum OD ¼”.
- A maximum of 10 meters long.
- Vented outside the 9110T analyzer's enclosure

Note

Once the appropriate pneumatic connections have been made, check all pneumatic fittings for leaks using the procedures defined in Sections 13.3.13.2 (or 13.3.13.3 for detailed check if leak suspected).

PNEUMATIC LAYOUT FOR BASIC CONFIGURATION

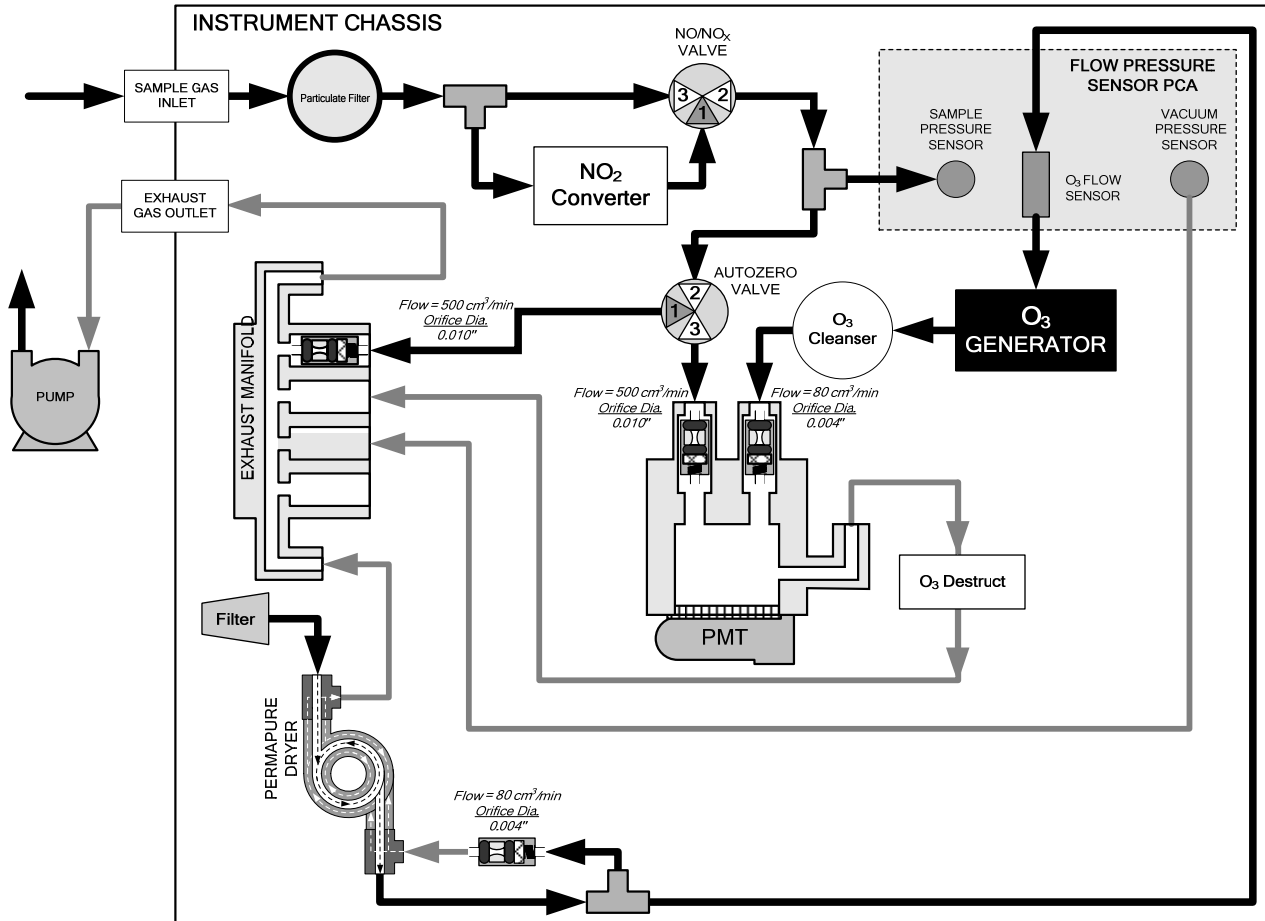

Figure 3-19: Pneumatics, Basic Configuration

3.3.2.3. Connections w/Ambient Zero/Ambient Span (Z/S) Valves (OPT 50A)

This valve package includes:

- Two solenoid valves located inside the analyzer that allow the user to switch either zero, span or sample gas to the instrument's sensor.
- Two additional gas inlet ports (**ZERO AIR** and **SPAN1**).

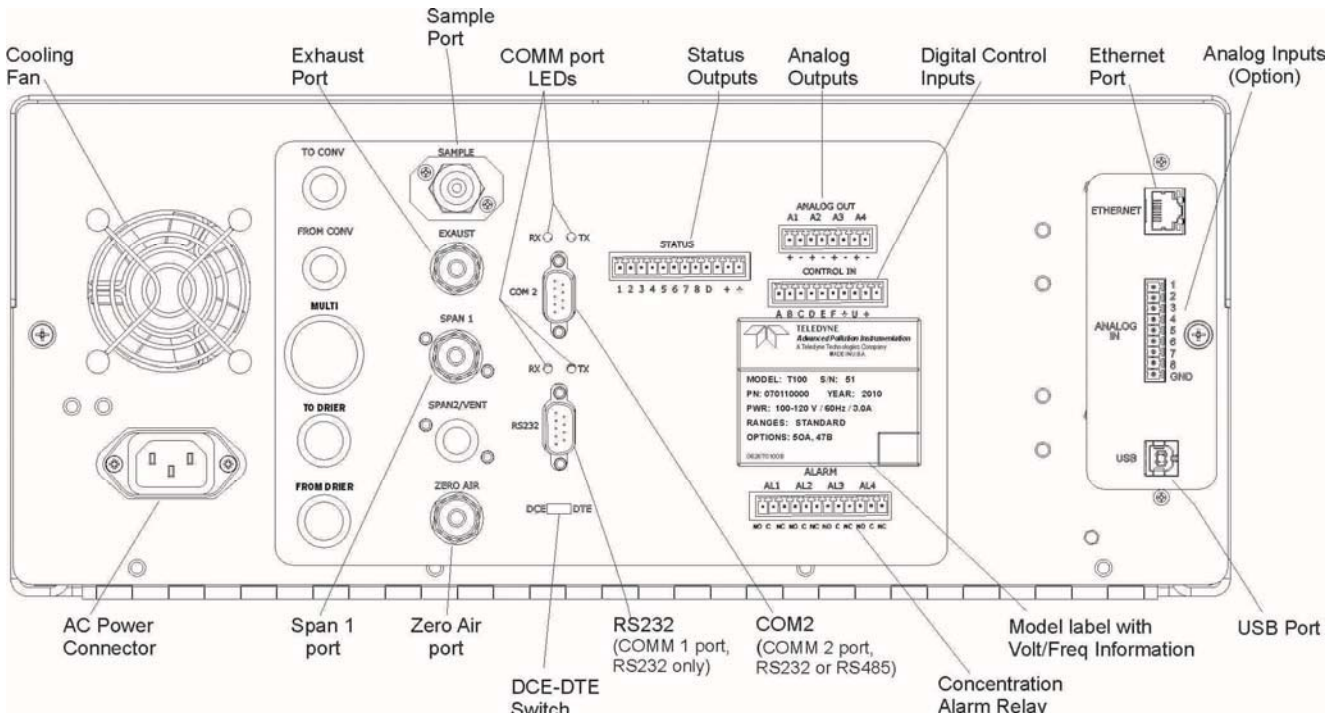

Figure 3-20: Rear Panel Layout with Z/S Valve Options (OPT 50A)

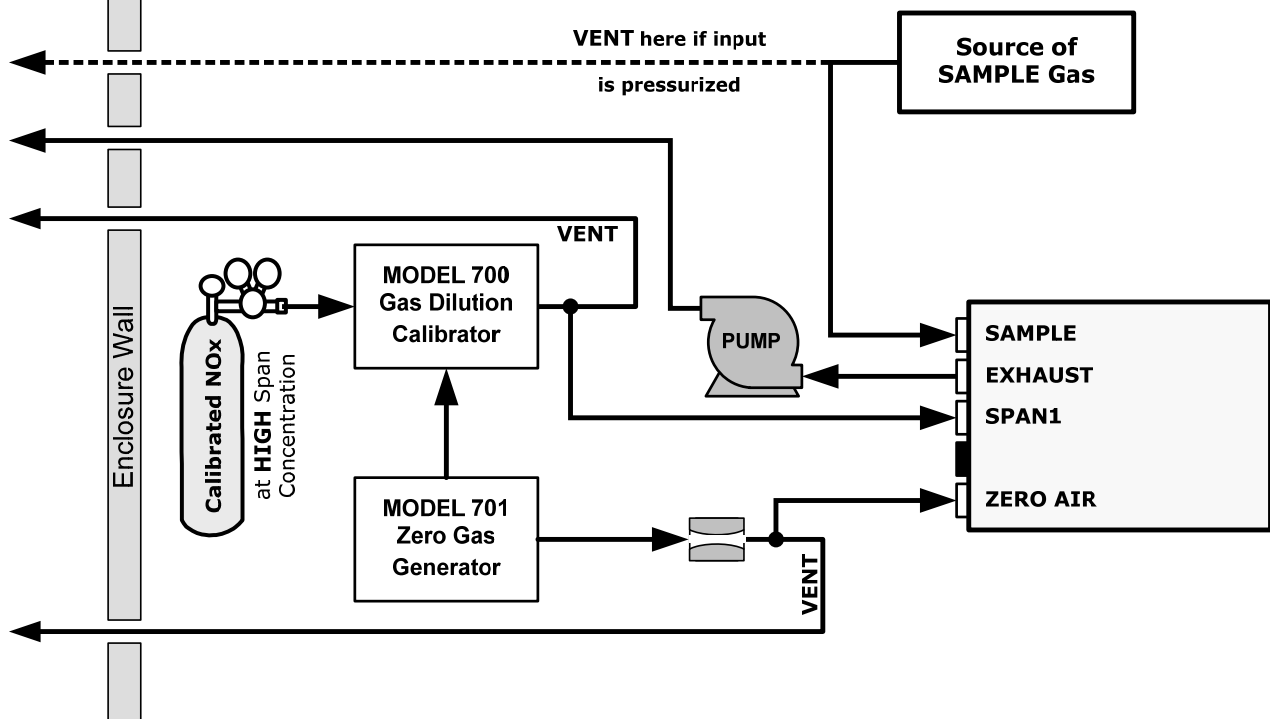

Figure 3-21: Gas Line Connections for 9110T with Z/S Valves Option (OPT 50A)

SAMPLE GAS SOURCE

Attach a sample inlet line to the SAMPLE inlet fitting.

- Use PTFE tubing; minimum O.D 1/4".

- Sample Gas pressure must equal ambient atmospheric pressure (no greater than 1.0 psig).
- In applications where the sample gas is received from a pressurized manifold, a vent must be placed on the sample gas line. This vent line must be no more than 10 meters long.

CALIBRATION GAS SOURCES

- SPAN GAS** Attach a gas line from the source of calibration gas (e.g. a Teledyne M700E Dynamic Dilution Calibrator) to the **SPAN1** inlet (see Figure 3-20). Use PTFE tubing; minimum O.D ¼”.
- ZERO AIR** Zero air is supplied by the zero air generator such as a Teledyne M701. Attach a gas line from the source of zero air to the **ZERO AIR** inlet.

VENTING

In order to prevent back diffusion and pressure effects, both the span gas and zero air supply lines should be:

- Vented outside the enclosure.
- Not less than 2 meters in length.
- Not greater than 10 meters in length.

EXHAUST OUTLET

Attach an exhaust line to the **EXHAUST OUTLET** fitting. The exhaust line should be:

- ¼” PTFE tubing
- maximum 10 meters long
- Vented outside the 9110T analyzer's enclosure

Note

Once the appropriate pneumatic connections have been made, check all pneumatic fittings for leaks using the procedures defined in Section 13.3.12.

To find instructions on calibrating a 9110T with this option installed, see section 10.4.

PNEUMATIC LAYOUT FOR AMBIENT ZERO/AMBIENT SPAN VALVES (OPT 50A)

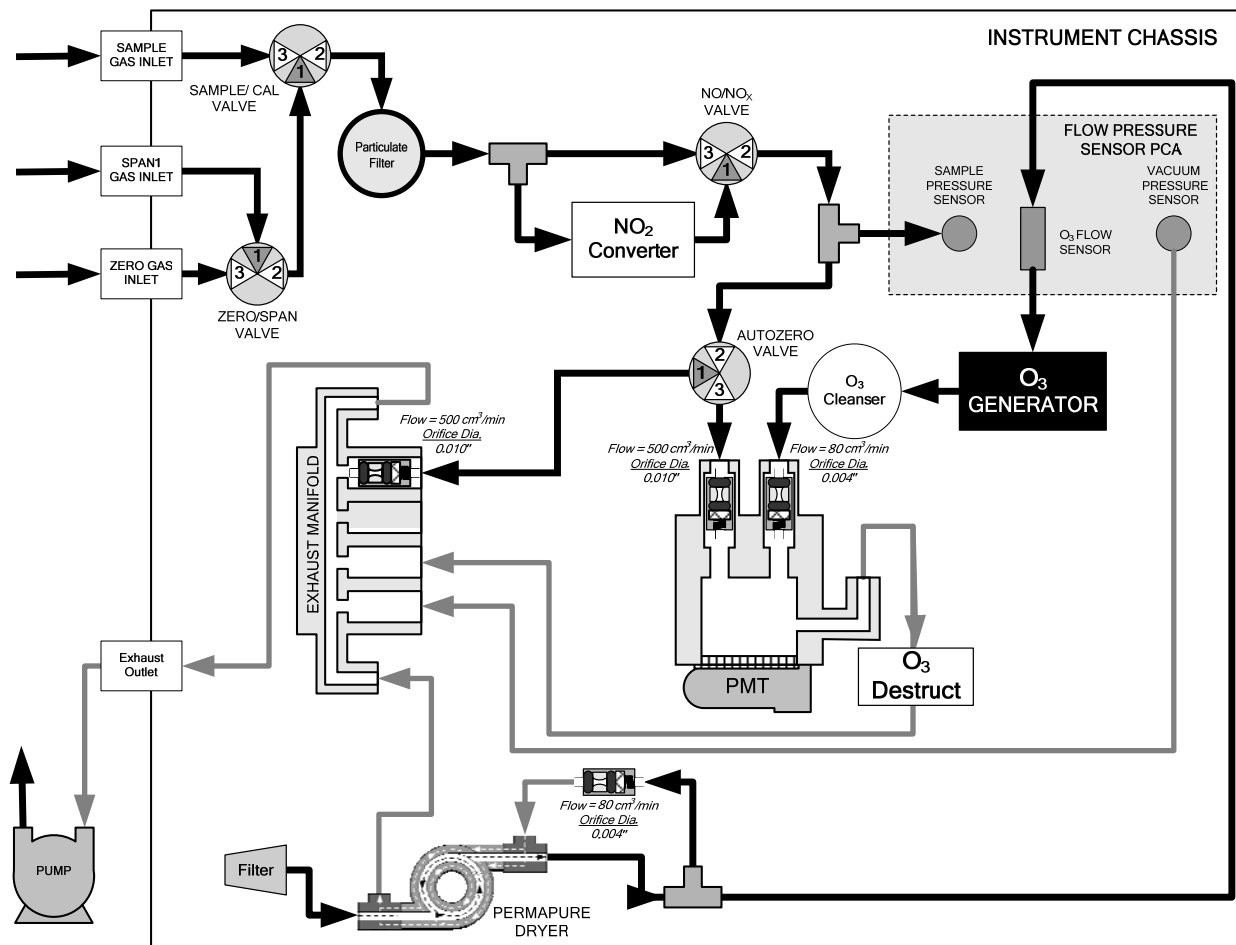

Figure 3-22: Pneumatics with Zero/Span Valves OPT 50A

Table 3-9: Zero/Span Valves Operating States OPT 50A

MODE	VALVE	CONDITION	VALVE PORT STATUS
SAMPLE	Sample/Cal	Open to SAMPLE inlet	3 → 2
	Zero/Span	Open to ZERO AIR inlet	3 → 2
ZERO CAL	Sample/Cal	Open to ZERO/SPAN Valve	1 → 2
	Zero/Span	Open to ZERO AIR inlet	3 → 2
SPAN CAL	Sample/Cal	Open to ZERO/SPAN Valve	1 → 2
	Zero/Span	Open to SPAN inlet	1 → 2

3.3.2.4. Connections w/Ambient Zero/Pressurized Span Valves (OpT 50B)

This calibration valve package is appropriate for applications where Span Gas is being supplied from a pressurized source such as bottled NIST SRM gases. This option includes:

- A critical flow orifice and vent that maintains the Span Gas supply at 1 ATM.
- A SHUTOFF valve to preserve the Span Gas source when it is not in use.
- Two solenoid valves located inside the analyzer that allow the user to switch either zero, span or sample gas to the instrument's sensor.
- Three additional gas inlet ports (**ZERO AIR, SPAN** and **VENT**).

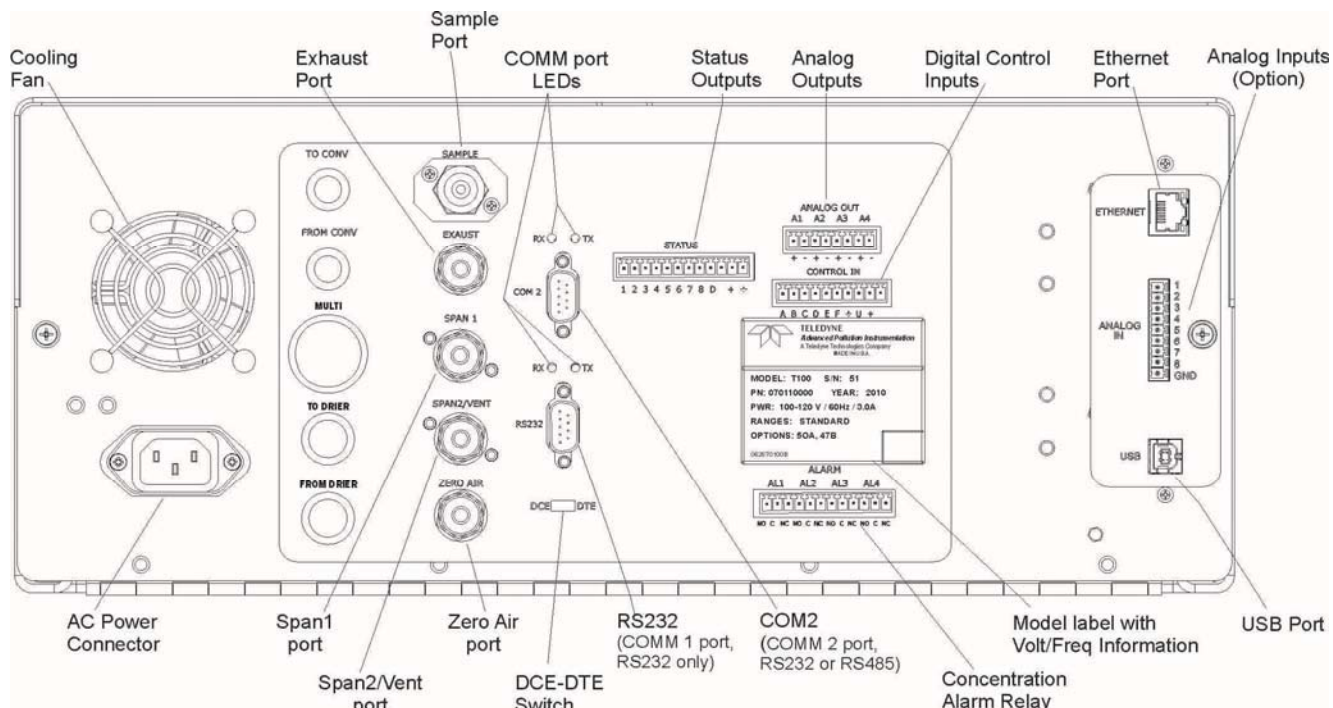

Figure 3-23: Rear Panel Layout with Ambient Zero/Pressurized Span Valves OPT 50B

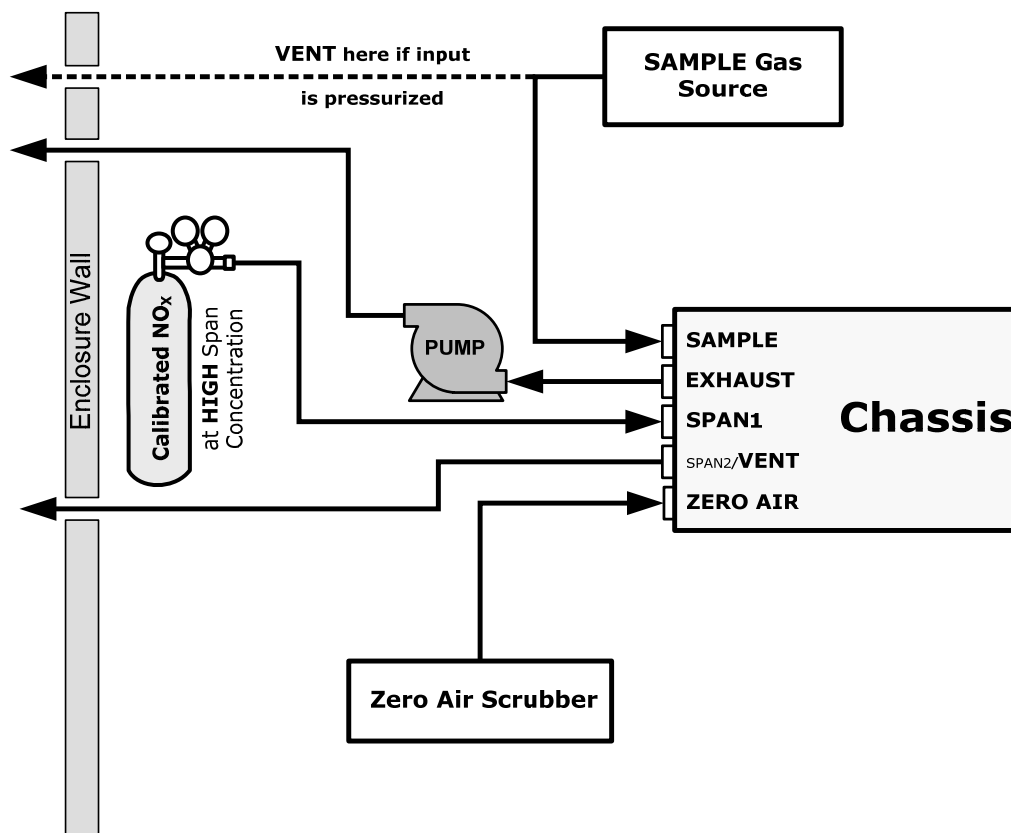

Figure 3-24: Gas Line Connection w/Ambient Zero/Pressurized Span Valves (OPT 50B)

SAMPLE GAS SOURCE

Attach a sample inlet line to the SAMPLE inlet fitting.

- Use PTFE tubing; minimum O.D ¼”.
- Sample Gas pressure must equal ambient atmospheric pressure (29.92 in-Hg).
- In applications where the sample gas is received from a pressurized manifold, a vent must be placed on the sample gas line. This vent line must be:
 - No more than 10 meters long.
 - Vented outside the shelter or immediate area surrounding the instrument.

CALIBRATION GAS SOURCES

SPAN GAS Attach a gas line from the pressurized source of calibration gas (e.g. a bottle of NISTSRM gas) to the SPAN1 inlet.. Use PTFE tubing; minimum O.D ¼”.

ZERO AIR (the dual-stage zero Air Scrubber makes zero air)

VENTING

Attach a line to the SPAN2/VENT outlet. It should be:

- ¼” PTFE tubing.

- Vented outside the enclosure.
- Not less than 2 meters in length.
- Not greater than 10 meters in length.

EXHAUST OUTLET

Attach an exhaust line to the EXHAUST outlet fitting. The exhaust line should be:

- ¼" PTFE tubing.
- A maximum of 10 meters long.
- Vented outside the 9110T analyzer's enclosure.

PNEUMATIC LAYOUT FOR AMBIENT ZERO/PRESSURIZED SPAN (OPT 50B)

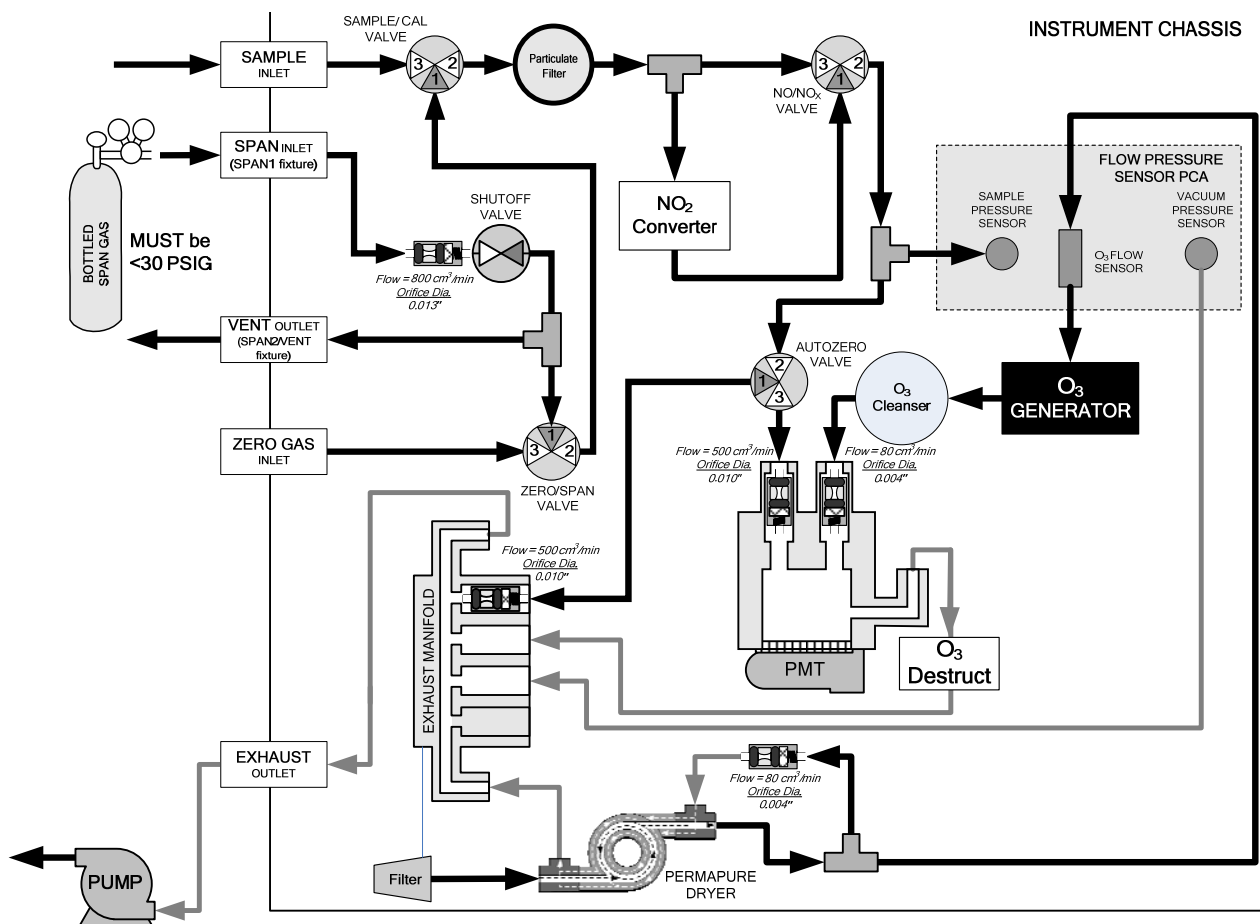

Figure 3-25: Pneumatics with Ambient Zero/Pressurized Span Valves (OPT 50B)

Table 3-10: Valve Operating States OPT 50B installed

MODE	VALVE	CONDITION	VALVE PORT STATUS
SAMPLE	Sample/Cal	Open to SAMPLE inlet	3 → 2
	Zero/Span	Open to ZERO AIR inlet	3 → 2
	Span Shutoff	Closed	
	Zero Air Shutoff	Closed	
ZERO CAL	Sample/Cal	Open to ZERO/SPAN Valve	1 → 2
	Zero/Span	Open to ZERO AIR inlet	3 → 2
	Span Shutoff	OPEN	
	Zero Air Shutoff ¹	Closed	
SPAN CAL	Sample/Cal	Open to ZERO/SPAN Valve	1 → 2
	Zero/Span	Open to SPAN inlet	1 → 2
	Span Shutoff	Closed	
	Zero Air Shutoff	OPEN	

3.3.2.5. Zero Scrubber and Internal Span Source (IZS) (OPT 50G)

The 9110T nitrogen oxides analyzer can also be equipped with an internal NO₂ span gas generator and calibration valve option. This option package is intended for applications where there is a need for frequent automated calibration checks without access to an external source of span gas.

This valve package includes:

- A 2-stage external scrubber for producing zero air.
 - 50% Purafil Chemisorbant[®] (for conversion of NO → NO₂).
 - 50% charcoal (for removal of the NO₂).
- A heated enclosure for a NO₂ permeation tube.
 - This option package DOES NOT contain an actual permeation tube. See Section 1.4 (Options 52B and 52G) for information on specifying the correct permeation tube for each application.
- A special desorber that removes all HNO₃ from the calibration gas stream.
- One additional gas inlet port (**ZERO AIR**).
- One additional gas outlet port (**FROM DRYER**).
- Two internal valves for switching between the sample gas inlet and the output of the zero/span subsystem.

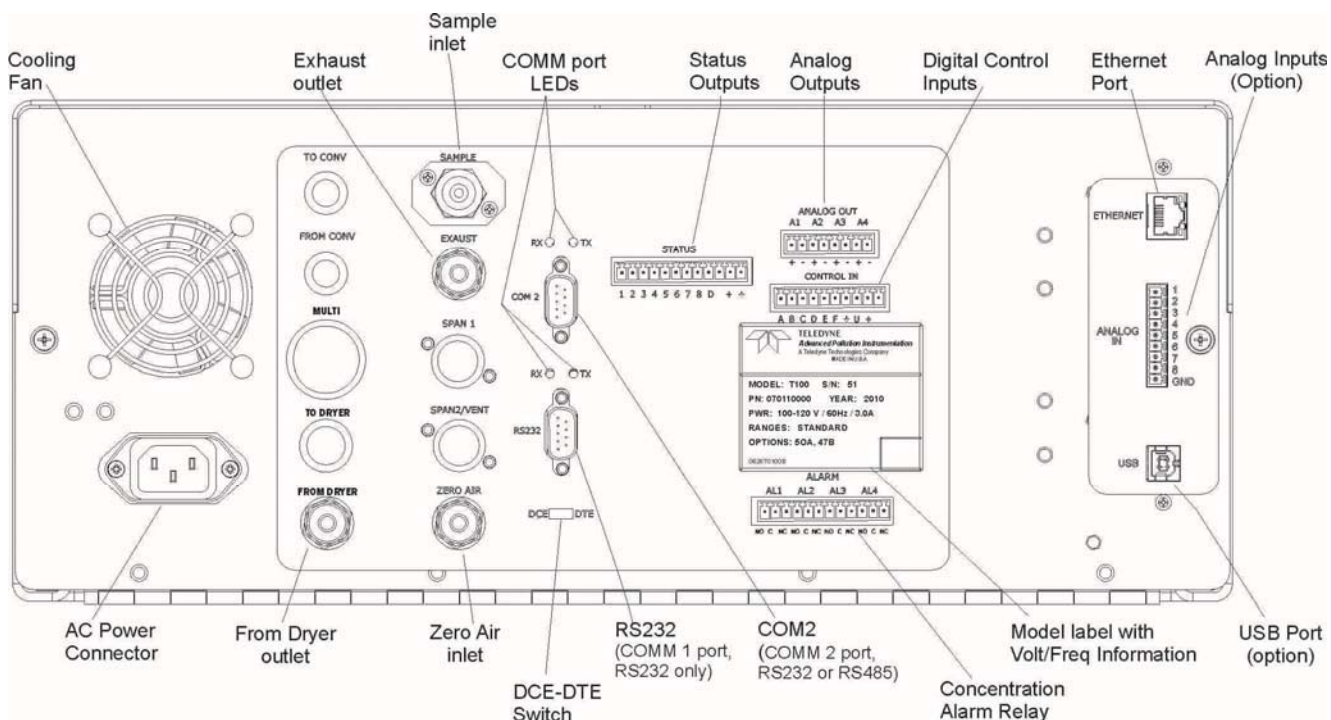

Figure 3-26: Rear Panel Layout with Internal Span Source (IZS) OPT 50G

INTERNAL SPAN GAS GENERATION

The primary component of the internal span option is a permeation tube containing liquid NO₂. As zero air is passed over a permeable membrane on the end of the tube, molecules of NO₂ slowly pass through the membrane mixing with the zero air.

The resulting concentration of the NO₂ span gas is determined by three factors:

- Size of the membrane: The larger the area of the membrane, the more permeation occurs.
- Temperature of the NO₂: Increasing the temperature of the permeation tube increases the pressure inside the tube and therefore increases the rate of permeation.
- Flow rate of the zero air: If the previous two variables are constant, the permeation rate of the NO₂ into the zero air stream will be constant. Therefore, a lower flow rate of zero air produces higher concentrations of NO₂.

In the Model 9110T the permeation tube enclosure is heated to a constant 50° C (10° above the maximum operating temperature of the instrument) in order to keep the permeation rate constant. A thermistor measures the actual temperature and reports it to the CPU for control feedback.

The flow rate of zero air across the permeation tube is maintained at 50 ± 10 cm³/min by a critical flow orifice located in the analyzer’s exhaust manifold.

NITRIC ACID AND THE CHEMISTRY OF NO2 PERMEATION TUBES

The reaction of H₂O with NO₂ to form HNO₃ (nitric acid) takes place whenever water and NO₂ are present in the same gas mixture. In the 9110T this is mitigated as much as possible by passing the air supply for the span gas generator through a special dryer, however the permeable membrane of the NO₂ tube will still allow H₂O from the ambient environment to slowly collect in the tube at increasingly higher concentrations. Over time this results in the presence of HNO₃ in the permeation tube which is exuded into the 9110T’s pneumatics along with NO₂.

HNO₃ is a liquid at room temperature, so once the HNO₃ is released by the permeation tube it condenses and collects along the 9110T's wetted surfaces. While liquid HNO₃ does not directly effect the quality of NO_x measurements of the Model 9110T, it does give off small amounts of gaseous HNO₃ which is converted into NO by the 9110T's NO_x → NO converter resulting in an artificially high NO₂ concentration by 8% to 12%. This is particularly bothersome when 9110T is attempting to measure a zero point, such as during calibration, since the NO₂ concentration will only reach a true zero point once the majority of the HNO₃ coating the wetted surfaces has reverted to NO₂ and this can take a very long time.

The 9110T includes a special HNO₃ desorber which eliminates any HNO₃ given off by the permeation tube before it can be converted into NO by the analyzer's converter.

PNEUMATIC LAYOUT FOR ZERO SCRUBBER AND IZS (OPT 50G)

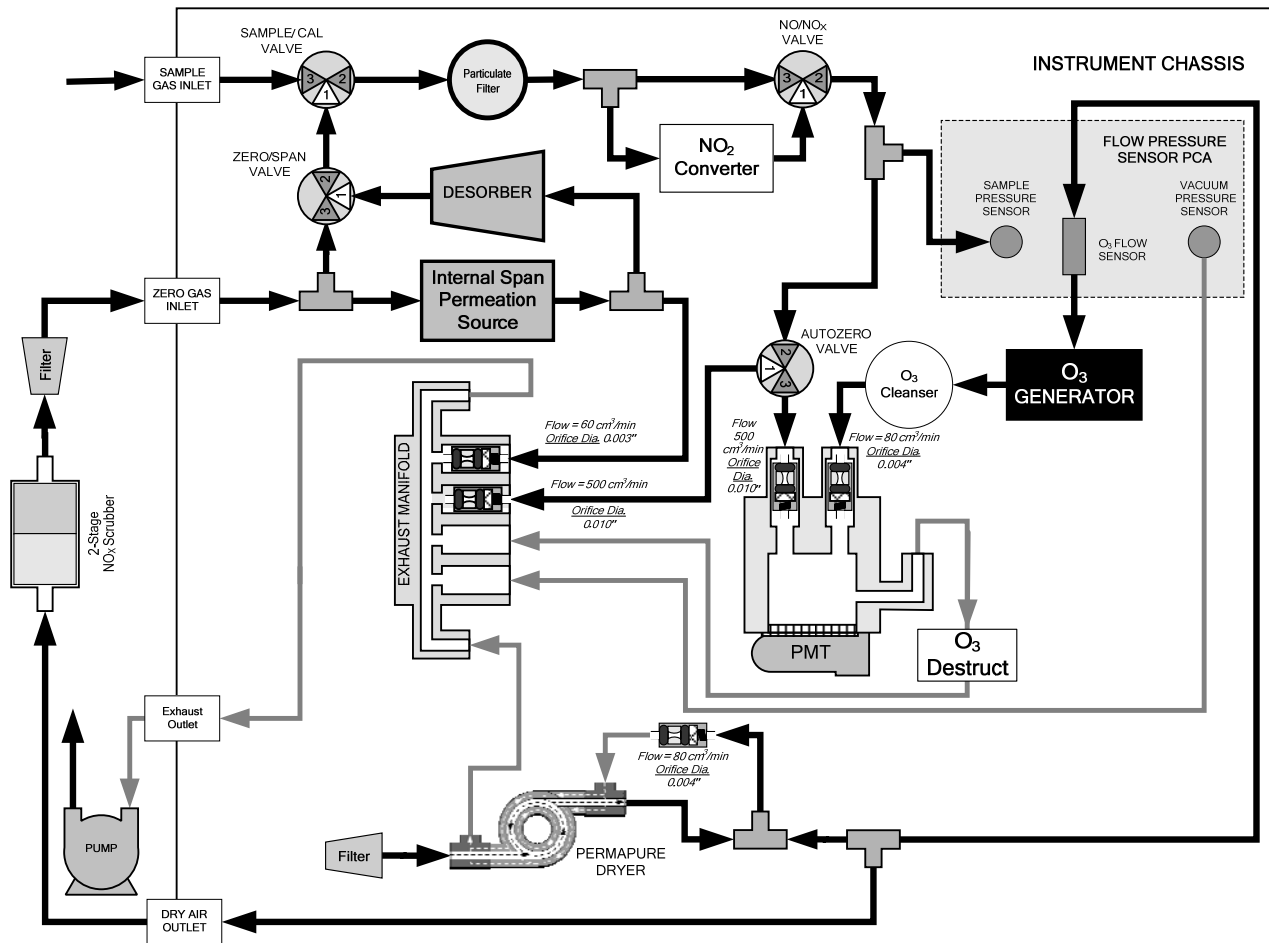

Figure 3-27: Pneumatics with the Internal Span Gas Generator (OPT 50G)

Table 3-11: Internal Span Gas Generator Valve Operating States OPT 50G

MODE	VALVE	CONDITION	VALVE PORT STATUS
SAMPLE	Sample/Cal	Open to SAMPLE inlet	3 → 2

	Zero/Span	Open to ZERO AIR inlet	3 → 2
ZERO CAL	Sample/Cal	Open to ZERO/SPAN Valve	1 → 2
	Zero/Span	Open to ZERO AIR inlet	3 → 2
SPAN CAL	Sample/Cal	Open to ZERO/SPAN Valve	1 → 2
	Zero/Span	Open to SPAN inlet	1 → 2

3.3.2.6. Gas Conditioner Options

AMMONIA REMOVAL SAMPLE DRYER CONDITIONER (OPT 86A)

The 9110T includes a Nafion® permeation gas exchange tube to remove H₂O a from the ozone generator supply gas stream to a dew point of about -20° C (~600 ppm H₂O) and effectively remove concentrations of ammonia (NH₃) up to about 1 ppm.

An additional Sample Conditioner can be added to the 9110T’s sample gas stream.

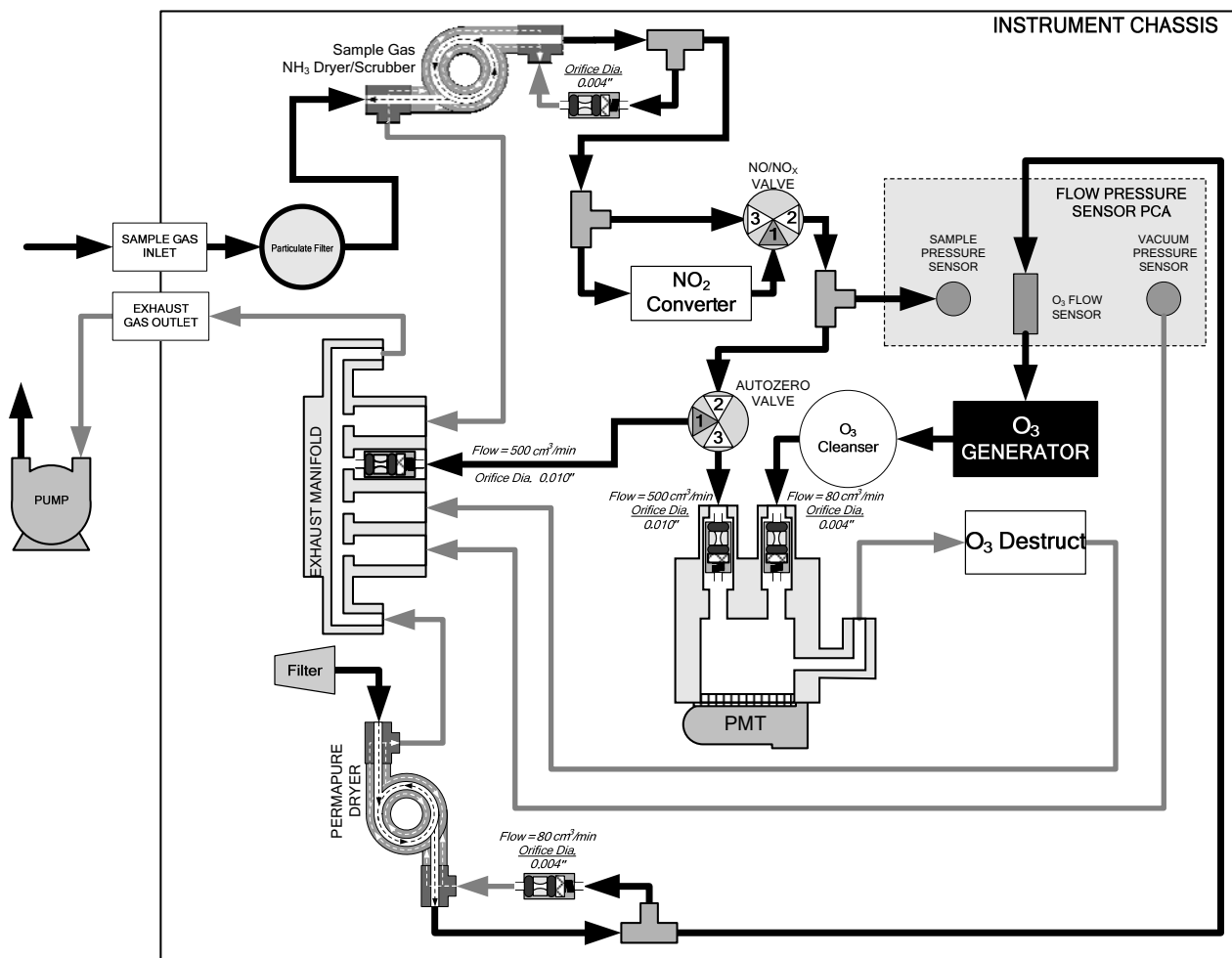

Figure 3-28: Pneumatics for Sample Conditioner OPT 86A

ZERO AIR SCRUBBER (OPT 86C), FOR Z/S VALVES

An external zero air scrubber for Z/S valves can be used in place of a zero air generator. The following pneumatic diagram illustrates the internal and external flow for a 9110T analyzer with a Z/S valve option and the Zero Air Scrubber (Option 86C):

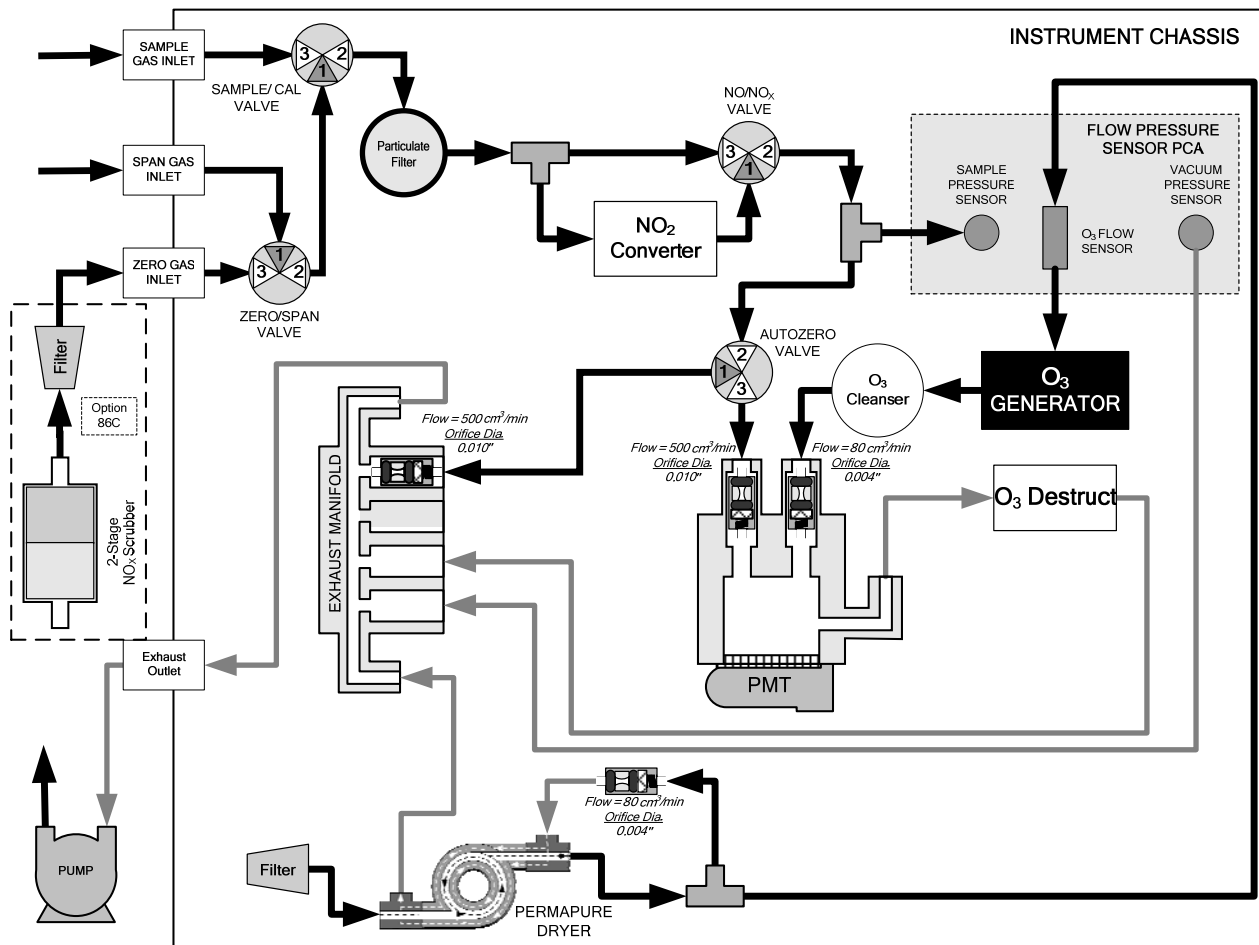

Figure 3-29: Pneumatics for External Zero Air Scrubber (OPT 86C) for Z/S Valves

3.4. STARTUP, FUNCTIONAL CHECKS, AND INITIAL CALIBRATION



CAUTION!

If the presence of ozone is detected at any time, power down the instrument and contact TAI Customer Service as soon as possible:

(626) 934-1500 or email: ask_TAI@teledyne.com

If you are unfamiliar with the 9110T principles of operation, we recommend that you read Section 13. For information on navigating the analyzer's software menus, see the menu trees described in Appendix A.

3.4.1. START UP

After the electrical and pneumatic connections are made, an initial functional check is in order. Turn on the instrument. The pump and exhaust fan should start immediately. The display will show a splash screen and other information during the initialization process while the CPU loads the operating system, the firmware and the configuration data.

The analyzer should automatically switch to Sample Mode after completing the boot-up sequence and start monitoring the gas. However, there is an approximately one hour warm-up period before reliable gas measurements can be taken. During the warm-up period, the front panel display may show messages in the parameters (Param) field.

3.4.2. WARNING MESSAGES

Because internal temperatures and other conditions may be outside the specified limits during the analyzer’s warm-up period, the software will suppress most warning conditions for 30 minutes after power up. If warning messages persist after the 30 minutes warm up period is over, investigate their cause using the troubleshooting guidelines in Section 12.1.

To view and clear warning messages, press:

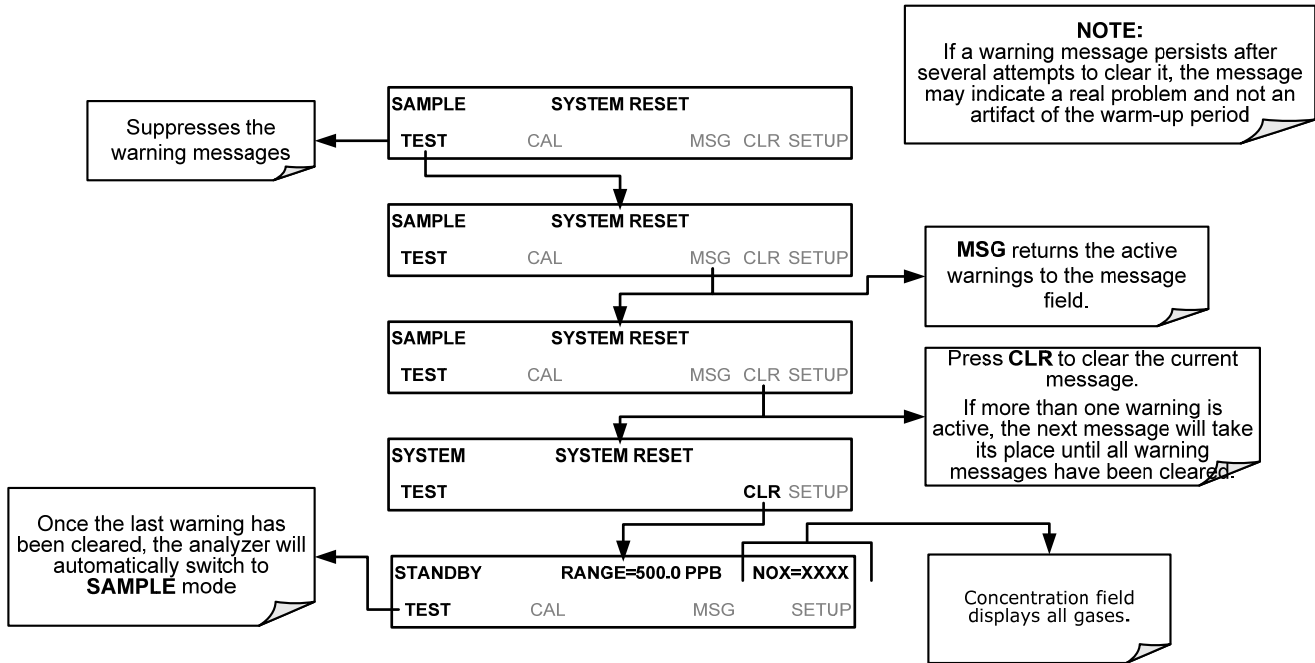

Table 3-12 lists brief descriptions of the warning messages that may occur during start up.

Table 3-12: Possible Warning Messages at Start-Up

MESSAGE	MEANING
SYSTEM RESET¹	The computer has rebooted.
ANALOG CAL WARNING	The A/D or at least one D/A channel have not been calibrated.
BOX TEMP WARNING	The temperature inside the 9110T chassis is outside the specified limits.
CANNOT DYN SPAN²	Contact closure span calibration failed while <i>DYN_SPAN</i> was set to <i>ON</i> .
CANNOT DYN ZERO³	Contact closure zero calibration failed while <i>DYN_ZERO</i> was set to <i>ON</i> .
CONFIG INITIALIZED	Configuration storage was reset to factory configuration or erased.
DATA INITIALIZED	DAS data storage was erased before the last power up occurred.
OZONE FLOW WARNING	Ozone gas flow is too high or too low for accurate NO _x , NO and NO ₂ readings.
OZONE GEN OFF⁴	Ozone generator is off. This is the only warning message that automatically clears itself. It clears itself when the ozone generator is turned on. Upon power up the Ozone generator will remain off for 30 minutes. This allows the perma-pure dryer to reach its working dew point.
RCELL PRESS WARN	Reaction cell pressure is too high or too low for accurate NO _x , NO and NO ₂ readings.
RCELL TEMP WARNING	Reaction cell temperature is too high or too low for accurate NO _x , NO and NO ₂ readings.
IZS TEMP WARNING⁵	IZS temperature is too high or too low for efficient O ₃ production.
CONV TEMP WARNING	NO ₂ to NO Converter temperature too high or too low to efficiently convert NO ₂ to NO.
PMT TEMP WARNING	PMT temperature outside of warning limits specified by <i>PMT_SET</i> variable.
AZERO WARN [XXXX] MV	AutoZero reading too high. The value shown in message indicates auto-zero reading at time warning was displayed.
HVPS WARNING	High voltage power supply output is too high or too low for proper operation of the PMT.
REAR BOARD NOT DET	CPU unable to communicate with motherboard..
RELAY BOARD WARN	CPU is unable to communicate with the relay PCA.
SAMPLE FLOW WARN	The flow rate of the sample gas is outside the specified limits.
¹ Clears 45 minutes after power up. ² Clears the next time successful zero calibration is performed. ³ Clears the next time successful span calibration is performed. ⁴ Clears 30 minutes after power up. ⁵ Only Appears if the IZS option is installed.	

3.4.3. FUNCTIONAL CHECKS

After the analyzer’s components have warmed up for at least 60 minutes, verify that the software properly supports any hardware options that are installed.

For information on navigating through the analyzer’s software menus, see the menu trees described in Appendix A.1.

Check to ensure that the analyzer is functioning within allowable operating parameters.

- Appendix C includes a list of test functions viewable from the analyzer’s front panel as well as their expected values.
- These functions are also useful tools for diagnosing problems with your analyzer.
- The enclosed Final Test and Validation Data sheet (P/N 04409) lists these values before the instrument left the factory.

To view the current values of these parameters press the following button sequence on the analyzer’s front panel. Remember until the unit has completed its warm up these parameters may not have stabilized.

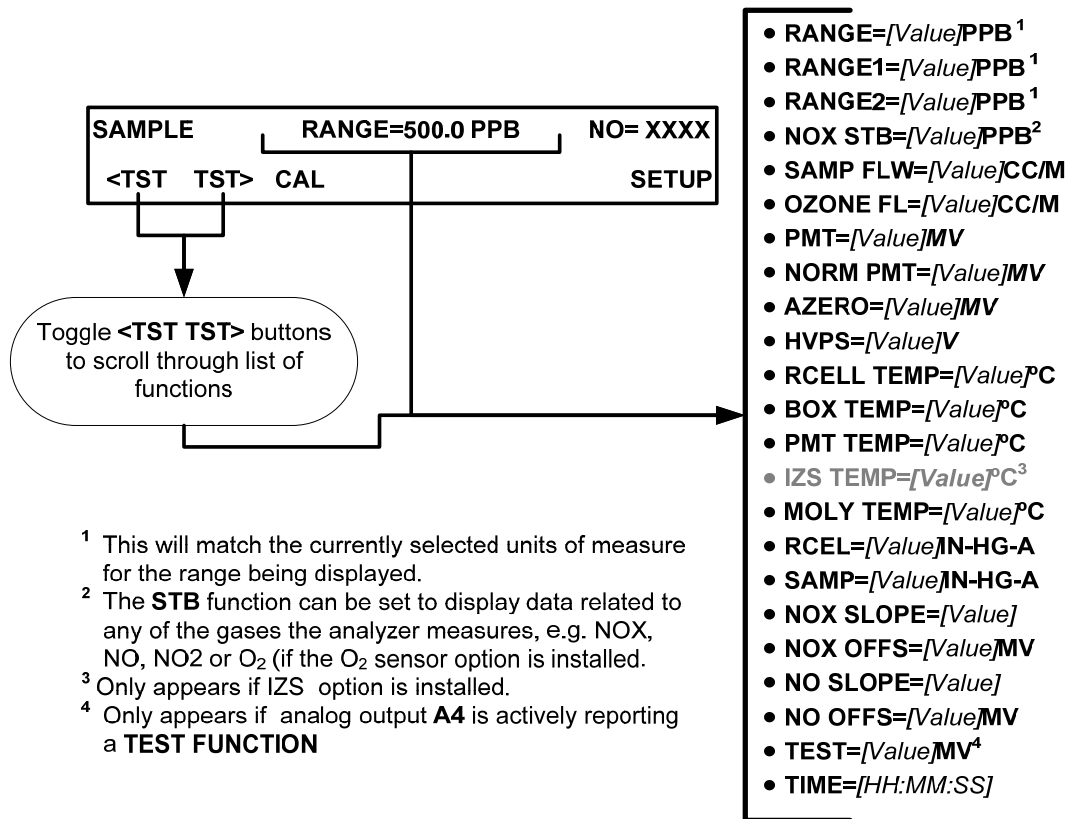

3.4.4. INITIAL CALIBRATION

To perform the following calibration you must have sources for zero air and calibration (span) gas available for input into the inlet/outlet fittings on the back of the analyzer (see Section 3.3.2.1).

Note

A start-up period of 4-5 hours is recommended prior to performing a calibration on the analyzer.

The method for performing an initial calibration for the 9110T nitrogen oxides analyzer differs slightly depending on the whether or not any of the available internal zero air or valve options are installed.

- See Section 3.4.4.2 for instructions for initial calibration of the 9110T analyzers in their base configuration.
- See Section 9.3 for instructions for initial calibration of 9110T analyzers possessing an optional Internal Span Gas Generator (OPT 51A).
- See Section 9.4 for information regarding setup and calibration of 9110T analyzers with Z/S Valve options.
- If you are using the 9110T analyzer for EPA monitoring, only the calibration method described in Section 10 should be used.

3.4.4.1. INTERFERENTS FOR NO_x, NO AND NO₂ MEASUREMENTS

The chemiluminescence method for detecting NO_x is subject to interference from a number of sources including water vapor (H₂O), ammonia (NH₃), sulfur dioxide (SO₂) and carbon dioxide (CO₂) but the 9110T has been designed to reject most of these interferences.

- Ammonia is the most common interferent, which is converted to NO in the analyzer's NO₂ converter and creates a NO_x signal artifact.
 - If the 9110T is installed in an environment with high ammonia, steps should be taken to remove the interferent from the sample gas before it enters the reaction cell.
 - TAI offers a sample gas conditioning option to remove ammonia and water vapor (Section 3.3.2.6).
- Carbon dioxide (CO₂) diminishes the NO_x signal when present in high concentrations.
 - If the analyzer is used in an application with excess CO₂, contact TAI's Customer Service Department (see Section 12.10) for possible solutions.
- Excess water vapor can be removed with one of the dryer options described in Section 3.3.2.6. In ambient air applications, SO₂ interference is usually negligible.

For more detailed information regarding interferents for NO_x, NO and NO₂ measurement, see Section 13.1.5.

3.4.4.2. Initial Calibration Procedure for 9110T Analyzers without Options

The following procedure assumes that:

- The instrument DOES NOT have any of the available calibration valve or gas inlet options installed;

- Cal gas will be supplied through the SAMPLE gas inlet on the back of the analyzer and;
- The pneumatic setup matches that described in Section 3.3.2.

VERIFYING THE REPORTING RANGE SETTINGS

While it is possible to perform the following procedure with any range setting we recommend that you perform this initial checkout using following reporting range settings:

- Unit of Measure: PPB
- Reporting Range: 500 ppb
- Mode Setting: SNGL

While these are the default setting for the 9110T analyzer, it is recommended that you verify them before proceeding with the calibration procedure, by pressing the following menu button sequence:

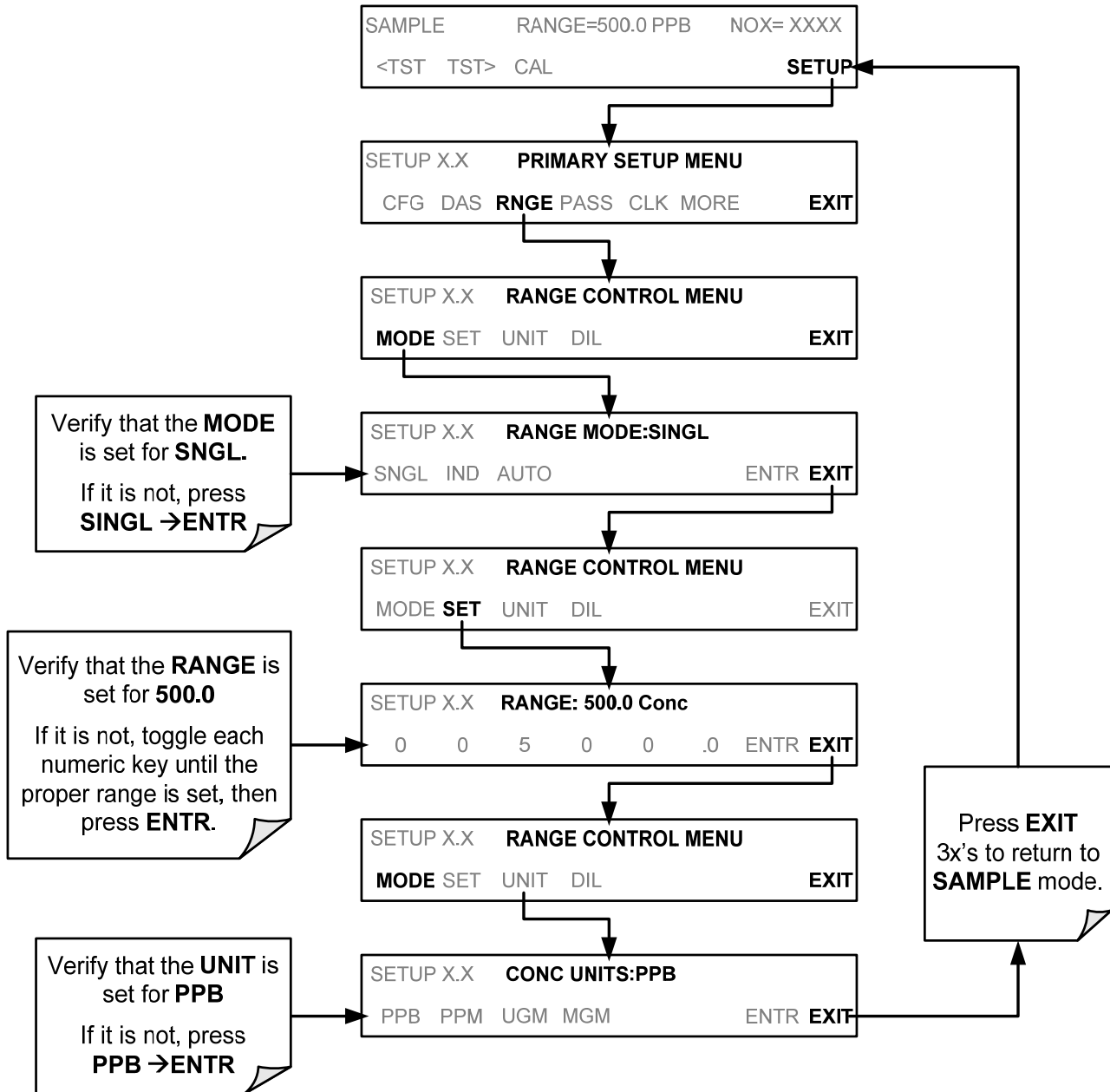

VERIFYING THE EXPECTED NO_x AND NO SPAN GAS CONCENTRATION

IMPORTANT

IMPACT ON READINGS OR DATA

Verify the **PRECISE** Concentration Value of the **SPAN** gases independently.

If you supply **NO** gas to the analyzer, the values for expected **NO** and **NO_x** **MUST** be identical.

The NO_x and NO span concentration values automatically defaults to **400.0 PPB** and it is recommended that calibration gases of that concentration be used for the initial calibration of the unit.

To verify that the analyzer span setting is set for **400 PPB**, press:

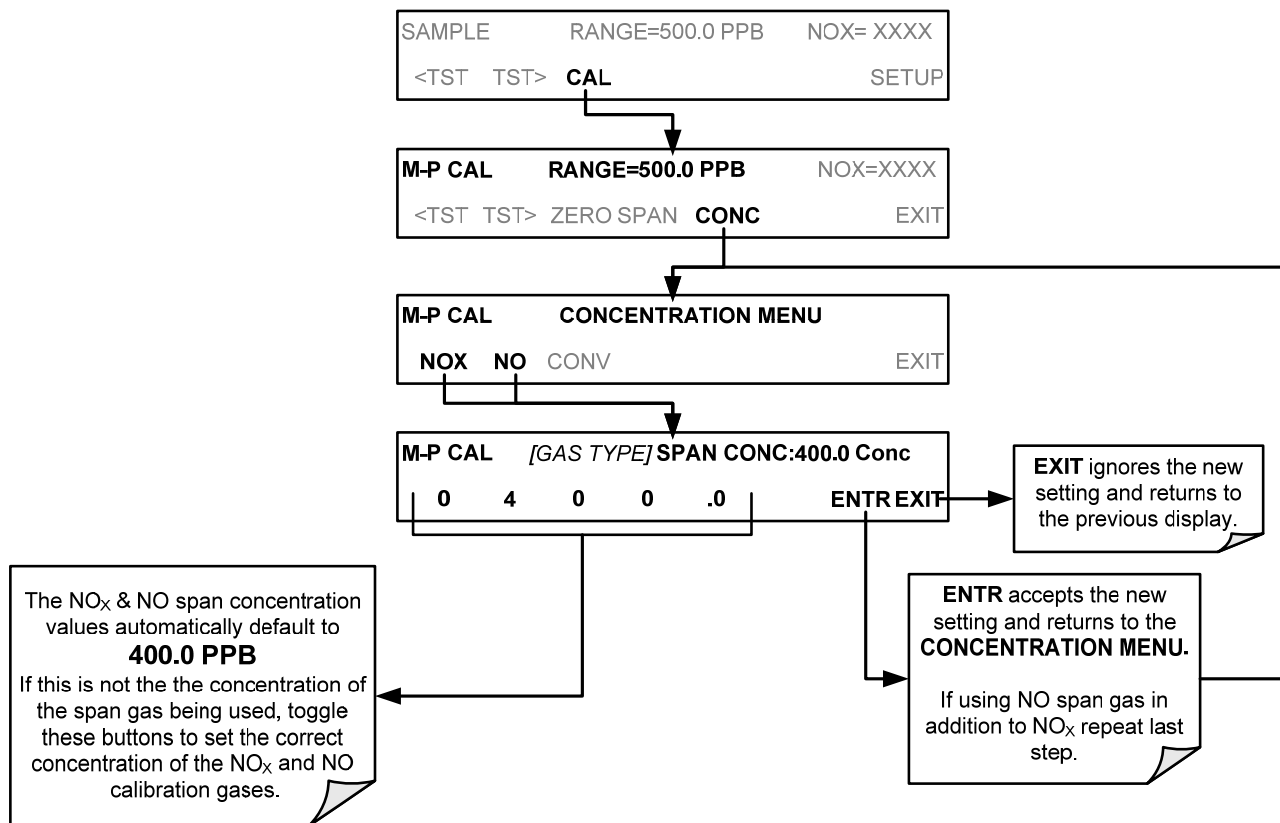

INITIAL ZERO/SPAN CALIBRATION PROCEDURE

To perform an initial Calibration of the 9110T nitrogen oxides analyzer, press:

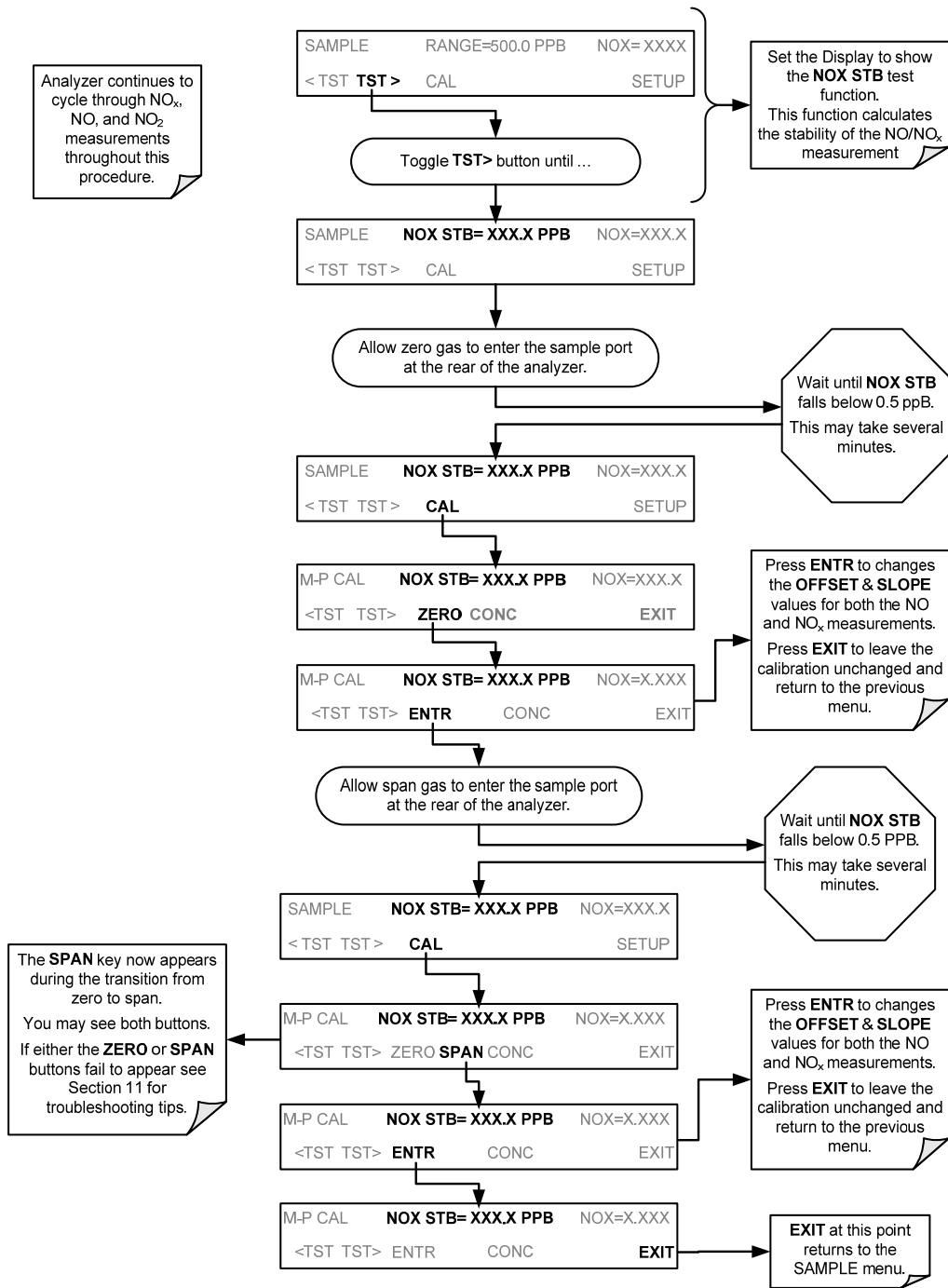

The 9110T Analyzer is now ready for operation.

Note

Once you have completed the above set-up procedures, please fill out the Quality Questionnaire that was shipped with your unit and return it to Teledyne. This information is vital to our efforts in continuously improving our service and our products. THANK YOU.

PART II
—
OPERATING INSTRUCTIONS

This page intentionally left blank.

4. OVERVIEW OF OPERATING MODES

To assist in navigating the analyzer's software, a series of menu trees is available for reference in Appendix A of this manual.

Note

Some control buttons on the touch screen do not appear if they are not applicable to the menu that you're in, the task that you are performing, the command you are attempting to send, or to incorrect settings input by the user. For example, the ENTR button may disappear if you input a setting that is invalid or out of the allowable range for that parameter, such as trying to set the 24-hour clock to 25:00:00. Once you adjust the setting to an allowable value, the ENTR button will re-appear.

The 9110T analyzer software has a variety of operating modes. The most common mode that the analyzer will be operating in is the **SAMPLE** mode. In this mode, a continuous read-out of the NO_x concentrations can be viewed on the front panel and output as an analog voltage from rear panel terminals.

The second most important operating mode is **SETUP** mode. This mode is used for configuring the various sub systems of the analyzer such as for the DAS system, the reporting ranges, or the serial (RS-232 / RS-485 / Ethernet) communication channels. The **SETUP** mode is also used for performing various diagnostic tests during troubleshooting.



Figure 4-1: Front Panel Display

The mode field of the front panel display indicates to the user which operating mode the unit is currently running.

In addition to **SAMPLE** and **SETUP**, other modes the analyzer can be operated in are described in Table 7-1 below.

Table 4-1: Analyzer Operating Modes

MODE	EXPLANATION
DIAG	One of the analyzer's diagnostic modes is active.
LO CAL A	Unit is performing LOW SPAN (midpoint) calibration initiated automatically by the analyzer's AUTOCAL feature
LO CAL R	Unit is performing LOW SPAN (midpoint) calibration initiated remotely through the COM ports or digital control inputs.
M-P CAL	This is the basic calibration mode of the instrument and is activated by pressing the CAL button.
SAMPLE	Sampling normally, flashing text indicates adaptive filter is on.
SAMPLE A	Indicates that unit is in SAMPLE mode and AUTOCAL feature is activated.
SETUP X.#²	SETUP mode is being used to configure the analyzer. The gas measurement will continue during setup.
SPAN CAL A¹	Unit is performing SPAN calibration initiated automatically by the analyzer's AUTOCAL feature
SPAN CAL M¹	Unit is performing SPAN calibration initiated manually by the user.
SPAN CAL R¹	Unit is performing SPAN calibration initiated remotely through the COM ports or digital control inputs.
ZERO CAL A¹	Unit is performing ZERO calibration procedure initiated automatically by the AUTOCAL feature
ZERO CAL M¹	Unit is performing ZERO calibration procedure initiated manually by the user.
ZERO CAL R¹	Unit is performing ZERO calibration procedure initiated remotely through the COM ports or digital control inputs.

¹ Only Appears on units with Z/S valve or IZS options.
² The revision of the analyzer firmware is displayed following the word SETUP, e.g., SETUP G.3.

4.1. SAMPLE MODE

This is the analyzer's standard operating mode. In this mode, the instrument is calculating NO_x, NO and NO₂ concentrations. These values are displayed in the **CONC** field of the analyzer's front panel display. While the instrument is in **SAMPLE** mode, this field provides a readout of all the gas concentrations being measured by the 9110T: NO_x, NO and NO₂.

When the analyzer is in sample mode the **PARAM** field will display warning messages and test functions that give the user information about the operational status of the analyzer.

4.1.1. TEST FUNCTIONS

A variety of **TEST** functions are available for viewing at the front panel whenever the analyzer is at the **MAIN MENU**. These functions provide information about the various functional parameters related to the analyzer's operation and its measurement of gas concentrations. This information is particularly when troubleshooting a performance problem with the 9110T (see Section 13). Figure 4-2 will display the Test Functions on the front panel screen. Table 4-2 lists the available **TEST** functions.

Table 4-2: Test Functions Defined

DISPLAY	PARAMETER	UNITS	DESCRIPTION
RANGE	RANGE	PPB, PPM, UGM &	The Full Scale limit at which the reporting range of the analyzer's ANALOG OUTPUTS is currently set. THIS IS NOT the Physical Range of the instrument. See Section 5.4.1 for more information.

DISPLAY	PARAMETER	UNITS	DESCRIPTION
RANGE1 RANGE2		MGM	If AUTO Range mode has been selected, two RANGE functions will appear, one for each range: <ul style="list-style-type: none"> • RANGE1: The range setting for all analog outputs. • RANGE2: The HIGH range setting for all analog outputs.
RANGE1 RANGE2 RANGE3			If the IND Range mode has been selected, three RANGE functions will appear, one for each range: <ul style="list-style-type: none"> • RANGE1: NO_x concentration output un A1. • RANGE2: NO concentration output un A2. • RANGE2: NO₂ concentration output un A3.
NOX STB	STABILITY	PPB	The standard deviation of concentration readings of the selected gas. <ul style="list-style-type: none"> • Data points are recorded every ten seconds. The calculation uses the last 25 data points.
SAMP FLW	SAMPFLOW	CC/M	Gas flow rate of the sample gas into the reaction cell.
OZONE FL	OZONEFLOW	CC/M	Gas flow rate of O ₃ gas into the reaction cell.
PMT	PMT	MV	The raw signal output of the PMT.
NORM PMT	NORMPMT	MV	The signal output of the PMT after is has been normalized for temperature, pressure, auto-zero offset, but not range.
AZERO	AUTOZERO	MV	The PMT signal with zero NO _x , which is usually slightly different from 0 V. This offset is subtracted from the PMT signal and adjusts for variations in the zero signal.
HVPS	HVPS	V	The output power level of the high voltage power supply.
RCELL TEMP	RCELLTEMP	C	The temperature of the gas inside the reaction cell temperature.
BOX TEMP	BOXTEMP	C	The temperature inside the analyzer chassis.
PMT TEMP	PMTTEMP	C	The temperature of the PMT .
IZS TEMP ¹	IZSTEMP	C	The temperature of the internal span gas generator's permeation tube.
MOLY TEMP	CONVTEMP	C	The temperature of the analyzer's NO ₂ → NO converter.
RCEL	RCELLPRESS	IN-HG-A	The current pressure of the sample gas in the reaction cell as measured at the vacuum manifold.
SAMP	SAMPPRESS	IN-HG-A	The current pressure of the sample gas as it enters the reaction cell, measured between the NO/NO _x and Auto-Zero valves.
NOX SLOPE	NOXSLOPE		The slope calculated during the most recent NO _x zero/span calibration.
NOX OFFS	NOXOFFSET	MV	The offset calculated during the most recent NO _x zero/span calibration.
NO SLOPE	NOSLOPE		The slope calculated during the most recent NO zero/span calibration.
NO OFFS	NOOFFSET	MV	The offset calculated during the most recent NO zero/span calibration.
TEST	TESTCHAN	MV	Displays the signal level of the Test Function that is currently being produced by the Analog Output Channel A4 .
TIME	CLOCKTIME	HH:MM:SS	The current time. This is used to create a time stamp on DAS readings, and by the AutoCal feature to trigger calibration events.

¹Only appears if Internal Span Gas Generator option is installed.

To view these **TEST** functions, press,

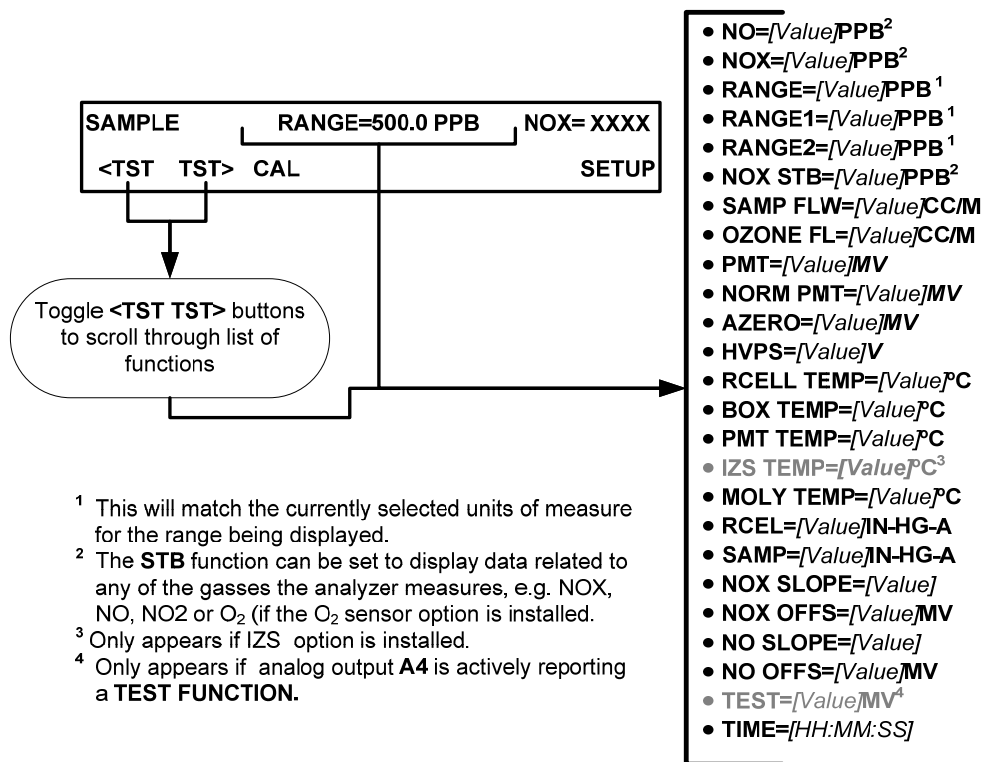

Figure 4-2: Viewing 9110T Test Functions

IMPORTANT

IMPACT ON READINGS OR DATA

A value of “XXXX” displayed for any of the TEST functions indicates an out-of-range reading or the analyzer’s inability to calculate it. All pressure measurements are represented in terms of absolute pressure. Absolute, atmospheric pressure is 29.92 in-Hg-A at sea level. It decreases about 1 in-Hg per 300 m gain in altitude. A variety of factors such as air conditioning and passing storms can cause changes in the absolute atmospheric pressure.

4.1.2. WARNING MESSAGES

The most common and serious instrument failures will activate Warning Messages that are displayed on the analyzer's Front Panel. They are listed on Table 4-3 as follows:

Table 4-3: Warning Messages Defined

MESSAGE	MEANING
ANALOG CAL WARNING	The A/D or at least one D/A channel has not been calibrated.
AZERO WARN	Auto-zero reading above limit specified by <i>AZERO_LIMIT</i> variable. Value shown in message indicates auto-zero reading at time warning was displayed.
BOX TEMP WARNING	The temperature inside the 9110T chassis is outside the specified limits.
CANNOT DYN SPAN	Contact closure span calibration failed while <i>DYN_SPAN</i> was set to <i>ON</i> .
CANNOT DYN ZERO	Contact closure zero calibration failed while <i>DYN_ZERO</i> was set to <i>ON</i> .
CONFIG INITIALIZED	Configuration storage was reset to factory configuration or erased.
CONV TEMP WARNING	NO ₂ → NO converter temperature outside of warning limits specified by <i>CONV_SET</i> variable.
DATA INITIALIZED	DAS data storage was erased before the last power up occurred.
HVPS WARNING	High voltage power supply output outside of warning limits specified by <i>HVPS_SET</i> variable.
IZS TEMP WARNING ¹	IZS temperature outside of warning limits specified by <i>IZS_SET</i> variable.
OZONE FLOW WARNING	Ozone flow outside of warning limits specified by <i>OFLOW_SET</i> variable.
OZONE GEN OFF	Ozone generator is off. This warning message clears itself when the ozone generator is turned on.
PMT TEMP WARNING	PMT temperature outside of warning limits specified by <i>PMT_SET</i> variable.
RCELL PRESS WARN	Reaction cell pressure outside of warning limits specified by <i>RCELL_PRESS_SET</i> variable.
RCELL TEMP WARNING	Reaction cell temperature outside of warning limits specified by <i>RCELL_SET</i> variable.
REAR BOARD NOT DET	Motherboard was not detected during power up.
RELAY BOARD WARN	CPU is unable to communicate with the relay PCA.
SAMPLE FLOW WARN	The flow rate of the sample gas is outside the specified limits.
SYSTEM RESET	The computer has rebooted.
¹ Only Appears if the Internal Span Gas Generator option is installed.	

4.2. CALIBRATION MODE

Pressing the CAL button, switches the analyzer into calibration mode. In this mode the user can, in conjunction with introducing zero or span gases of known concentrations into the analyzer, cause it to adjust and recalculate the slope (gain) and offset of the its measurement range. This mode is also used to check the current calibration status of the instrument.

If the instrument includes one of the available zero/span valve options, the **SAMPLE** mode display will also include **CALZ** and **CALS** buttons. Pressing either of these buttons also puts the instrument into calibration mode.

- The **CALZ** button is used to initiate a calibration of the analyzer's zero point using internally generated zero air.
- The **CALS** button is used to calibrate the span point of the analyzer's current reporting range using span gas.

Note

It is recommended that this span calibration be performed at 80% of full scale of the analyzer's currently selected reporting range.

EXAMPLES:

If the reporting range is set for 0 to 500 ppb, an appropriate span point would be 400 ppb.

If the of the reporting range is set for 0 to 1000 ppb, an appropriate span point would be 800 ppb.

Due to the critical importance and complexity, calibration operations are described in detail in other sections of the manual:

- Section 9 details setting up and performing standard calibration operations or checks.
- Section 10 details setting up and performing EPA protocol calibrations.

For information on using the automatic calibrations feature (**ACAL**) in conjunction with the one of the calibration valve options, see Sections 9.4.3 and 9.5.

IMPORTANT

IMPACT ON READINGS OR DATA

To avoid inadvertent adjustments to critical settings, activate calibration security by enabling password protection in the SETUP – PASS menu (Section 5.5).

4.3. SETUP MODE

The SETUP Mode contains a variety of choices that are used to configure the analyzer's hardware and software features, perform diagnostic procedures, gather information on the instruments performance and configure or access data from the internal data acquisition system (DAS). For a visual representation of the software menu trees, refer to Appendix A.

SETUP Mode is divided between Primary and Secondary Setup menus and can be protected through password security.

4.3.1. PASSWORD SECURITY

SETUP Mode can be protected by password security through the SETUP>PASS menu (Section 5.5) to prevent unauthorized or inadvertent configuration adjustments.

4.3.2. PRIMARY SETUP MENU

The areas accessed and configured under the primary SETUP Mode menu are shown in Table 4-4.

Table 4-4: Primary Setup Mode Features and Functions

MODE OR FEATURE	CONTROL BUTTON LABEL	DESCRIPTION	MANUAL SECTION
Analyzer Configuration	CFG	Lists button hardware and software configuration information.	5.1
<i>Auto Cal Feature</i>	ACAL	Used to set up and operate the AutoCal feature. <ul style="list-style-type: none"> Only appears if the analyzer has one of the calibration valve options installed. 	5.2, 9.5
Internal Data Acquisition (DAS)	DAS	Used to set up the DAS system and view recorded data.	7
Analog Output Reporting Range Configuration	RNGE	Used to configure the output signals generated by the instruments analog outputs.	5.4
Calibration Password Security	PASS	Turns the calibration password feature ON/OFF.	5.5
Internal Clock Configuration	CLK	Used to set or adjust the instrument's internal clock.	5.6
Secondary SETUP Mode (Advanced SETUP features)	MORE	This button accesses the instruments secondary setup menu.	See Table 4-5

4.3.3. SECONDARY SETUP MENU (SETUP →MORE)

The areas accessed and configured under the secondary SETUP Mode menu are shown in Table 4-5.

Table 4-5: Secondary Setup Mode Features and Functions

MODE OR FEATURE	CONTROL BUTTON LABEL	DESCRIPTION	MANUAL SECTION
External Communication Channel Configuration	COMM	Used to set up and operate the analyzer's various external I/O channels including RS-232; RS-485, modem communication and/or Ethernet access.	8
System Status Variables	VARs	Used to view various variables related to the instruments current operational status. <ul style="list-style-type: none"> Changes made to any variable are not acknowledged and recorded in the instrument's memory until the ENTR button is pressed. Pressing the EXIT button ignores the new setting. If the EXIT button is pressed before the ENTR button, the analyzer will beep alerting the user that the newly entered value has been lost. 	5.8
System Diagnostic Features and Analog Output Configuration	DIAG	Used to access a variety of functions that are used to configure, test or diagnose problems with a variety of the analyzer's basic systems. Most notably, the menus used to configure the output signals generated by the instruments' analog outputs are located here.	5.9, 5.9.2

IMPORTANT

IMPACT ON READINGS OR DATA

Any changes made to a variable during the SETUP procedures are not acknowledged by the instrument until the ENTR button is pressed. If the EXIT button is pressed before the ENTR button, the analyzer will make an audible signal before exiting the menu, alerting the user that the newly entered value had not been accepted.

5. SETUP MENU

The SETUP Mode menu is used to set instrument parameters for performing configuration, calibration, reporting and diagnostics operations according to user needs.

5.1. SETUP → CFG: CONFIGURATION INFORMATION

Pressing the CFG button displays the instrument configuration information. This display lists the analyzer model, serial number, firmware revision, software library revision, CPU type and other information. Use this information to identify the software and hardware when contacting customer service. Special instrument or software features or installed options may also be listed here.

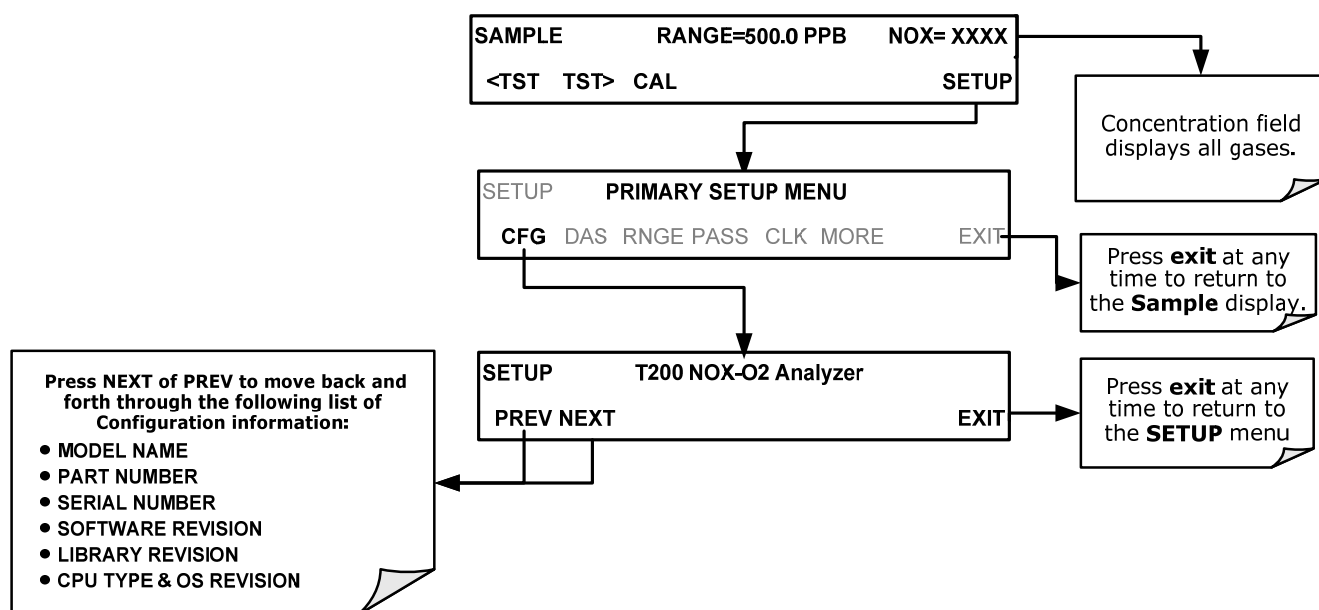

5.2. SETUP →ACAL: AUTOMATIC CALIBRATION OPTION

The menu button for this option appears only when the instrument has the zero span and/or IZS options. See Section 9.5 for details.

5.3. SETUP →DAS: INTERNAL DATA ACQUISITION SYSTEM

Use the SETUP>DAS menu to capture and record data. Refer to Section 7 for configuration and operation details.

5.4. SETUP →RNGE: ANALOG OUTPUT REPORTING RANGE CONFIGURATION

Use the SETUP>RNGE menu to configure output reporting ranges, including scaled reporting ranges to handle data resolution challenges. This section describes configuration for Single, Dual, and Auto Range modes.

5.4.1. 9110T PHYSICAL RANGES

The 9110T NO_x analyzer measures NO_x, NO and NO₂ concentrations from 2 to 20,000 ppb.

Electronically the 9110T analyzer converts the 0-5 volt analog signal output by the PMT into a digital signal with 4096 counts of resolution. Since its measurement range is 0 ppb to 20,000 ppb, this only allows about 3 ppb per count. While this might be acceptable for high concentration measurements made in parts per million units (ppm), it is not good enough for lower level NO_x measurements. To overcome this limitation the 9110T is designed with two physical measurement ranges:

- A **LOW** range that measures concentration from 0 ppb to 2,000 ppb with a resolution of 0.27 ppb per count.
- A **HIGH** range that measures the full 20,000 ppb range of the analyzer.

The analyzer's CPU chooses the appropriate range based on how the user sets up the reporting ranges for the instruments analog outputs when an analog range is selected with a lower limit between 0 and 2000 ppb the analyzer will utilize its low physical range. When an analog range is in use that has a reporting range with an upper limit set between 2001 and 20,000 ppb the instrument will operate in its high physical range.

Once both ranges have been using the same span gas values the analyzer's front panel will accurately report concentrations between 0 and 20,000 ppb, seamlessly switching between the low and high physical ranges regardless of the selected analog reporting range.

5.4.2. 9110T ANALOG OUTPUT REPORTING RANGES

For applications using chart recorders or other analog recording devices, the 9110T's 20,000 ppb physical range can cause resolution problems. For example, in an application where the expected concentrations of NO, NO₂ and NO_x are typically less than 500 ppb, the full scale of expected values is only 2.5% of the instrument's 20,000 ppb physical range. The corresponding output signal would then only be recorded across 2.5% of the range of the recording device.

The 9110T solves this problem by allowing the user to select a reporting range for the analog outputs that only includes that portion of the physical range that covers the specific application. This increases the reliability and accuracy of the analyzer by avoiding additional gain-amplification circuitry.

Note

Only the reporting range of the analog outputs is scaled.

Both the DAS values stored in the CPU's memory and the concentration values reported on the front panel are unaffected by the settings chosen for the reporting range(s) of the instrument.

5.4.2.1. Analog Output Ranges for NO_x, NO and NO₂ Concentration

The analyzer has three active analog output signals related to NO_x, NO and NO₂ concentration, accessible through a connector on the rear panel.

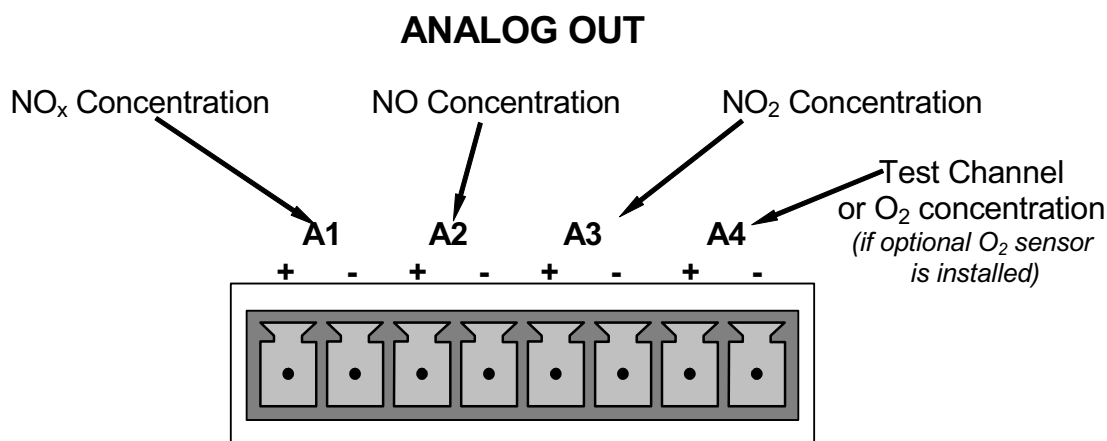

Figure 5-1: Analog Output Connector Pin Out

The **A1**, **A2** and **A3** channels output a signal that is proportional to the NO_x, NO and NO₂ concentrations of the sample gas, respectively. The 9110T can be set so that these outputs operate in one of the three following modes: single range mode, independent range mode, or automatic range mode (Section 5.4.3).

Additionally, the signal levels of outputs **A1**, **A2** and **A3** outputs can be:

- Configured full scale outputs of: 0 - 0.1 VDC; 0 - 1 VDC; 0 - 5 VDC or; 0 - 10 VDC.
- Equipped with optional 0-20 mADC current loop drivers (see Section 3.3.1.4) and configured for any current output within that range analog output (e.g. 0-20 mA, 2-20 mA, 4-20 mA, etc.).

Together these two set of parameters allow the user a great deal of flexibility in how the instrument reports NO_x , NO and NO₂ concentration to external devices. For example, Using the **IND** mode the following configuration could be created:

A1 OUTPUT: NO_x Output Signal = 4 – 20 mA representing 0-1000 ppb concentration values

A2 OUTPUT: NO Output Signal = 0 – 10 VDC representing 0-500 ppb concentration values.

A3 OUTPUT: NO₂ Output Signal = 0 – 5 VDC representing 0-500 ppb concentration values.

The user may also add a signal offset independently to each output (see Section 5.9.3.9) to match the electronic input requirements of the recorder or data logger to which the output is connected.

IMPORTANT

IMPACT ON READINGS OR DATA

The instrument does not remember upper range limits settings associated with the individual modes. Changes made to the range limits (e.g. 400 ppb → 600 ppb) when in one particular mode will alter the range limit settings for the other modes.

When switching between reporting range modes, **ALWAYS** check and

reset the upper range limits for the new mode selection..

5.4.2.2. Analog Output Reporting Range Default Settings

The default setting for these the reporting ranges of the analog output channels **A1**, **A2** and **A3** are:

- SNGL mode
- 0 to 500.0 ppb
- 0 to 5 VDC

5.4.3. SETUP → RNGE → MODE

Single range mode (SNGL) reports all three of the NO_x gas concentrations using the same reporting range span (see Section 5.4.3.1).

Independent range mode (IND) allows the NO_x, NO and NO₂ analog outputs to be set with different reporting range spans (see Section 5.4.3.2).

Automatic range mode (AUTO) allows the analyzer to automatically switch the reporting range between two user upper span limits (designated LOW and HIGH) based on the actual concentrations being measured for each (see Section 5.4.3.3). These are not the same as the analyzer's low and high physical ranges.

5.4.3.1. SETUP → RNGE → MODE → SNGL: Configuring the 9110T Analyzer for Single Range Mode

Note

Single Range is the default reporting range mode for the analyzer.

When the single range mode is selected (**SNGL**), all analog NO_x, NO and NO₂ concentration outputs (**A1**, **A2** and **A3**) are slaved together and set to the same reporting range limits (e.g. 500.0 ppb). This reporting range can be set to any value between 100 ppb and 20,000 ppb.

Although all three NO_x outputs share the same concentration reporting range, the electronic signal ranges of the analog outputs may still be configured for different values (e.g. 0-5 VDC, 0-10 VDC, etc; see Section 5.9.3.1).

To select **SNGL** range mode and to set the upper limit of the range, press:

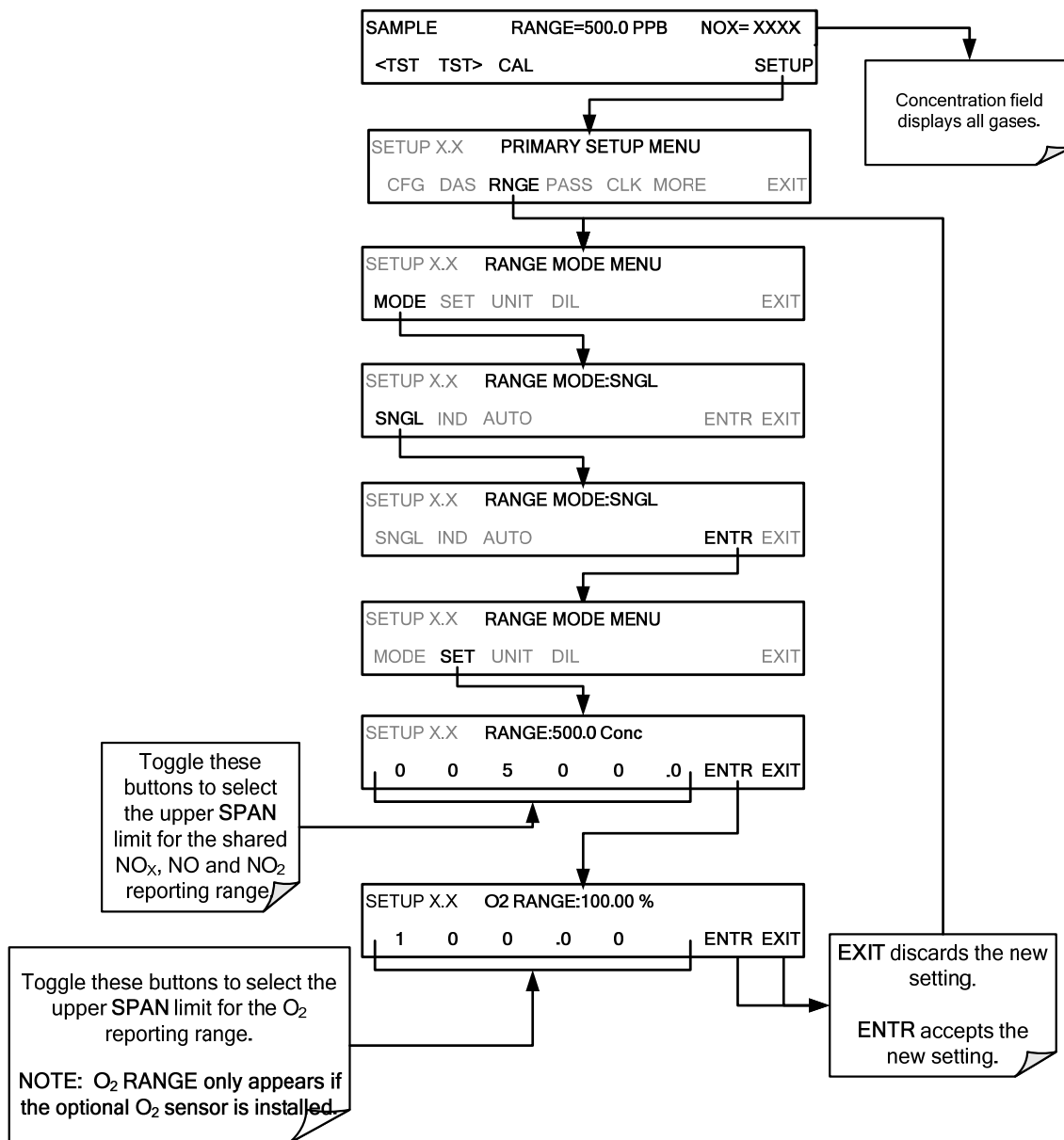

5.4.3.2. SETUP → RNGE → MODE → IND: Configuring the 9110T Analyzer for Independent Range Mode

The independent range mode (IND) assigns the three NO_x, NO and NO₂ concentrations to individual analog output channels. In IND range mode the RANGE test function displayed on the front panel will then be replaced by three separate functions:

Table 5-1: IND Mode Analog Output Assignments

TEST FUNCTION	CONCENTRATION REPORTED	ANALOG OUTPUT CHANNEL
RANGE1	NO _x	A1
RANGE2	NO	A2
RANGE3	NO ₂	A3

Each can be configured with a different reporting range upper limit and analog signal span:

EXAMPLE:

- NO_x Concentration – **RANGE1** Set for 0-800 ppb & output **A1** set for 0-10 VDC
- NO Concentration – **RANGE2** Set for 0-200 ppb & output **A2** set for 0-5 VDC
- NO₂ Concentration – **RANGE3** Set for 0-400 ppb & output **A3** set for 0-5 VDC

Setting analog range limits to different values does not affect the instrument’s calibration.

To select the **IND** range mode, press the following buttons:

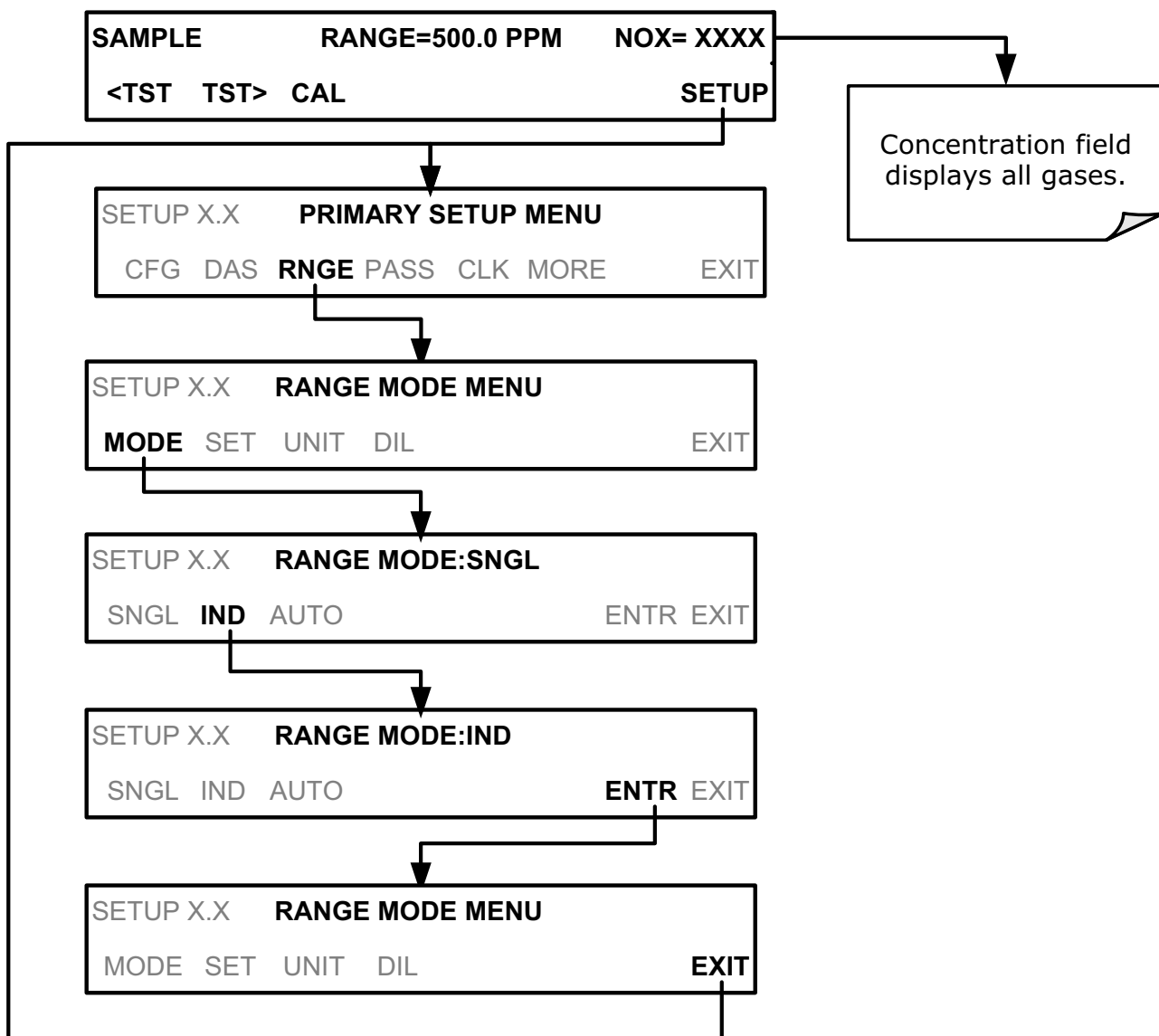

To set the upper range limit for each independent reporting range, press:

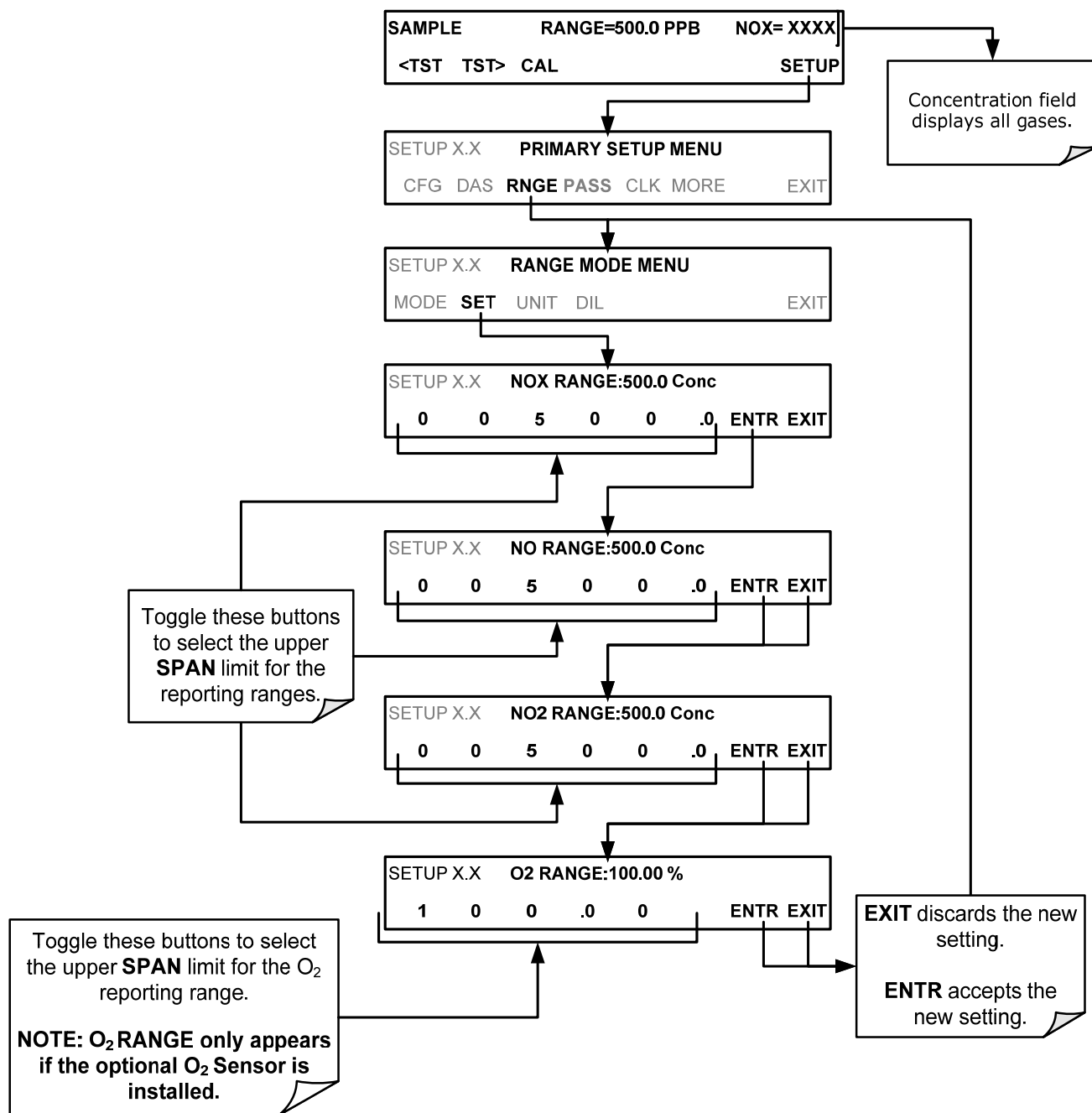

5.4.3.3. SETUP → RNGE → MODE → AUTO: Configuring the 9110T Analyzer for Auto Range Mode

In **AUTO** range mode, the analyzer automatically switches the reporting range between two user-defined ranges (**LOW** and **HIGH**). The same low and high span settings are applied equally to NO, NO₂ and NO_x readings.

- The unit will switch from **LOW** range to **HIGH** range when either the NO, or NO_x concentration exceeds 98% of the low range span.
- The unit will return from **HIGH** range back to **LOW** range once both the NO and NO_x concentrations fall below 75% of the low range span.

IMPORTANT

IMPACT ON READINGS OR DATA

The **LOW & HIGH** ranges referred to here are **NOT** the same as the low & high physical ranges referred to in Section 5.4.1.

Also the **RANGE** test function displayed on the front panel will be replaced by two separate functions:

- RANGE1: The LOW range setting for all analog outputs.
- RANGE2: The HIGH range setting for all analog outputs.

The **LOW/HIGH** range status is also reported through the external, digital status bits (Section 3.3.1.4). To set individual ranges press the following menu sequence.

NOTE:
 Avoid accidentally setting the **LOW** range (**RANGE1**) of the instrument with a higher span limit than the **HIGH** range (**RANGE2**).
 This will cause the unit to stay in the low reporting range perpetually and defeat the function of the **AUTO** range mode.

The **LOW** and **HIGH** ranges have separate slopes and offsets for computing the NO_x and NO concentration.
 The two ranges must be independently calibrated.

Toggle these buttons to select the upper **SPAN** limit for the reporting range.

SAMPLE RANGE=500.0 PPB NOX= XXXX
 <TST TST> CAL SETUP

Concentration field displays all gases.

SETUP X.X PRIMARY SETUP MENU
 CFG DAS RNGE PASS CLK MORE EXIT

SETUP X.X RANGE MODE MENU
 MODE SET UNIT DIL EXIT

SETUP X.X RANGE MODE:SNGL
 SNGL IND AUTO DIL ENTR EXIT

SETUP X.X RANGE MODE:AUTO
 SNGL IND AUTO ENTR EXIT

SETUP X.X RANGE MODE MENU
 MODE SET UNIT DIL EXIT

SETUP X.X LOW RANGE:50.0 Conc
 0 0 5 0 0 .0 ENTR EXIT

SETUP X.X HIGH RANGE:200.0 Conc
 0 0 5 0 0 .0 ENTR EXIT

EXIT discards the new setting.
 ENTR accepts the new setting.

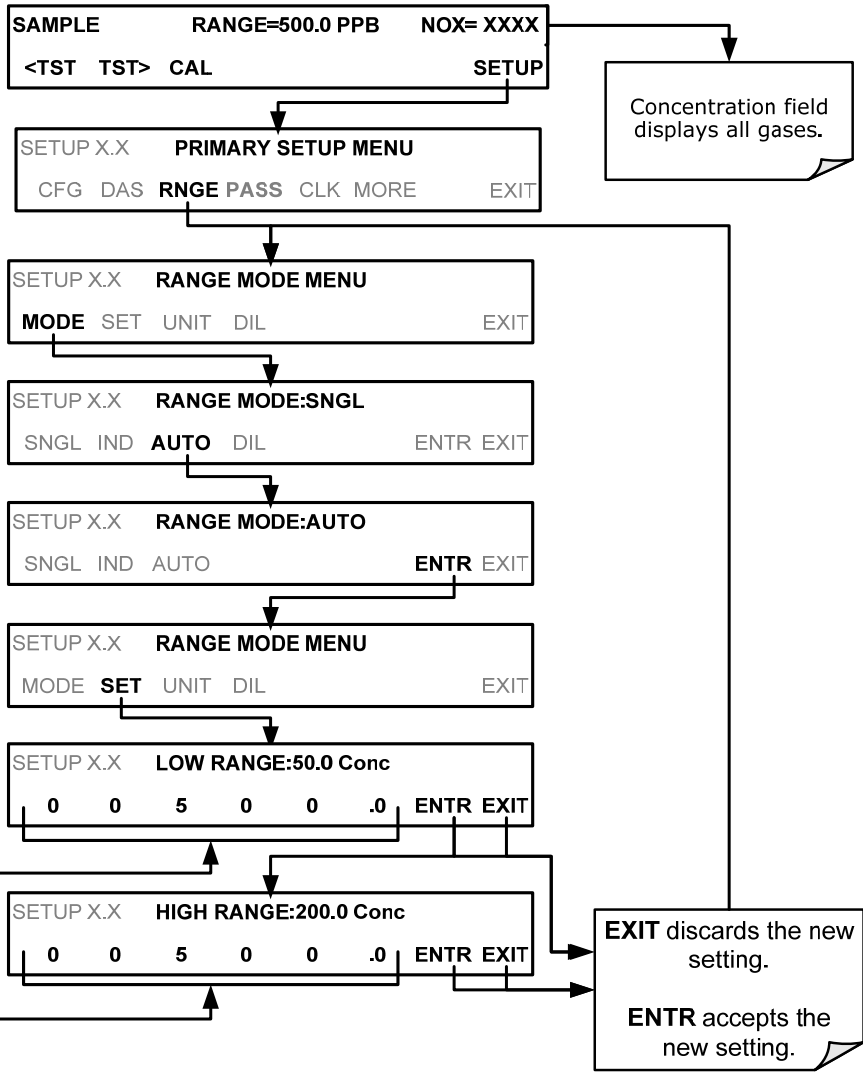

5.4.3.4. SETUP → RNGE → UNIT: Setting the Reporting Range Units of Measure

The 9110T can display and report concentrations in ppb, ppm, ug/m³, mg/m³ units. Changing units affects all of the COMM port values, and all of the display values for all reporting ranges. To change the units of measure press:

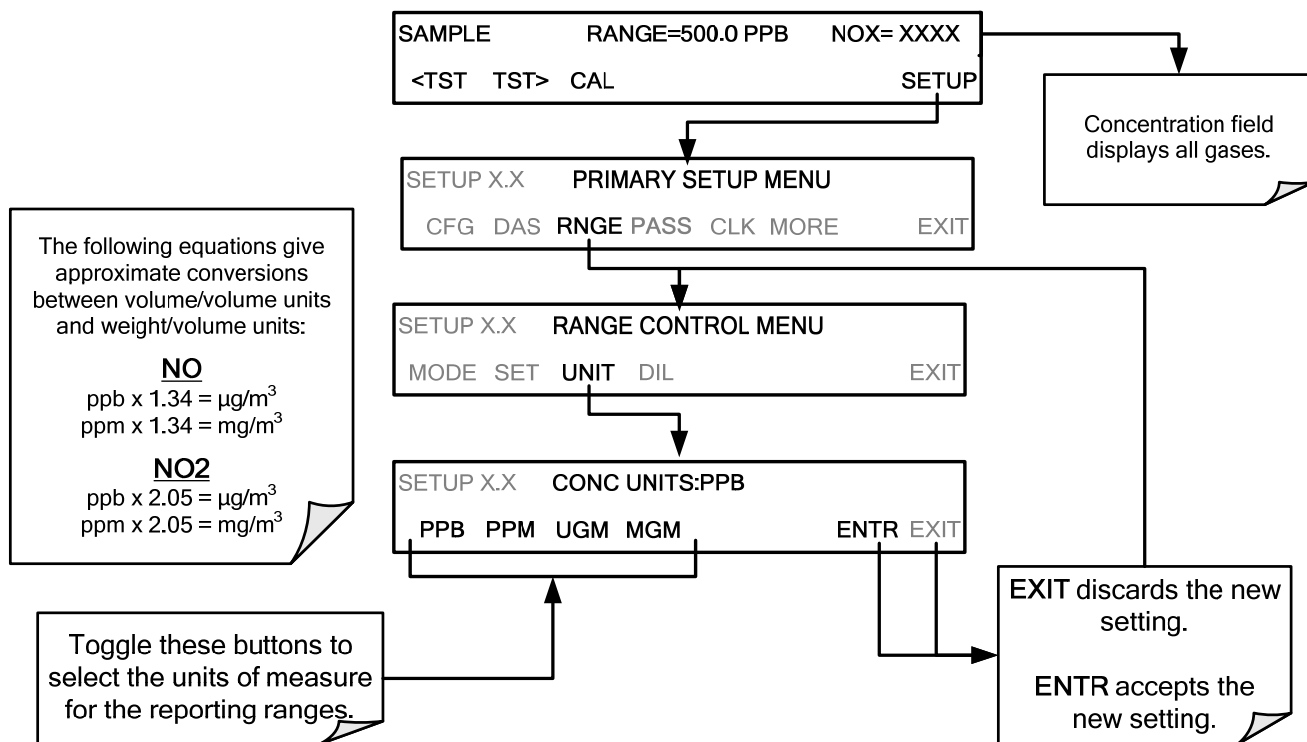

IMPORTANT

IMPACT ON READINGS OR DATA

Concentrations displayed in mg/m³ and ug/m³ use 0°C @ 760 mmHg for Standard Temperature and Pressure (STP).

Consult your local regulations for the STP used by your agency. (Example: US EPA uses 25°C as the reference temperature).

Once the Units of Measurement have been changed from volumetric (ppb or ppm) to mass units (ug/m³ or mg/m³) the analyzer **MUST** be recalibrated, as the “expected span values” previously in effect will no longer be valid.

Simply entering new expected span values without running the entire calibration routine is not sufficient. This will also counteract any discrepancies between STP definitions.

5.4.3.5. SETUP → RNGE → DIL: Using the Optional Dilution Ratio Feature

The dilution ratio feature is a software utility option designed for applications where the sample gas is diluted before being analyzed by the 9110T. Typically this occurs in continuous emission monitoring (CEM) applications where the quality of gas in a smoke stack is being tested and the sampling method

used to remove the gas from the stack dilutes the gas. Once the degree of dilution is known, this feature allows the user to add an appropriate scaling factor to the analyzer's NO, NO₂ and NO_x concentration calculations so that the measurement range and concentration values displayed on the instrument's front panel display and reported via the instruments various outputs reflect the undiluted values.

Using the Dilution Ratio option is a 4-step process:

1. Select the appropriate units of measure (see Section 5.4.3.4).
2. Select the reporting range mode and set the reporting range upper limit (see Section 5.4.2).
- Ensure that the upper span limit entered for the reporting range is the maximum expected concentration of the **UNDILUTED** gas.
3. Set the dilution factor as a gain (e.g., a value of 20 means 20 parts diluent and 1 part of sample gas):

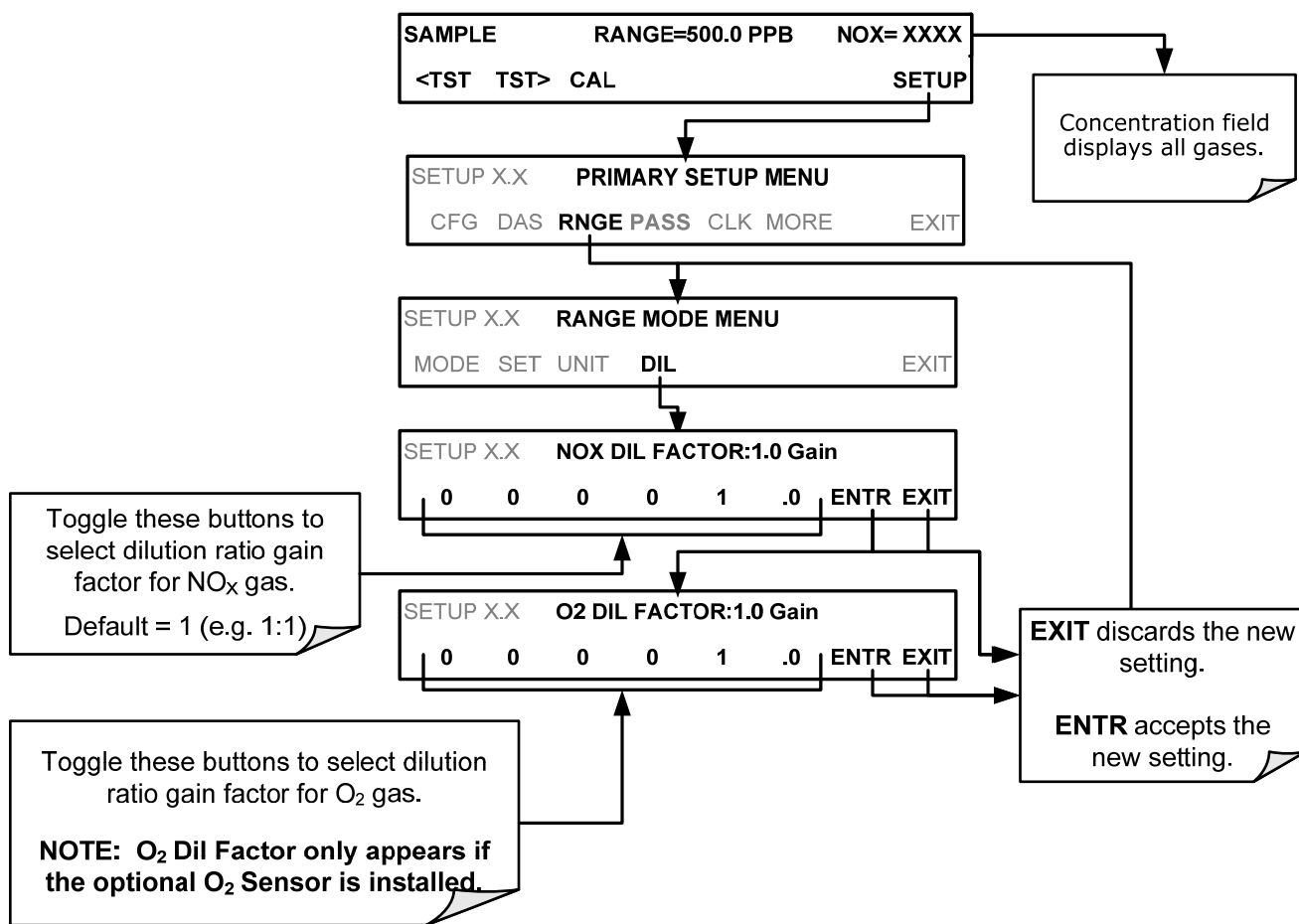

1. Calibrate the analyzer.
 - Ensure that the calibration span gas is either supplied through the same dilution system as the sample gas or has an appropriately lower actual concentration.

EXAMPLE: If the reporting range limit is set for 100 ppm and the dilution ratio of the sample gas is 20 gain, either:

- a span gas with the concentration of 100 ppm can be used if the span gas passes through the same dilution steps as the sample gas, or;
- a 5 ppm span gas must be used if the span gas **IS NOT** routed through the dilution system.

5.5. SETUP → PASS: PASSWORD PROTECTION

The 9110T provides password protection of the calibration and setup functions to prevent unauthorized adjustments. When the passwords have been enabled in the **PASS** menu item, the system will prompt the user for a password anytime a password-protected function (e.g., SETUP) is selected. This allows normal operation of the instrument, but requires the password (101) to access to the menus under SETUP. When PASSWORD is disabled (SETUP>OFF), any operator can enter the Primary Setup (SETUP) and Secondary Setup (SETUP>MORE) menus. Whether PASSWORD is enabled or disabled, a password (default 818) is required to enter the VARS or DIAG menus in the SETUP>MORE menu.

There are three levels of password protection, which correspond to operator, maintenance and configuration functions. Each level allows access to all of the functions in the previous level.

Table 5-2: Password Levels

PASSWORD	LEVEL	MENU ACCESS ALLOWED
Null (000)	Operation	All functions of the MAIN menu: TEST, GEN , initiate SEQ, MSG, CLR
101	Configuration/Maintenance	Access to Primary Setup and Secondary SETUP Menus when PASSWORD is enabled.
818	Configuration/Maintenance	Access to Secondary SETUP Submenus VARs and DIAG whether PASSWORD is enabled or disabled .

To enable passwords, press:

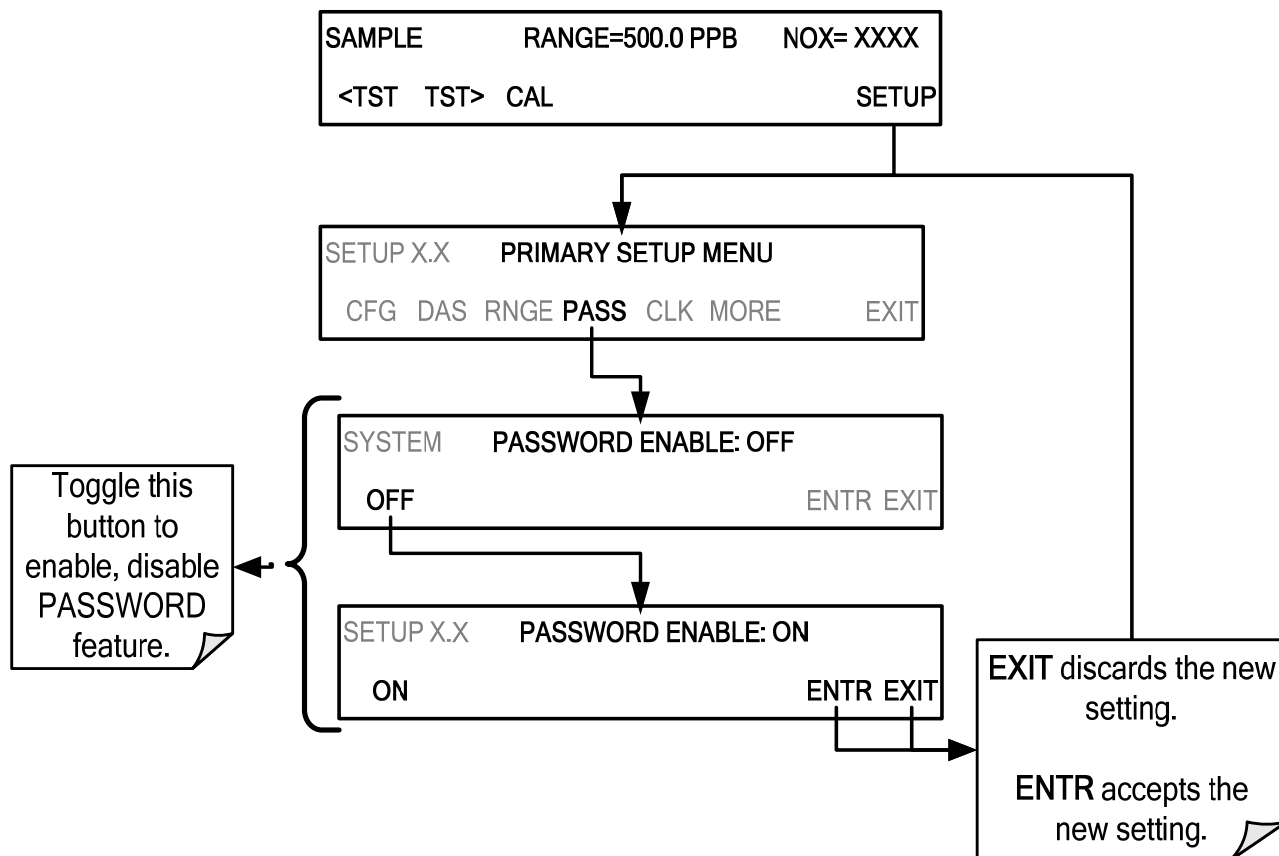

Example: If all passwords are enabled, the following touchscreen control sequence would be required to enter the **VARs** or **DIAG** submenus:

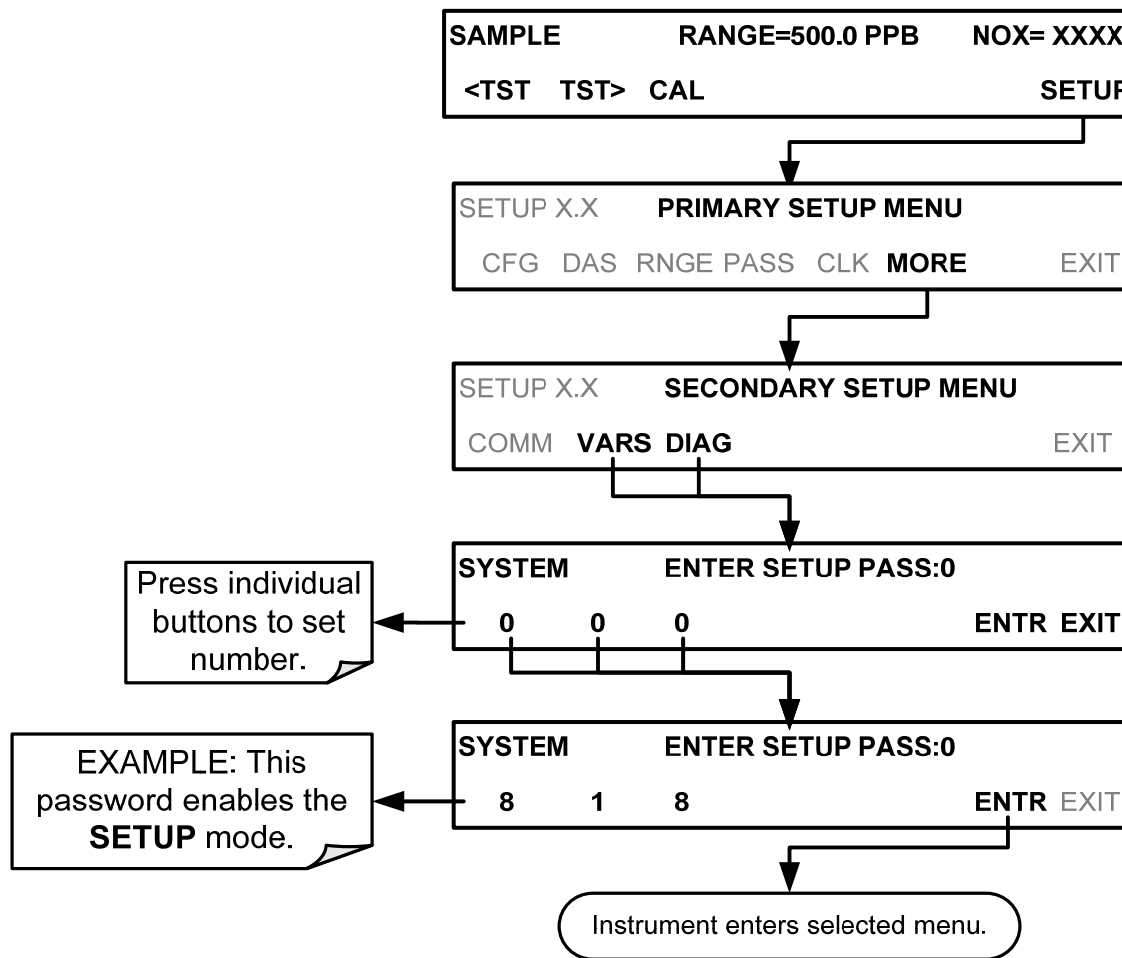

Note

The instrument still prompts for a password when entering the **VARs** and **DIAG** menus, even if passwords are disabled, but it displays the default password (818) upon entering these menus. In this case, the user only has to press **ENTR** to access the password-protected menus.

In order to disable the **PASSWORD** feature after it has been turned **ON**, the **SETUP** menu first requires a password; once the password has been input and the **ENTR** button pressed, the **PRIMARY SETUP MENU** appears, and now the **PASS** menu can be accessed, where pressing the **ON** button turns **PASSWORD ENABLE** back to **OFF**, and pressing the **ENTR** button accepts the change (Table 5-2).

5.6. SETUP → CLK: SETTING THE INTERNAL TIME-OF-DAY CLOCK

The 9110T has an internal clock for setting the time and day; it's speed can be adjusted to compensate for faster or slower CPU clocks. Press SETUP>CLK to access the clock.

5.6.1. SETTING THE TIME OF DAY

The time-of-day feature of the internal clock supports the **DURATION** step of the automatic calibration (ACAL) sequence feature, has a built-in clock for the AutoCal timer, for the time TEST function, and for time stamps on COM port messages and on DAS data entries.

To set the clock's time and date, press:

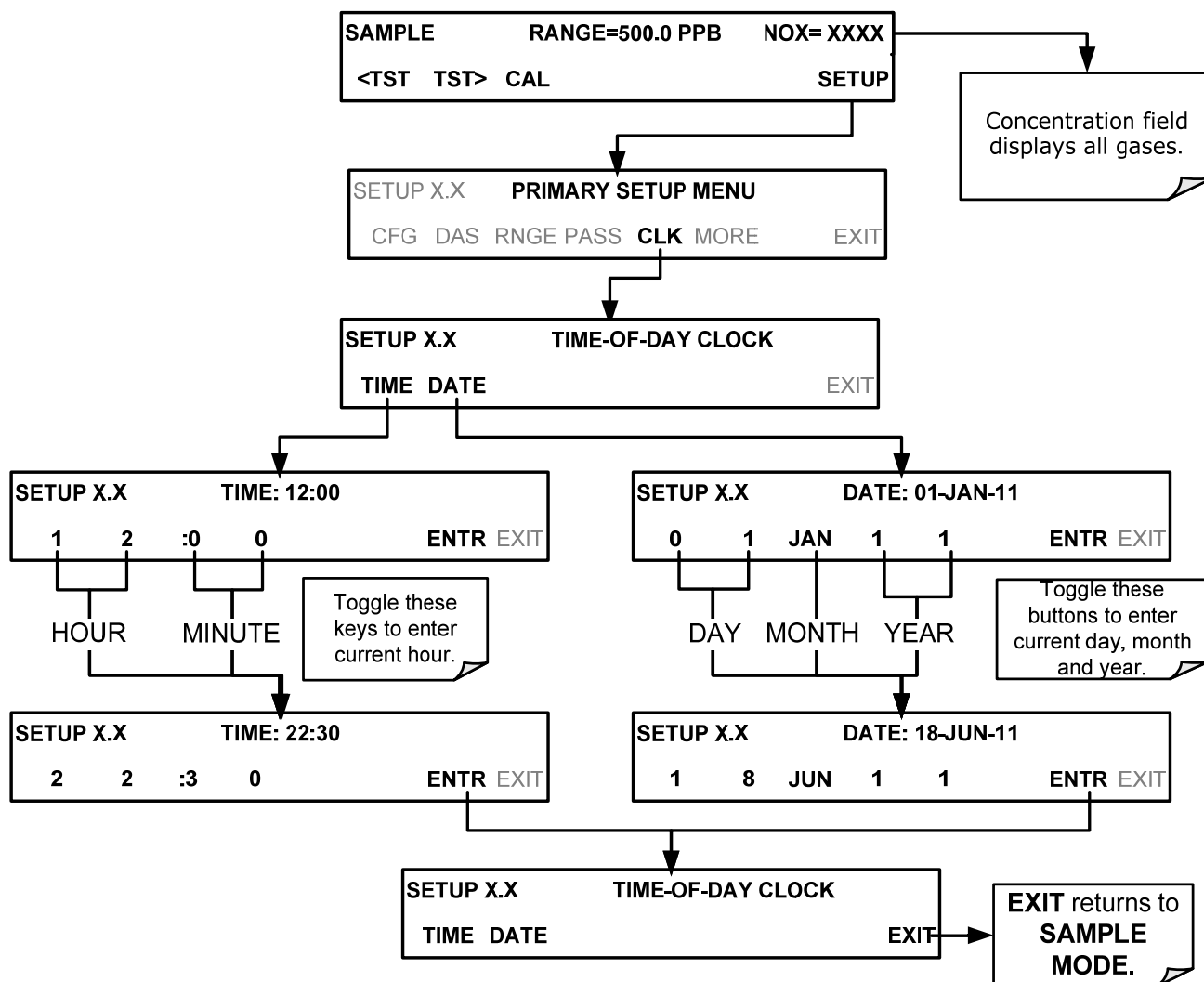

5.6.2. ADJUSTING THE INTERNAL CLOCK'S SPEED

In order to compensate for CPU clocks that run fast or slow, you can adjust a variable called **CLOCK_ADJ** to speed up or slow down the clock by a fixed amount every day.

The **CLOCK_ADJ** variable is accessed via the **VARs** submenu: To change the value of this variable, press:

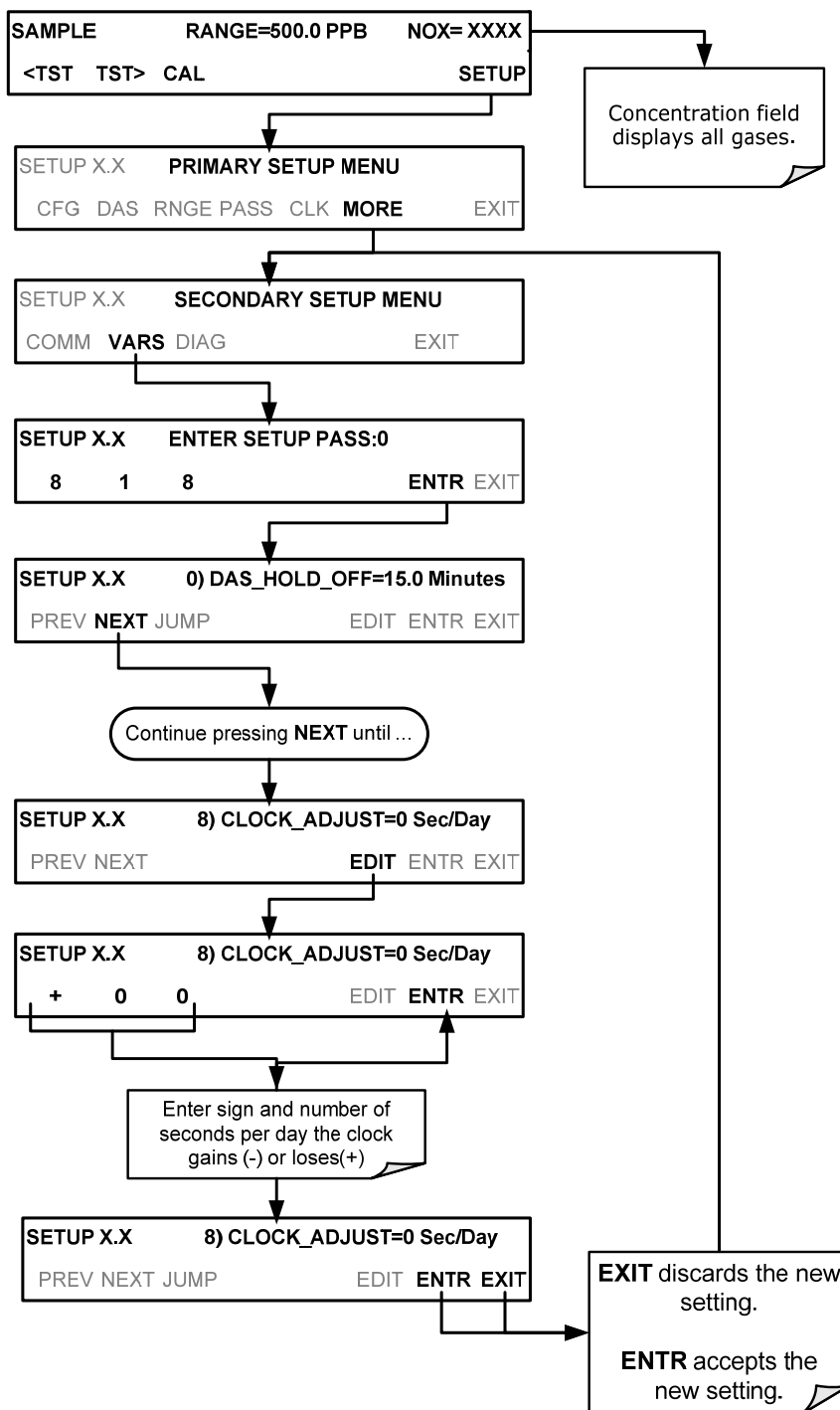

5.7. SETUP → COMM: COMMUNICATIONS PORTS

This section introduces the communications setup menu; Section 6 provides the setup instructions and operation information. Press **SETUP>ENTR>MORE>COMM** to arrive at the communications menu.

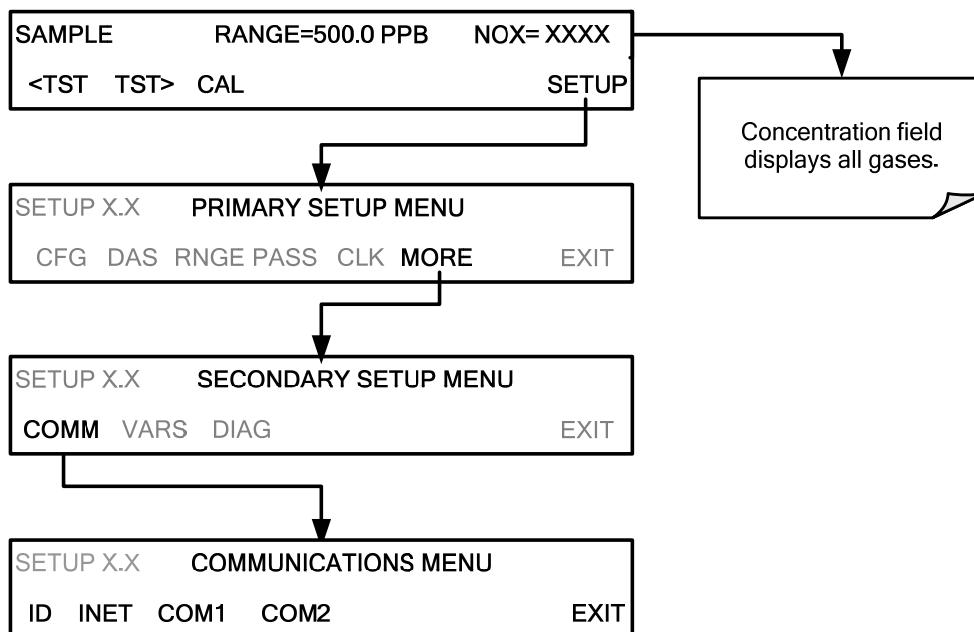

Figure 5-2. SETUP – COMM Menu

5.7.1. ID (MACHINE IDENTIFICATION)

In the **SETUP>MORE>COMM** menu press **ID** to display and/or change the Machine ID, which must be changed to a unique identifier (number) when more than one instrument of the same model is used:

- in an RS-232 multidrop configuration (Sections 3.3.1.8)
- on the same Ethernet LAN (Section 6.5)

The default ID for the Model 9110T is 0200. Press any button(s) in the MACHINE ID menu (Figure 5-3) until the Machine ID in the Parameter field displays the desired identifier.

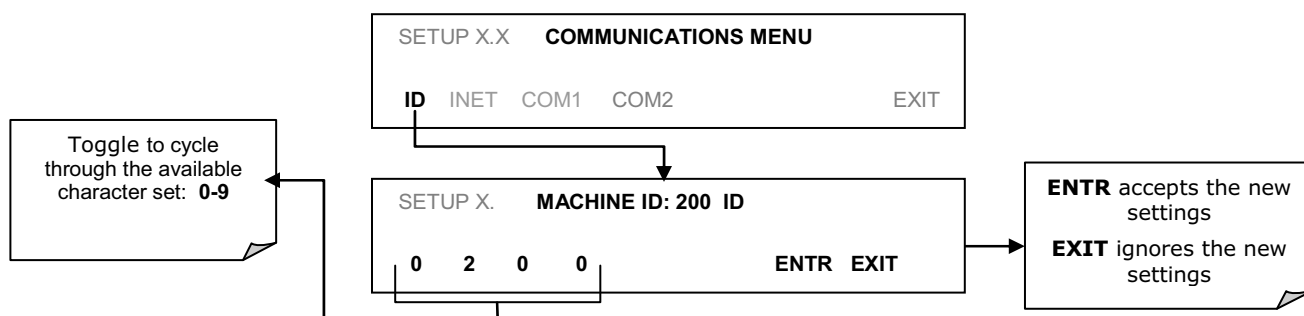

Figure 5-3. COMM– Machine ID

The ID can be any unique 4-digit number and can also be used to identify analyzers in any number of ways (e.g. location numbers, company asset number, etc.)

5.7.2. INET (ETHERNET)

Use SETUP>COMM>INET to configure Ethernet communications, whether manually or via DHCP. Please see Section 6.5.2 for configuration details.

5.7.3. COM1[COM2] (MODE, BAUDE RATE AND TEST PORT)

Use the SETUP>COMM>COM1[COM2] menus to:

- configure communication modes (Section 6.2.1)
- view/set the baud rate (Section 6.2.2)
- test the connections of the com ports (Section 6.2.3).

Configuring COM1 or COM2 requires setting the DCE DTE switch on the rear panel. Section 6.1 provides DCE DTE information.

5.8. SETUP → VARS: VARIABLES SETUP AND DEFINITION

Through the SETUP>MORE>VARS menu there are several user-adjustable software variables that define certain operational parameters. Usually, these variables are automatically set by the instrument's firmware, but can be manually re-defined using the **VARS** menu.

Table 5-3 lists all variables that are available within the 818 password protected level. See Appendix A2 for a detailed listing of all of the 9110T variables that are accessible through the remote interface.

Table 5-3: Variable Names (VARS)

NO.	VARIABLE	DESCRIPTION	ALLOWED VALUES	VARS DEFAULT VALUES
0	DAS_HOLD_OFF	Changes the Internal Data Acquisition System (DAS) HOLDOFF timer: No data is stored in the DAS channels during situations when the software considers the data to be questionable such as during warm up of just after the instrument returns from one of its calibration mode to SAMPLE Mode.	May be set for intervals between 0.5 – 20 min	15 min.
1	MEASURE_MODE	Selects the gas measurement mode in which the instrument is to operate. NO _x only, NO only or NO _x and NO simultaneously.	NO; NO _x ; NO _x –NO	NO _x –NO
2	STABIL_GAS	Selects which gas measurement is displayed when the STABIL test function is selected	NO; NO _x ; NO ₂ ;	NO _x
3	TPC_ENABLE	Enables or disables the Temperature and Pressure Compensation (TPC) feature (Section 13.9.2).	ON/OFF	ON

NO.	VARIABLE	DESCRIPTION	ALLOWED VALUES	VARS DEFAULT VALUES
4	DYN_ZERO ¹	Dynamic zero automatically adjusts offset and slope of the NO and NO _x response when performing a zero point calibration during an AutoCal (see Section 9.5).	ON/OFF	OFF
5	DYN_SPAN ¹	Dynamic span automatically adjusts the offsets and slopes of the NO and NO _x response when performing a sp point calibration during an AutoCal (see Section 9.5).	ON/OFF	OFF
6	IZS_SET	Sets the internal span gas generator's permeation tube oven temperature. Changing this temperature will impact the NO ₂ permeation rate (Section 3.3.2.5).	30°C - 70°C	51°C
7	CONC_PRECISION	Allows the user to set the number of significant digits to the right of the decimal point display of concentration and stability values.	AUTO, 1, 2, 3, 4	AUTO
8	CLOCK_ADJ	Adjusts the speed of the analyzer's clock. Choose the + sign if the clock is too slow, choose the - sign if the clock is too fast.	-60 to +60 s/day	0 sec
9	CAL_ON_NO ₂	Allows turning ON and OFF the ability to span the analyzer with NO ₂ , in which case the instrument acts as if NO and NO _x are spanned, even though it is supplied with NO ₂ . The NO ₂ concentration is then zero by default.	ON or OFF	OFF

¹ Use of the DYN_ZERO and DYN_SPAN features are not allowed for applications requiring EPA equivalency.

IMPORTANT**IMPACT ON READINGS OR DATA**

There are more VARS available when using the password, 929, for configuration. Use caution when pressing any buttons while in this setup. Any changes made may alter the performance of the instrument or cause the instrument to not function properly. Note that if there is an accidental change to a setup parameter, press EXIT to discard the changes.

Note

There is a 2-sec latency period between when a VARS value is changed and the new value is stored into the analyzer's memory. DO NOT turn the analyzer off during this period or the new setting will be lost.

To access and navigate the **VARS** menu, use the following button sequence:

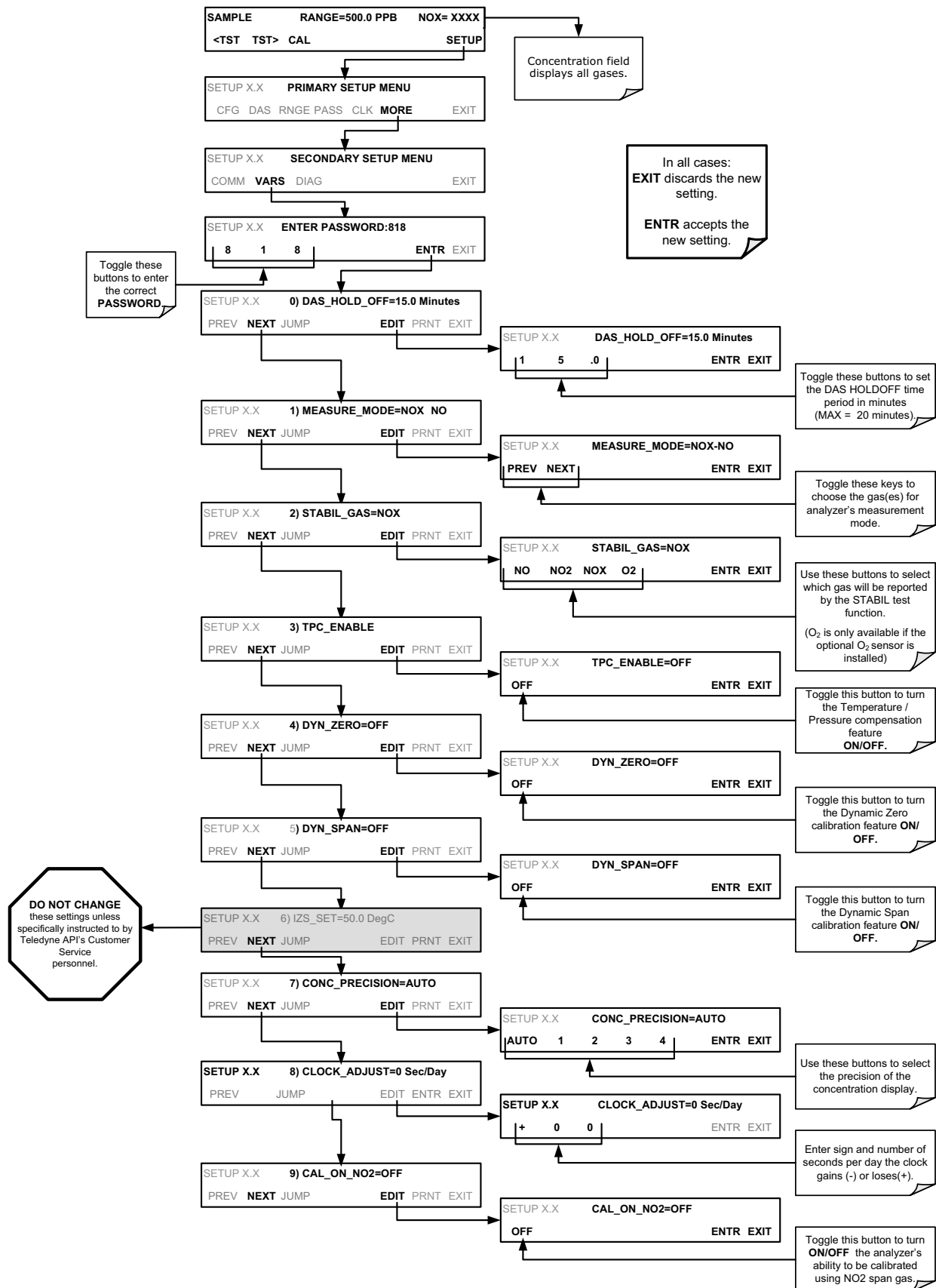

5.9. SETUP → DIAG: DIAGNOSTICS FUNCTIONS

A series of diagnostic tools is grouped together under the **SETUP→MORE→DIAG** menu. The parameters are dependent on firmware revision (see Appendix A). These tools can be used in a variety of troubleshooting and diagnostic procedures and are referred to in many places of the maintenance and troubleshooting sections of this manual.

The various operating modes available under the **DIAG** menu are:

Table 5-4: Diagnostic Mode (DIAG) Functions

DIAG SUBMENU	SUBMENU FUNCTION	Front Panel Mode Indicator	MANUAL SECTION
SIGNAL I/O	Allows observation of all digital and analog signals in the instrument. Allows certain digital signals such as valves and heaters to be toggled ON and OFF .	DIAG I/O	12.1.3
ANALOG OUTPUT	When entered, the analyzer performs an analog output step test. This can be used to calibrate a chart recorder or to test the analog output accuracy.	DIAG AOUT	12.7.6.1
ANALOG I/O CONFIGURATION	The signal levels of the instruments analog outputs may be calibrated (either individually or as a group). Various electronic parameters such as signal span, and offset are available for viewing and configuration.	DIAG AIO	5.9.2
TEST CHAN OUTPUT	Selects one of the available test channel signals to output over the A4 analog output channel.	DIAG TCHN	5.9.4
OPTIC TEST	When activated, the analyzer performs an optic test, which turns on an LED located inside the sensor module near the PMT (Figure 13-20). This diagnostic tests the response of the PMT without having to supply span gas.	DIAG OPTIC	0
ELECTRICAL TEST	When activated, the analyzer performs an electrical test, which generates a current intended to simulate the PMT output to verify the signal handling and conditioning of the PMT preamp board.	DIAG ELEC	0
OZONE GEN OVERRIDE ¹	Allows the user to manually turn the O ₃ generator on or off. During initial power up TMR (timer) is displayed while the Ozone brick remains off for the first 30 minutes.	DIAG OZONE	0
FLOW CALIBRATION ¹	This function is used to calibrate the gas flow output signals of sample gas and ozone supply.	DIAG FCAL	9.7

¹ These settings are retained after exiting DIAG mode.

To access the various **DIAG** submenus, press the following buttons:

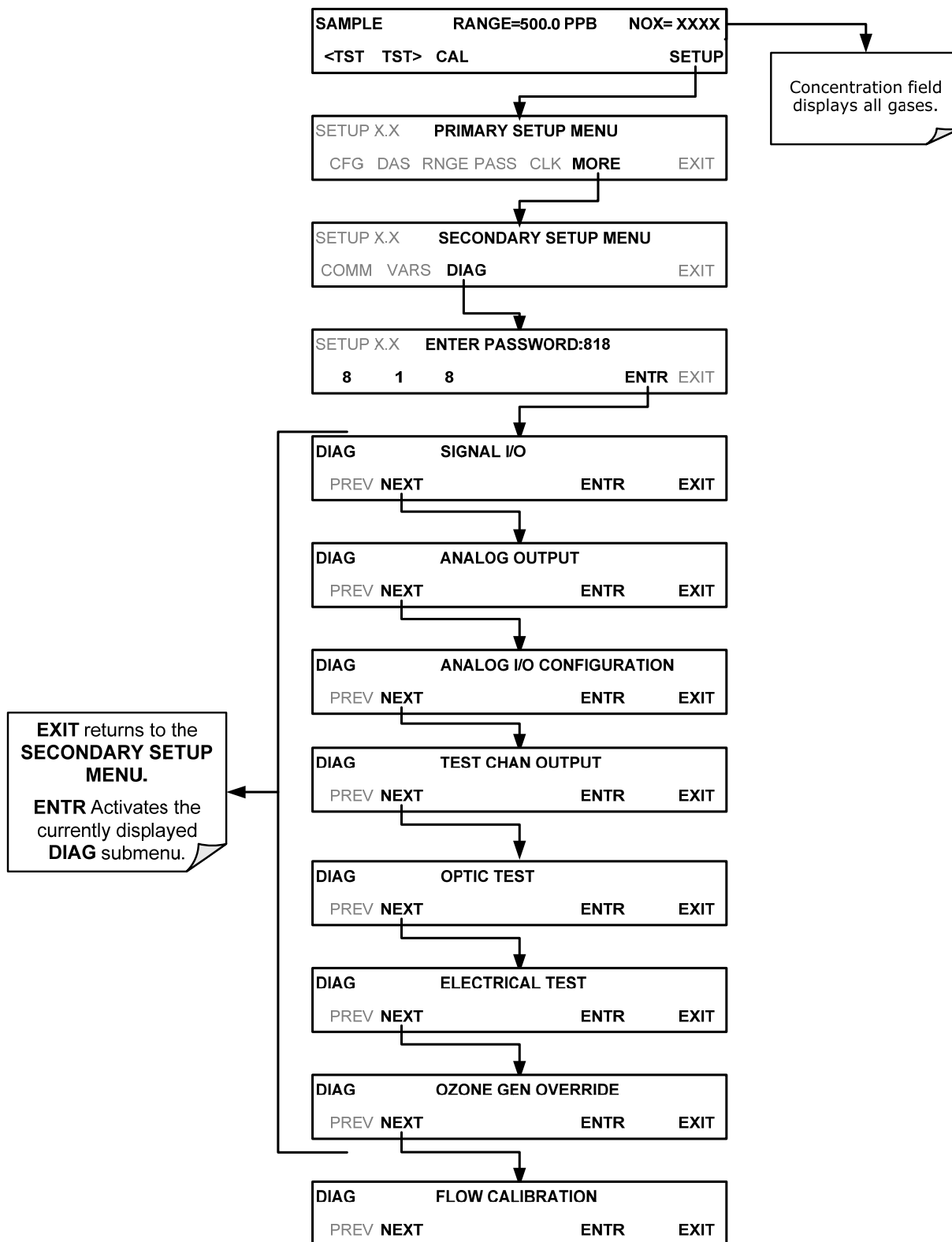

Figure 5-4: Accessing the DIAG Submenus

5.9.1. SIGNAL I/O

The signal I/O diagnostic mode allows a user to review and change the digital and analog input/output functions of the analyzer. Refer to Appendix A for a complete list of the parameters available for review under this menu.

IMPORTANT

IMPACT ON READINGS OR DATA

Any changes of signal I/O settings will remain in effect only until the signal I/O menu is exited. Exceptions are the ozone generator override and the flow sensor calibration, which remain as entered when exiting.

Access the signal I/O test mode from the DIAG Menu (Figure 5-4), then press:

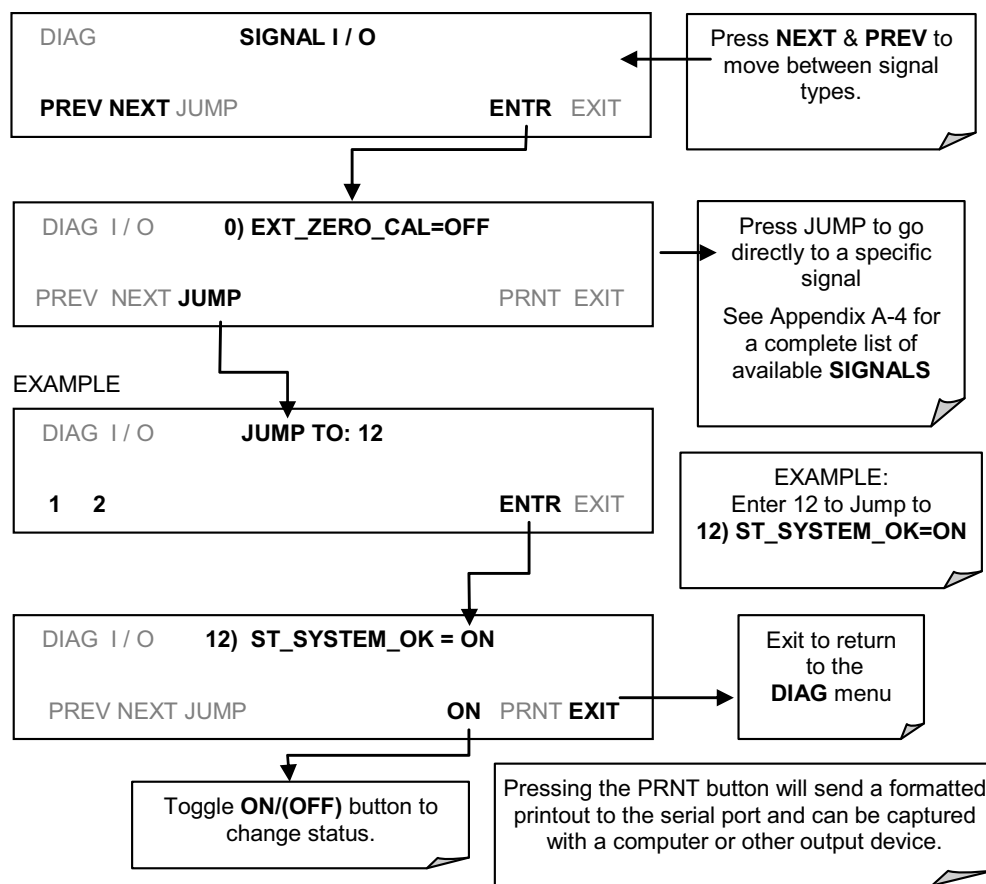

5.9.2. ANALOG OUTPUT (DIAG AOUT)

Analog Output is used to verify functionality and accuracy of the analog outputs. The test forces all analog output channels to produce signals ranging from 0% to 100% of the full scale range in 20% increments. This test is useful to verify the operation of the data logging/recording devices attached to the analyzer.

Section 12.7.6.1 presents instructions for use in troubleshooting and service.

5.9.3. ANALOG I/O CONFIGURATION (DIAG AIO)

The 9110T analyzer comes equipped with four analog outputs. The first three outputs (**A1 A2, & A3**) carry analog signals that represent the currently measured concentration of NO_x, NO and NO₂ (see Section 5.4.2.1). The fourth output (**A4**) outputs a signal that can be set to represent the current value of one of several test functions (see Table 5-9).

The following table lists the analog I/O functions that are available in the 9110T analyzer.

Table 5-5: DIAG - Analog I/O Functions

SUB MENU	FUNCTION	MANUAL SECTION
AOUT CALIBRATED	Initiates a calibration of the A1, A2, A3 and A4 analog output channels that determines the slope and offset inherent in the circuitry of each output. These values are stored and applied to the output signals by the CPU automatically.	5.9.3.1
CONC_OUT_1	Sets the basic electronic configuration of the A1 output (NO _x Concentration). There are four options: <ul style="list-style-type: none"> • RANGE¹: Selects the signal type (voltage or current loop) and level of the output • REC OFS: Allows them input of a DC offset to let the user manually adjust the output level • AUTO CAL: Enables / Disables the AOUT CALIBRATION Feature • CALIBRATED: Performs the same calibration as AOUT CALIBRATED, but on this one channel only. 	5.9.2
CONC_OUT_2	• Same as for CONC_OUT_1 but for analog channel A2 (NO Concentration)	
CONC_OUT_3	• Same as for CONC_OUT_1 but for analog channel A3 (NO ₂ Concentration)	
TEST OUTPUT	• Same as for CONC_OUT_1 but for analog channel A4 (TEST CHANNEL)	5.9.4
AIN CALIBRATED	Initiates a calibration of the A-to-D Converter circuit located on the Motherboard.	5.9.3.10
XIN1 . . . XIN8	For each of 8 external analog inputs channels, shows the gain, offset, engineering units, and whether the channel is to show up as a Test function.	5.9.3.11

To access the ANALOG I/O CONFIGURATION sub menu, press:

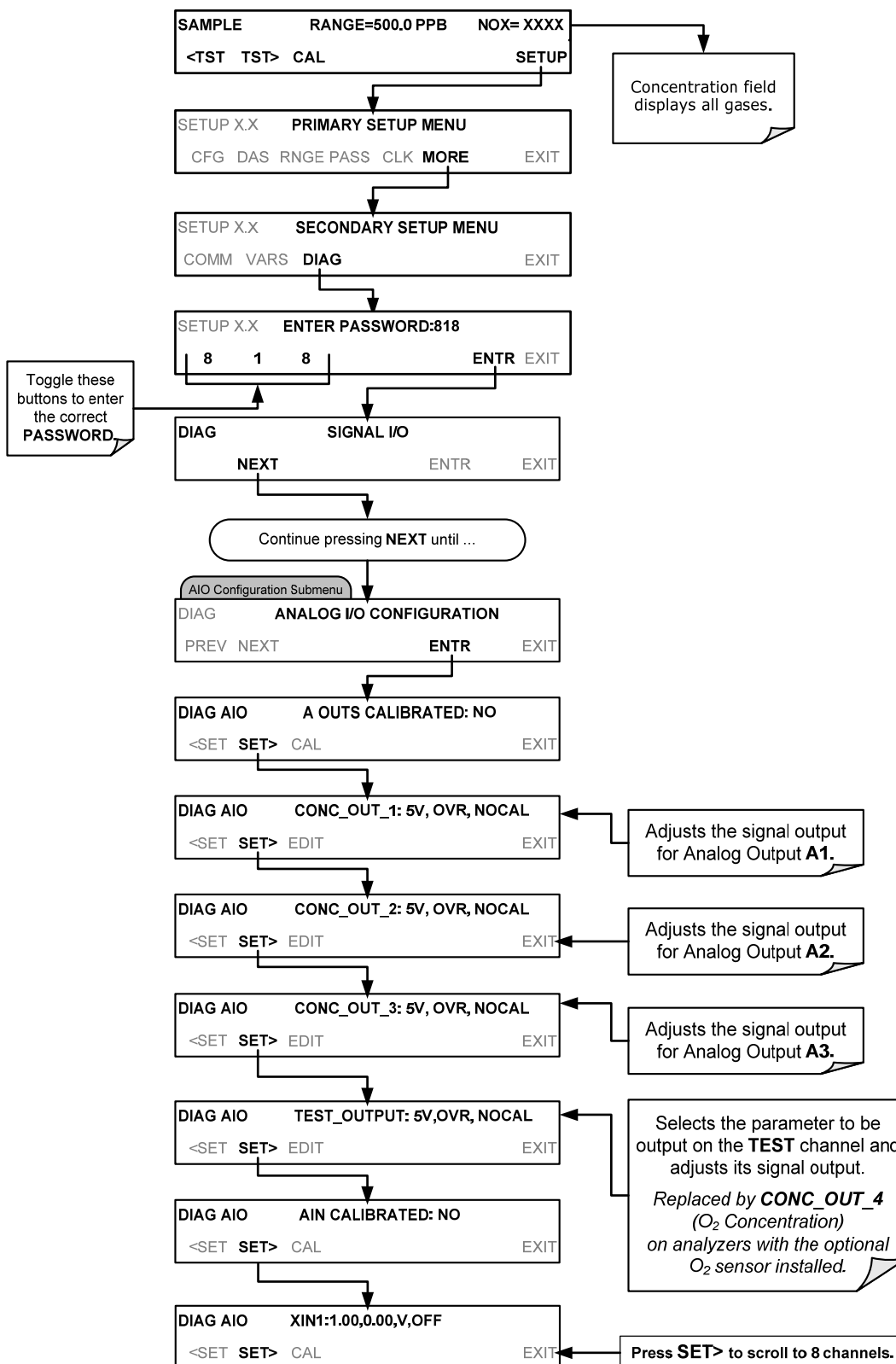

Figure 5-5: Accessing the Analog I/O Configuration Submenus

5.9.3.1. Analog Output Voltage / Current Range Selection

In its standard configuration the analog outputs is set to output a 0 – 5 VDC signals. Several other output ranges are available (see Table 5-6). Each range is usable from -5% to +5% of the rated span.

Table 5-6: Analog Output Voltage Range Min/Max

RANGE NAME	RANGE SPAN	MINIMUM OUTPUT	MAXIMUM OUTPUT
0.1V	0-100 mVDC	-5 mVDC	105 mVDC
1V	0-1 VDC	-0.05 VDC	1.05 VDC
5V	0-5 VDC	-0.25 VDC	5.25 VDC
10V	0-10 VDC	-0.5 VDC	10.5 VDC

The default offset for all VDC ranges is 0-5 VDC.

CURR	0-20 mA	0 mA	20 mA
------	---------	------	-------

While these are the physical limits of the current loop modules, typical applications use 2-20 mA or 4-20 mA for the lower and upper limits. Please specify desired range when ordering this option.
The default offset for all current ranges is 0 mA.

To change the output type and range, select the **ANALOG I/O CONFIGURATION** submenu (see Figure 5-5) then press:

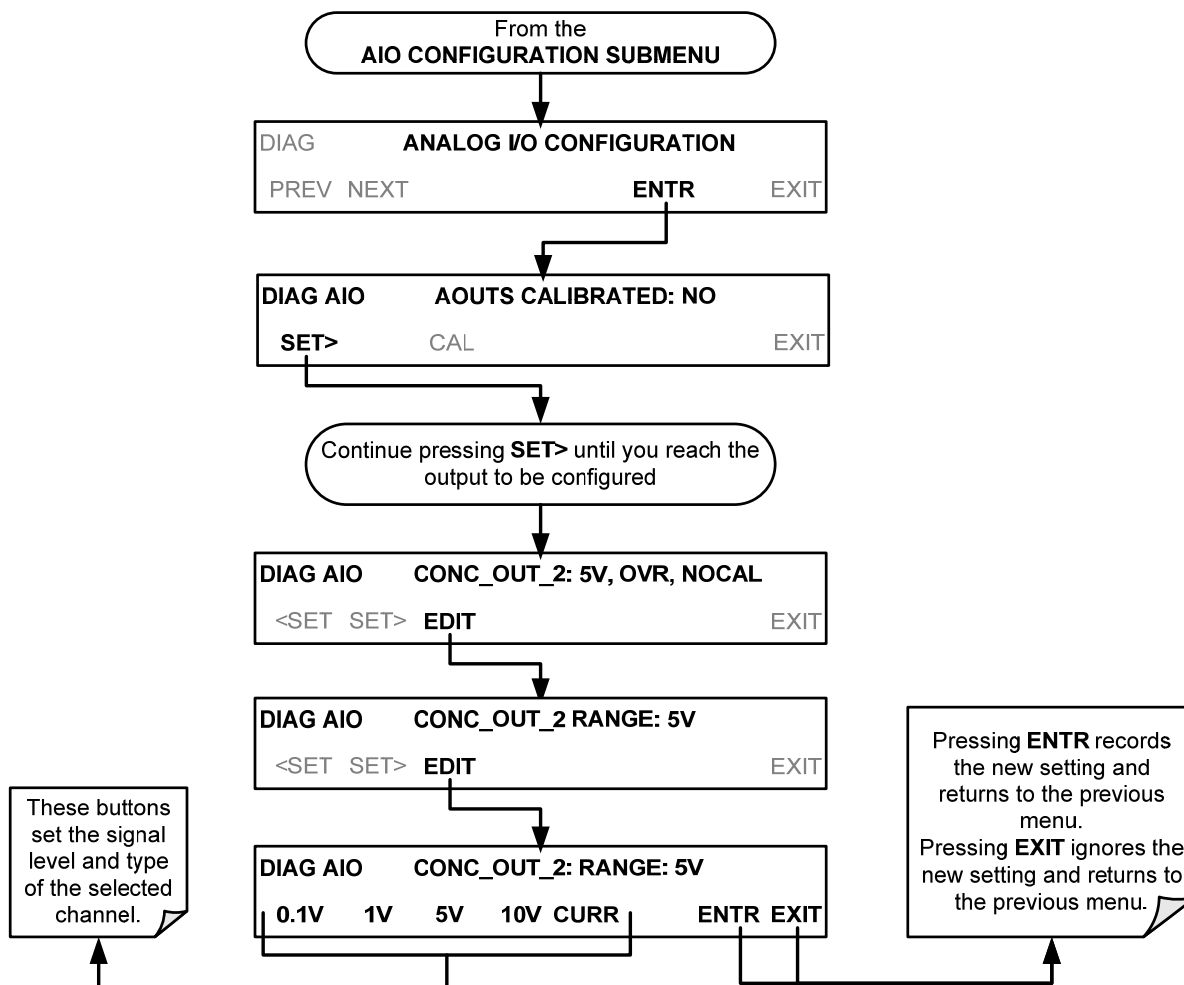

5.9.3.2. Calibration of the Analog Outputs

Analog output calibration should be carried out on first startup of the analyzer (performed in the factory as part of the configuration process) or whenever recalibration is required. The analog outputs can be calibrated automatically, either as a group or individually, or adjusted manually.

In its default mode, the instrument is configured for automatic calibration of all channels, which is useful for clearing any analog calibration warnings associated with channels that will not be used or connected to any input or recording device, e.g., data logger.

Manual calibration should be used for the 0.1V range or in cases where the outputs must be closely matched to the characteristics of the recording device. The AUTOCAL feature must be disabled first for manual calibration.

5.9.3.3. Enabling or Disabling the AutoCal for an Individual Analog Output

To enable or disable the **AutoCal** feature for an individual analog output, elect the **ANALOG I/O CONFIGURATION** submenu (see Figure 5-5) then press:

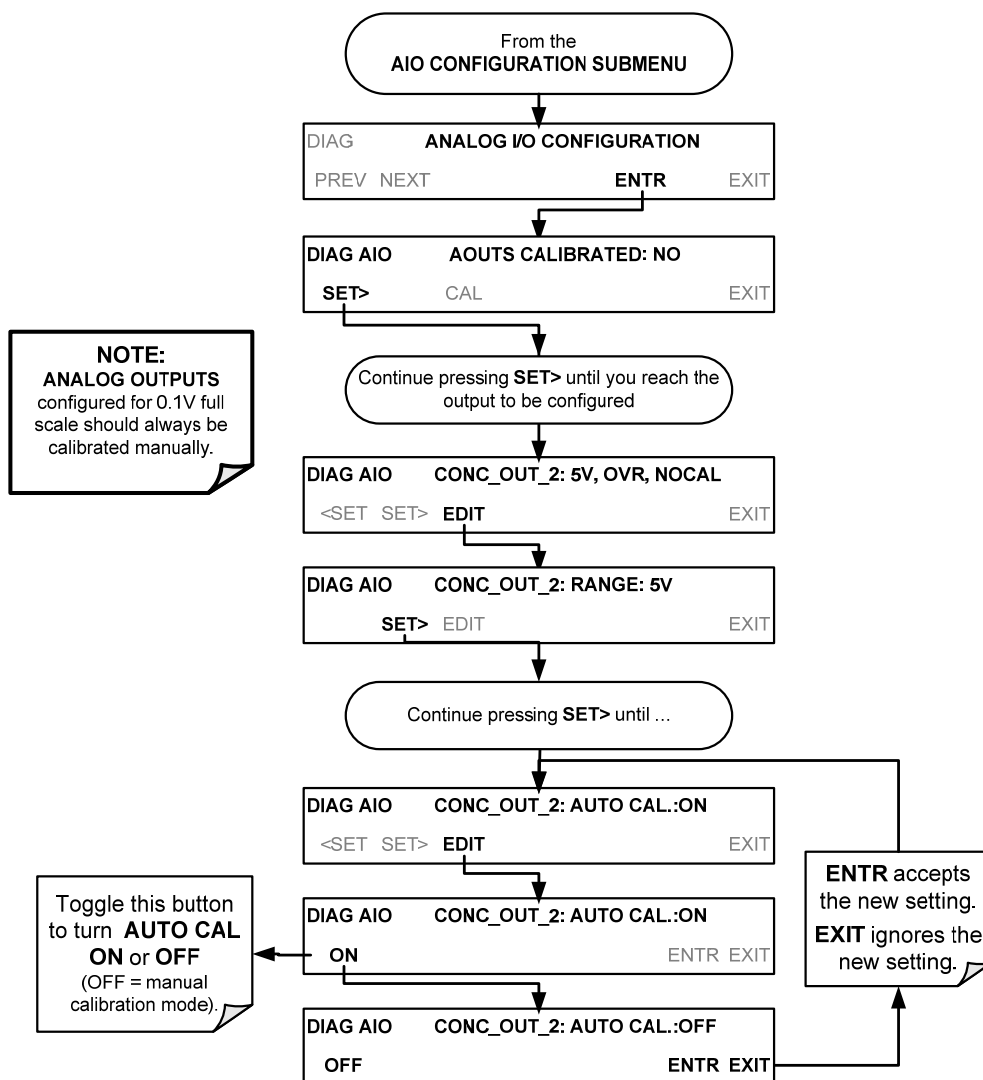

5.9.3.4. Automatic Group Calibration of the Analog Outputs

IMPORTANT

IMPACT ON READINGS OR DATA

Manual calibration should be used for any analog output set for a 0.1V output range or in cases where the outputs must be closely matched to the characteristics of the recording device. (See Sections 5.9.3.2, 5.9.3.3, and 5.9.3.6).

IMPORTANT

IMPACT ON READINGS OR DATA

Before performing this procedure, ensure that the **AUTO CAL** for each analog output is enabled. (See Section 5.9.3.3).

To calibrate the outputs as a group with the **AOUTS CALIBRATION** command, select the **ANALOG I/O CONFIGURATION** submenu (see Figure 5-5) then press:

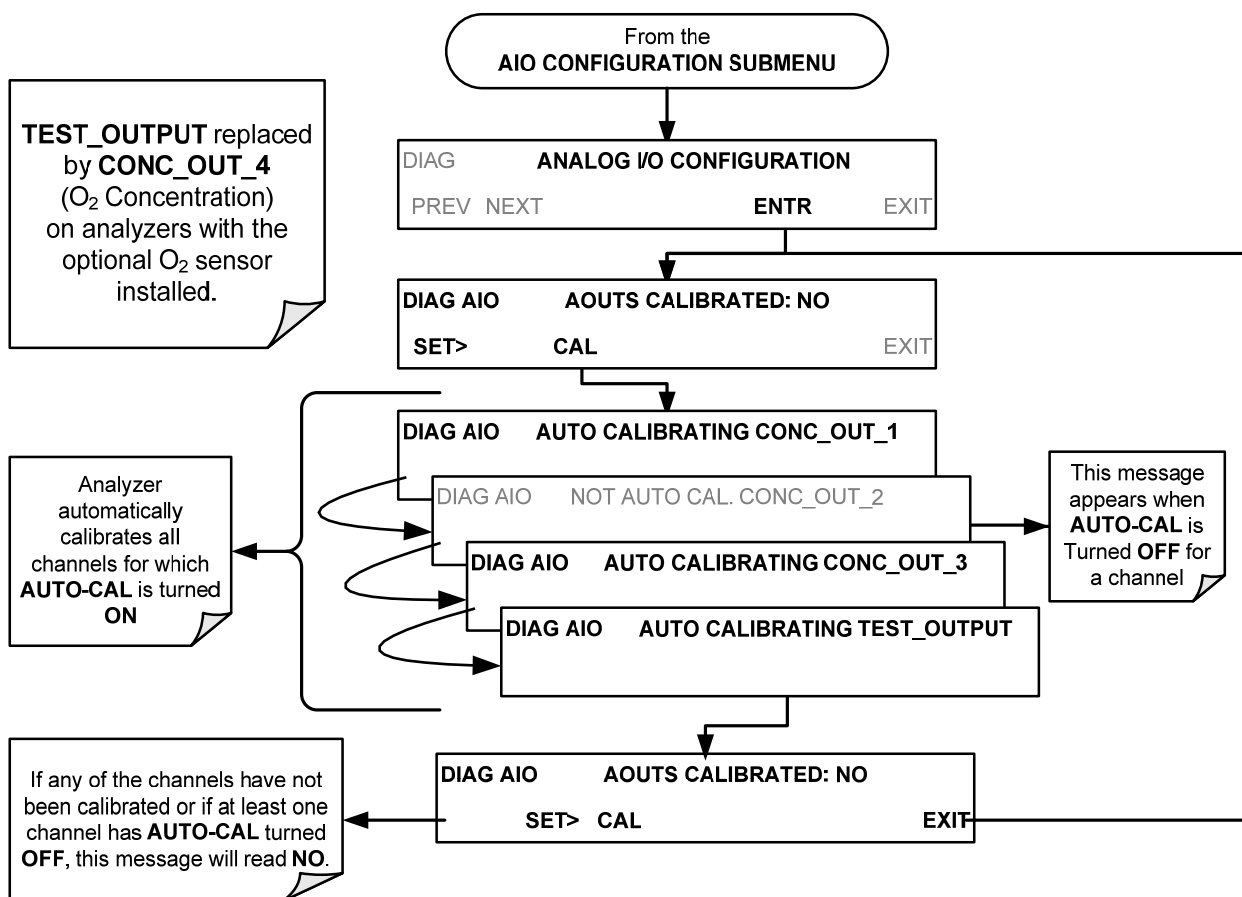

5.9.3.5. Automatic Individual Calibration of the Analog Outputs

To use the **AUTO CAL** feature to initiate an automatic calibration for an individual analog output, select the **ANALOG I/O CONFIGURATION** submenu (see Figure 5-5) then press:

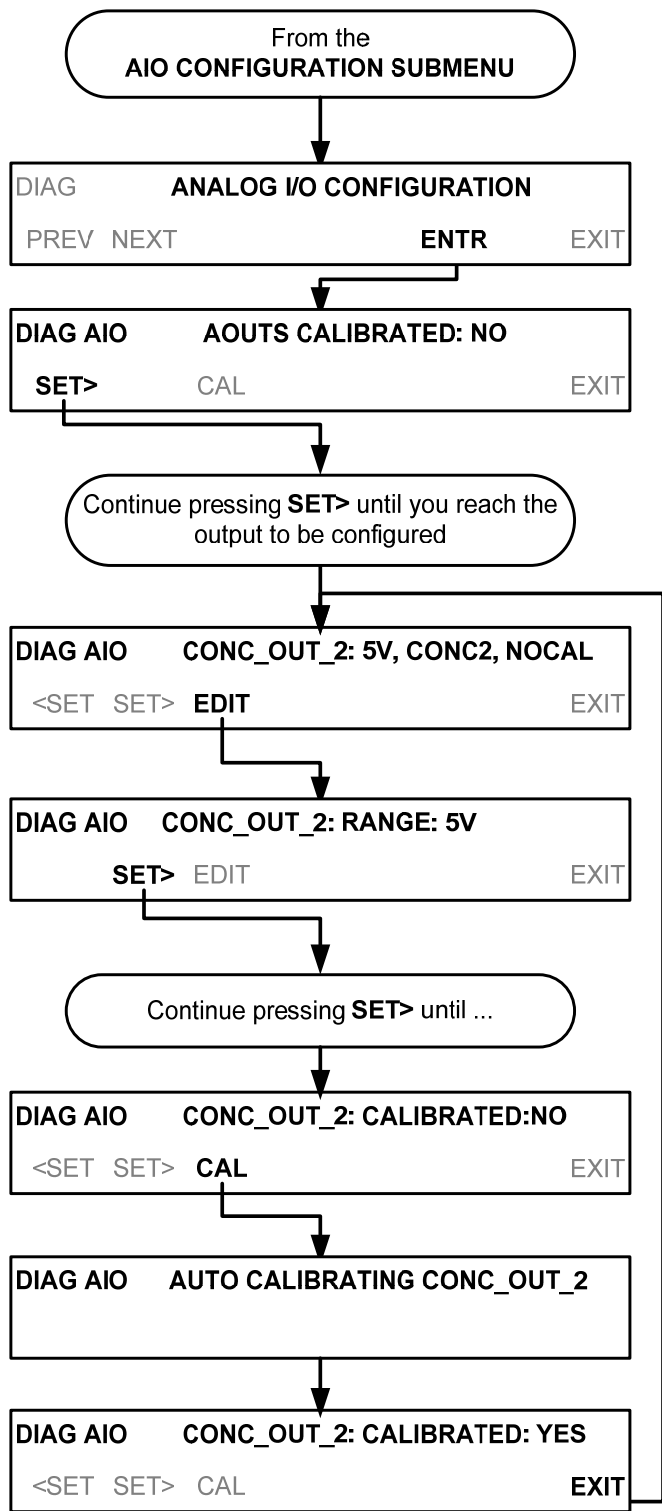

5.9.3.6. Manual Calibration of the Analog Outputs Configured for Voltage Ranges

For highest accuracy, the voltages of the analog outputs can be manually calibrated.

Note

The menu for manually adjusting the analog output signal level will only appear if the AUTO-CAL feature is turned off for the channel being adjusted. (See Section 5.9.3.3).

Calibration is performed with a voltmeter connected across the output terminals and by changing the actual output signal level using the front panel buttons in 100, 10 or 1 count increments. See Figure 3-8 for pin assignments and diagram of the analog output connector.

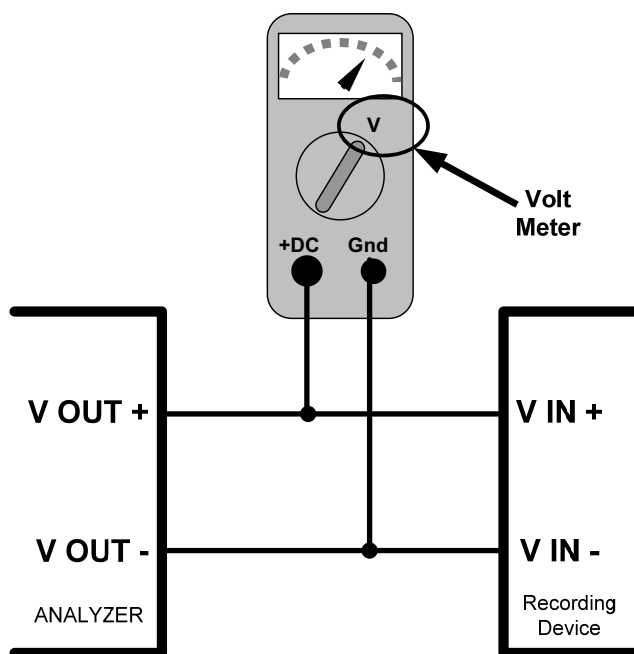
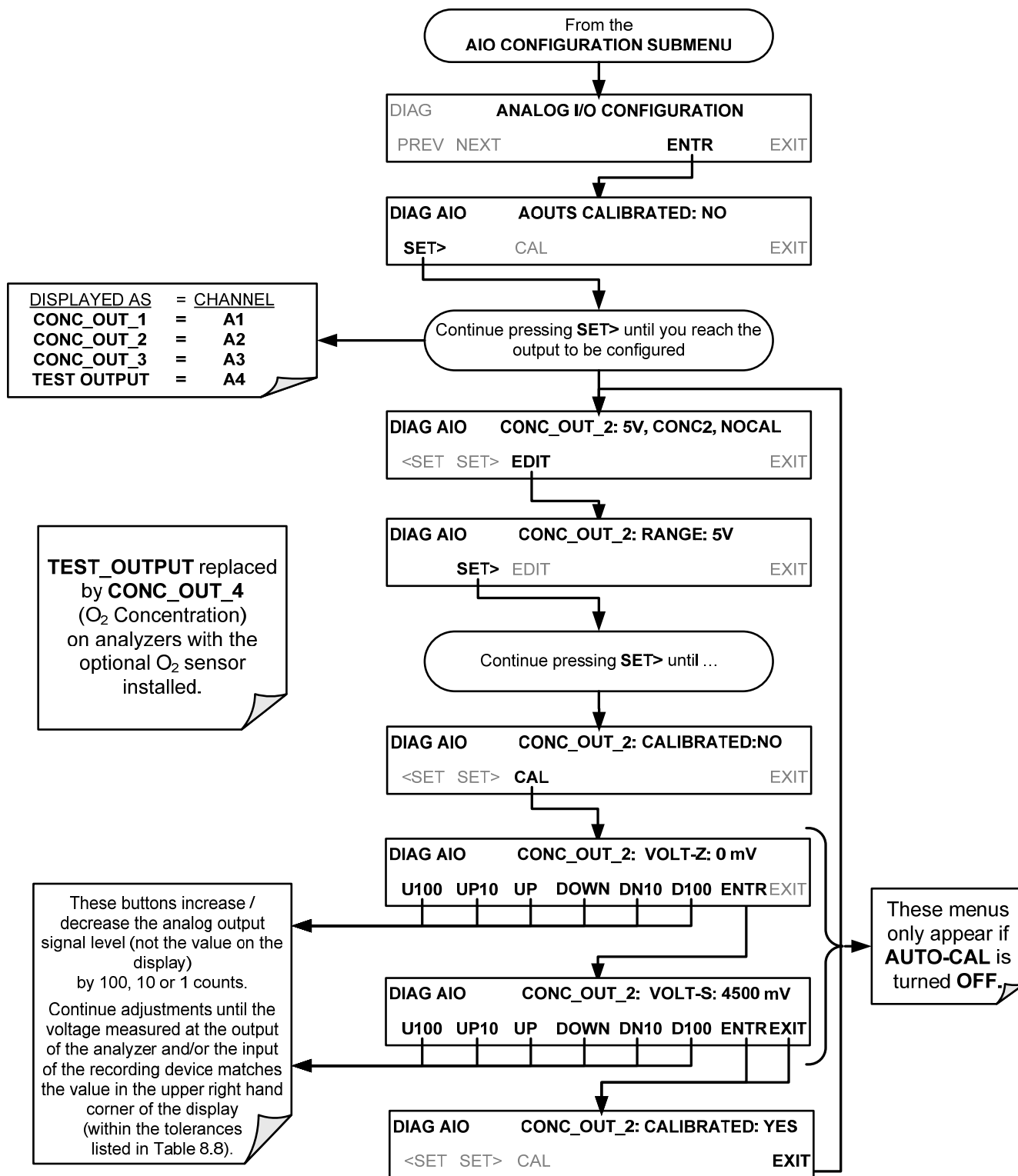

Figure 5-6: Setup for Checking / Calibrating DCV Analog Output Signal Levels

Table 5-7: Voltage Tolerances for the TEST CHANNEL Calibration

FULL SCALE	ZERO TOLERANCE	SPAN VOLTAGE	SPAN TOLERANCE	MINIMUM ADJUSTMENT (1 count)
0.1 VDC	±0.0005V	90 mV	±0.001V	0.02 mV
1 VDC	±0.001V	900 mV	±0.001V	0.24 mV
5 VDC	±0.002V	4500 mV	±0.003V	1.22 mV
10 VDC	±0.004V	4500 mV	±0.006V	2.44 mV

To adjust the signal levels of an analog output channel manually, select the **ANALOG I/O CONFIGURATION** submenu (see Figure 5-5) then press:



5.9.3.7. Manual Adjustment of Current Loop Output Span and Offset

A current loop option may be purchased for the **A1**, **A2** and **A3** Analog outputs of the analyzer. This option places circuitry in series with the output of the D-to-A converter on the motherboard that changes the normal DC voltage output to a 0-20 milliamp signal (See Section 3.3.1.4).

1. The outputs can be ordered scaled to any set of limits within that 0-20 mA range, however most current loop applications call for either 0-20 mA or 4-20 mA range spans.
2. All current loop outputs have a +5% over range. Ranges whose lower limit is set above 1 mA also have a -5% under range.

To switch an analog output from voltage to current loop, follow the instructions in Section 5.9.3.1 (select **CURR** from the list of options on the “Output Range” menu).

Adjusting the signal zero and span levels of the current loop output is done by raising or lowering the voltage output of the D-to-A converter circuitry on the analyzer’s motherboard. This raises or lowers the signal level produced by the current loop option circuitry.

The software allows this adjustment to be made in 100, 10 or 1 count increments. Since the exact amount by which the current signal is changed per D-to-A count varies from output-to-output and instrument-to-instrument, you will need to measure the change in the signal levels with a separate, current meter placed in series with the output circuit. See Figure 3-8 for pin assignments and diagram of the analog output connector.

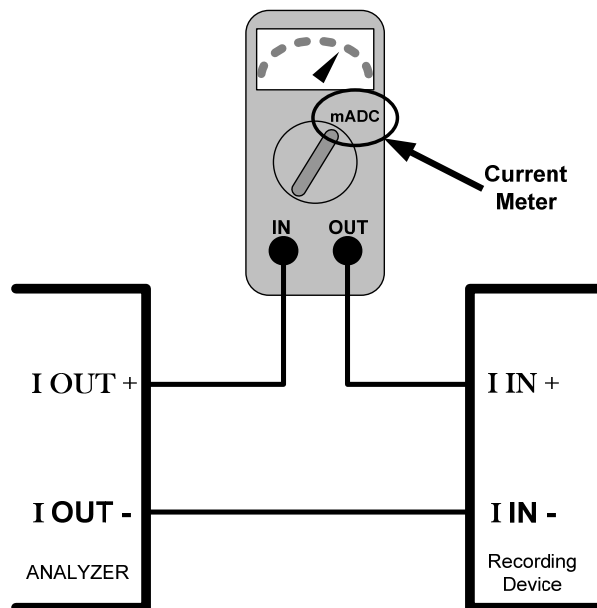

Figure 5-7: Setup for Checking / Calibration Current Output Signal Levels Using an Ammeter



CAUTION – GENERAL SAFETY HAZARD

Do not exceed 60 V peak voltage between current loop outputs and instrument ground.

To adjust the zero and span signal levels of the current outputs, select the **ANALOG I/O CONFIGURATION** submenu (see Figure 5-5) then press:

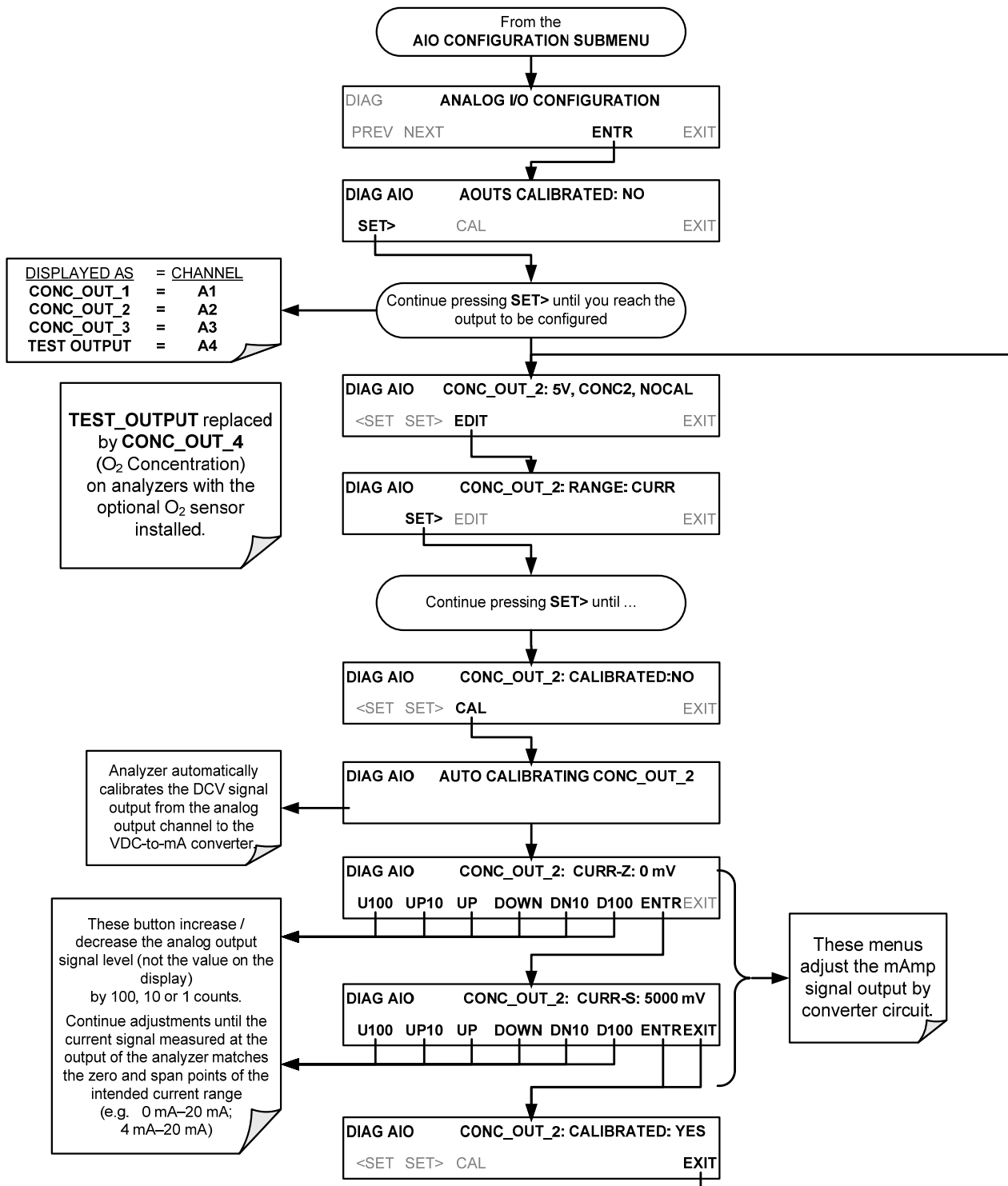

An alternate method for measuring the output of the Current Loop converter is to connect a 250 ohm $\pm 1\%$ resistor across the current loop output in lieu of the current meter (see Figure 3-8 for pin assignments and diagram of the analog output connector). This allows the use of a voltmeter connected across the resistor to measure converter output as VDC or mVDC.

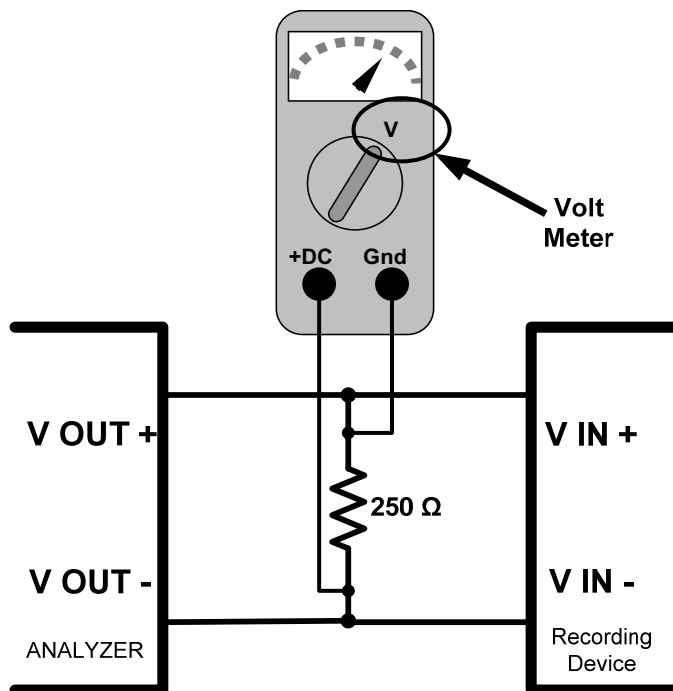

Figure 5-8: Alternative Setup Using 250Ω Resistor for Checking Current Output Signal Levels

In this case, follow the procedure above but adjust the output for the following values:

Table 5-8: Current Loop Output Check

% FS	Voltage across Resistor for 2-20 mA	Voltage across Resistor for 4-20 mA
0	500 mVDC	1000 mVDC
100	5000 mVDC	5000 mVDC

5.9.3.8. TURNING AN ANALOG OUTPUT OVER-RANGE FEATURE ON/OFF

In its default configuration, a $\pm 5\%$ over-range is available on each of the 9110T's analog outputs. This over-range can be disabled if your recording device is sensitive to excess voltage or current.

To turn the over-range feature on or off, select the **ANALOG I/O CONFIGURATION** submenu (see Figure 5-5) then press:

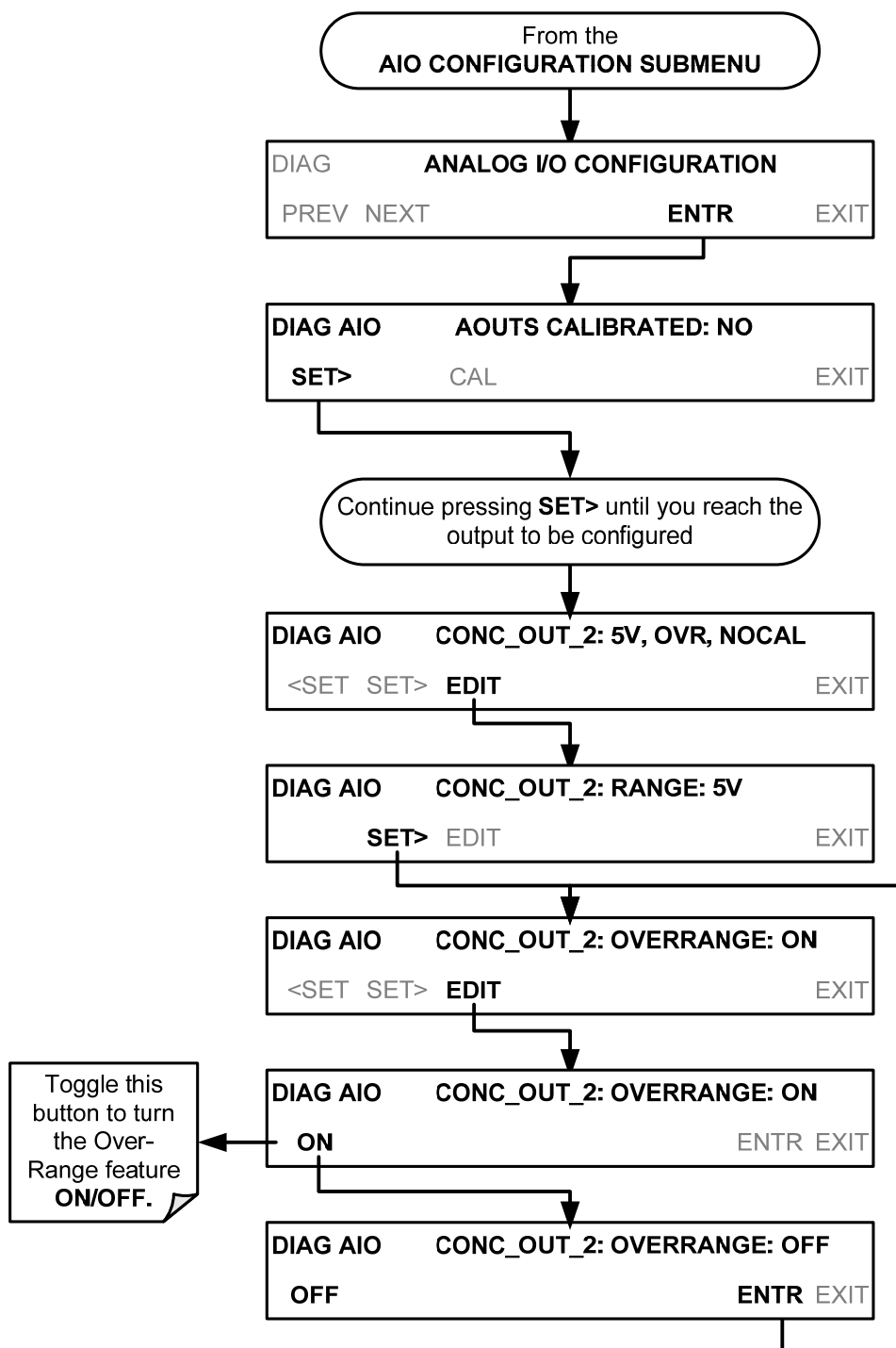

5.9.3.9. ADDING A RECORDER OFFSET TO AN ANALOG OUTPUT

Some analog signal recorders require that the zero signal be significantly different from the baseline of the recorder in order to record slightly negative readings from noise around the zero point. This can be achieved in the 9110T by defining a zero offset, a small voltage (e.g., 10% of span).

To add a zero offset to a specific analog output channel, select the **ANALOG I/O CONFIGURATION** submenu (see Figure 5-5) then press:

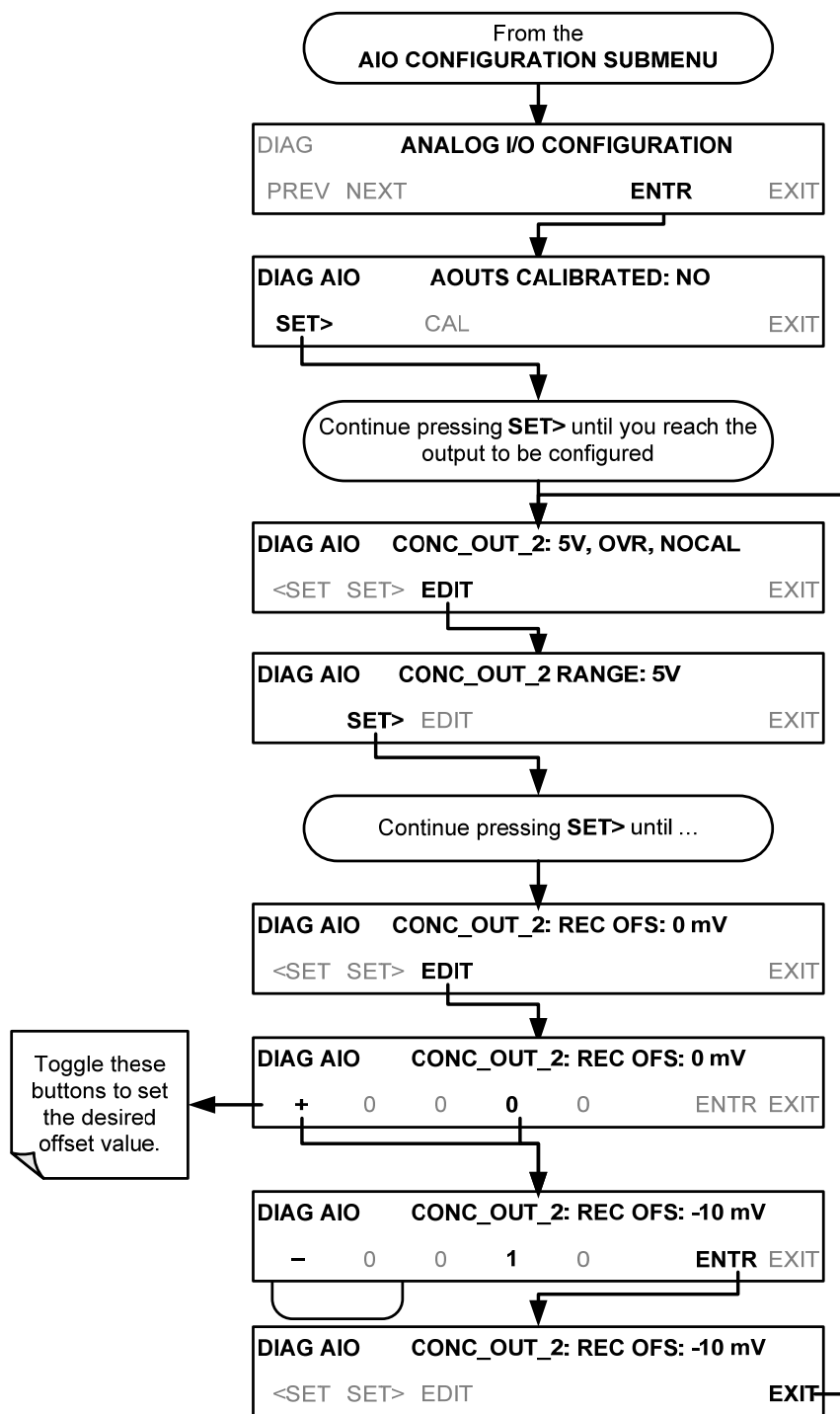

5.9.3.10. AIN Calibration

This is the submenu to conduct a calibration of the 9110T analyzer’s analog inputs. This calibration should only be necessary after major repair such as a replacement of CPU, motherboard or power supplies.

To perform an analog input calibration, select the **ANALOG I/O CONFIGURATION** submenu (see Figure 5-5) then press:

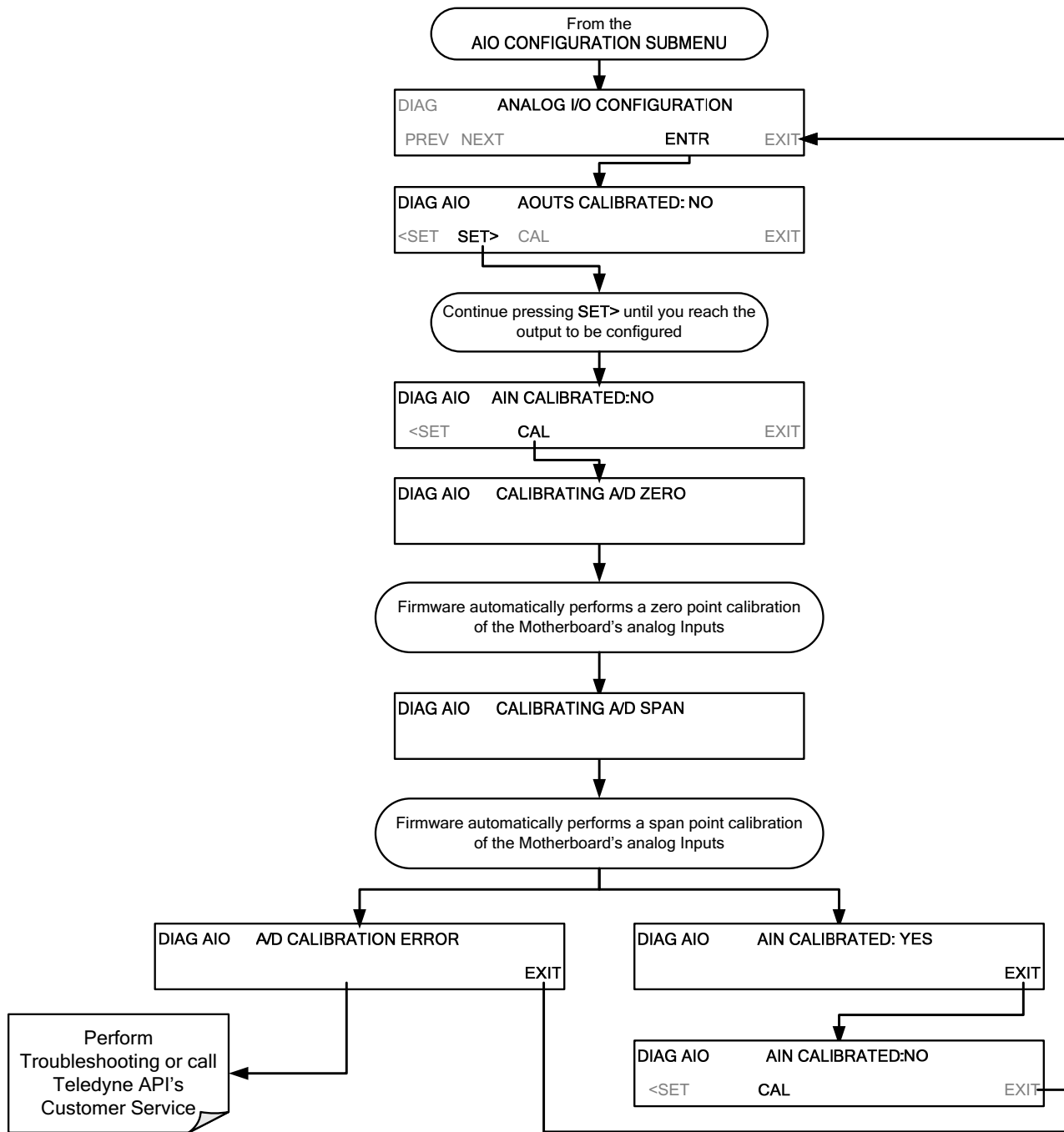

5.9.3.11. External Analog Inputs (XIN1...XIN8) Option Configuration

To configure the analyzer’s optional external analog inputs, define for each channel:

- gain (number of units represented by 1 volt)
- offset (volts)
- engineering units to be represented in volts (each press of the touchscreen button scrolls the list of alphanumeric characters from A-Z and 0-9)
- whether to display the channel in the Test functions

These parameters can also be captured in the internal Data Acquisition System (DAS); refer to Appendix A for Analog-In DAS parameters.

To adjust settings for the Analog Inputs option parameters press:

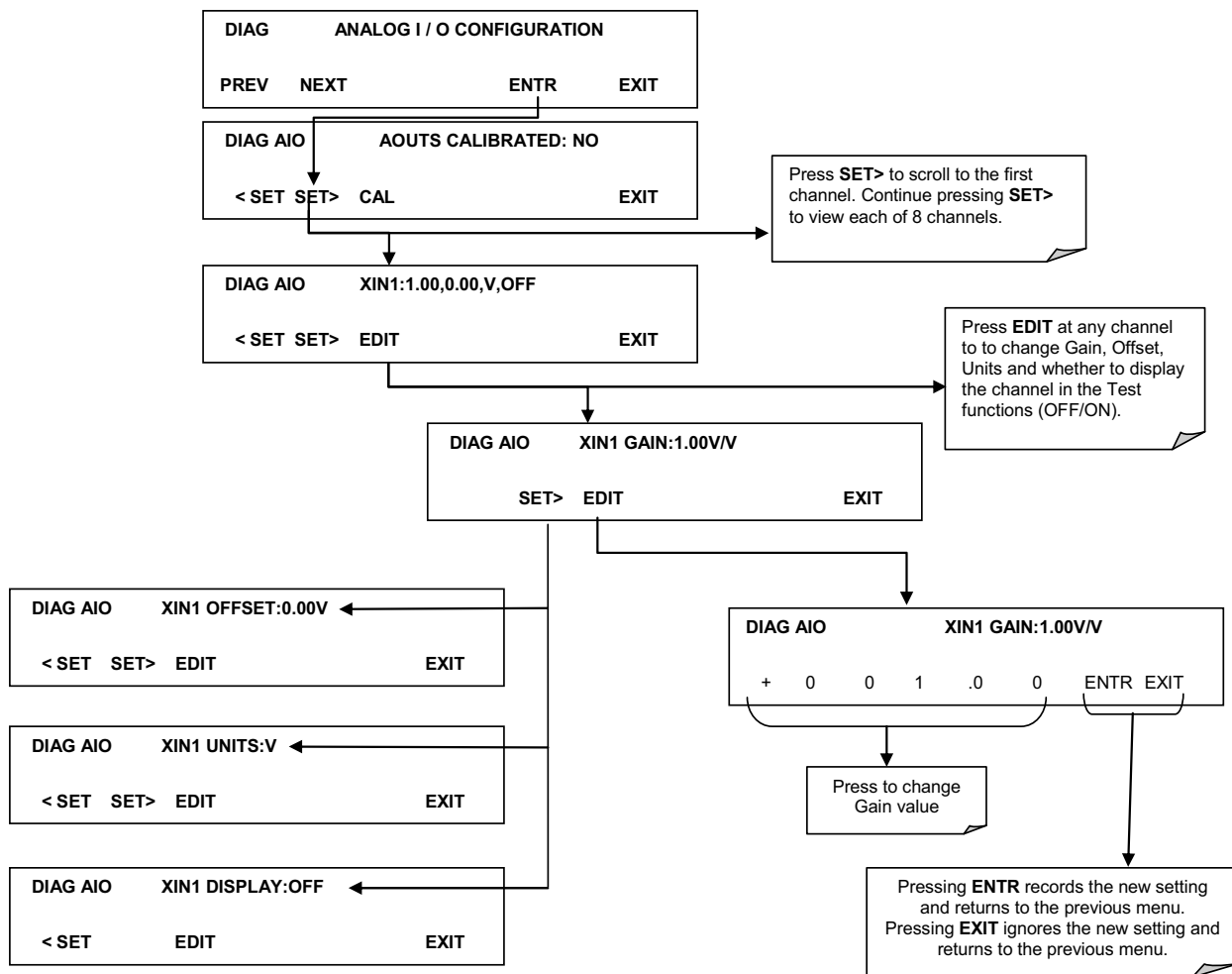

5.9.4. TEST CHAN OUTPUT (SELECTING A TEST CHANNEL FUNCTION FOR OUTPUT A4)

The test functions available to be reported are listed in Table 5-9:

Table 5-9: Test Channels Functions available on the 9110T's Analog Output

TEST CHANNEL	DESCRIPTION	ZERO	FULL SCALE
NONE	<i>TEST CHANNEL IS TURNED OFF</i>		
PMT DETECTOR	The output of the PMT detector converted to a 0 to 5 VDC scale.	0 mV	5000 mV ¹
OZONE FLOW	The flow rate of O ₃ through the analyzer as measured by the O ₃ flow sensor.	0 cm ³ /min	1000 cm ³ /min
SAMPLE FLOW	The calculated flow rate for sample gas through the analyzer.	0 cm ³ /min	1000 cm ³ /min
SAMPLE PRESSURE	The pressure of the sample gas measured upstream of the Auto Zero Valve.	0 Hg-In-A	40 "Hg-In-A
RCELL PRESSURE	The pressure of gas inside the reaction cell of the sensor module.	0 Hg-In-A	40 Hg-In-A
RCELL TEMP	The temperature of gas inside the reaction cell of the sensor module.	0 °C	70 °C
MANIFOLD TEMP	Not used in the Model 9110T.		
IZS TEMP	The temperature of the permeation tube oven of the optional internal span gas generator.	0 °C	70 °C
CONV TEMP	The temperature NO ₂ → NO converter.	0 °C	500 °C
PMT TEMP	The temperature inside PMT.	0 °C	50 °C
BOX TEMP	The temperature inside the 9110T's chassis.	0 °C	70 °C
HVPS VOLTAGE	Represents the output voltage of the PMT's high voltage power supply.	0 mV	5000 mV ¹

Once a function is selected, the instrument not only begins to output a signal on the analog output, but also adds **TEST** to the list of test functions viewable via the front panel display.

To activate the TEST Channel and select a function, press:

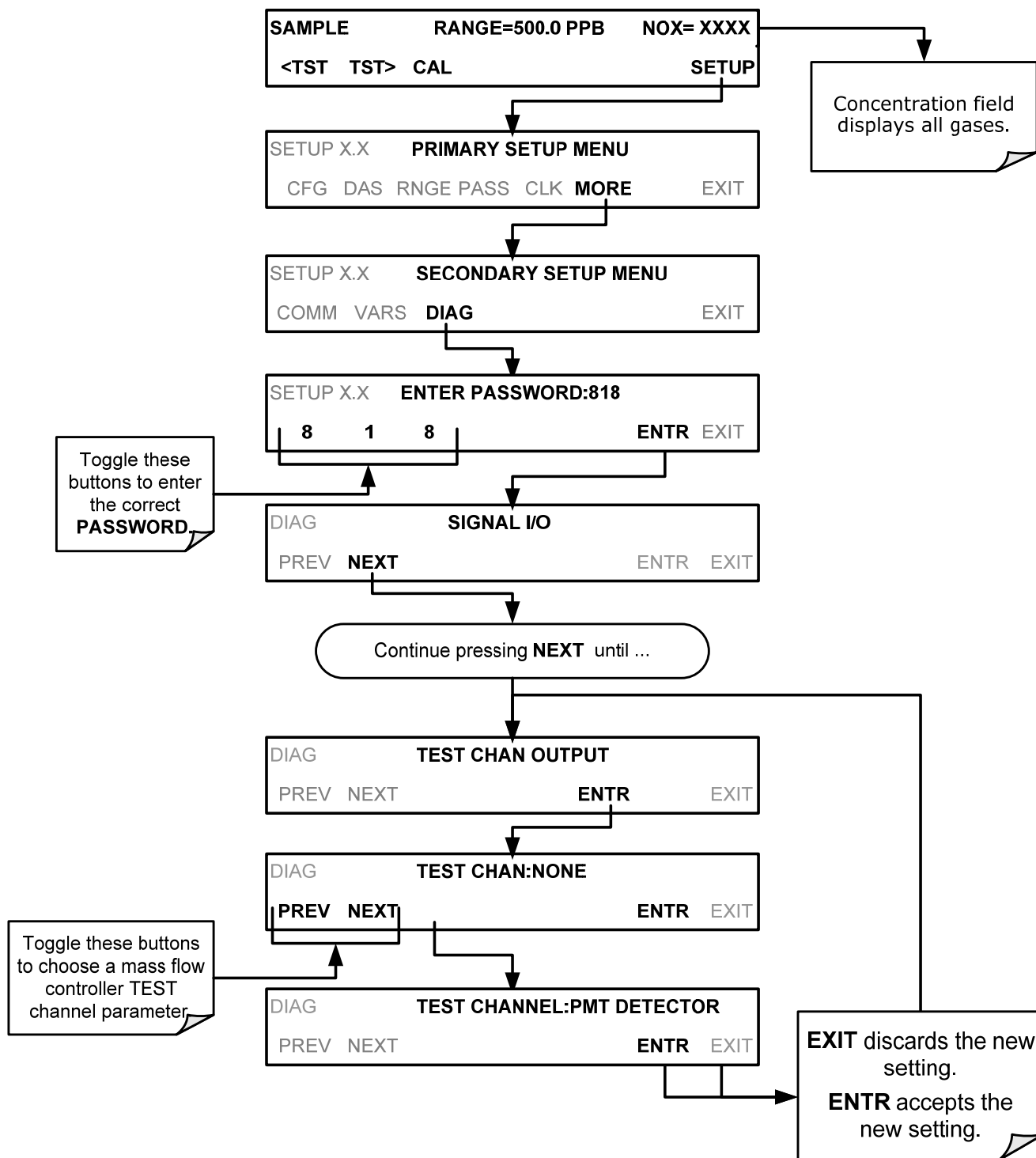

5.9.5. OPTIC TEST

The OPTIC TEST function tests the response of the PMT sensor by turning on an LED located in the cooling block of the PMT. The analyzer uses the light emitted from the LED to test its photo-electronic subsystem, including the PMT and the current to voltage converter on the pre-amplifier board. To ensure

that the analyzer measures only the light coming from the LED, the analyzer should be supplied with zero air. The optic test should produce a PMT signal of about 2000 ± 1000 mV.

Section 12.7.12.1 presents instructions for use in troubleshooting and service.

IMPORTANT**IMPACT ON READINGS OR DATA**

This is a coarse test for functionality and not an accurate calibration tool. The resulting PMT signal can vary significantly over time and also changes with low-level calibration.

5.9.6. ELECTRICAL TEST

The ELECTRICAL TEST function creates a current, which substitutes the PMT signal, and feeds it into the preamplifier board. This signal is generated by circuitry on the pre-amplifier board itself and tests the filtering and amplification functions of that assembly along with the A/D converter on the motherboard. It does not test the PMT itself. The electrical test should produce a PMT signal of about 2000 ± 1000 mV.

Section 12.7.12.2 presents instructions for use in troubleshooting and service.

5.9.7. OZONE GEN OVERRIDE

This feature is used to manually turn the ozone generator off and on. Read Section 13.2.3 to understand the ozone generator, and refer to Section 12.7.15.1 for instructions on using the override feature in troubleshooting and service.

5.9.8. FLOW CALIBRATION

This function is used to calibrate the gas flow output signals of sample gas and ozone supply. Section 9.7 presents instructions for flow calibration. Used to adjust the gas flow calculations made by the CPU based on pressure and flow sensor readings.

6. COMMUNICATIONS SETUP AND OPERATION

This instrument's rear panel connections include an Ethernet port, a USB port (option) and two serial communications ports labeled **RS232**, which is the COM1 port, and **COM2** (refer to Figure 3-4). These ports give the user the ability to communicate with, issue commands to, and receive data from the analyzer through an external computer system or terminal. Connection instructions were provided in Section 3.3.1.8.

This section provides pertinent information regarding communication equipment, describes the instrument's communications modes, presents configuration instructions for the communications ports, and provides instructions for their use, including communications protocol. Data acquisition is presented in Section 7.

6.1. DATA TERMINAL / COMMUNICATION EQUIPMENT (DTE DEC)

RS-232 was developed for allowing communications between data terminal equipment (DTE) and data communication equipment (DCE). Basic terminals always fall into the DTE category whereas modems are always considered DCE devices. The difference between the two is the pin assignment of the Data Receive and Data Transmit functions.

- DTE devices receive data on pin 2 and transmit data on pin 3.
- DCE devices receive data on pin 3 and transmit data on pin 2.

To allow the analyzer to be used with terminals (DTE), modems (DCE) and computers (which can be either), a switch mounted below the serial ports on the rear panel labeled **DCE DTE** (Figure 3-4) allows the user to set the RS-232 configuration for one of these two data devices. This switch exchanges the Receive and Transmit lines on RS-232 emulating a cross-over or null-modem cable. The switch has no effect on COM2.

6.2. COMMUNICATION MODES, BAUD RATE AND PORT TESTING

Use the SETUP>MORE>COMM menu to configure COM1 (labeled **RS232** on instrument rear panel) and/or COM2 (labeled **COM2** on instrument rear panel) for communication modes, baud rate and/or port testing for correct connection. If using a USB option communication connection, setup requires configuring the COM2 baud rate (Section 6.2.2).

6.2.1. COMMUNICATION MODES

Each of the analyzer's serial ports can be configured to operate in a number of different modes, listed in Table 6-1. As modes are selected, the analyzer sums the mode ID numbers and displays this combined number on the front panel display. For example, if quiet mode (01), computer mode (02) and Multi-Drop-Enabled mode (32) are selected, the analyzer would display a combined **MODE ID** of 35.

Table 6-1: COMM Port Communication Modes

MODE ¹	ID	DESCRIPTION
QUIET	1	Quiet mode suppresses any feedback from the analyzer (such as warning messages) to the remote device and is typically used when the port is communicating with a computer program where such intermittent messages might cause communication

		problems. Such feedback is still available but a command must be issued to receive them.
COMPUTER	2	Computer mode inhibits echoing of typed characters and is used when the port is communicating with a computer operated control program.
TAI PROTOCOL	16384	Protocol for communication with TAI Valve Boxes.
E, 8, 1	8192	When turned on this mode switches the COMM port settings from No parity; 8 data bits; 1 stop bit to Even parity; 8 data bits; 1 stop bit.
E, 7, 1	2048	When turned on this mode switches the COMM port settings from No parity; 8 data bits; 1 stop bit to Even parity; 7 data bits; 1 stop bit.
RS-485	1024	Configures the COM2 Port for RS-485 communication. RS-485 mode has precedence over multidrop mode if both are enabled. Also, configuring for RS-485 disables the rear panel USB port.
SECURITY	4	When enabled, the serial port requires a password before it will respond (see Section 5.5). The only command that is active is the help screen (? CR).
MULTIDROP PROTOCOL	32	Multidrop protocol allows a multi-instrument configuration on a single communications channel. Multidrop requires the use of instrument IDs.
ENABLE MODEM	64	Enables to send a modem initialization string at power-up. Asserts certain lines in the RS-232 port to enable the modem to communicate.
ERROR CHECKING²	128	Fixes certain types of parity errors at certain installations.
XON/XOFF HANDSHAKE²	256	Disables XON/XOFF data flow control also known as software handshaking.
HARDWARE HANDSHAKE	8	Enables CTS/RTS style hardwired transmission handshaking. This style of data transmission handshaking is commonly used with modems or terminal emulation protocols as well as by Teledyne Instrument's APICOM software.
HARDWARE FIFO²	512	Disables the HARDWARE FIFO (First In – First Out). When FIFO is enabled, it improves data transfer rate for that COMM port.
COMMAND PROMPT	4096	Enables a command prompt when in terminal mode.
¹ Modes are listed in the order in which they appear in the SETUP → MORE → COMM → COM[1 OR 2] → MODE menu ² The default setting for this feature is ON . Do not disable unless so instructed by Teledyne Customer Service personnel.		

Communication Modes for each COMM port must be configured independently. To turn on or off the communication modes for either COM1 or COM2, access the **SETUP>MORE.[COM1 OR COM2]** menu, and at the COM1 [2] Mode menu press EDIT.

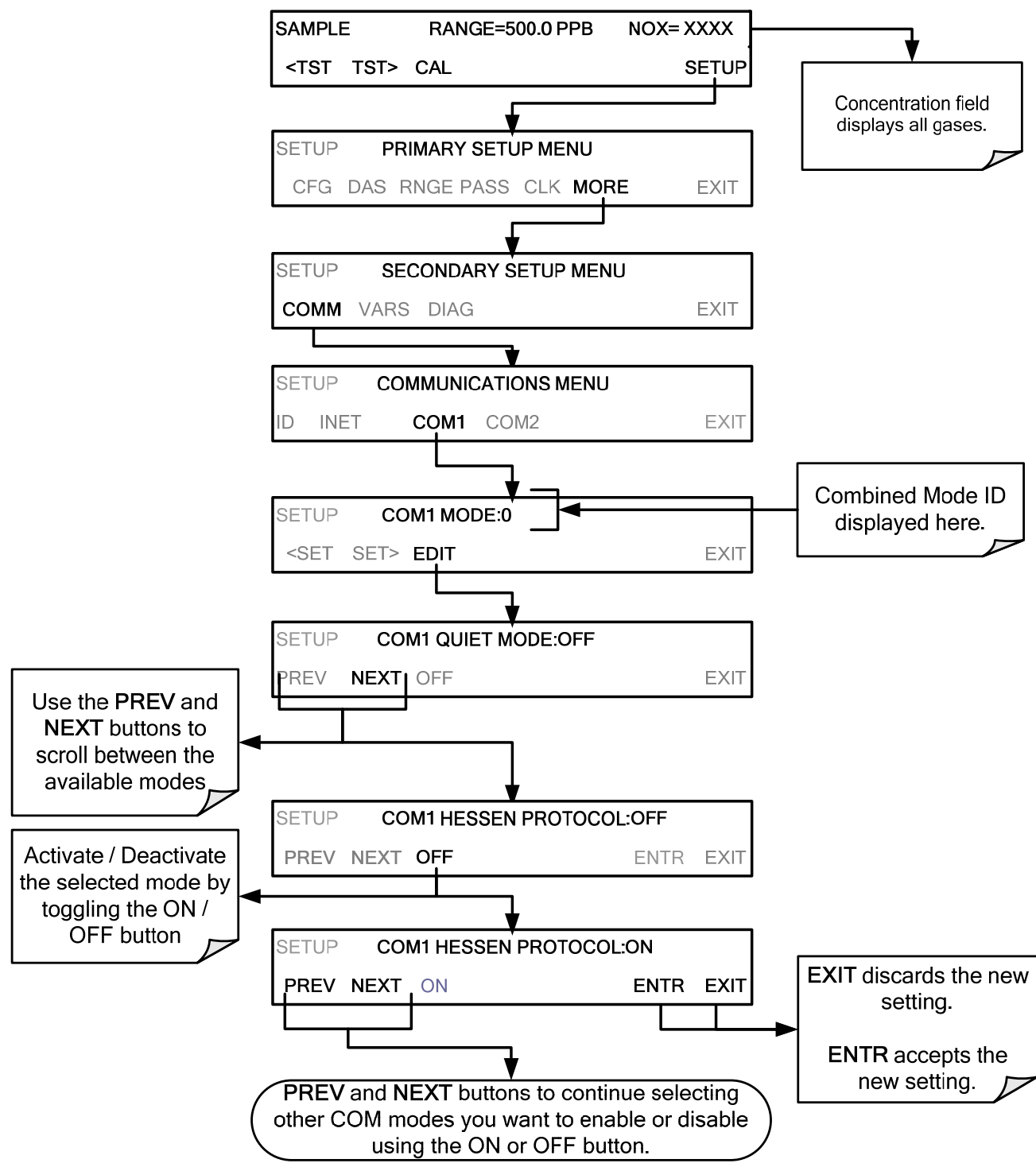

Figure 6-1. COMM – Communication Modes Setup

6.2.2. COM PORT BAUD RATE

To select the baud rate of either COMM Port, go to SETUP>MORE>COMM and select either COM1 or COM2 as follows (use COM2 to view/match your personal computer baud rate when using the USB port, Section 6.6):

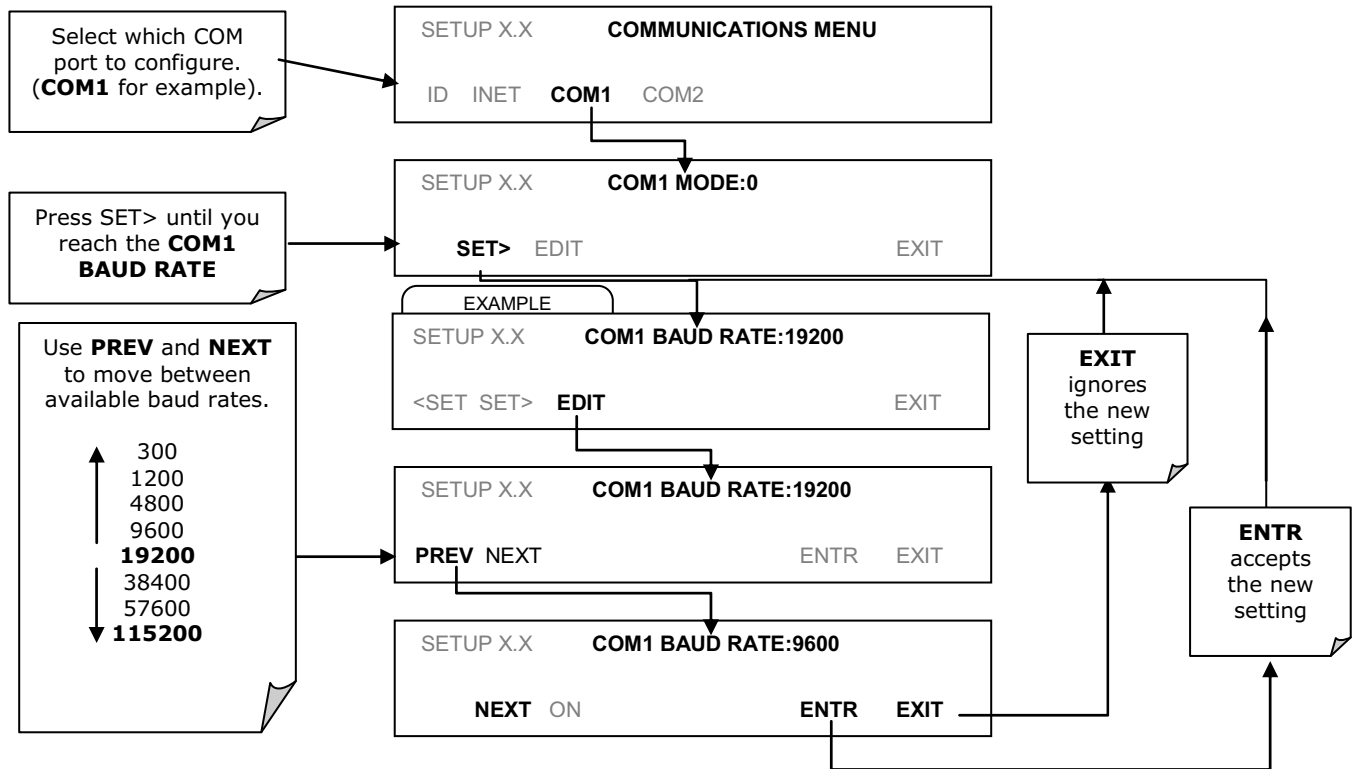

Figure 6-2. COMM – COMM Port Baud Rate

6.2.3. COM PORT TESTING

The serial ports can be tested for correct connection and output in the COMM menu. This test sends a string of 256 ‘w’ characters to the selected COMM port. While the test is running, the red LED on the rear panel of the analyzer should flicker.

To initiate the test press the following button sequence:

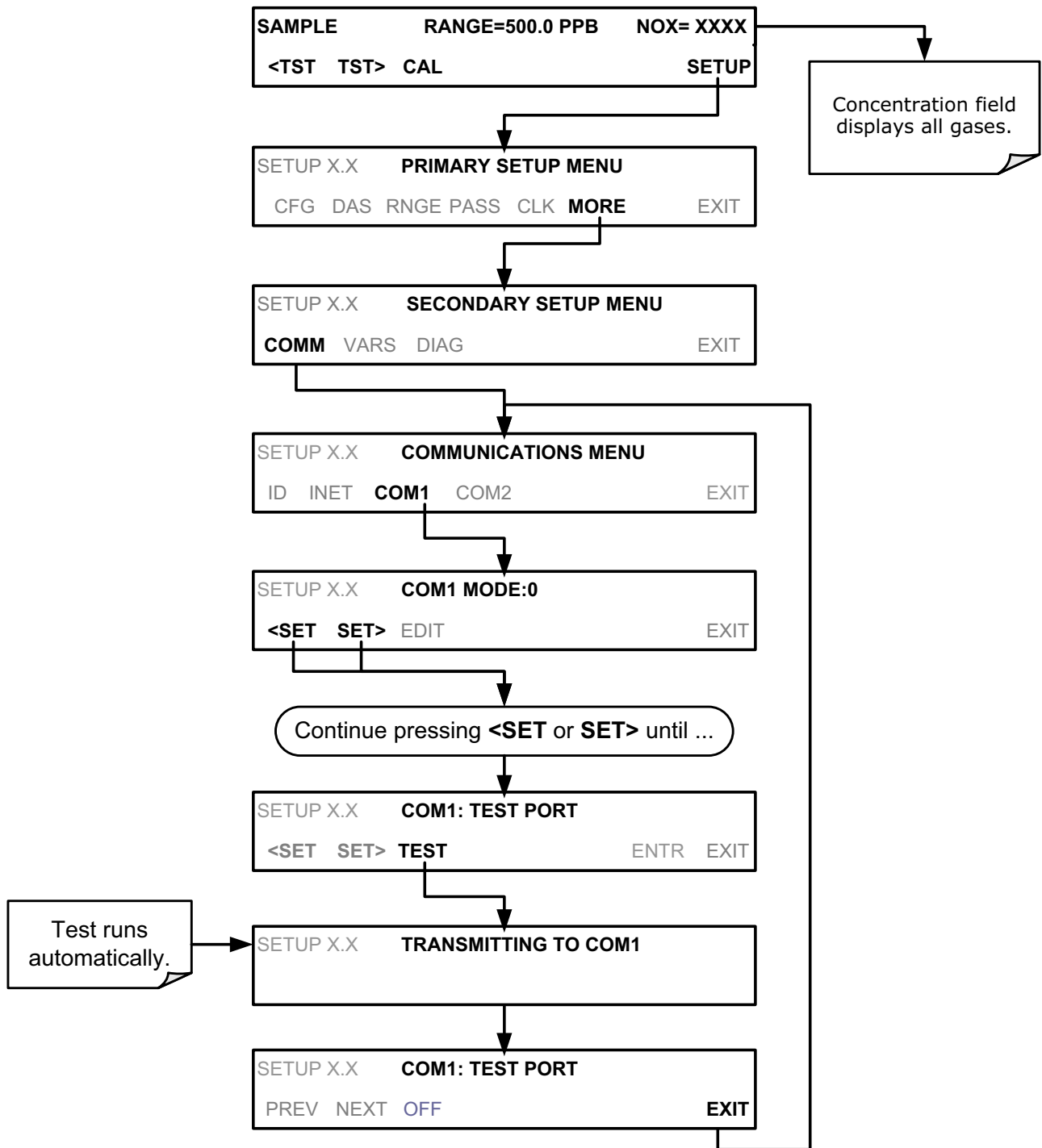

Figure 6-3. COMM – COM1 Test Port

6.3. RS-232

The RS232 and COM2 communications (COMM) ports operate on the RS-232 protocol (default configuration). Possible configurations for these two COMM ports are summarized as follows:

- **RS232** port can also be configured to operate in single or RS-232 Multidrop mode (Option 62); refer to Section 3.3.1.8.

- **COM2** port can be left in its default configuration for standard RS-232 operation including multidrop, or it can be reconfigured for half-duplex RS-485 operation (please contact the factory for this configuration).

Note that when the rear panel **COM2** port is in use, except for multidrop communication, the rear panel USB port cannot be used. (Alternatively, when the USB port is enabled, **COM2** port cannot be used except for multidrop).

A code-activated switch (CAS), can also be used on either port to connect typically between 2 and 16 send/receive instruments (host computer(s) printers, data loggers, analyzers, monitors, calibrators, etc.) into one communications hub. Contact TAI Sales for more information on CAS systems.

To configure the analyzer's communication ports, use the **SETUP>MORE>COMM** menu. Refer to Section 5.7 for initial setup, and to Section 6.2 for additional configuration information.

6.4. RS-485 (OPTION)

The COM2 port of the instrument's rear panel is set up for RS-232 communication but can be reconfigured for RS-485 communication. Contact Customer Service. If this option was elected at the time of purchase, the rear panel was preconfigured at the factory.

6.5. ETHERNET

When using the Ethernet interface, the analyzer can be connected to any standard 10BaseT or 100BaseT Ethernet network via low-cost network hubs, switches or routers. The interface operates as a standard TCP/IP device on port 3000. This allows a remote computer to connect through the network to the analyzer using APICOM, terminal emulators or other programs.

The Ethernet connector has two LEDs that are on the connector itself, indicating its current operating status.

Table 6-2: Ethernet Status Indicators

LED	FUNCTION
amber (link)	On when connection to the LAN is valid.
green (activity)	Flickers during any activity on the LAN.

The analyzer is shipped with DHCP enabled by default. This allows the instrument to be connected to a network or router with a DHCP server. The instrument will automatically be assigned an IP address by the DHCP server (Section 6.5.2). This configuration is useful for quickly getting an instrument up and running on a network. However, for permanent Ethernet connections, a static IP address should be used. Section 6.5.1 below details how to configure the instrument with a static IP address.

6.5.1. CONFIGURING ETHERNET COMMUNICATION MANUALLY (STATIC IP ADDRESS)

To configure Ethernet communication manually:

1. Connect a cable from the analyzer's Ethernet port to a Local Area Network (LAN) or Internet port.

From the analyzer's front panel touchscreen, access the Communications Menu (SETUP>MORE>COMM,

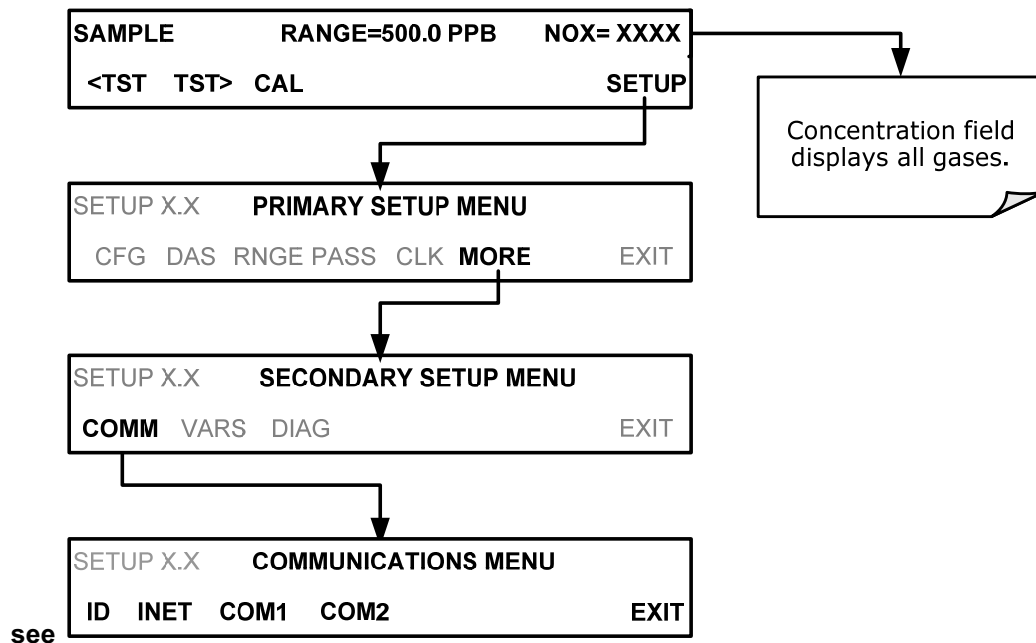

2. Figure 5-2).
3. Enter the INET menu shown in Figure 6-4, turning DHCP mode to OFF and editing the Instrument and Gateway IP addresses and Subnet Mask to the desired settings (default settings shown in Table 6-3).

Alternatively, from the computer, enter the same information through an application such as HyperTerminal.

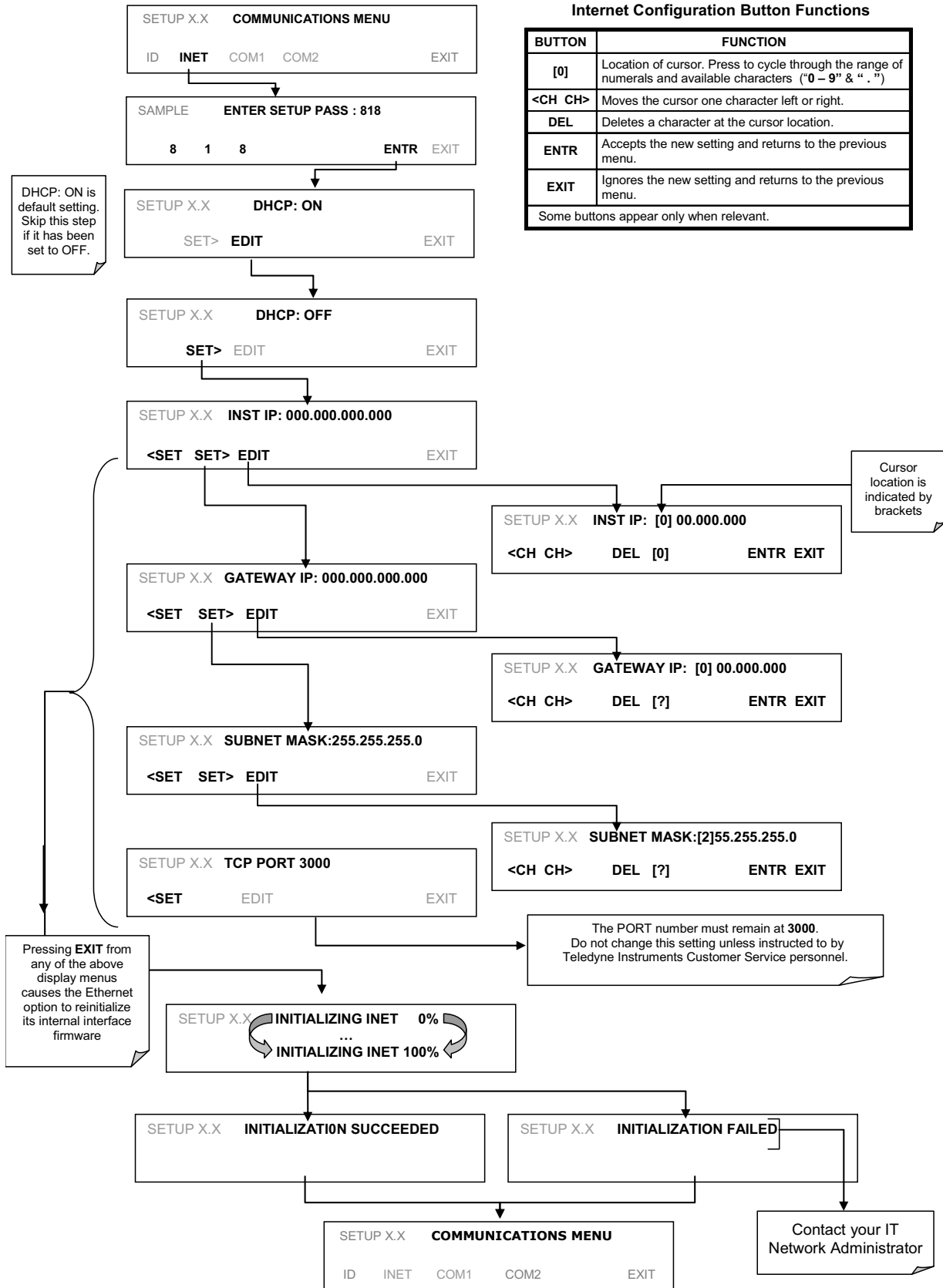

Figure 6-4. COMM - LAN /Internet Manual Configuration

Table 6-3. LAN/Ethernet Default Configuration Properties

PROPERTY	DEFAULT STATE	DESCRIPTION
DHCP	ON	This displays whether the DHCP is turned ON or OFF. Press EDIT and toggle ON for automatic configuration after first consulting network administrator.
INSTRUMENT IP ADDRESS		This string of four packets of 1 to 3 numbers each (e.g. 192.168.76.55.) is the address of the analyzer itself.
GATEWAY IP ADDRESS	0.0.0.0	Can only be edited when DHCP is set to OFF. A string of numbers very similar to the Instrument IP address (e.g. 192.168.76.1.) that is the address of the computer used by your LAN to access the Internet.
SUBNET MASK	0.0.0.0	Can only be edited when DHCP is set to OFF. Also a string of four packets of 1 to 3 numbers each (e.g. 255.255.252.0) that identifies the LAN to which the device is connected. All addressable devices and computers on a LAN must have the same subnet mask. Any transmissions sent to devices with different subnets are assumed to be outside of the LAN and are routed through the gateway computer onto the Internet.
TCP PORT ¹	3000	This number defines the terminal control port by which the instrument is addressed by terminal emulation software, such as Internet or Teledyne API's APICOM.
HOST NAME	[initially blank]	The name by which your analyzer will appear when addressed from other computers on the LAN or via the Internet. To assign or change, see Section 6.5.2.1.

¹ Do not change the setting for this property unless instructed to by TAI's Customer Service personnel.

6.5.2. CONFIGURING ETHERNET COMMUNICATION USING DYNAMIC HOST CONFIGURATION PROTOCOL (DHCP)

The default Ethernet setting is DHCP.

1. Consult with your network administrator to affirm that your network server is running DHCP.

Access the Communications Menu (SETUP>MORE>COMM, see

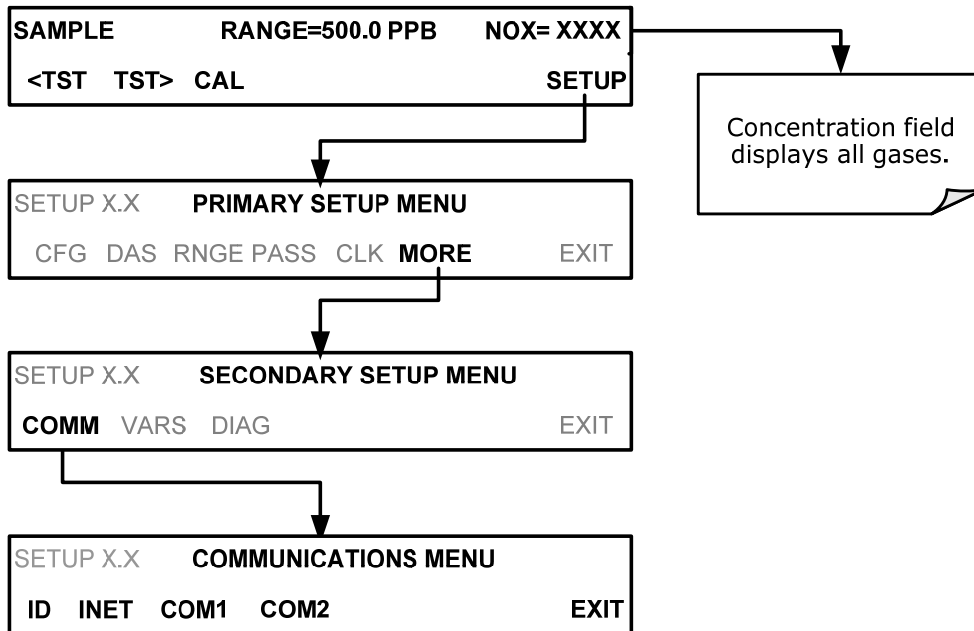

2. Figure 5-2).
3. Enter the INET menu and follow the setup sequence as shown in Figure 6-5.

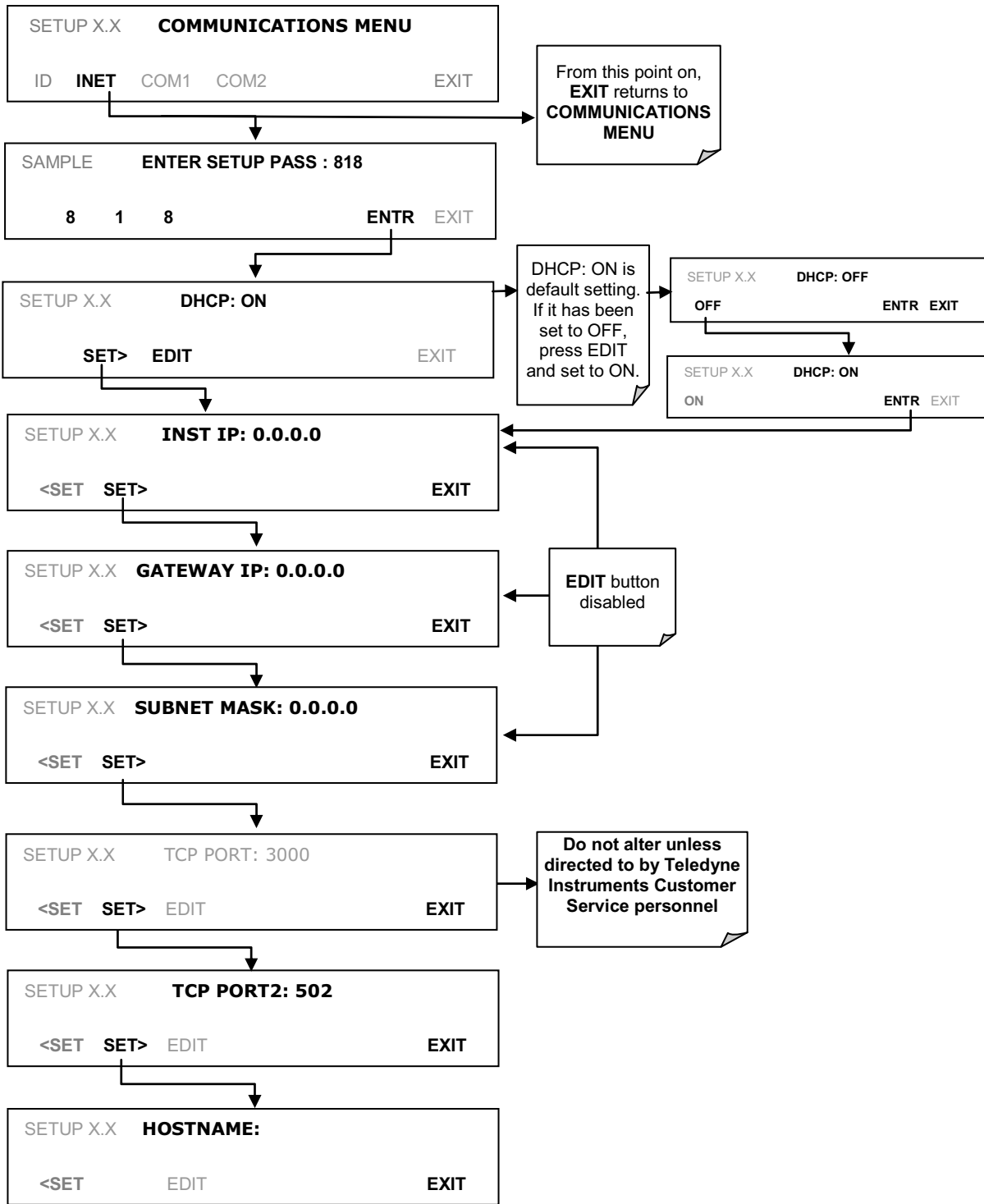

Figure 6-5. COMM – LAN / Internet Automatic Configuration (DHCP)

Note

If the gateway IP, instrument IP and the subnet mask are all zeroes (i.e., "0.0.0.0"), the DHCP was not successful in which case you may have to configure the analyzer's Ethernet properties manually. See your network administrator.

6.5.2.1. Changing the Analyzer's HOSTNAME

The **HOSTNAME** is the name by which the analyzer appears on your network. The initial default Hostname is blank. To assign or change this name (particularly if you have more than one 9110T analyzer on your network, where each must have a different Hostname), enter the **SETUP>COMM>INET** men and scroll to the **HOSTNAME** menu as in Figure 6-5; make the changes as shown in Figure 6-6:

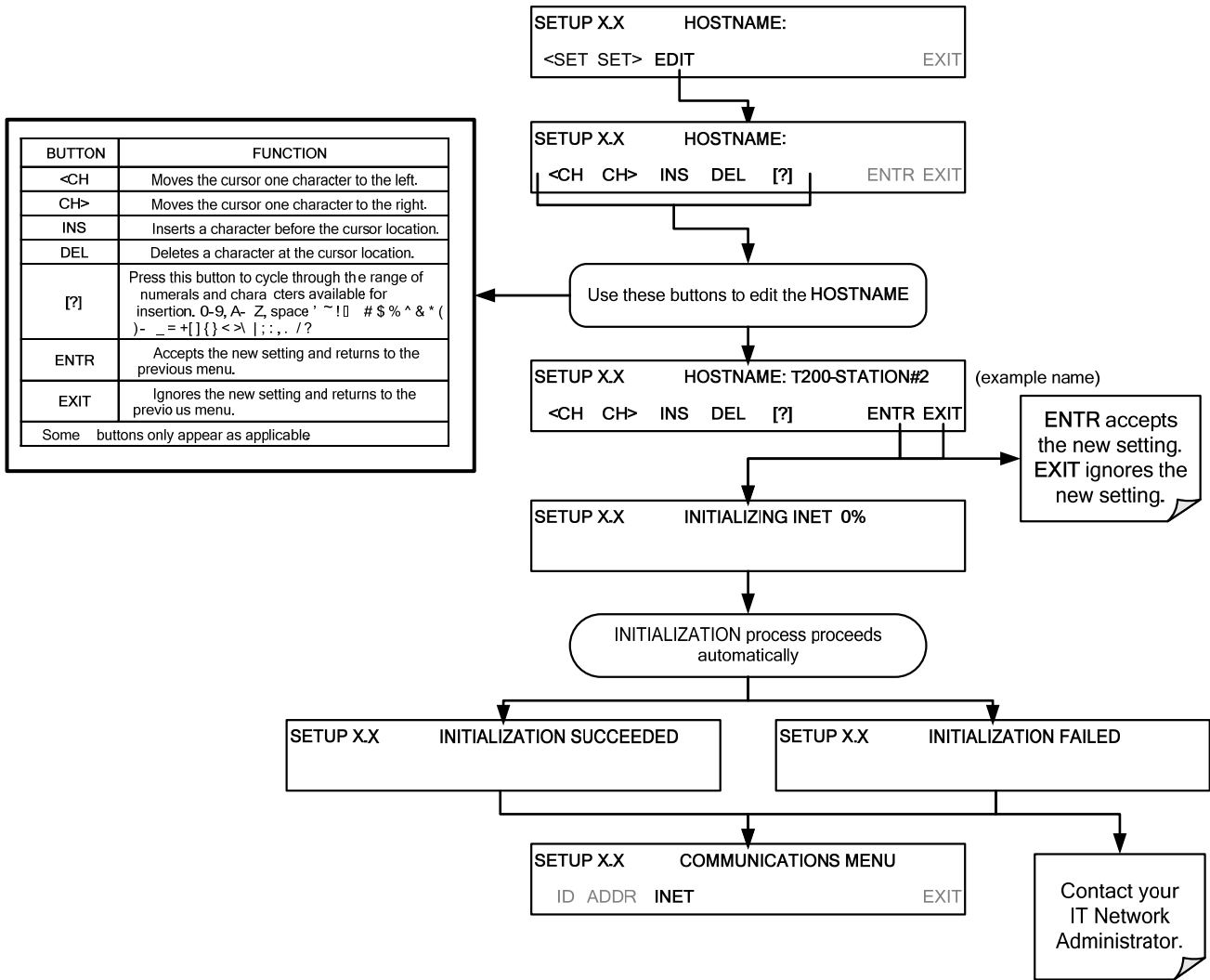
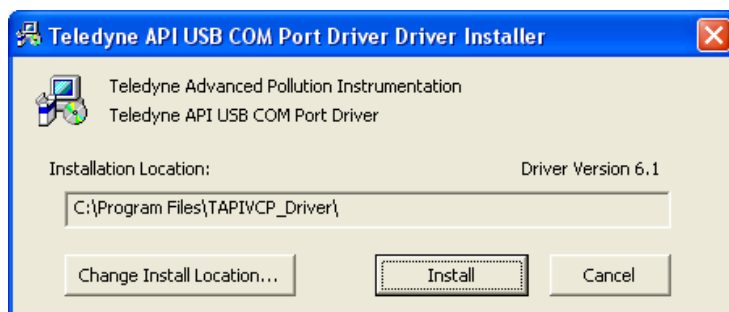

Figure 6-6. COMM – Change Hostname

6.6. USB PORT FOR REMOTE ACCESS

The analyzer can be operated through a personal computer by downloading the TAPI USB driver and directly connecting their respective USB ports.

1. Install the Teledyne T-Series USB driver on your computer, downloadable from the Teledyne API website under Help Center>Software Downloads (www.teledyne-api.com/software).
2. Run the installer file: "TAPIVCPInstaller.exe"
3. Connect the USB cable between the USB ports on your personal computer and your analyzer. The USB cable should be a Type A – Type B cable, commonly used as a USB printer cable.



4. Determine the Windows XP Com Port number that was automatically assigned to the USB connection. (Start → Control Panel → System → Hardware → Device Manager). This is the com port that should be set in the communications software, such as APIcom or Hyperterminal.

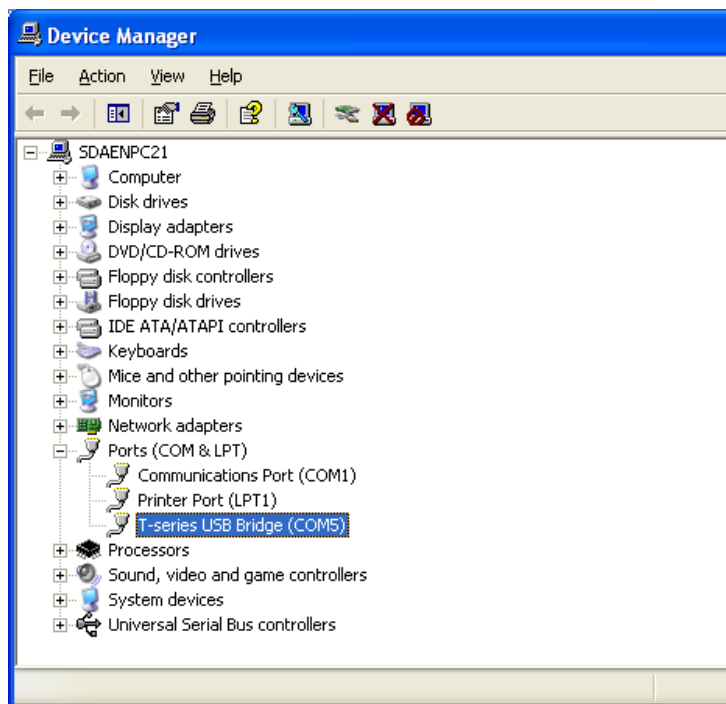

Refer to the Quick Start (*Direct Cable Connection*) section of the Teledyne APIcom Manual, PN 07463.

5. In the instrument's SETUP>MORE>COMM>COM2 menu, make the following settings:

Baud Rate: 115200
 COM2 Mode Settings:
 Quiet Mode ON
 Computer Mode ON
 E,8,1 MODE OFF
 E,7,1 MODE OFF
 RS-485 MODE OFF
 SECURITY MODE OFF
 MULTIDROP MODE OFF
 ENABLE MODEM OFF
 ERROR CHECKING ON
 XON/XOFF HANDSHAKE OFF
 HARDWARE HANDSHAKE OFF
 HARDWARE FIFO ON
 COMMAND PROMPT OFF

- Next, configure your communications software, such as APIcom. Use the COM port determined in Step 4 and the baud rate set in Step 5. The figures below show how these parameters would be configured in the Instrument Properties window in APIcom when configuring a new instrument. See

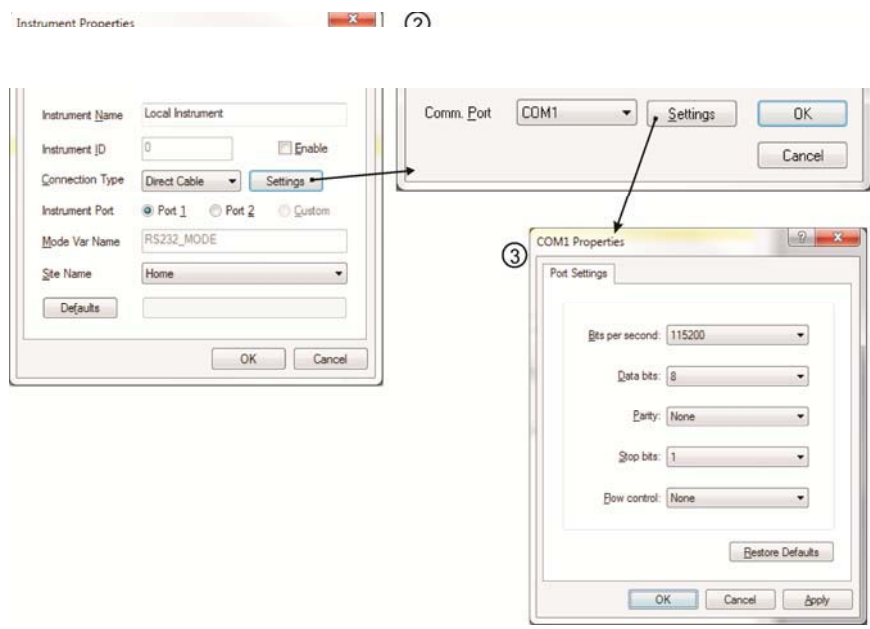

the APIcom manual (PN 07463) for more details.

Note

- **USB configuration requires that the baud rates of the instrument and the PC match; check the PC baud rate and change if needed.**
- **Using the USB port disallows use of the rear panel COM2 port except for multidrop communication.**

This page intentionally left blank.

7. DATA ACQUISITION SYSTEM (DAS) AND APICOM

The 9110T analyzer contains a flexible and powerful, internal data acquisition system (DAS) that enables the analyzer to store concentration and calibration data as well as a host of diagnostic parameters. The DAS feature of the 9110T can store up to one million data points, which can, depending on individual configurations, cover days, weeks or months of valuable measurements. The data records are stored in non-volatile memory and are retained even when the instrument is powered off. Data are stored in plain text format for easy retrieval and use in common data analysis programs (such as electronic spreadsheets).

The DAS is designed to be flexible, users have full control over the type, length and reporting time of the data. The DAS permits users to access stored data through the instrument's front panel or remotely through its communication ports.

The principal use of the DAS is logging data for trend analysis and predictive diagnostics, which can assist in identifying possible problems before they affect the functionality of the analyzer. The secondary use is for data analysis, documentation and archival in electronic format.

To support the DAS functionality, Teledyne offers APICOM, a program that provides a visual interface for remote or local setup, configuration and data retrieval of the DAS. Using APICOM, data can even be retrieved automatically to a remote computer for further processing. The APICOM manual, included with the program, contains a more detailed description of the DAS structure and configuration and is briefly described in this document.

The 9110T is configured with a basic DAS configuration already enabled. The data channels included in this basic structure may be used as is or temporarily disabled for later or occasional use.

The green **SAMPLE LED** on the instrument front panel, which indicates the analyzer status, also indicates certain aspects of the DAS status:

Table 7-1: Front Panel LED Status Indicators for DAS

LED STATE	DAS Status
OFF	System is in calibration mode. Data logging can be enabled or disabled for this mode. Calibration data are typically stored at the end of calibration periods, concentration data are typically not sampled, diagnostic data should be collected.
BLINKING	Instrument is in hold-off mode, a short period after the system exits calibrations. DAS channels can be enabled or disabled for this period. Concentration data are typically disabled whereas diagnostic should be collected.
ON	Sampling normally.

IMPORTANT

IMPACT ON READINGS OR DATA

DAS operation is suspended whenever its configuration is edited using the analyzer's front panel and therefore data may be lost. To prevent such data loss, it is recommended to use the APICOM graphical user interface for DAS changes (Section 7.2.1).

Please be aware that all stored data will be erased if the analyzer's disk-on-module or CPU board is replaced or if the configuration data stored there is reset.

Note

The DAS can be disabled only by disabling or deleting its individual data channels.

7.1. DAS STRUCTURE

The DAS is designed around the feature of a “record”. A record is a single data point. The type of data captured in a record are defined by two properties:

- **PARAMETER** type that defines the kind of data to be stored (e.g. the average of O₃ concentrations measured with three digits of precision). See Section 7.1.3.3.
- A **TRIGGER** event that defines when the record is made (e.g. timer; every time a calibration is performed, etc.). See Section 7.1.3.2.

The specific **PARAMETERS** and **TRIGGER** events that describe an individual record are defined in a construct called a **DATA CHANNEL** (see Section 7.1.3). Each data channel relates one or more parameters with a specific trigger event and various other operational characteristics related to the records being made (e.g. the channels name, number or records to be made, time period between records, whether or not the record is exported via the analyzer’s RS-232 port, etc.).

7.1.1. DAS CHANNELS

The key to the flexibility of the DAS is its ability to store a large number of combinations of triggering events and data parameters in the form of data channels. Users may create up to 20 data channels and each channel can contain one or more parameters. For each channel, the following are selected:

- one triggering event
- up to 50 data parameters, which can be the shared between channels.
- several other properties that define the structure of the channel and allow the user to make operational decisions regarding the channel.

Table 7-2: DAS Data Channel Properties

PROPERTY	DESCRIPTION	DEFAULT SETTING	SETTING RANGE
NAME	The name of the data channel.	“NONE”	Up to 6 letters or digits ¹ .
TRIGGERING EVENT	The event that triggers the data channel to measure and store the datum.	ATIMER	Any available event (see Appendix A-5).
NUMBER AND LIST OF PARAMETERS	A user-configurable list of data types to be recorded in any given channel.	1 (PMTDET)	Any available parameter (see Appendix A-5).
REPORT PERIOD	The amount of time between each channel data point.	000:01:00 (1 hour)	000:00:01 to 366:23:59 (Days:Hours:Minutes)
NUMBER OF RECORDS	The number of reports that will be stored in the data file. Once the limit is exceeded, the oldest data is over-written.	100	1 to 1 million, limited by available storage space.
RS-232 REPORT	Enables the analyzer to automatically report channel values to the RS-232 ports.	OFF	OFF or ON

PROPERTY	DESCRIPTION	DEFAULT SETTING	SETTING RANGE
CHANNEL ENABLED	Enables or disables the channel. Allows a channel to be temporarily turned off without deleting it.	ON	OFF or ON
CAL HOLD OFF	Disables sampling of data parameters while instrument is in calibration mode ² .	OFF	OFF or ON
¹ More with APICOM, but only the first six are displayed on the front panel). ² When enabled records are not recorded until the DAS_HOLD OFF period is passed after calibration mode. DAS_HOLD OFF SET in the VARS menu (see Section 5.8).			

7.1.1.1. Default DAS Channels

A set of default Data Channels has been included in the analyzer's software for logging NO_x, NO and NO₂ concentrations as well as certain predictive diagnostic data. For the software revision being shipped with the 9110T at the time of this writing, these default channels are:

CONC: Samples NO_x concentration at one minute intervals and stores an average every hour with a time and date stamp. Readings during calibration and calibration hold off are not included in the data.

- By default, the last 800 hourly averages are stored.

CALDAT: Logs new slope and offset of NO_x and NO measurements every time a zero or span calibration is performed and the result changes the value of the slope (triggering event: **SLPCHG**). The NO_x stability (to evaluate if the calibration value was stable) as well as the converter efficiency (for trend reference) are also stored.

- This data channel will store data from the last 200 calibrations and can be used to document analyzer calibration and is useful for detect trends in slope and offset (instrument response) when performing predictive diagnostics as part of a regular maintenance schedule (See Section 11.1).
- The CALDAT channel collects data based on events (e.g. a calibration operation) rather than a timed interval and therefore does not represent any specific length of time. As with all data channels, a date and time stamp is recorded for every logged data point.

CALCHECK: This channel logs concentrations and the stability each time a zero or span check (not calibration) is finished (triggered by exiting any calibration menu).

- The data of this channel enable the user to track the quality of zero and span responses over time and assist in evaluating the quality of zero and span gases and the analyzer's noise specifications.
- The **STABIL** parameter documents if the analyzer response was stable at the point of the calibration check reading. The last 200 data points are retained.

DIAG: Daily averages of temperature zones, flow and pressure data as well as some other diagnostic parameters (**HVPS**, **AZERO**).

- This data is useful for predictive diagnostics and maintenance of the 9110T.
- The last 1100 daily averages are stored to cover more than four years of analyzer performance.

HIRES: Records one-minute, instantaneous data of all active parameters in the 9110T. Short-term trends as well as signal noise levels can be detected and documented.

- Readings during calibration and the calibration hold off period are included in the averages.
- The last 1500 data points are stored, which covers a little more than one day of continuous data acquisition.

These default data channels can be used as they are, or they can be customized from the front panel to fit a specific application. They can also be deleted to make room for custom user-programmed Data Channels.

Appendix A lists the firmware-specific DAS configuration in plain-text format. This text file can either be loaded into APICOM and then modified and uploaded to the instrument or can be copied and pasted into a terminal program to be sent to the analyzer.

IMPORTANT

IMPACT ON READINGS OR DATA

Sending a DAS configuration to the analyzer through its COM ports will replace the existing configuration and will delete all stored data. Back up any existing data and the DAS configuration before uploading new settings.

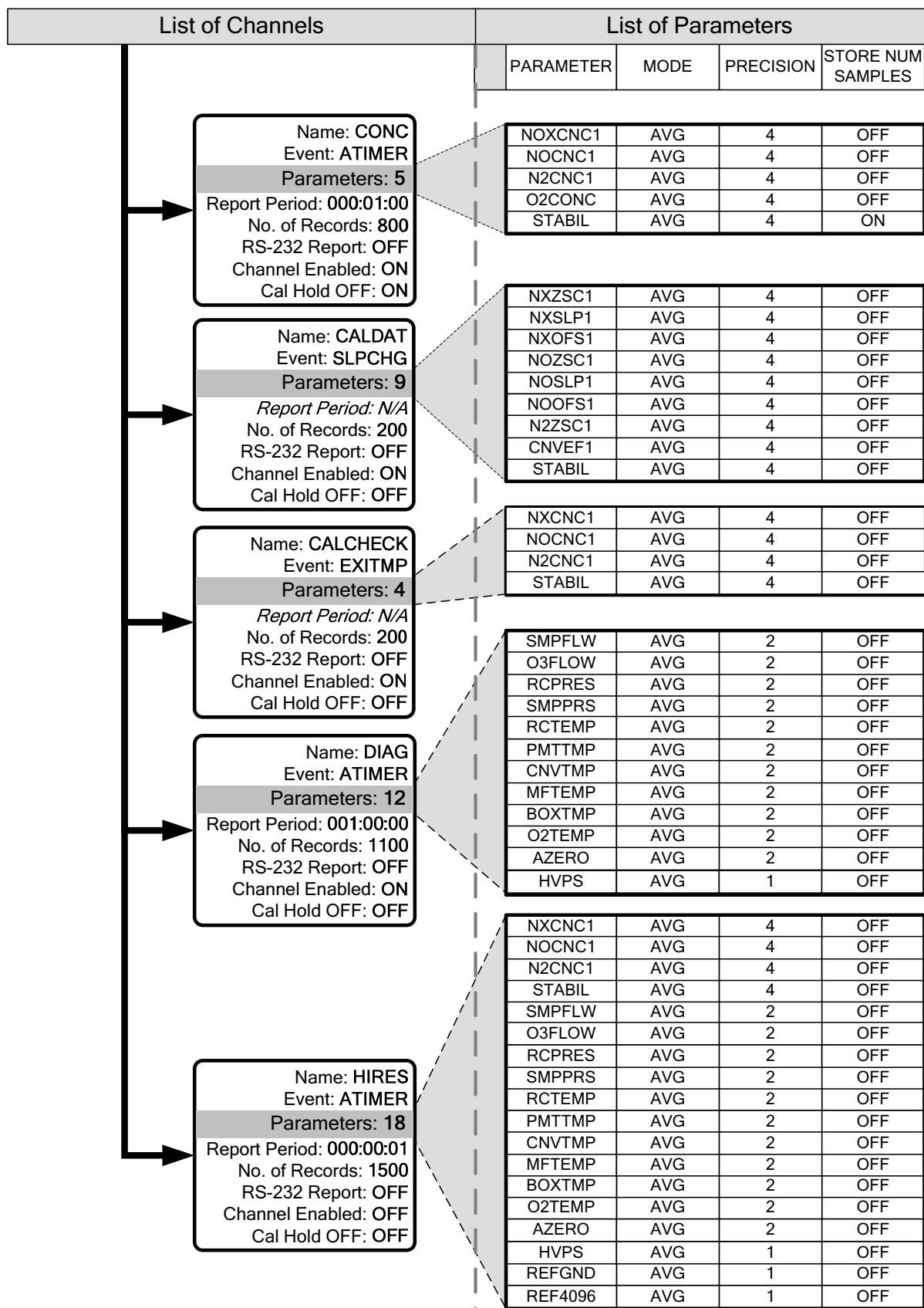

Figure 7-1: Default DAS Channels Setup

7.1.1.2. DAS Configuration Limits

The number of DAS objects are limited by the instrument’s finite storage capacity. For information regarding the maximum number of channels, parameters, and records and how to calculate the file size for each data channel, refer to the DAS manual downloadable from the Teledyne website at <http://www.teledyne-api.com/manuals/> under Special Manuals.

7.1.2. VIEWING DAS DATA AND SETTINGS

DAS data and settings can be viewed on the front panel through the following menu sequence.

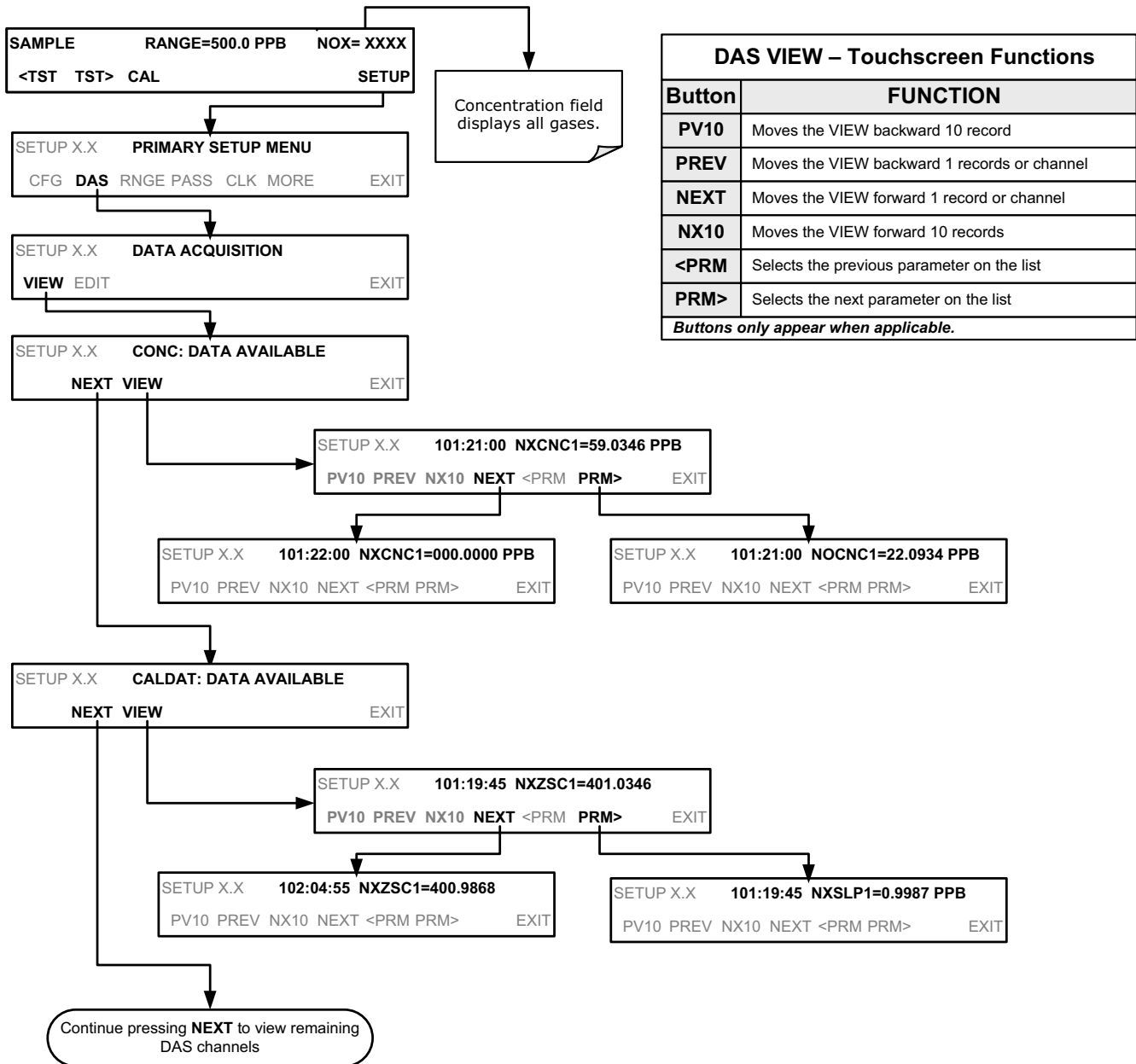

7.1.3. EDITING DAS DATA CHANNELS

DAS configuration is most conveniently done through the APICOM remote control program. The following list of button strokes shows how to edit using the front panel.

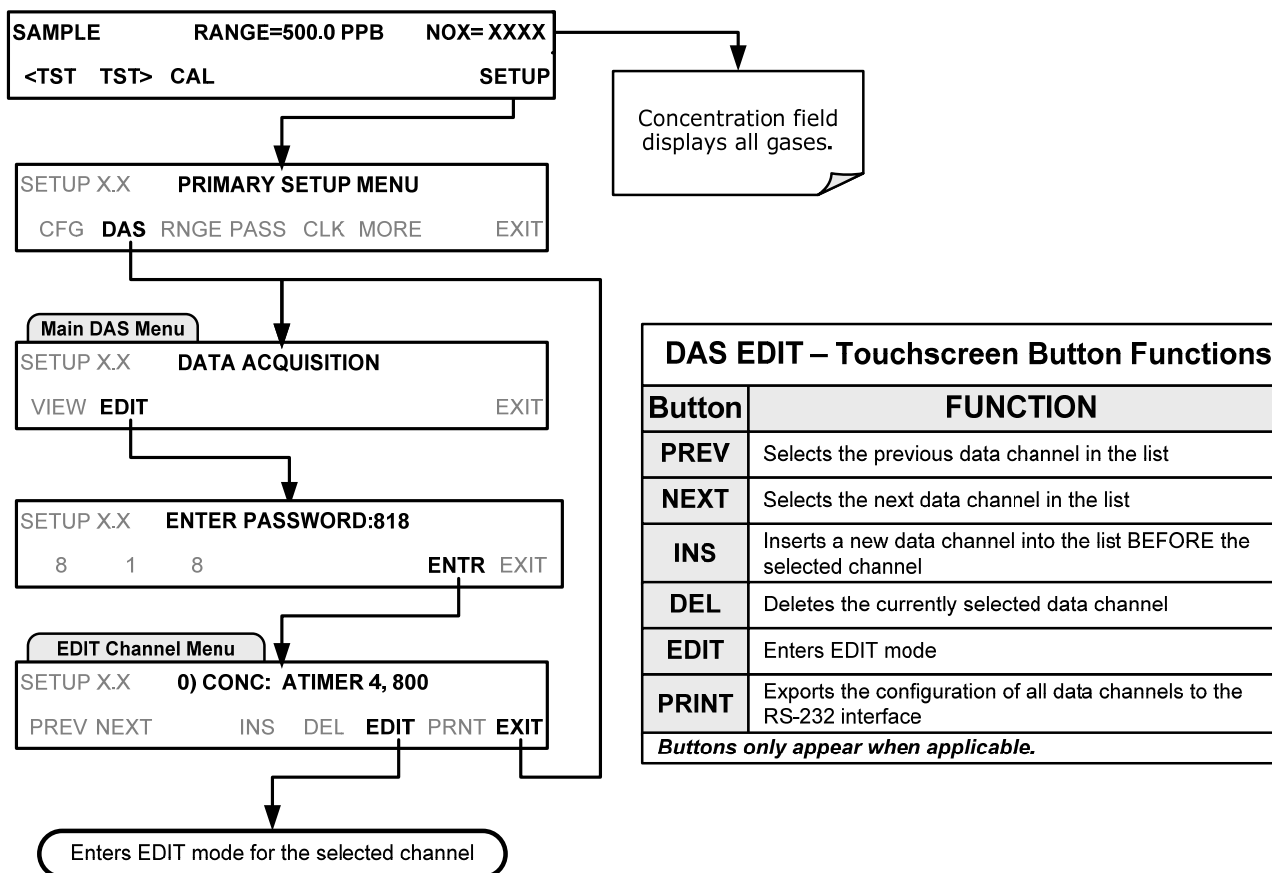

When editing the data channels, the top line of the display indicates some of the configuration parameters.

For example, the display line:

0) NXCNC1: ATIMER, 5, 800

Translates to the following configuration:

Channel No.: 0
NAME: NXCNC1
TRIGGER EVENT: ATIMER
PARAMETERS: Five parameters are included in this channel
EVENT: This channel is set up to store 800 records.

7.1.3.1. Editing DAS Data Channel Names

To edit the name of a DAS data channel, follow the instruction shown in Section 7.1.3 then press:

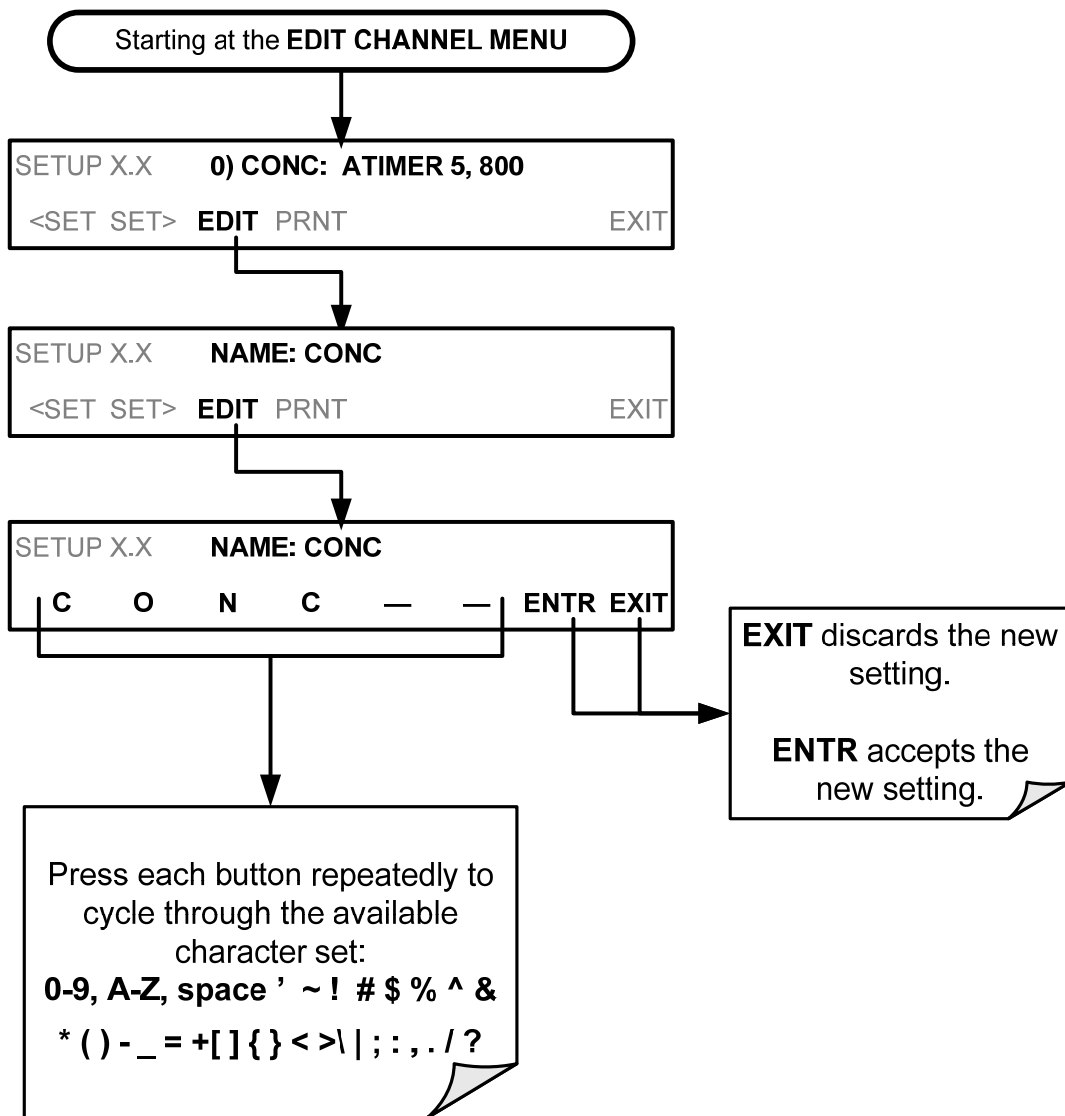

7.1.3.2. Editing DAS Triggering Events

Triggering events define when and how the DAS records a measurement of any given data channel. Triggering events are firmware-specific and a complete list of Triggers for this model analyzer can be found in Appendix A-5. The most commonly used triggering events are:

- **ATIMER:** Sampling at regular intervals specified by an automatic timer. Most trending information is usually stored at such regular intervals, which can be instantaneous or averaged.
- **EXITZR, EXITSP, and SLPCHG** (exit zero, exit span, slope change): Sampling at the end of (irregularly occurring) calibrations or when the response slope changes. These triggering events create instantaneous data points, e.g., for the new slope and offset (concentration response) values at the end of a calibration. Zero and slope values are valuable to monitor response drift and to document when the instrument was calibrated.
- **WARNINGS:** Some data may be useful when stored if one of several warning messages appears such as **WTEMPW** (GFC wheel temperature warning). This is helpful for troubleshooting by monitoring when a particular warning occurred.

To edit the list of data parameters associated with a specific data channel, follow the instruction shown in Section 7.1.3 then press:

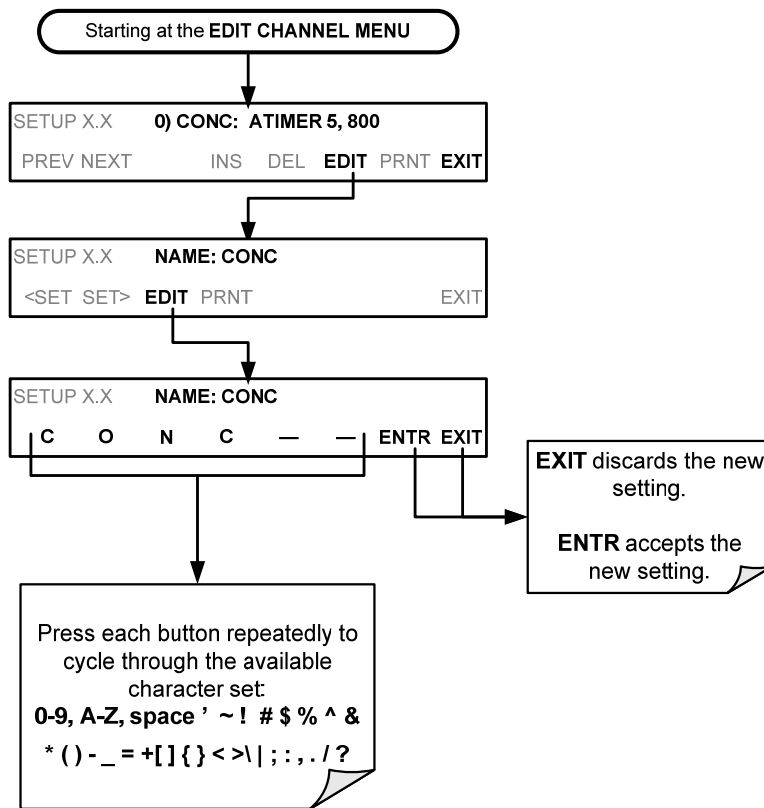

Note

A full list of DAS Trigger Events can be found in Appendix A-5 of this manual.

7.1.3.3. Editing DAS Parameters

Data parameters are types of data that may be measured and stored by the DAS. For each TAI's analyzer model, the list of available data parameters is different, fully defined and not customizable. Appendix A-5 lists firmware specific data parameters for the 9110T. DAS parameters include data such as NO_x, NO and NO₂ concentration measurements, temperatures of the various heaters placed around the analyzer, pressures and flows of the pneumatic subsystem and other diagnostic measurements as well as calibration data such as stability, slope and offset.

Most data parameters have associated measurement units, such as mV, ppb, cm³/min, etc., although some parameters have no units (e.g. **SLOPE**). With the exception of concentration readings, none of these units of measure can be changed. To change the units of measure for concentration readings, see Section 5.4.3.4.

Note

DAS does not keep track of the units (i.e. PPM or PPB) of each concentration value. Therefore, DAS data files may contain concentration data recorded in more than one type of unit if the units of measure were changed during data acquisition

Each data parameter has user-configurable functions that define how the data are recorded which are listed in Table 7-3:

Table 7-3: DAS Data Parameter Functions

FUNCTION	EFFECT
PARAMETER	Instrument specific parameter name.
SAMPLE MODE	INST: Records instantaneous reading. AVG: Records average reading during reporting interval. SDEV: Records the standard deviation of the data points recorded during the reporting interval. MIN: Records minimum (instantaneous) reading during reporting interval. MAX: Records maximum (instantaneous) reading during reporting interval.
PRECISION	0 to 4: Sets the number of digits to the right decimal point for each record. Example: Setting 4 ; "399.9865 PPB" Setting 0 ; "400 PPB"
STORE NUM. SAMPLES	OFF: Stores only the average (default). ON: Stores the average and the number of samples in used to compute the value of the parameter. This property is only useful when the AVG sample mode is used. Note that the number of samples is the same for all parameters in one channel and needs to be specified only for one of the parameters in that channel.

Users can specify up to 50 parameters per data channel (the 9110T provides about 40 parameters). However, the number of parameters and channels is ultimately limited by available memory.

Data channels can be edited individually from the front panel without affecting other data channels. However, when editing a data channel, such as during adding, deleting or editing parameters, all data for that particular channel will be lost, because the DAS can store only data of one format (number of parameter columns etc.) for any given channel. In addition, a DAS configuration can only be uploaded remotely as an entire set of channels. Hence, remote update of the DAS will always delete all current channels and stored data.

To modify, add or delete a parameter, follow the instruction shown in Section 7.1.3 then press:

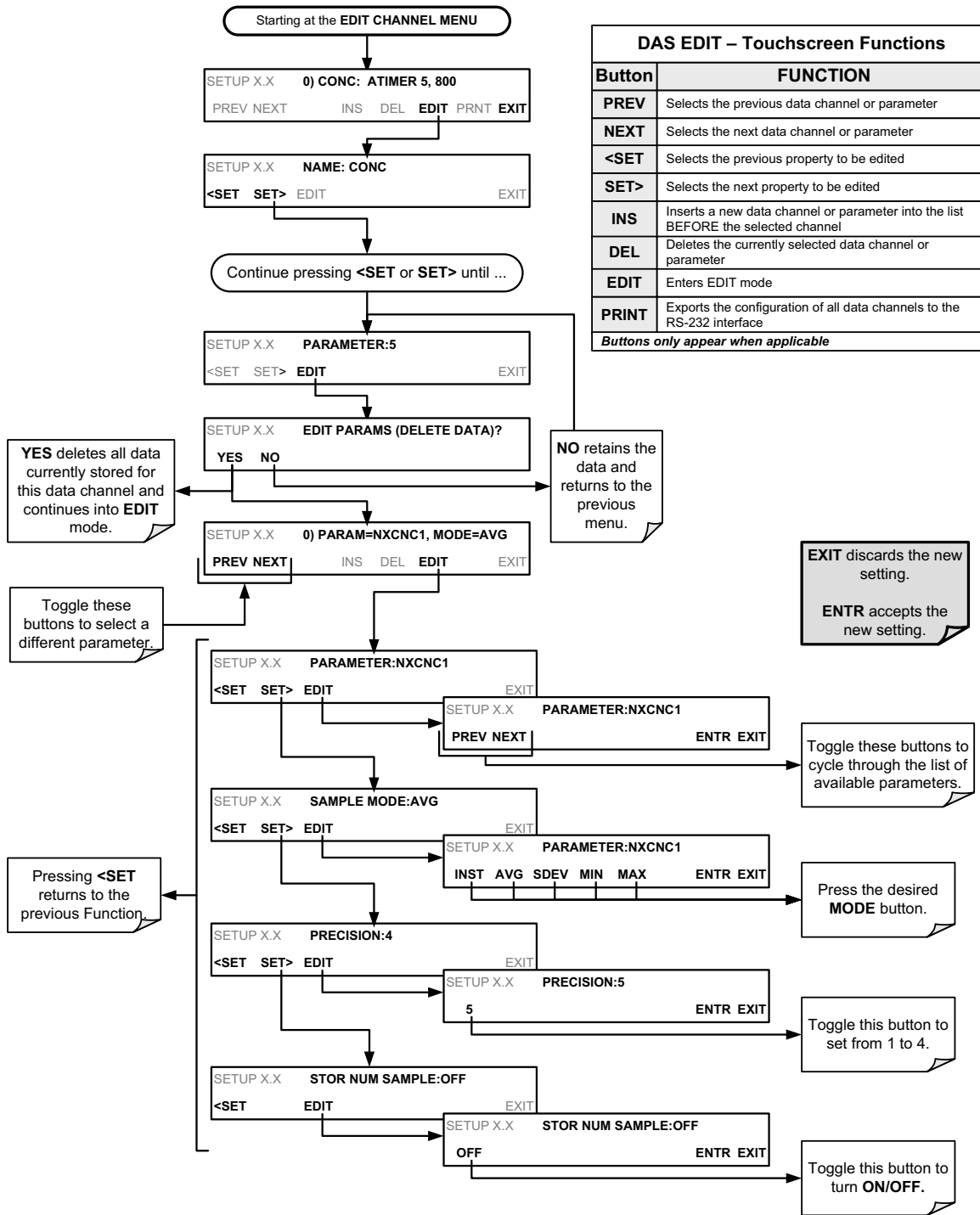

Note

When the STORE NUM SAMPLES feature is turned on, the instrument will store the number of measurements that were used to compute the AVG, SDEV, MIN or MAX value but not the actual measurements themselves.

7.1.3.4. Editing Sample Period and Report Period

The DAS defines two principal time periods by which sample readings are taken and permanently recorded:

- **SAMPLE PERIOD:** Determines how often DAS temporarily records a sample reading of the parameter in volatile memory. **SAMPLE PERIOD** is only used when the DAS parameter's sample mode is set for AVG, SDEV, MIN or MAX.
- The **SAMPLE PERIOD** is set to one minute by default and generally cannot be accessed from the standard DAS front panel menu, but is available via the instruments communication ports by using APICOM or the analyzer's standard serial data protocol.
- **REPORT PERIOD:** Sets how often the sample readings stored in volatile memory are processed, (e.g. average, minimum or maximum are calculated) and the results stored permanently in the instruments Disk-on-Module (DOM) as well as transmitted via the analyzer's communication ports. The Report Period may be set from the front panel. If the INST sample mode is selected the instrument stores and reports an instantaneous reading of the selected parameter at the end of the chosen report period.

Note

In AVG, SDEV, MIN or MAX sample modes (see Section 7.1.3.3), the settings for the Sample Period and the Report Period determine the number of data points used each time the parameters are calculated, stored and reported to the COMM ports.

The actual sample readings are not stored past the end of the chosen report period.

When the STORE NUM SAMPLES feature is turned on, the instrument will store the number of measurements that were used to compute the AVG, SDEV, MIN or MAX value but not the actual measurements themselves.

To define the **REPORT PERIOD**, follow the instruction shown in Section 7.1.3 then press:

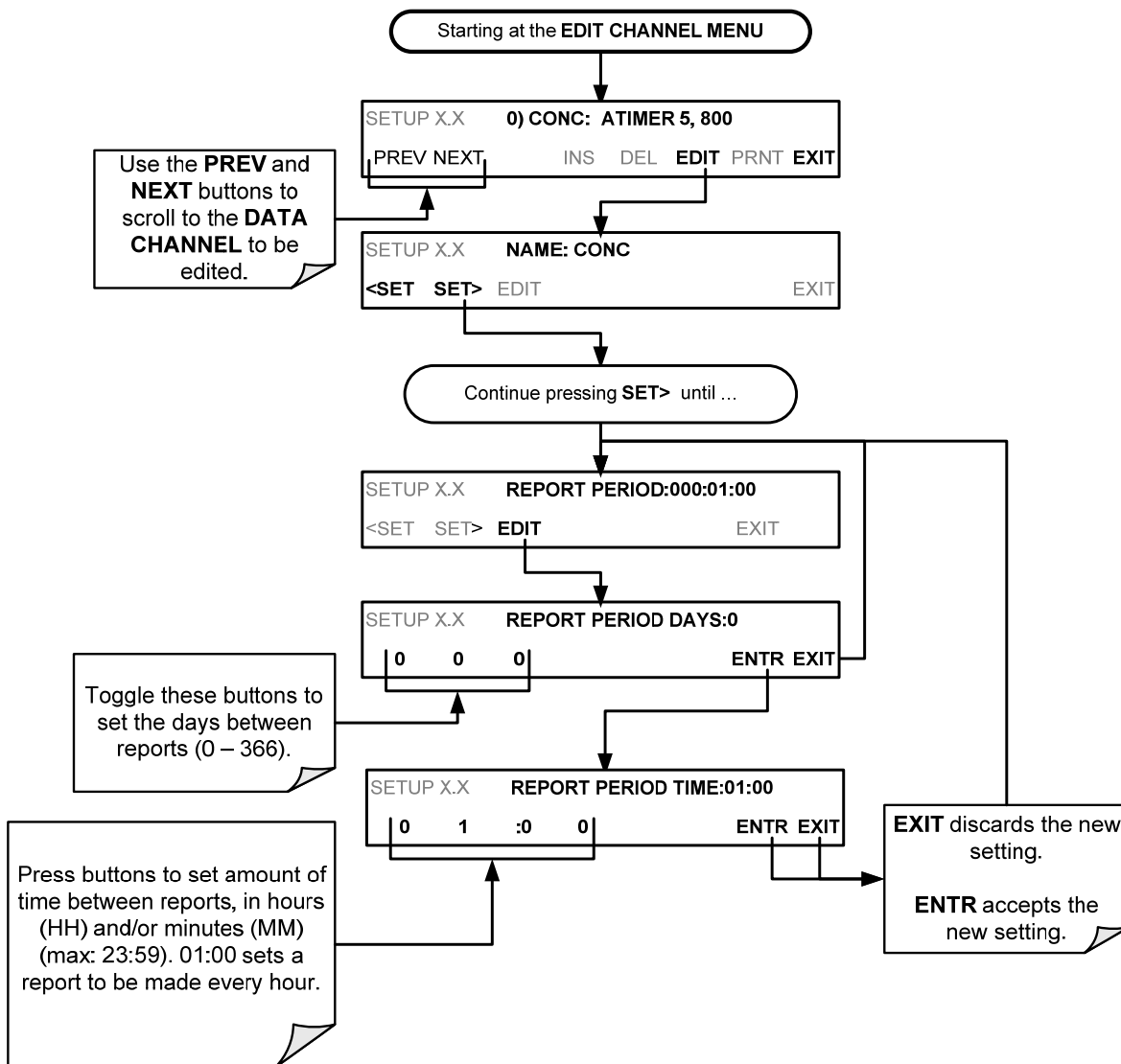

The **SAMPLE PERIOD** and **REPORT PERIOD** intervals are synchronized to the beginning and end of the appropriate interval of the instruments internal clock.

- If **SAMPLE PERIOD** is set for one minute the first reading would occur at the beginning of the next full minute according to the instrument’s internal clock.
- If the **REPORT PERIOD** is set for of one hour, the first report activity would occur at the beginning of the next full hour according to the instrument’s internal clock.

EXAMPLE:

Given the above settings, if DAS parameters are activated at 7:57:35 the first sample would occur at 7:58 and the first report would be calculated at 8:00 consisting of data points for 7:58. 7:59 and 8:00.

During the next hour (from 8:01 to 9:00), the instrument will take a sample reading every minute and include 60 sample readings.

7.1.3.5. Report Periods in Progress when Instrument Is Powered Off

If the instrument is powered off in the middle of a **REPORT PERIOD**, the samples accumulated during that period are lost. Once the instrument is turned back on, the DAS restarts taking samples and

temporarily stores them in volatile memory as part of the **REPORT PERIOD** currently active at the time of restart. At the end of this **REPORT PERIOD**, only the sample readings taken since the instrument was turned back on will be included in any **AVG**, **SDEV**, **MIN** or **MAX** calculation.

The **STORE NUM SAMPLES** feature will also report the number of sample readings taken since the instrument was restarted.

7.1.3.6. Editing the Number of Records

The number of data records in the DAS is limited to about a cumulative one million data points in all channels (one megabyte of space on the DOM). However, the actual number of records is also limited by the total number of parameters and channels and other settings in the DAS configuration. Every additional data channel, parameter, number of samples setting etc. will reduce the maximum amount of data points. In general, however, the maximum data capacity is divided amongst all channels (max: 20) and parameters (max: 50 per channel).

The DAS will check the amount of available data space and prevent the user from specifying too many records at any given point. If, for example, the DAS memory space can accommodate 375 more data records, the **ENTR** button will disappear when trying to specify more than that number of records. This check for memory space may also make an upload of a DAS configuration with APICOM or a terminal program fail, if the combined number of records would be exceeded. In this case, it is suggested to either try to determine what the maximum number of records available is using the front panel interface or use trial-and-error in designing the DAS script or calculate the number of records using the DAS or APICOM manuals.

To set the **NUMBER OF RECORDS**, follow the instruction shown in Section 7.1.3 then press:

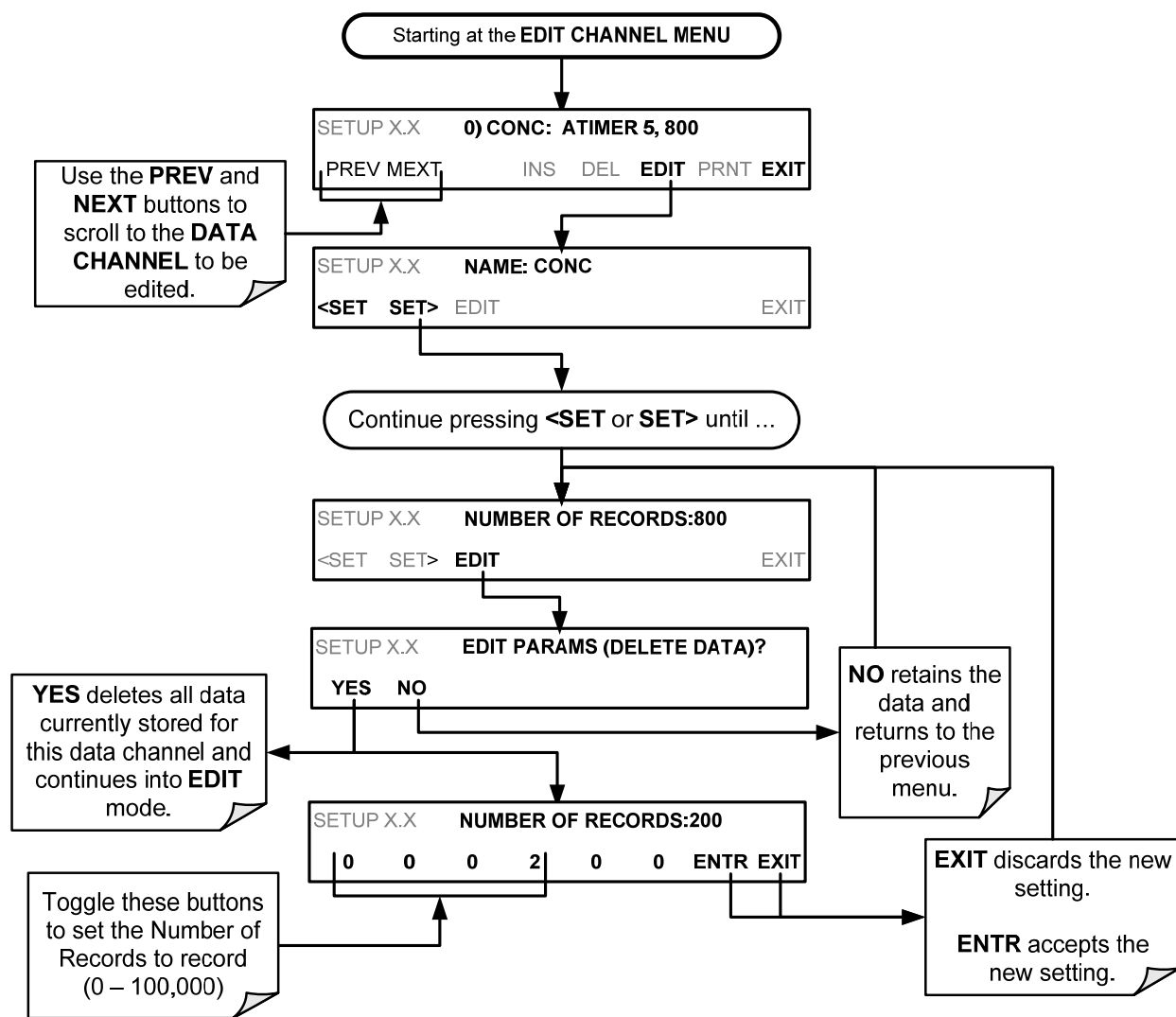

7.1.3.7. RS-232 Report Function

The DAS can automatically report data to the communications ports, where they can be captured with a terminal emulation program or simply viewed by the user using the APICOM software.

To enable automatic **COMM** port reporting, follow the instruction shown in Section 7.1.3 then press:

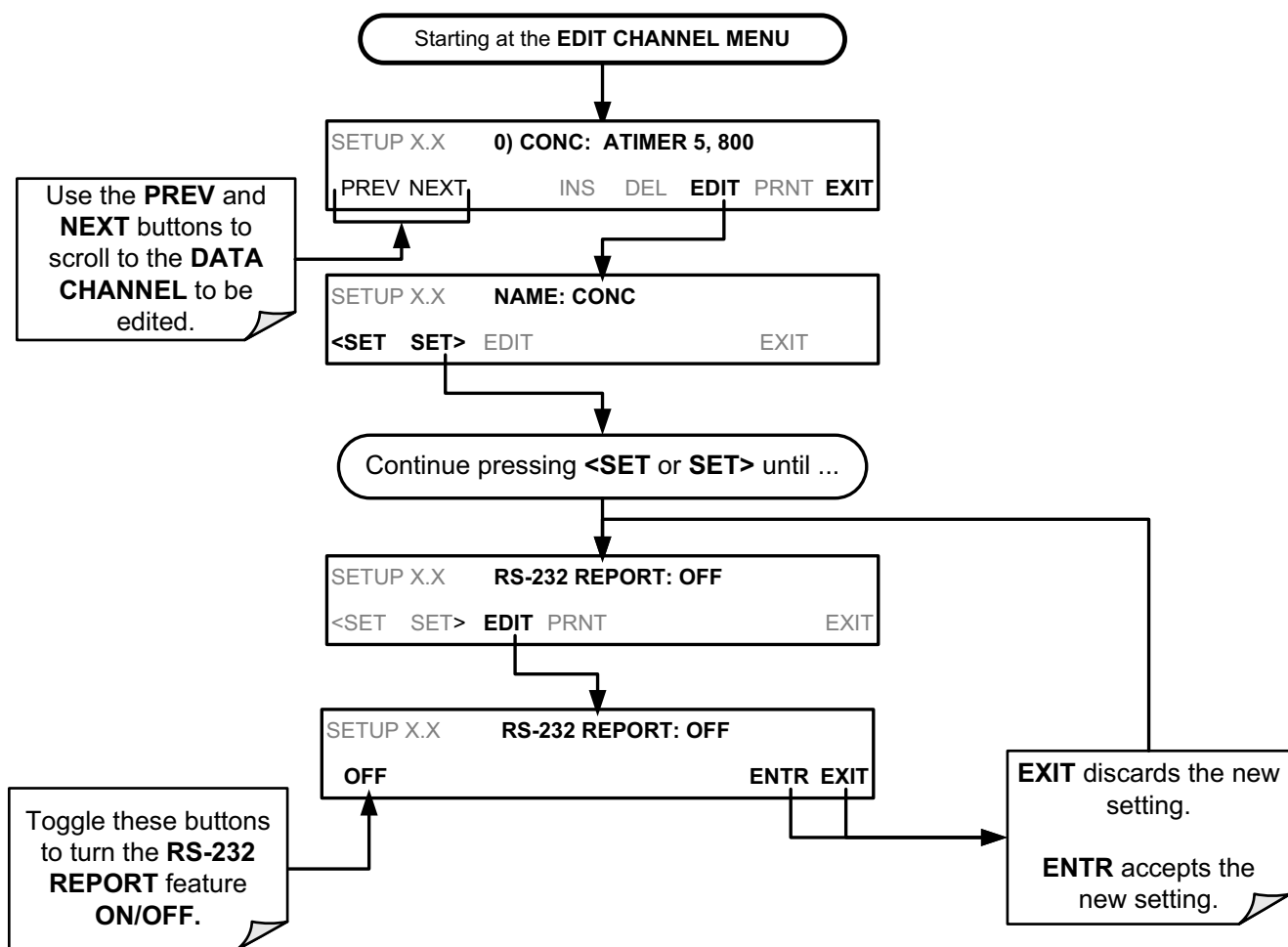

7.1.3.8. HOLDOFF Feature

The DAS **HOLDOFF** feature prevents data collection during calibration operations.

To enable or disable the **HOLDOFF**, follow the instruction shown in Section 7.1.3 then press:

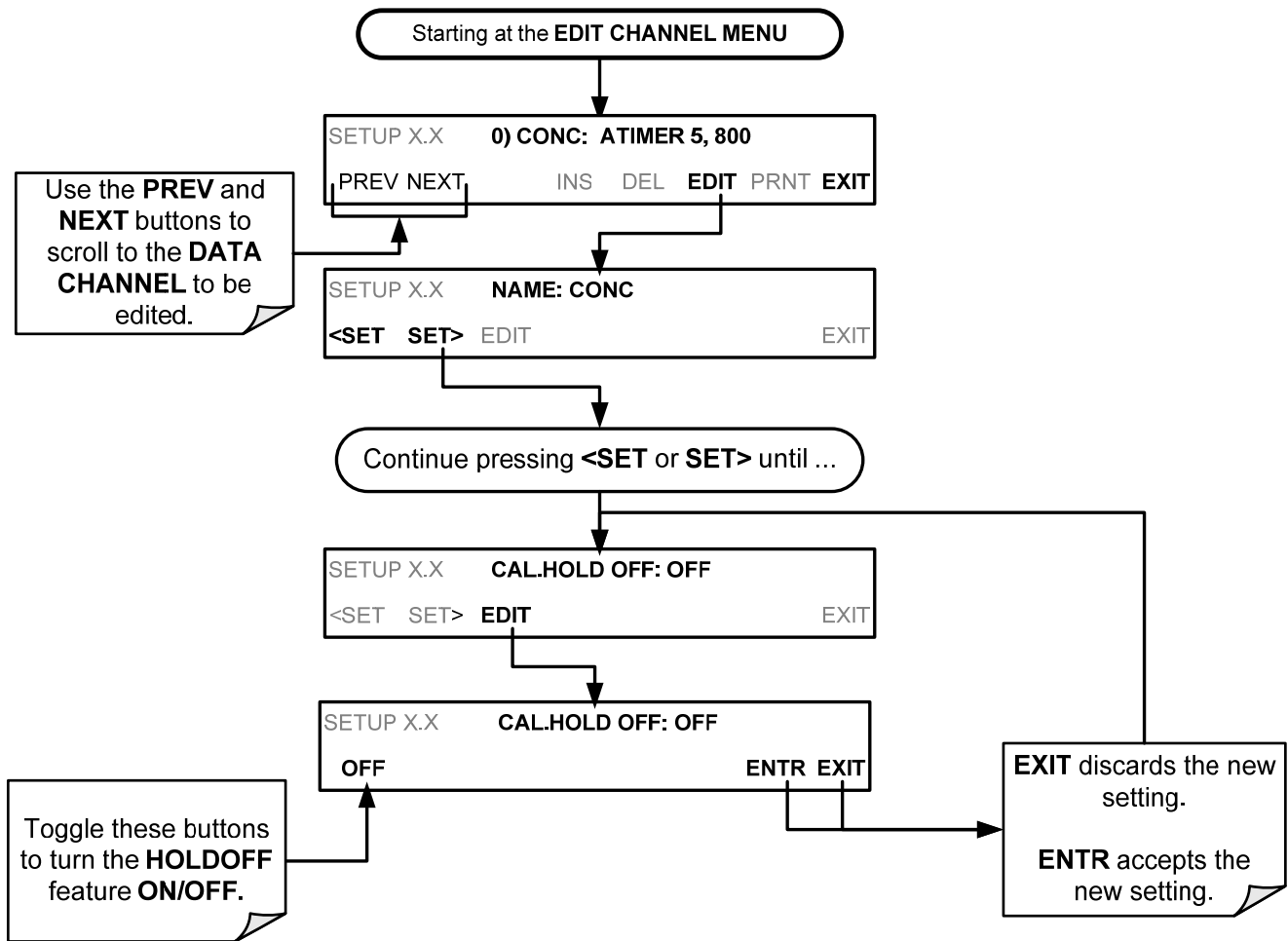

HOLDOFF also prevents DAS measurements from being made at certain times when the quality of the analyzer’s O₃ measurements may be suspect (e.g. while the instrument is warming up). In this case, the length of time that the **HOLDOFF** feature is active is determined by the value of the internal variable (**VAR**s), **DAS_HOLD**OFF.

To set the length of the **DAS_HOLD**OFF period, go to the **SETUP>MORE>VAR**s menu and at the **DAS_HOLD**OFF parameter (see Table 5-3), press the Edit button.

7.1.3.9. The Compact Report Feature

When enabled, this option avoids unnecessary line breaks on all RS-232 reports. Instead of reporting each parameter in one channel on a separate line, up to five parameters are reported in one line.

The **COMPACT DATA REPORT** generally cannot be accessed from the standard DAS front panel menu, but is available via the instrument's communication ports by using APICOM or the analyzer's standard serial data protocol.

7.1.3.10. The Starting Date Feature

This option allows the user to specify a starting date for any given channel when the user wants to start data acquisition only after a certain time and date. If the **STARTING DATE** is in the past (the default condition), the DAS ignores this setting and begins recording data as defined by the **REPORT PERIOD** setting.

The **STARTING DATE** generally cannot be accessed from the standard DAS front panel menu, but is available via the instrument's communication ports by using APICOM or the analyzer's standard serial data protocol.

7.1.3.11. Disabling/Enabling Data Channels

Data channels can be temporarily disabled, which can reduce the read/write wear on the Disk-on-Module (DOM).

To disable a data channel, go to the DAS>EDIT menu as shown in Section 7.1.3 then continue as follows:

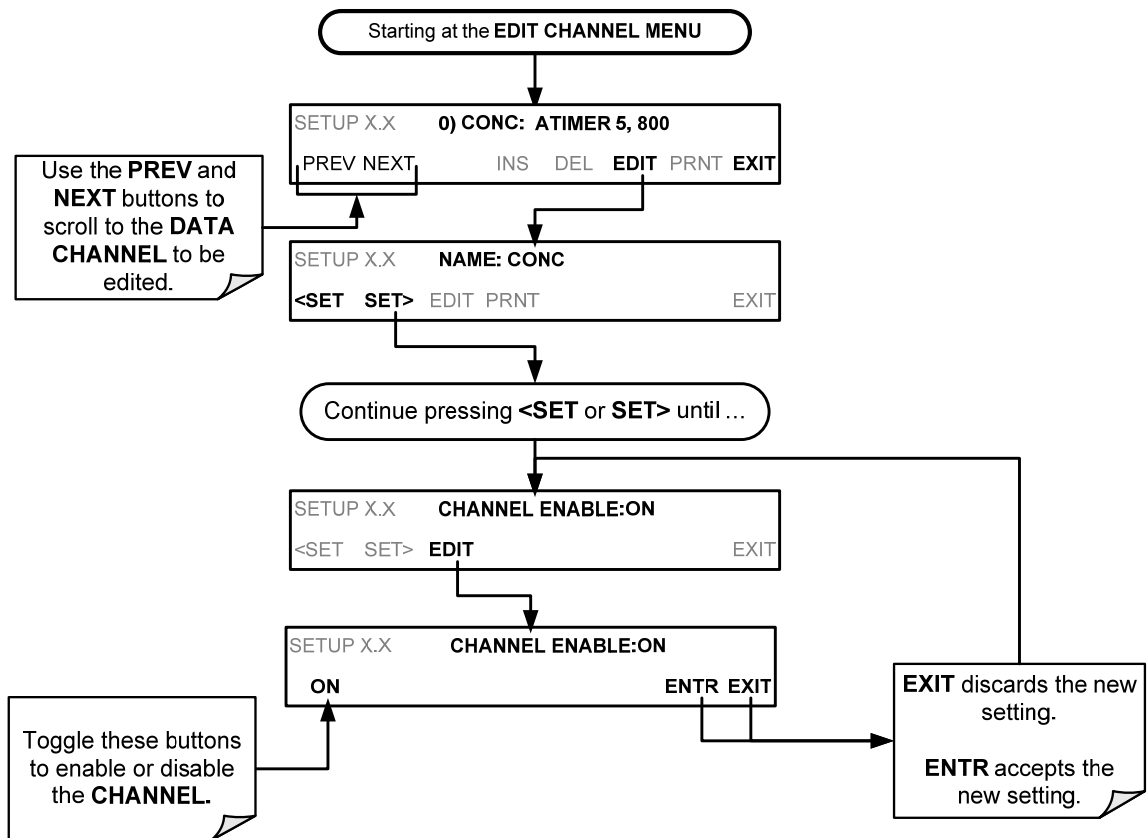

7.2. REMOTE DAS CONFIGURATION

The DAS can be configured and operated remotely via either the APICOM interface or a terminal emulation program. Once a DAS configuration is edited (which can be done offline and without interrupting DAS data collection), it is conveniently uploaded to the instrument and can be stored on a computer for later review, alteration or documentation and archival.

7.2.1. DAS CONFIGURATION VIA APICOM

Table 7-2 shows examples of APICOM's main interface, which emulates the look and functionality of the instrument's actual front panel. Figure 7-3 shows an example of APICOM being used to remotely configure the DAS feature.

The APICOM user manual (Teledyne P/N 039450000) is included in the APICOM installation file, which can be downloaded at <http://www.teledyne-api.com/software/apicom/>.

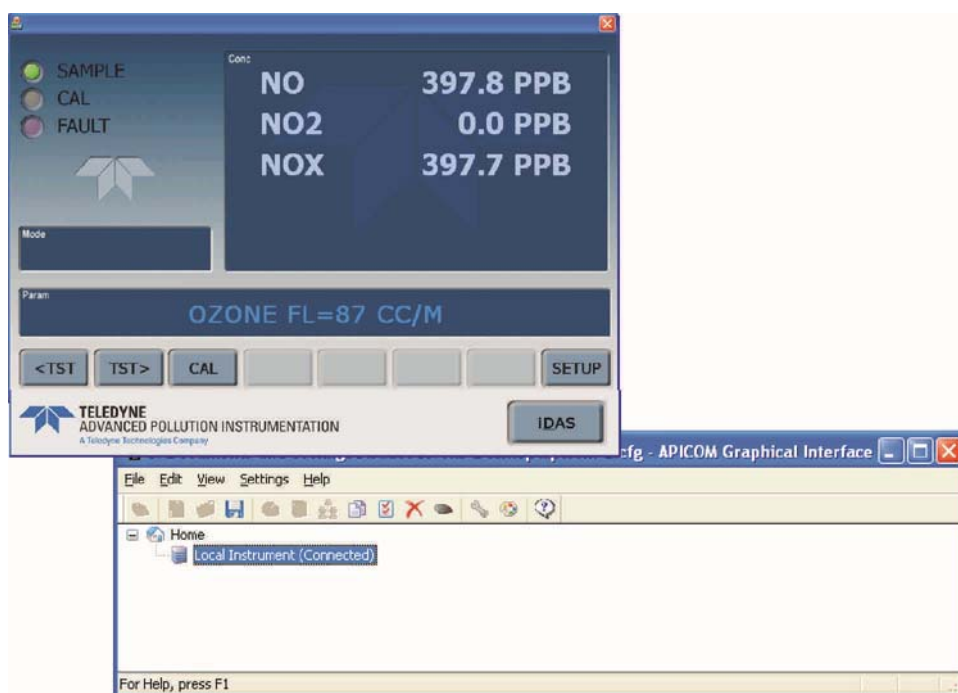

Figure 7-2: APICOM Remote Control Program Interface

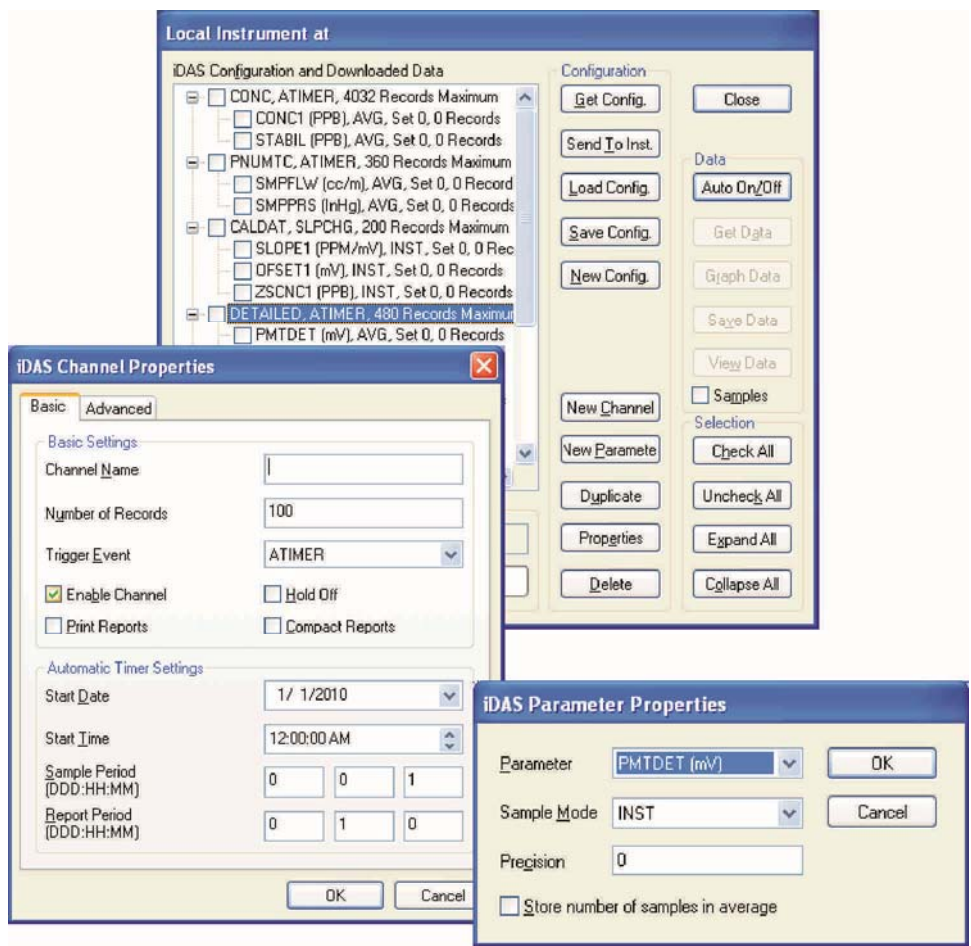
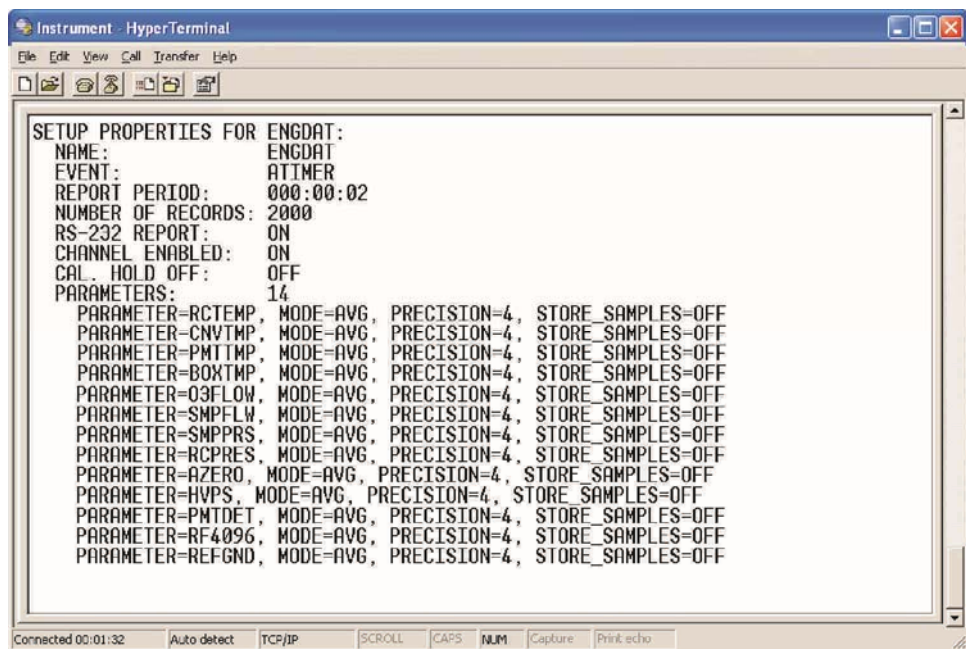

Figure 7-3: Sample APICOM User Interface for Configuring the DAS

7.2.2. DAS CONFIGURATION VIA TERMINAL EMULATION PROGRAMS

Although TAI recommends the use of APICOM, the DAS can also be accessed and configured through a terminal emulation program such as HyperTerminal (see Figure 7-4 for example). It is best to start by downloading the default DAS configuration, getting familiar with its command structure and syntax conventions, and then altering a copy of the original file offline before uploading the new configuration.



```
Instrument - HyperTerminal
File Edit View Call Transfer Help
[Icons]
SETUP PROPERTIES FOR ENGDAT:
NAME: ENGDAT
EVENT: ATIMER
REPORT PERIOD: 000:00:02
NUMBER OF RECORDS: 2000
RS-232 REPORT: ON
CHANNEL ENABLED: ON
CAL. HOLD OFF: OFF
PARAMETERS: 14
PARAMETER=RCTEMP, MODE=AVG, PRECISION=4, STORE_SAMPLES=OFF
PARAMETER=CNVTMP, MODE=AVG, PRECISION=4, STORE_SAMPLES=OFF
PARAMETER=PMTTMP, MODE=AVG, PRECISION=4, STORE_SAMPLES=OFF
PARAMETER=BOXTMP, MODE=AVG, PRECISION=4, STORE_SAMPLES=OFF
PARAMETER=O3FLOW, MODE=AVG, PRECISION=4, STORE_SAMPLES=OFF
PARAMETER=SMPFLW, MODE=AVG, PRECISION=4, STORE_SAMPLES=OFF
PARAMETER=SMPPRS, MODE=AVG, PRECISION=4, STORE_SAMPLES=OFF
PARAMETER=RCPRES, MODE=AVG, PRECISION=4, STORE_SAMPLES=OFF
PARAMETER=AZERO, MODE=AVG, PRECISION=4, STORE_SAMPLES=OFF
PARAMETER=HVPS, MODE=AVG, PRECISION=4, STORE_SAMPLES=OFF
PARAMETER=PMTDET, MODE=AVG, PRECISION=4, STORE_SAMPLES=OFF
PARAMETER=RF4096, MODE=AVG, PRECISION=4, STORE_SAMPLES=OFF
PARAMETER=REFGND, MODE=AVG, PRECISION=4, STORE_SAMPLES=OFF
Connected 00:01:32 Auto detect TCP/IP SCROLL CAPS NUM Capture Print echo
```

Figure 7-4: DAS Configuration Through a Terminal Emulation Program

See Section 8.2.1 for configuration commands and their strict syntax. Commands can be pasted in from of an existing text file, which was first edited offline and then uploaded through a specific transfer procedure.

IMPORTANT

IMPACT ON READINGS OR DATA

Whereas the editing, adding and deleting of DAS channels and parameters of one channel through the front-panel control buttons can be done without affecting the other channels, uploading a DAS configuration script to the analyzer through its communication ports will erase all data, parameters and channels by replacing them with the new DAS configuration. Backup of data and the original DAS configuration is advised before attempting any DAS changes.

This page intentionally left blank.

8. REMOTE OPERATION

This section provides information needed when using external digital and serial I/O for remote operation. It assumes that the electrical connections have been made as described in Section 3.3.1.

The T100 can be remotely configured, calibrated or queried for stored data through the serial ports, via either **Computer mode** (using a personal computer) or **Interactive mode** (using a terminal emulation program).

8.1. COMPUTER MODE

Computer Mode is used when the analyzer is connected to a computer with a dedicated interface program such as APICOM.

8.1.1. REMOTE CONTROL VIA APICOM

APICOM is an easy-to-use, yet powerful interface program that allows the user to access and control any of TAI's' main line of ambient and stack-gas instruments from a remote connection through direct cable, modem or Ethernet. Running APICOM, a user can:

- Establish a link from a remote location to the 9110T through direct cable connection via RS-232 modem or Ethernet.
- View the instrument's front panel and remotely access all functions that could be accessed manually on the instrument.
- Remotely edit system parameters and set points.
- Download, view, graph and save data for predictive diagnostics or data analysis.
- Retrieve, view, edit, save and upload DAS configurations (Section 7.2.1).
- Check on system parameters for troubleshooting and quality control.

APICOM is very helpful for initial setup, data analysis, maintenance and troubleshooting. Refer to the APICOM manual available for download from <http://www.teledyne-api.com/software/apicom/>.

8.2. INTERACTIVE MODE

Interactive mode is used with a terminal emulation programs or a "dumb" computer terminal.

8.2.1. REMOTE CONTROL VIA A TERMINAL EMULATION PROGRAM

Start a terminal emulation programs such as HyperTerminal. All configuration commands must be created following a strict syntax or be pasted in from a text file, which was edited offline and then uploaded through a specific transfer procedure. The commands that are used to operate the analyzer in this mode are listed in Table 8-1 and in Appendix A.

8.2.1.1. Help Commands in Interactive Mode

Table 8-1: Terminal Mode Software Commands

COMMAND	Function
Control-T	Switches the analyzer to terminal mode (echo, edit). If mode flags 1 & 2 are OFF, the interface can be used in interactive mode with a terminal emulation program.
Control-C	Switches the analyzer to computer mode (no echo, no edit).
CR (carriage return)	A carriage return is required after each command line is typed into the terminal/computer. The command will not be sent to the analyzer to be executed until this is done. On personal computers, this is achieved by pressing the ENTER button.
BS (backspace)	Erases one character to the left of the cursor location.
ESC (escape)	Erases the entire command line.
?[ID] CR	This command prints a complete list of available commands along with the definitions of their functionality to the display device of the terminal or computer being used. The ID number of the analyzer is only necessary if multiple analyzers are on the same communications line, such as the multi-drop setup.
Control-C	Pauses the listing of commands.
Control-P	Restarts the listing of commands.

8.2.1.2. Command Syntax

Commands are not case-sensitive and all arguments within one command (i.e. ID numbers, key words, data values, etc.) must be separated with a space character.

All Commands follow the syntax:

X [ID] COMMAND <CR>

Where:

- X** is the command type (one letter) that defines the type of command. Allowed designators are listed in Table 8-2 and Appendix A-6.
- [ID]** is the machine identification number (Section 5.7.1). Example: the Command “? 200” followed by a carriage return would print the list of available commands for the revision of software currently installed in the instrument assigned ID Number 200.
- COMMAND** is the command designator: This string is the name of the command being issued (LIST, ABORT, NAME, EXIT, etc.). Some commands may have additional arguments that define how the command is to be executed. Press ? <CR> or refer to Appendix A-6 for a list of available command designators
- <CR>** is a carriage return. All commands must be terminated by a carriage return (usually achieved by pressing the ENTER button on a computer).

Table 8-2: Teledyne API's Serial I/O Command Types

COMMAND	COMMAND TYPE
C	Calibration
D	Diagnostics

L	Logon
T	Test measurement
V	Variable
W	Warning

8.2.1.3. Data Types

Data types consist of integers, hexadecimal integers, floating-point numbers, Boolean expressions and text strings.

Integer data are used to indicate integral quantities such as a number of records, a filter length, etc. They consist of an optional plus or minus sign, followed by one or more digits. For example, +1, -12, 123 are all valid integers.

Hexadecimal integer data are used for the same purposes as integers. They consist of the two characters “0x,” followed by one or more hexadecimal digits (0-9, A-F, a-f), which is the ‘C’ programming language convention. No plus or minus sign is permitted. For example, 0x1, 0x12, 0x1234abcd are all valid hexadecimal integers.

Floating-point numbers are used to specify continuously variable values such as temperature set points, time intervals, warning limits, voltages, etc. They consist of an optional plus or minus sign, followed by zero or more digits, an optional decimal point and zero or more digits. (At least one digit must appear before or after the decimal point.) Scientific notation is not permitted. For example, +1.0, 1234.5678, -0.1, 1 are all valid floating-point numbers.

Boolean expressions are used to specify the value of variables or I/O signals that may assume only two values. They are denoted by the key words ON and OFF.

Text strings are used to represent data that cannot be easily represented by other data types, such as data channel names, which may contain letters and numbers. They consist of a quotation mark, followed by one or more printable characters, including spaces, letters, numbers, and symbols, and a final quotation mark. For example, “a”, “1”, “123abc”, and “()[]<>” are all valid text strings. It is not possible to include a quotation mark character within a text string.

Some commands allow you to access variables, messages, and other items. When using these commands, you must type the entire name of the item; you cannot abbreviate any names.

8.2.1.4. Status Reporting

Reporting of status messages as an audit trail is one of the three principal uses for the RS-232 interface (the other two being the command line interface for controlling the instrument and the download of data in electronic format). You can effectively disable the reporting feature by setting the interface to quiet mode (Section 6.2.1, Table 6-1).

Status reports include warning messages, calibration and diagnostic status messages. Refer to Appendix A-3 for a list of the possible messages, and this for information on controlling the instrument through the RS-232 interface.

8.2.1.5. General Message Format

All messages from the instrument (including those in response to a command line request) are in the format:

X DDD:HH:MM [Id] MESSAGE<CRLF>

Where:

X	is a command type designator, a single character indicating the message type, as shown in the Table 8-2.
DDD:HH:MM	is the time stamp, the date and time when the message was issued. It consists of the Day-of-year (DDD) as a number from 1 to 366, the hour of the day (HH) as a number from 00 to 23, and the minute (MM) as a number from 00 to 59.
[ID]	is the analyzer ID, a number with 1 to 4 digits.
MESSAGE	is the message content that may contain warning messages, test measurements, variable values, etc.
<CRLF>	is a carriage return / line feed pair, which terminates the message.

The uniform nature of the output messages makes it easy for a host computer to parse them into an easy structure. Keep in mind that the front panel display does not give any information on the time a message was issued, hence it is useful to log such messages for troubleshooting and reference purposes. Terminal emulation programs such as HyperTerminal can capture these messages to text files for later review.

8.3. REMOTE ACCESS BY MODEM

The 9110T can be connected to a modem for remote access. This requires a cable between the analyzer's COMM port and the modem, typically a DB-9F to DB-25M cable (available from TAI with P/N WR0000024).

Once the cable has been connected, check to ensure that:

- The DTE-DCE is in the DCE position.
- The 9110T COMM port is set for a baud rate that is compatible with the modem,
- The Modem is designed to operate with an 8-bit word length with one stop bit.
- The **MODEM ENABLE** communication mode is turned **ON** (Mode 64, see Section 6.2.1).

Once this is completed, the appropriate setup command line for your modem can be entered into the analyzer. The default setting for this feature is:

AT Y0 D0 H0 I0 S0=0

This string can be altered to match your modem's initialization and can be up to 100 characters long.

To change this setting press:

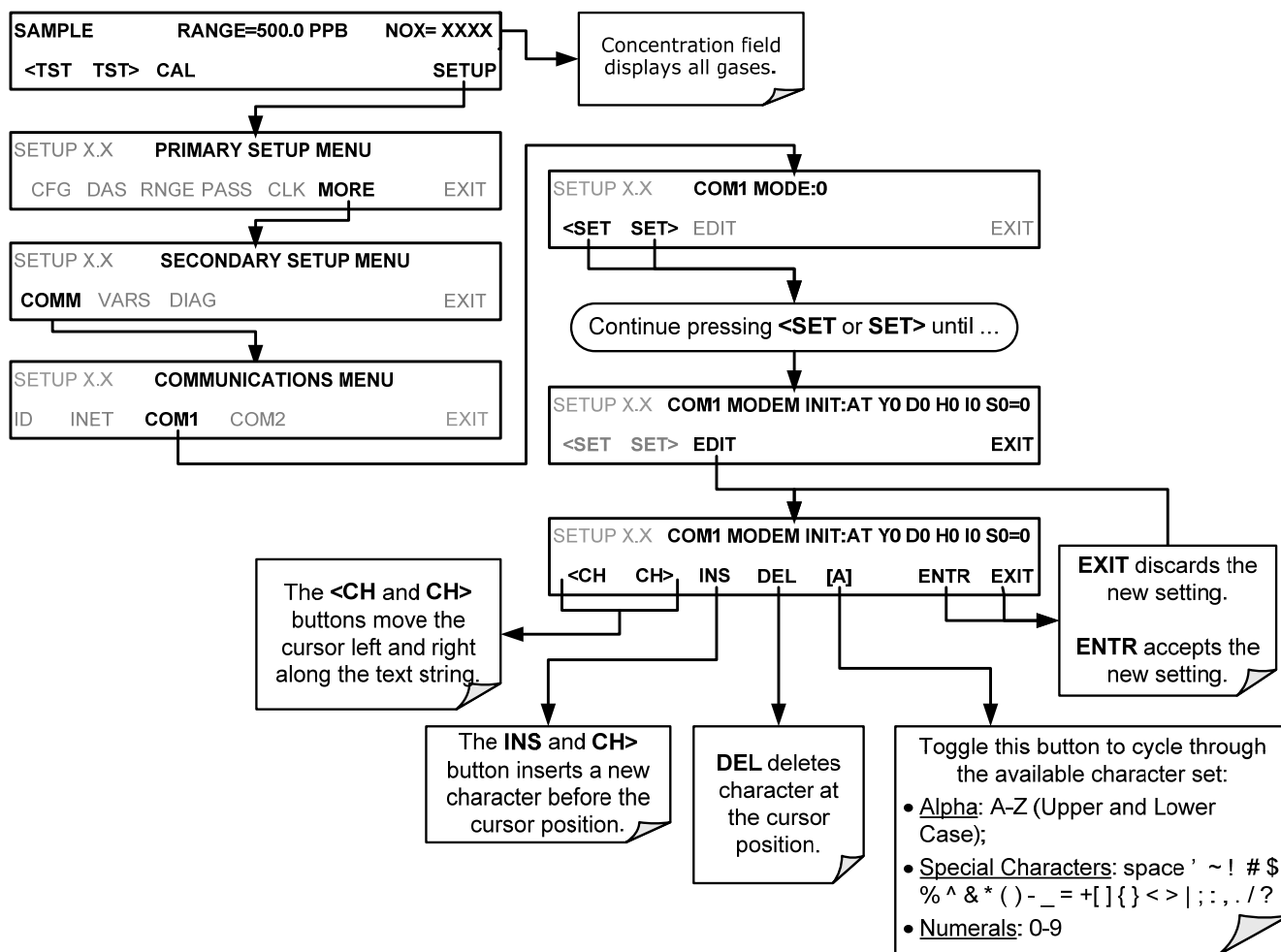
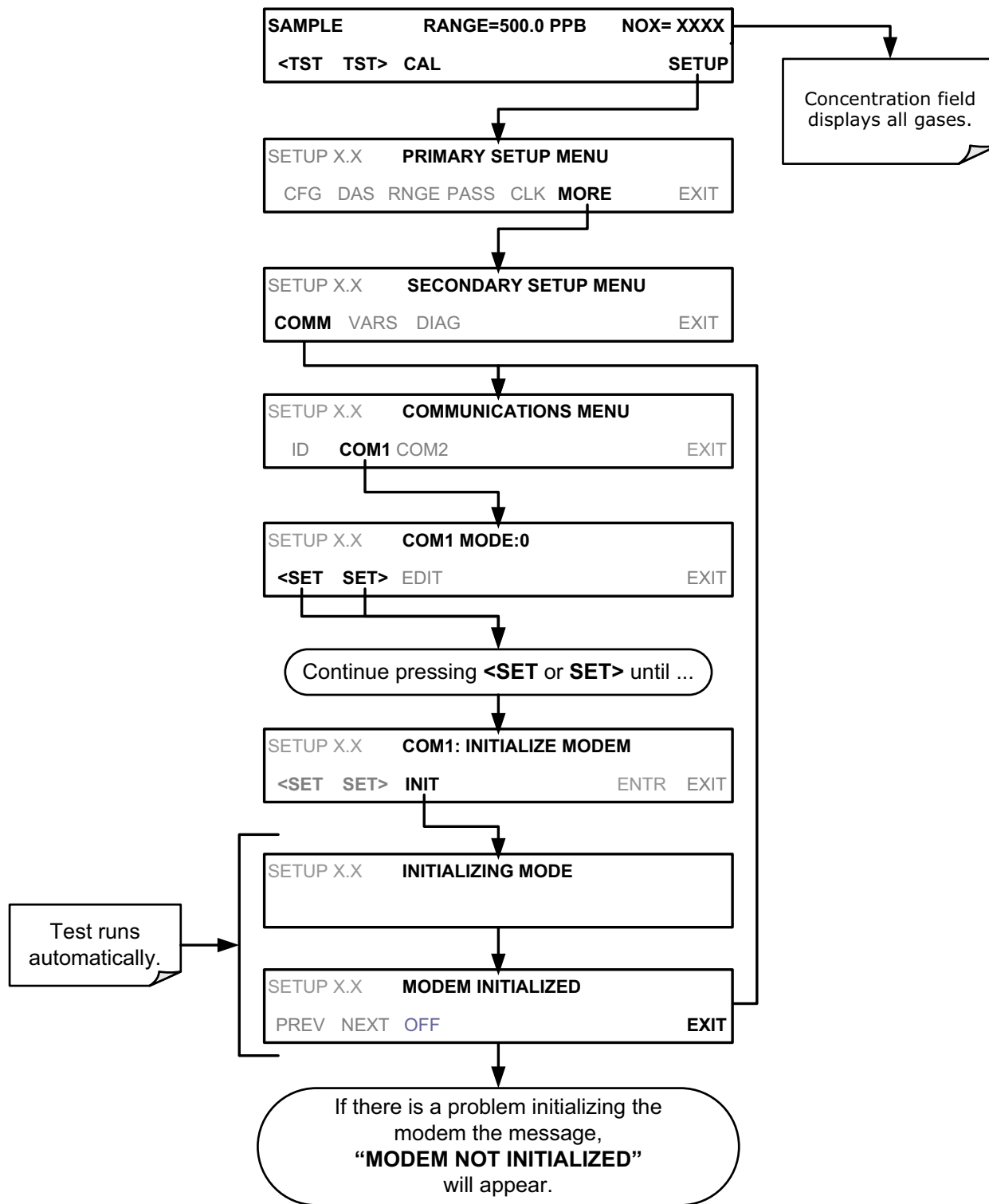

Figure 8-1: Remote Access by Modem

To initialize the modem press:



8.4. PASSWORD SECURITY FOR SERIAL REMOTE COMMUNICATIONS

In order to provide security for remote access of the 9110T, a LOGON feature can be enabled to require a password before the instrument will accept commands. This is done by turning on the **SECURITY MODE** (refer to Section 5.5). Once the **SECURITY MODE** is enabled, the following items apply.

- A password is required before the port will respond or pass on commands.
- If the port is inactive for one hour, it will automatically logoff, which can also be achieved with the LOGOFF command.
- Three unsuccessful attempts to log on with an incorrect password will cause subsequent logins to be disabled for 1 hour, even if the correct password is used.
- If not logged on, the only active command is the '?' request for the help screen.
- The following messages will be returned at logon:
 - LOGON SUCCESSFUL - Correct password given
 - LOGON FAILED - Password not given or incorrect
 - LOGOFF SUCCESSFUL - Connection terminated successfully

To log on to the 9110T analyzer with **SECURITY MODE** feature enabled, type:

```
LOGON 940331
```

940331 is the default password. To change the default password, use the variable RS-232_PASS issued as follows:

```
V RS-232_PASS=NNNNNN
```

Where N is any numeral between 0 and 9.

This page intentionally left blank.

9. CALIBRATION PROCEDURES

This section contains information for calibrating a 9110T NO_x Analyzer as well as other supporting information. For information on EPA protocol calibration, please refer to Section 10. This section is organized as follows:

SECTION 9.1 – Before Calibration

This section contains general information you should know before about calibrating the analyzer.

SECTION 9.2 – Manual Calibration Checks and Calibration of the 9110T Analyzer in its Base Configuration

This section describes:

- The procedure for checking the calibrating of the 9110T and calibrating the instrument with no zero/span valves installed or if installed, not operating. It requires that zero air and span gas be installed through the Sample port.
- Instructions for selecting the reporting range to be calibrated when the 9110T analyzer is set to operate in either the IND or AUTO reporting range modes.

SECTION 9.3 – Manual Calibration with the Internal Span Gas Generator

This section describes:

- The procedure for manually checking the calibration of the instrument with optional internal span gas generator installed.
- The procedure for manually calibrating the instrument using the optional internal span gas generator.
 - This practice is not approved by the US EPA.

SECTION 9.4 – Manual Calibration and Cal Checks with the Valve Options Installed

This section describes:

- The procedure for manually checking the calibration of the instrument with optional zero/span valves option installed.
- The procedure for manually calibrating the instrument with zero/span valves and operating.
- Instructions on activating the zero/span valves via the control in contact closures of the analyzers external digital I/O.

SECTION 9.5 – Automatic Zero/Span Cal/Check (AutoCal)

This section describes:

- The procedure for using the AutoCal feature of the analyzer to check or calibrate the instrument.
- The AutoCal feature requires that either the zero/span valve option or the internal span gas generator option be installed and operating.

SECTION 9.6 – Calibration Quality Analysis

This section describes how to judge the effectiveness of a recently performed calibration.

SECTION 9.7 – Gas Flow Calibration

This section describes how to adjust the gas flow calculations made by the CPU based on pressure and flow sensor readings.

Note

Throughout this Section are various diagrams showing pneumatic connections between the 9110T and various other pieces of equipment such as calibrators and zero air sources.

These diagrams are only intended to be schematic representations of these connections and do not reflect actual physical locations of equipment and fitting location or orientation.

Contact your regional EPA or other appropriate governing agency for more detailed recommendations.

9.1. BEFORE CALIBRATION

The calibration procedures in this section assume that the range mode, analog range and units of measure have already been selected for the analyzer. If this has not been done, please do so before continuing (see Section 5.4.3 for instructions).

Note

If any problems occur while performing the following calibration procedures, refer to Section 12.1 for troubleshooting tips.

9.1.1. REQUIRED EQUIPMENT, SUPPLIES, AND EXPENDABLES

Calibration of the 9110T NO_x Analyzer requires:

- Zero-air source.
- Span gas source.
- Gas lines - all gas line materials should be stainless steel or Teflon-type (PTFE or FEP).
 - High-concentration NO gas transported over long distances may require stainless steel to avoid oxidation of NO due to the possibility of O₂ diffusing into the tubing.
- A recording device such as a strip-chart recorder and/or data logger (optional).
- For electronic documentation, the internal data acquisition system (DAS) can be used.

9.1.2. CALIBRATION GASES

9.1.2.1. Zero Air

Zero air or zero calibration gas is defined as a gas that is similar in chemical composition to the measured medium but without the gas to be measured by the analyzer.

For the 9110T, this means zero air should be devoid of NO, NO₂, CO₂, NH₃ or H₂O vapor.

Note

Moderate amounts of NH₃ and H₂O can be removed from the sample gas stream by installing the optional sample gas dryer/scrubber (see Section 3.3.2.6).

- If your application is not a measurement in ambient air, the zero calibration gas should be matched to the composition of the gas being measured.
- Pure nitrogen (N₂) could be used as a zero gas for applications where NO_x is measured in nitrogen.
- If your analyzer is equipped with an external zero air scrubber option, it is capable of creating zero air from ambient air.

For analyzers without the external zero air scrubber, a zero air generator such as the Teledyne Model 701 can be used. Please visit the company website for more information.

If your analyzer is equipped with an external zero air scrubber option, it is capable of creating zero air from ambient air.

- If your application is not a measurement in ambient air, the zero calibration gas should be matched to the composition of the gas being measured.
- Pure nitrogen could be used as a zero gas for applications where NO_x is measured in nitrogen.

9.1.2.2. Span Gas

Calibration gas is a gas specifically mixed to match the chemical composition of the type of gas being measured at near full scale of the desired reporting range. To measure NO_x with the 9110T NO_x analyzer, it is recommended that you use a span gas with an NO concentration equal to 80% of the measurement range for your application

EXAMPLE:

- If the application is to measure NO_x in ambient air between 0 ppm and 500 ppb, an appropriate span gas would be 400 ppb.
- If the application is to measure NO_x in ambient air between 0 ppm and 1000 ppb, an appropriate span gas would be 800 ppb.

We strongly recommend that span calibration be carried out with NO span gas. Alternatively it is possible to use NO₂ gas in a gas phase titration (GPT) calibration system (see Section 10.5).

Even though NO gas mixed into in nitrogen gas (N₂) could be used as a span gas, the matrix of the balance gas is different and may cause interference problems or yield incorrect calibrations.

- The same applies to gases that contain high concentrations of other compounds (for example, CO₂ or H₂O).

Note

The span gas should match all concentrations of all gases of the measured medium as closely as possible.

Cylinders of calibrated NO_x and NO gas traceable to NIST-standards specifications (also referred to as EPA protocol calibration gases or Standard Reference Materials) are commercially available. For a list of these gases see Table 3-8).

9.1.2.3. Span Gas for Multipoint Calibration

Some applications, such as EPA monitoring, require a multipoint calibration where span gases of different concentrations are needed. We recommend using an NO gas of higher concentration combined with a gas dilution calibrator such as a Teledyne Model T700. For more information see Section 3.3.2.1 and Section 10.

9.1.2.4. NO₂ Permeation Tubes

TAI offers an optional internal span gas generator that utilizes an NO₂ permeation tube as a span gas source. The accuracy of these devices is only about ±5%.

Whereas this may be sufficient for quick, daily calibration checks, we recommend using certified NO gases for accurate calibration.

Note

The use of permeation tubes is not approved by the US EPA as calibration sources for performing actual calibration of the analyzers used in EPA mandated monitoring.

CAUTION!

Insufficient gas flow allows gas to build up to levels that will contaminate the instrument or present a safety hazard to personnel.



In units with a permeation tube option installed, either the tube must be removed and stored in sealed container (use original container that tube was shipped in) during periods of non-operation, or vacuum pump must be connected and powered on to maintain constant gas flow through the analyzer at all times.

(See Figure 3-6 for location and Section 11.3.6 for instructions on how to remove the perm tube when the unit is not in operation).

9.1.3. DATA RECORDING DEVICES

A strip chart recorder, data acquisition system or digital data acquisition system should be used to record data from the serial or analog outputs of the 9110T.

- If analog readings are used, the response of the recording system should be checked against a NIST traceable voltage source or meter.

- Data recording devices should be capable of bi-polar operation so that negative readings can be recorded.

For electronic data recording, the 9110T provides an internal data acquisition system (DAS), which is described in detail in Section 7.

APICOM, a remote control program, is also provided as a convenient and powerful tool for data handling, download, storage, quick check and plotting (see Sections 7.2.1, and the APICOM software manual downloadable from:

<http://www.tekedtbe-api.com/manuals>).

9.1.4. NO₂ CONVERSION EFFICIENCY (CE)

In order for the NO₂ converter to function properly, oxygen must be present in the sample stream. In addition, to ensure accurate operation of the 9110T, it is important to check the NO₂ conversion efficiency (CE) periodically and to update this value as necessary.

- See Section 12.7.10 for instructions on checking or calculating the current NO₂ → NO converter efficiency using 9110T's onboard firmware.
- See Section 12.7.11 for instructions on checking or calculating the current NO₂ → NO converter efficiency using a simplified Gas Phase Titration Method.

9.2. MANUAL CALIBRATION CHECKS AND CALIBRATION OF THE 9110T ANALYZER IN ITS BASE CONFIGURATION

IMPORTANT

IMPACT ON READINGS OR DATA

ZERO/SPAN CALIBRATION CHECKS VS. ZERO/SPAN CALIBRATION

Pressing the ENTR button during the following procedure resets the stored values for OFFSET and SLOPE and alters the instrument's Calibration.

This should **ONLY BE DONE** during an actual calibration of the 9110T.

NEVER press the ENTR button if you are only *checking* calibration..

9.2.1. SETUP FOR BASIC CALIBRATION CHECKS AND CALIBRATION OF THE 9110T ANALYZER.

Connect the sources of zero air and span gas as shown below in one of the following ways:

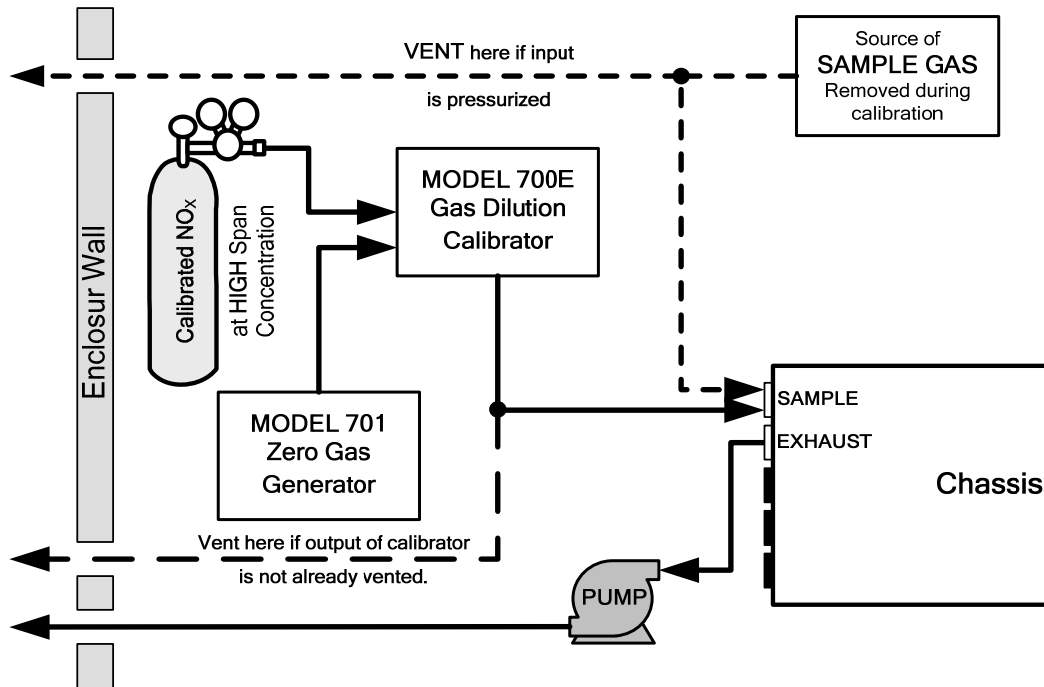

Figure 9-1: Set up for Manual Calibrations/Checks of 9110T's in Base Configuration w/ a Gas Dilution Calibrator

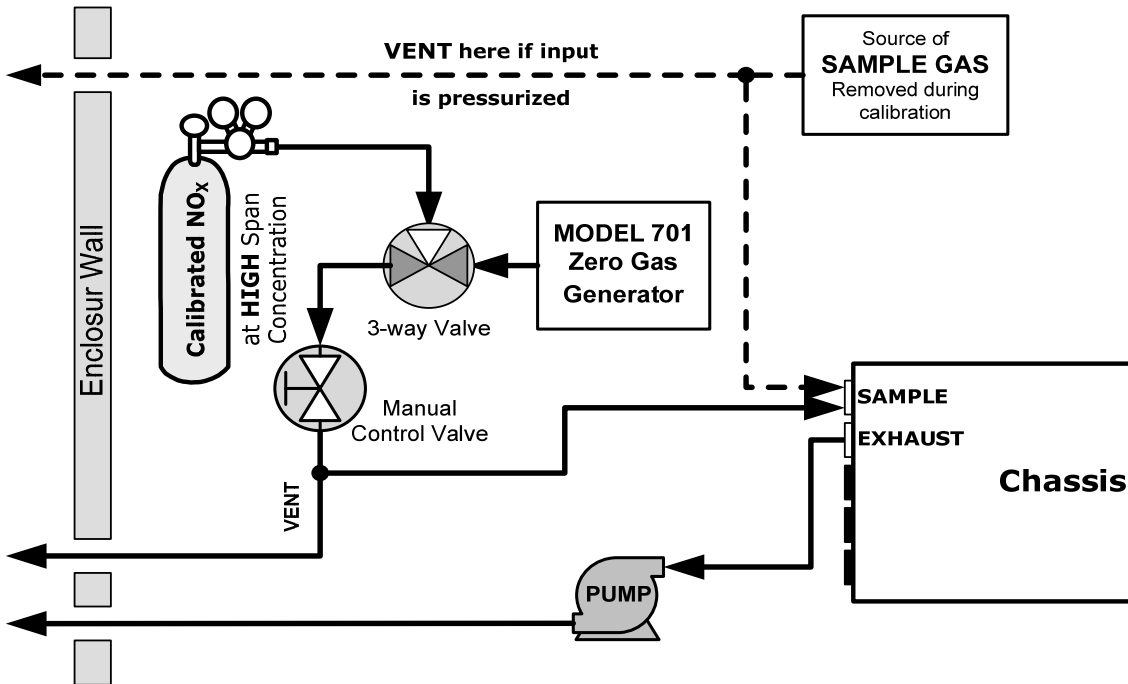
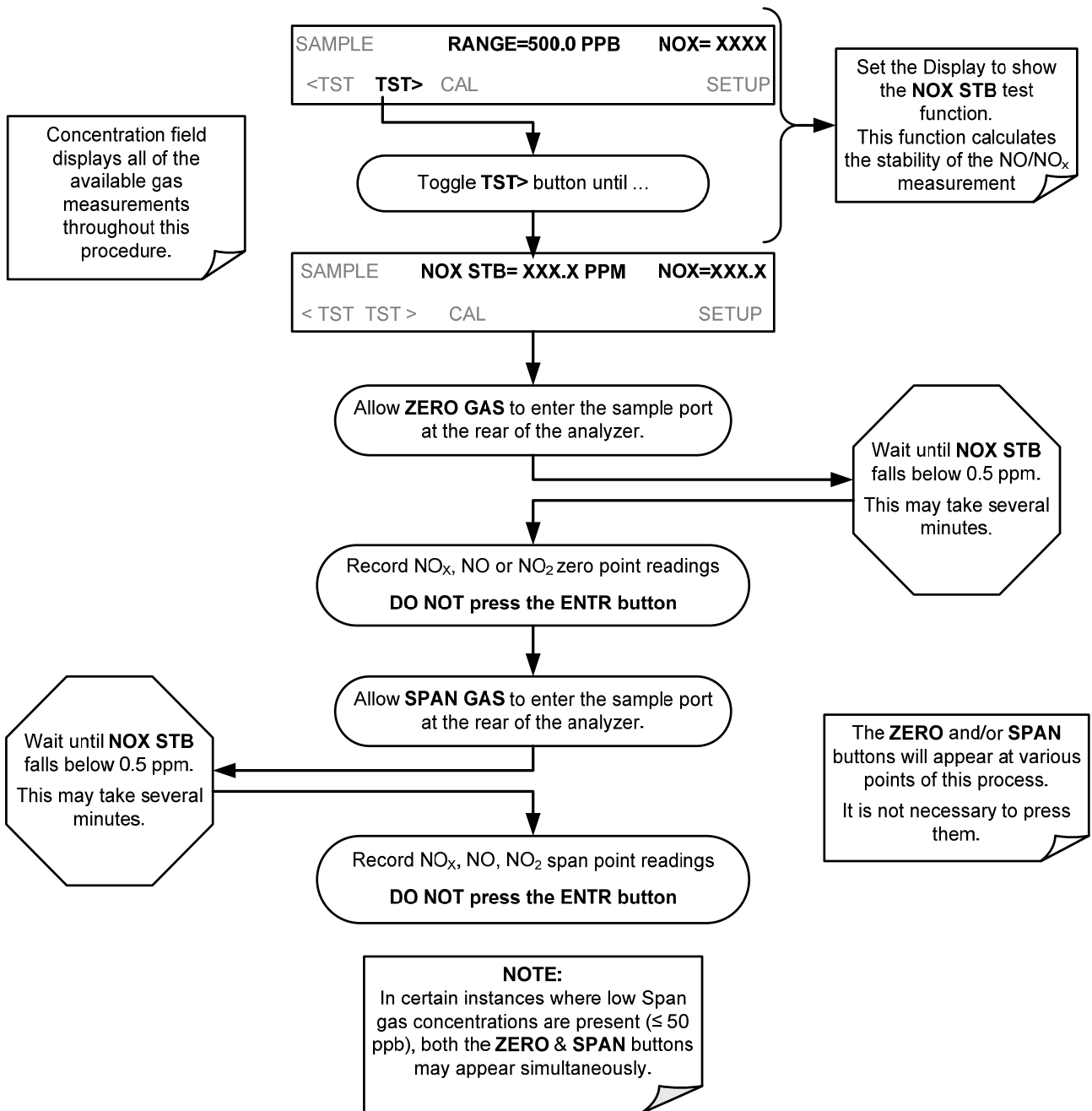

Figure 9-2: Set up for Manual Calibrations/Checks of 9110T's in Base Configuration w/ Bottled Gas

9.2.2. PERFORMING A BASIC MANUAL CALIBRATION CHECK



Note

If the **ZERO** or **SPAN** buttons are not displayed, the measurement made is outside the allowable range for a reliable calibration.

See Section 12 for troubleshooting tips.

9.2.3. PERFORMING A BASIC MANUAL CALIBRATION

The following section describes the basic method for manually calibrating the 9110T NO_x analyzer.

If the analyzer's reporting range is set for the **AUTO** range mode, a step will appear for selecting which range is to be calibrated (**LOW** or **HIGH**). Each of these two ranges **MUST** be calibrated separately.

9.2.3.1. Setting the Expected Span Gas Concentration

Note

The expected concentrations for both NOx and NO are usually set to the same value unless the conversion efficiency is not equal to 1.000 or not entered properly in the conversion efficiency setting.

When setting expected concentration values, consider impurities in your span gas source (e.g. NO often contains 1-3% NO2 and vice versa).

The NO and NO_x span gas concentrations should be 80% of range of concentration values likely to be encountered in your application. The default factory reporting range setting is 500 ppb and the default span gas concentration is 40.0 ppb.

To set the span gas concentration, press:

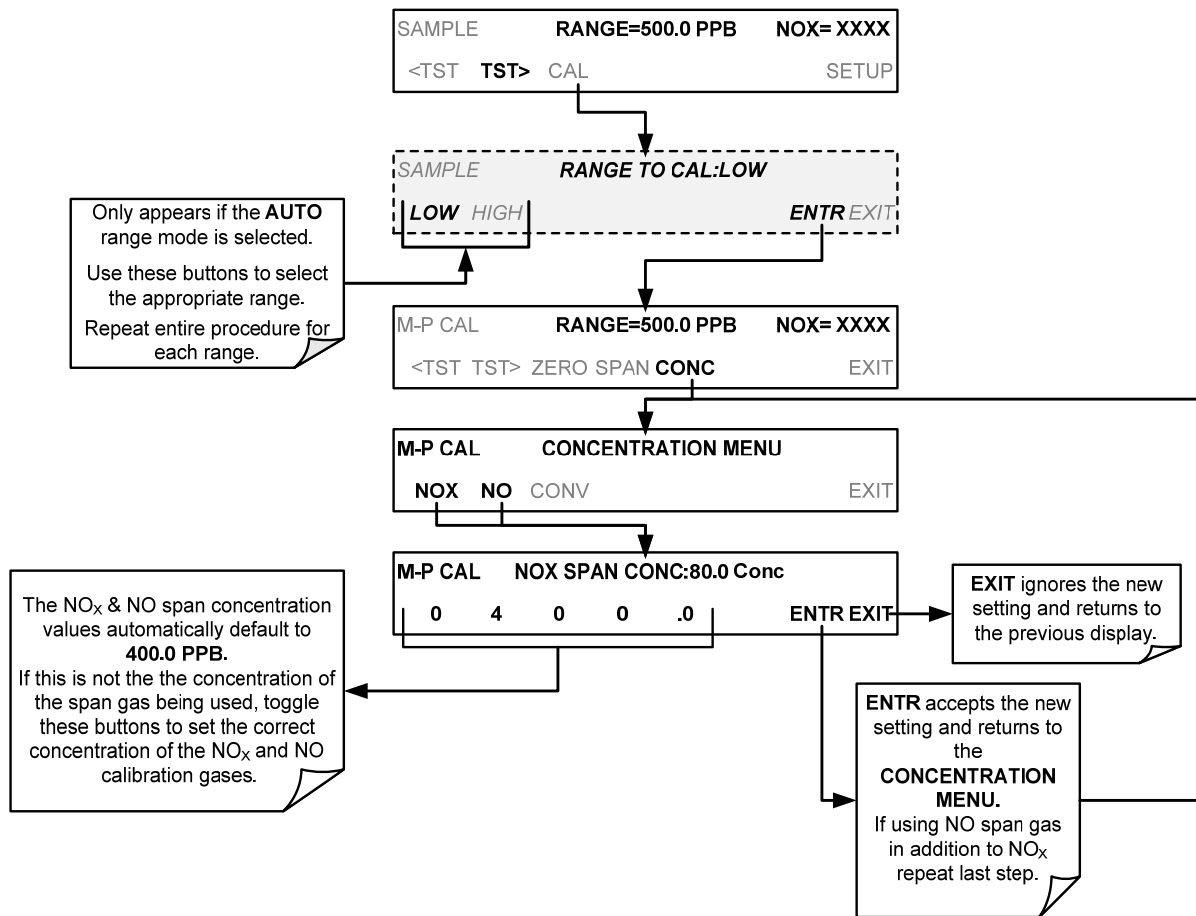

9.2.3.2. Zero/Span Point Calibration Procedure

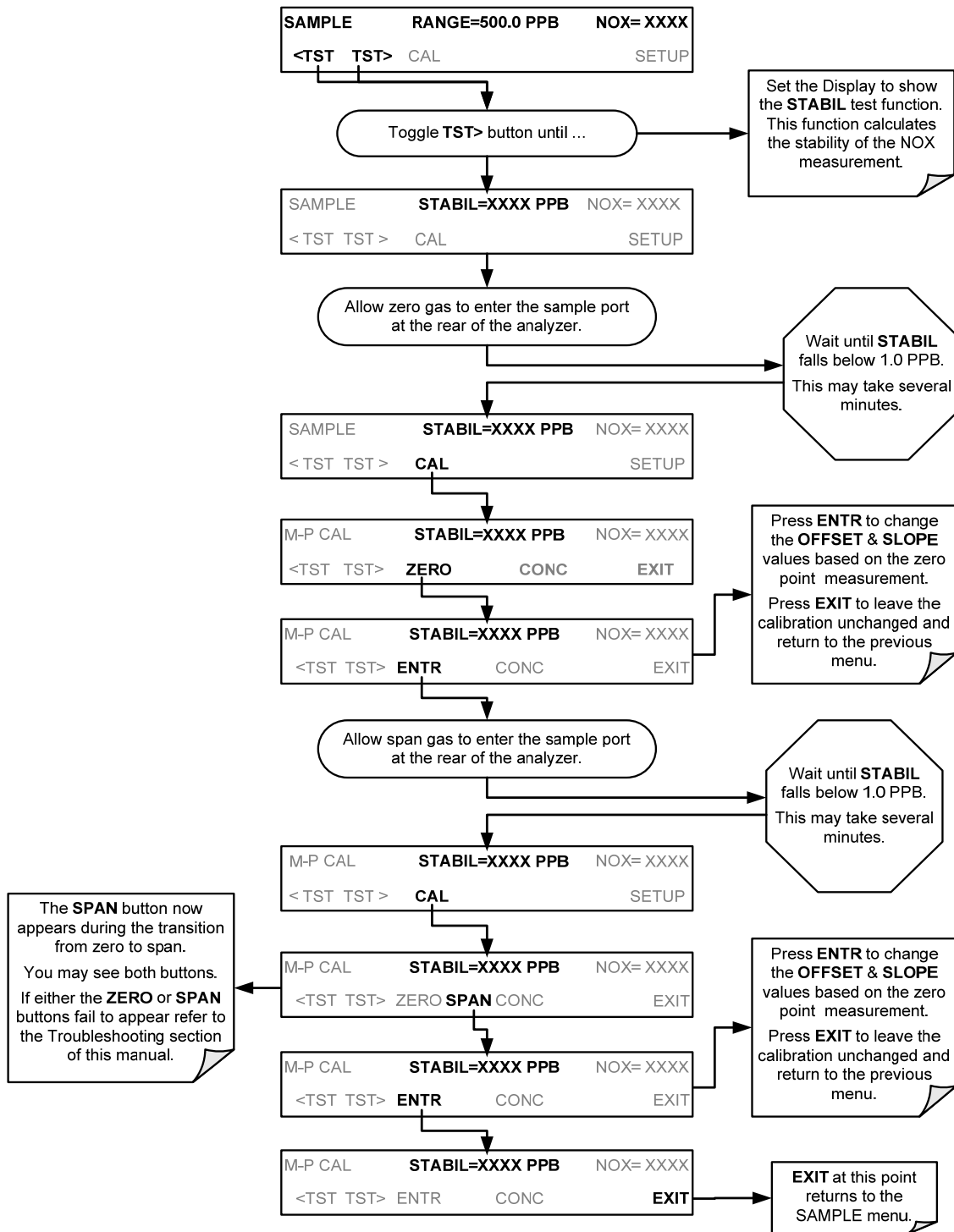

Note

If the **ZERO** or **SPAN** buttons are not displayed, the measurement made during is out of the allowable range allowed for a reliable calibration. See Section 12 for troubleshooting tips.

9.3. MANUAL CALIBRATION WITH THE INTERNAL SPAN GAS GENERATOR

IMPORTANT

IMPACT ON READINGS OR DATA

The internal span gas generator’s NO2 permeation tube has a limited accuracy of about ±5%. In the USA this may be sufficient for informal calibration *checks* (Section 9.3.4), but it is NOT approved by the US EPA as a calibration source.

9.3.1. PERFORMING “PRECISION” MANUAL CALIBRATION WHEN INTERNAL SPAN GAS (IZS) GENERATOR OPTION IS PRESENT

It is necessary to perform a precision calibration using more accurate zero and span gas standards prior to IZS span calibration or cal check.

To perform a precision calibration of the 9110T, connect external sources of zero air and calibrated span gas (Section 9.1.2) and temporarily disconnect the sample gas source as shown below; then follow the procedures described in Section 9.2.3.

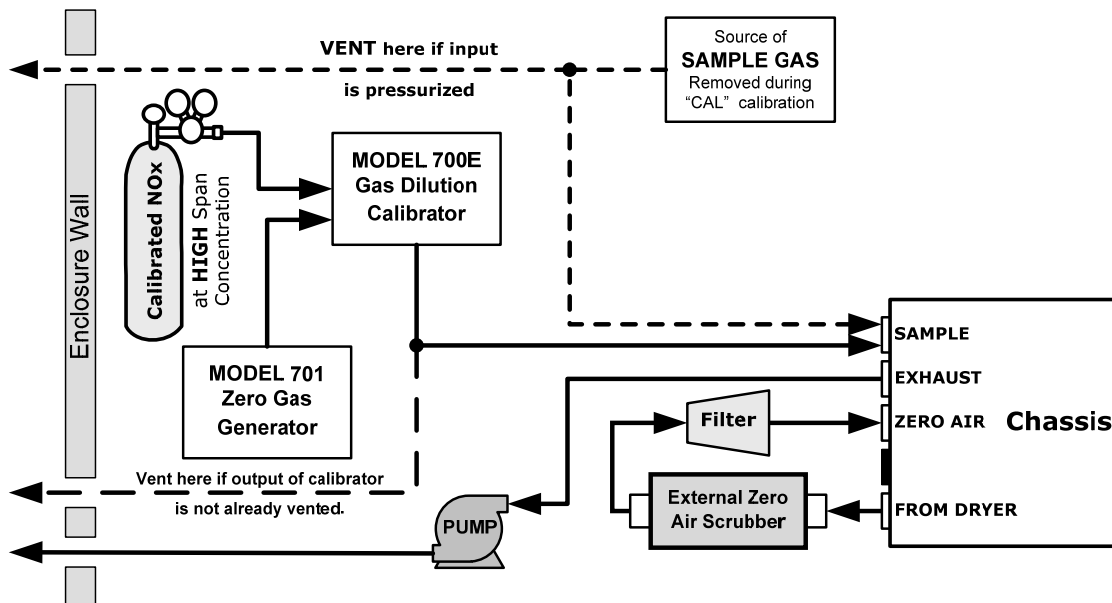

Figure 9-3: Pneumatic Connections for 9110T Precision Calibration when IZS Generator Present

IMPORTANT

IMPACT ON READINGS OR DATA

DO NOT USE THE CALZ or CALS buttons even though they will be visible, as this will cause the instrument to use the internal zero air and span gas. Instead, press the CAL button. This will cause the analyzer to use the external calibration gas sources.

9.3.2. SETUP FOR CALIBRATION WITH THE INTERNAL SPAN GAS GENERATOR

Connect the sources of zero air and span gas as shown in Figure 9-4.

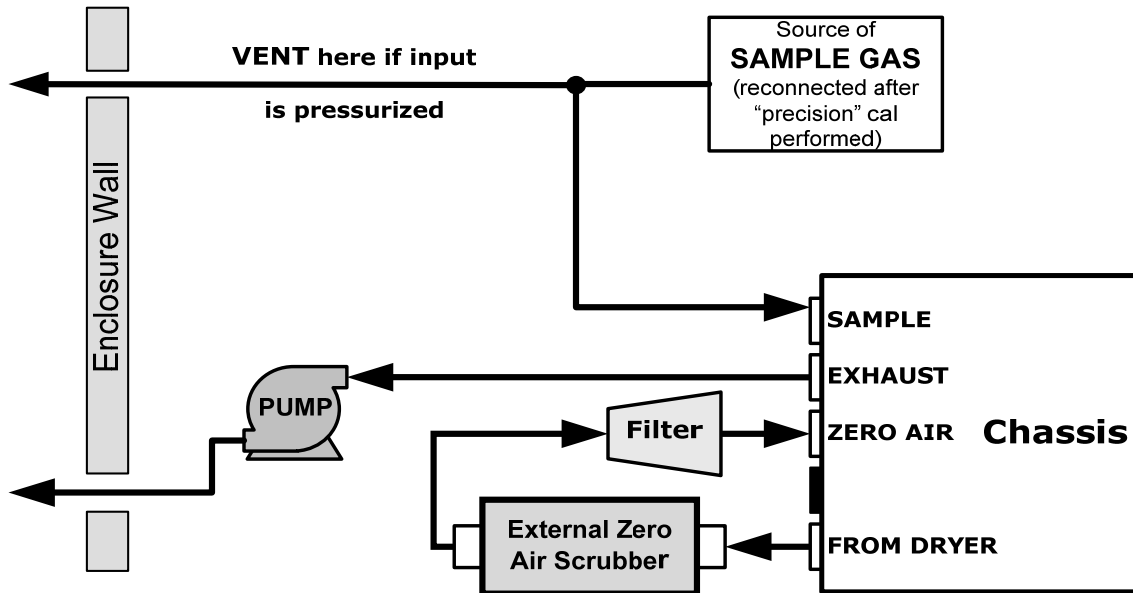

Figure 9-4: Pneumatic Connections for Manual Calibration/Checks with the Internal Span Gas Generator

9.3.3. CAL ON NO₂ FEATURE

When using the IZS option to calibrate the 9110T, the analyzer’s CAL_ON_NO₂ feature must be turned on. This feature enables a continuous zero gas flow across the IZS permeation tube and through the NO₂ converter. It also programs the analyzer to use the NO output from the NO₂ converter to calibrate the span value of both NO and NO_x.

Note

This feature should only be enabled when a span calibration or calibration check is performed.

While CAL_ON_NO₂ is enabled, the NO₂ concentration will always be reported as zero. This is because the gas is continuously routed through the NO₂ converter and the analyzer’s firmware simulates calibration with NO gas.

Table 9-1: IZS Option Valve States with CAL_ON_NO₂ Turned ON

Valve	Condition	Valve Port Connections
Sample/Cal	Open to zero/span valve	1 → 2
Zero/Span	Open to SPAN GAS inlet	1 → 2
NO/NO _x Valve	Open to NO ₂ converter	1 → 2
Auto Zero Valve	Cycles normally	N/A

Since the instrument sees the same concentration of NO during both NO and NO_x cycles, it reports an NO₂ concentration of zero.

TO turn the CAL_ON_NO₂ feature ON/OFF, press:

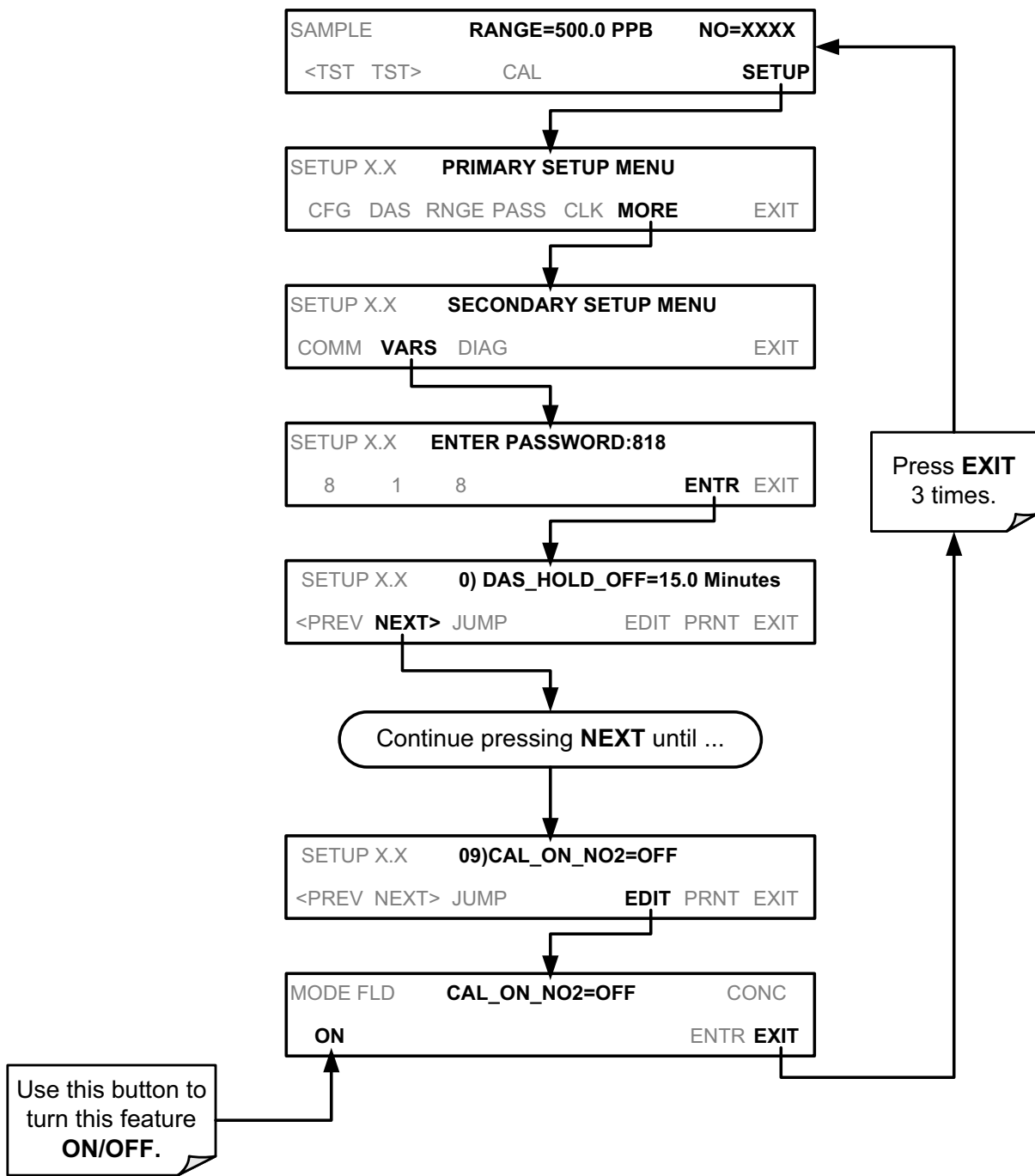

9.3.4. PERFORMING A MANUAL CALIBRATION CHECK WITH THE INTERNAL SPAN GAS GENERATOR

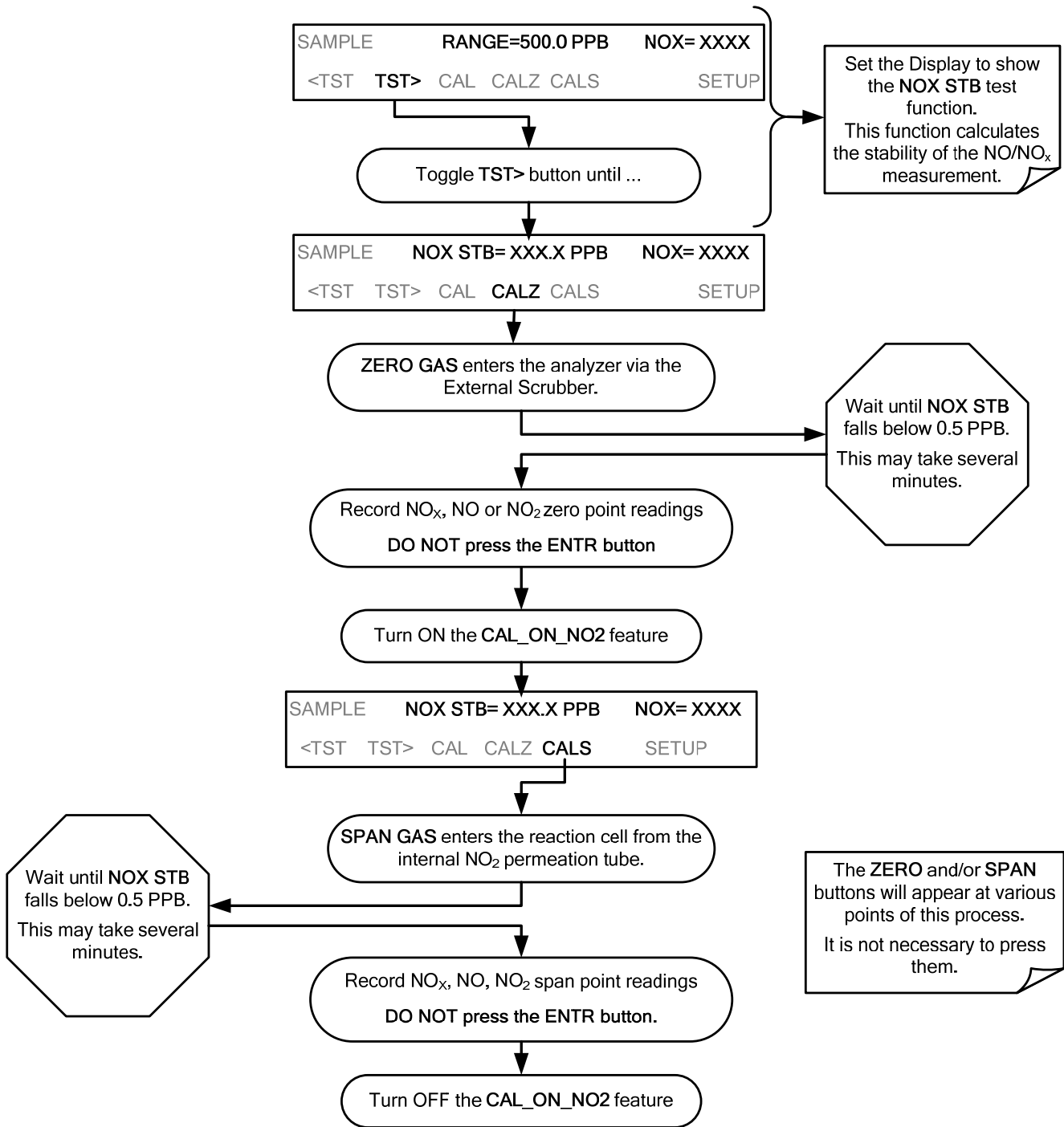

Note

If the ZERO or SPAN buttons are not displayed, the measurement made is out of the allowable range for a reliable calibration. See Section 12 for troubleshooting tips.

9.3.5. PERFORMING A MANUAL CALIBRATION WITH THE INTERNAL SPAN GAS GENERATOR

If the analyzer's reporting range is set for the **AUTO** range mode, a step will appear for selecting which range is to be calibrated (**LOW** or **HIGH**). Each of these two ranges *MUST be calibrated separately*.

9.3.5.1. Setting the Expected Span Gas Concentration

Note

The expected concentrations for both NOx and NO are usually set to the same value unless the conversion efficiency is not equal to 1.000 or not entered properly in the conversion efficiency setting.

When setting expected concentration values, consider impurities in your span gas source (e.g. NO often contains 1-3% NO₂ and vice versa).

When calibrating the instrument using the internal permeation tube as a span gas source, it is necessary to know, as close as possible, the concentration value of the gas being outputted by the tube. To determine this value:

1. Perform a precision calibration of the instrument as describes in Section 9.3.1.
3. Perform a calibration check as described in Section 9.3.4.
 - Record the value displayed for NO/NOx during the span check portion of the procedure.
 - This will be the concentration value used in subsequent calibrations using the internal span gas source.
 - It is a good idea to measure the permeation tube output once every 4 to 6 months.
4. Ensure that the reporting range span point is set for a value at least 10% higher than the measured value of the permeation tube output

To set the span gas concentration, press:

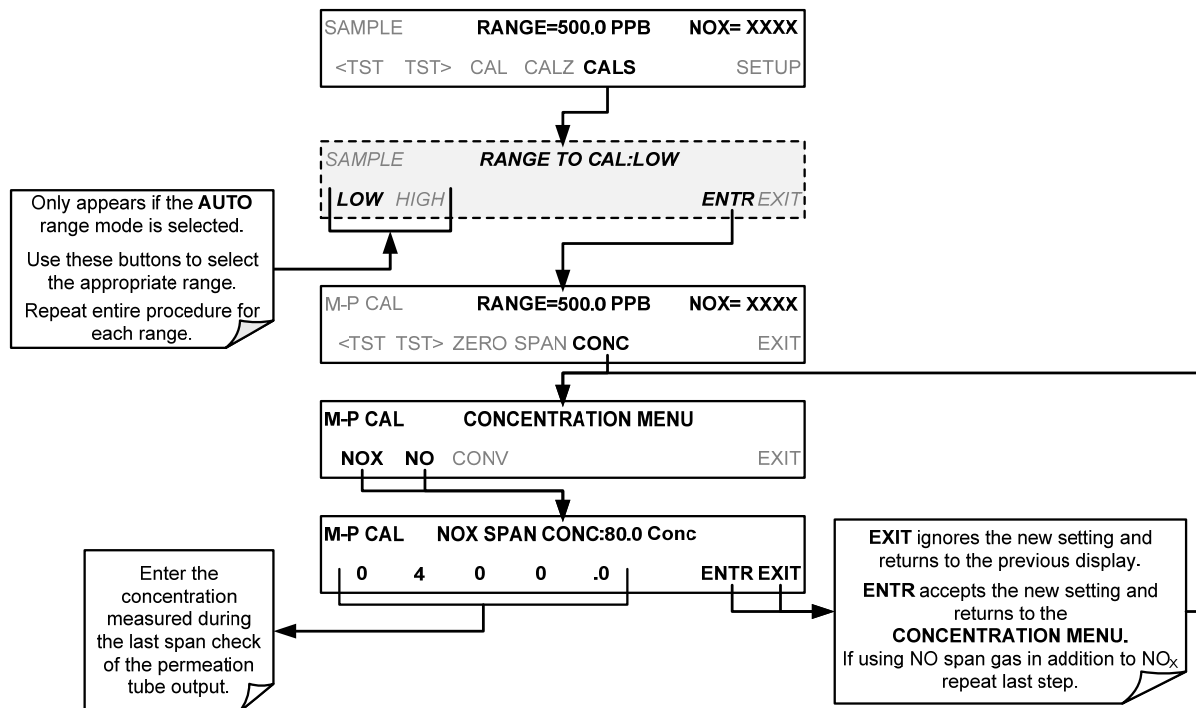

9.3.5.2. Zero/Span Point Calibration Procedure with Internal Span Gas Generator

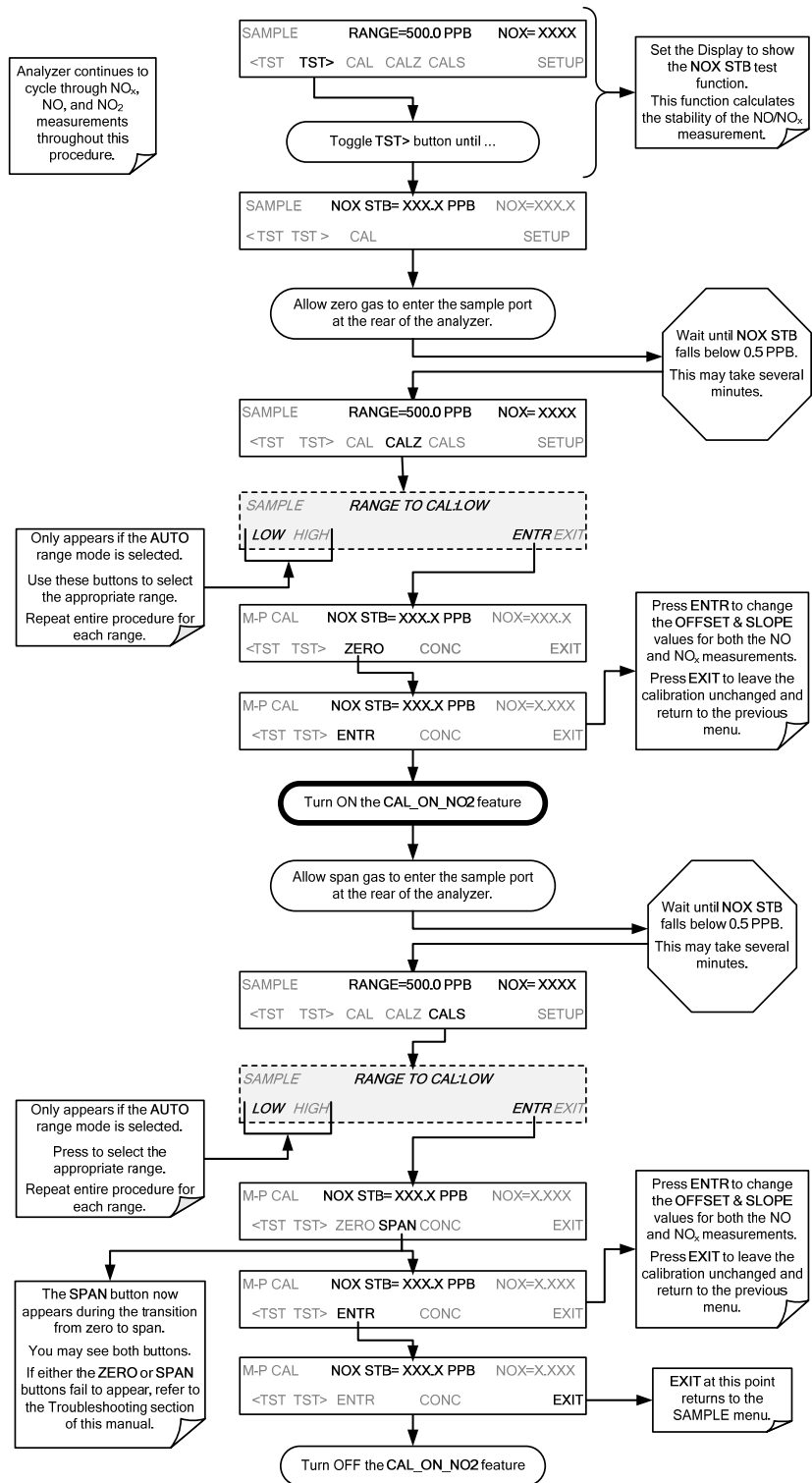

Note

If the ZERO or SPAN buttons are not displayed, the measurement made during during this procedure is out of the range allowed for a reliable calibration. See Section 12 for troubleshooting tips.

9.4. MANUAL CALIBRATION AND CAL CHECKS WITH THE VALVE OPTIONS INSTALLED

There are a variety of valve options available on the 9110T for handling calibration gases (see Section 1.4 for descriptions of each).

Generally performing calibration checks and zero/span point calibrations on analyzers with these options installed is similar to the methods discussed in the previous sections. The primary differences are:

- On instruments with Z/S valve options, zero air and span gas is supplied to the analyzer through other gas inlets besides the sample gas inlet.
- The zero and span calibration operations are initiated directly and independently with dedicated buttons (**CALZ** & **CALS**).

9.4.1. SETUP FOR CALIBRATION USING VALVE OPTIONS

Each of the various calibration valve options requires a different pneumatic setup that is dependent on the exact nature and number of valves present. Refer to the following diagrams for information on each or these valve sets.

9.4.2. MANUAL CALIBRATION CHECKS WITH VALVE OPTIONS INSTALLED

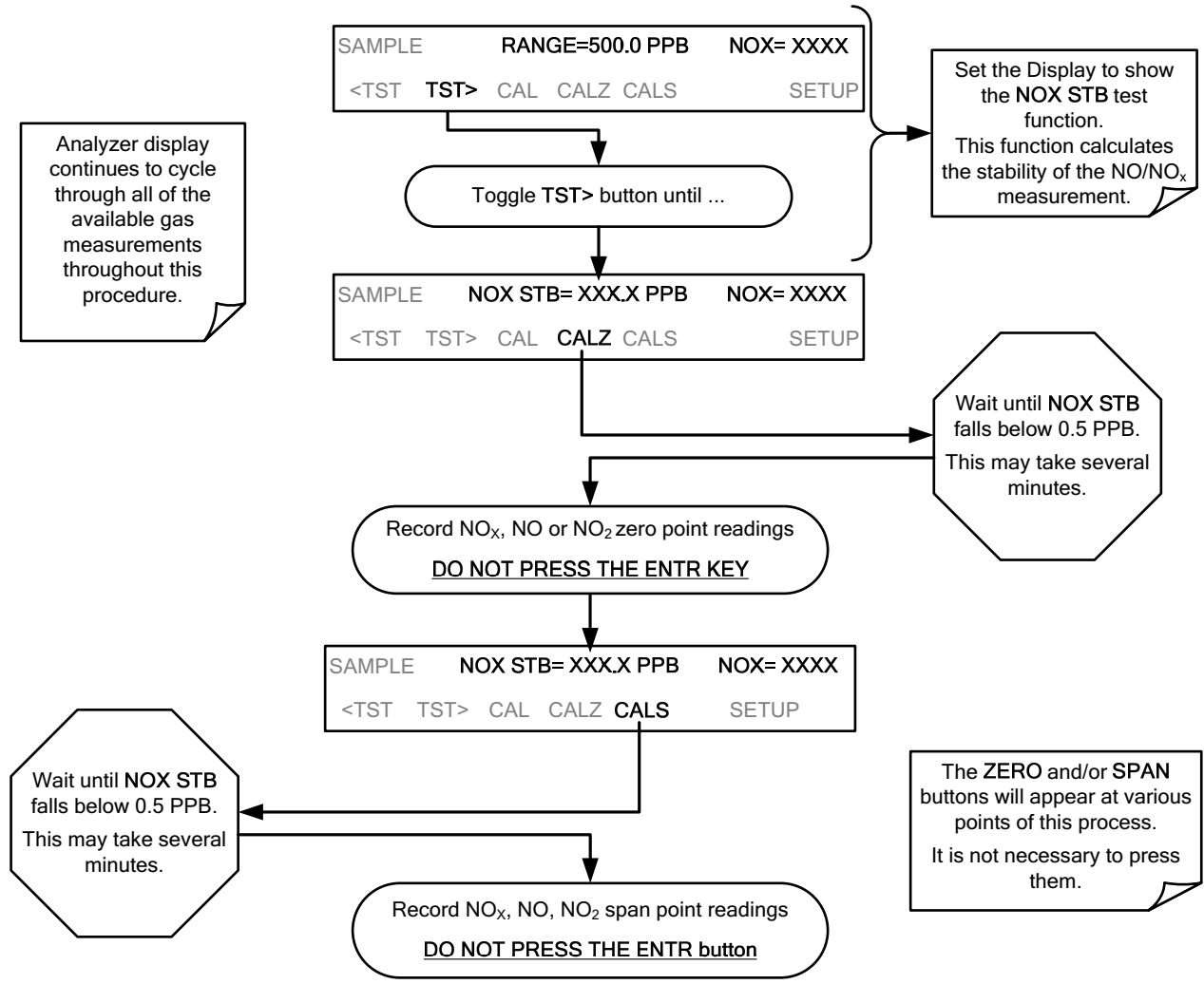

9.4.3. MANUAL CALIBRATION USING VALVE OPTIONS

The following section describes the basic method for manually calibrating the 9110T NO_x analyzer.

If the analyzer's reporting range is set for the **AUTO** range mode, a step will appear for selecting which range is to be calibrated (**LOW** or **HIGH**). Each of these two ranges *MUST be calibrated separately*.

9.4.3.1. Setting the Expected Span Gas Concentration

Note

The expected concentrations for both NO_x and NO are usually set to the same value unless the conversion efficiency is not equal to 1.000 or not entered properly in the conversion efficiency setting.

When setting expected concentration values, consider impurities in your span gas source (e.g. NO often contains 1-3% NO₂ and vice versa).

The NO and NO_x span gas concentrations should be 80% of range of concentration values likely to be encountered in your application. The default factory reporting range setting is 500 ppb and the default span gas concentration is 400.0 ppb.

To set the span gas concentration, press:

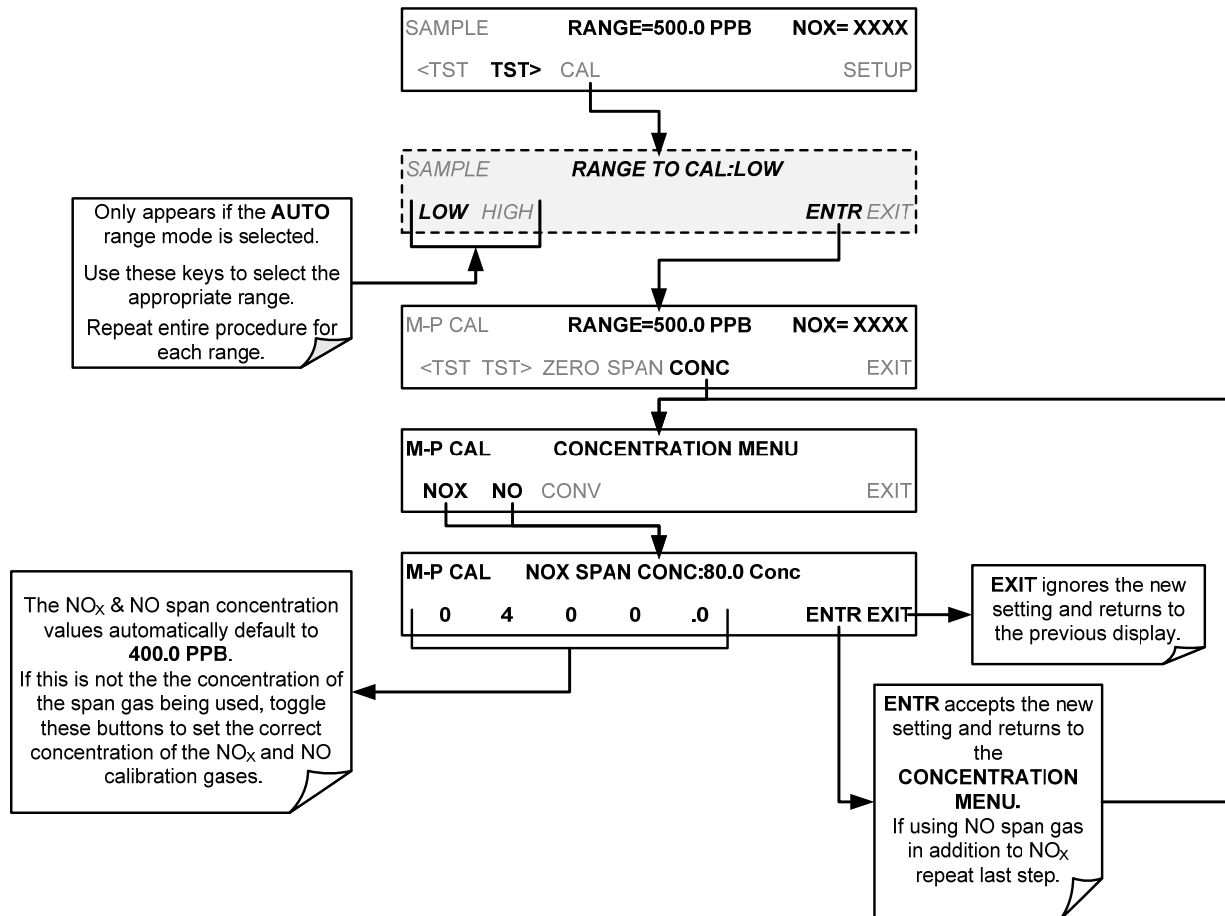

9.4.3.2. Zero/Span Point Calibration Procedure

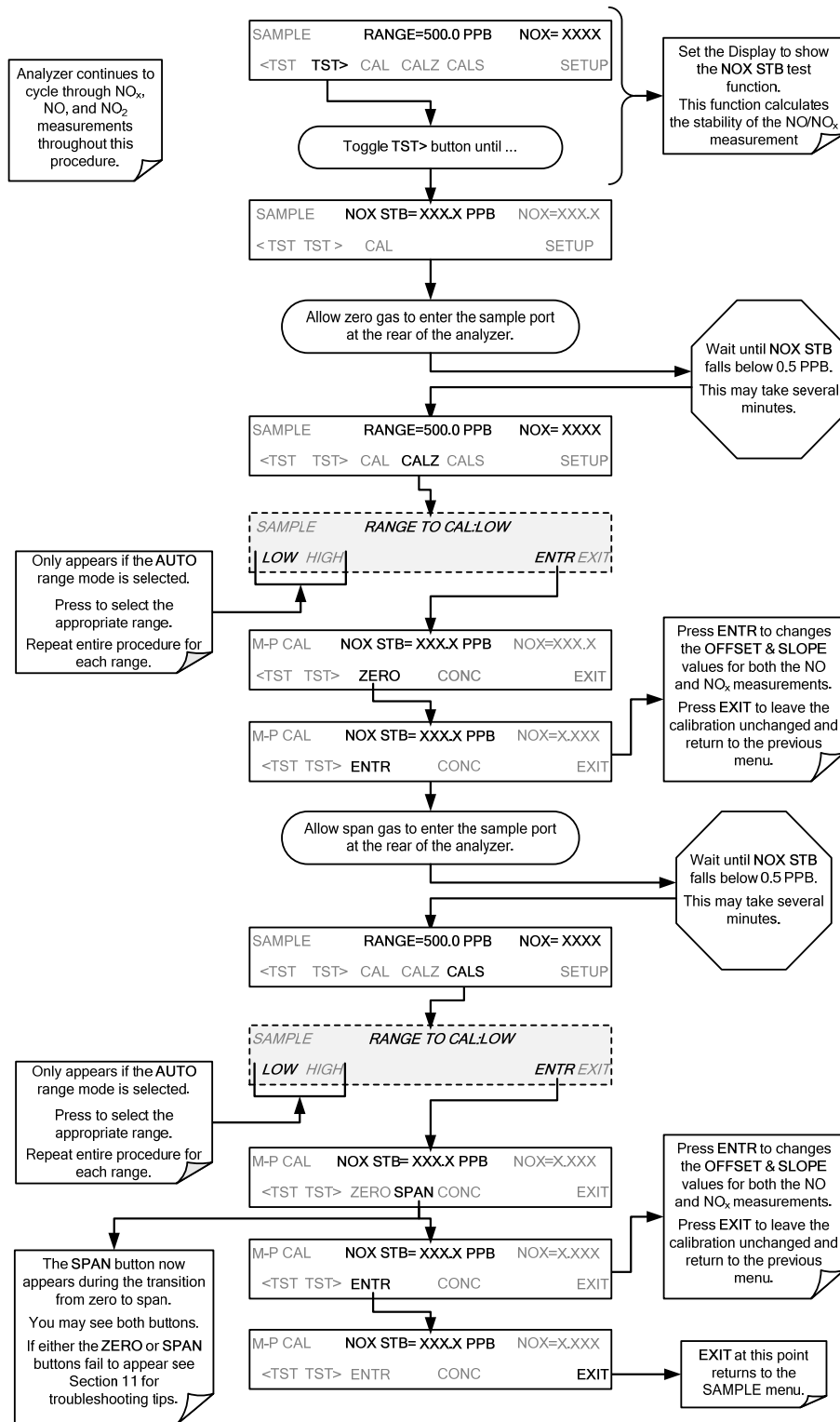

Note

If the ZERO or SPAN buttons are not displayed, the measurement made during is out of the allowable range allowed for a reliable calibration. See Section 12 for troubleshooting tips.

9.4.3.3. Use of Zero/Span Valve with Remote Contact Closure

Contact closures for controlling calibration and calibration checks are located on the rear panel **CONTROL IN** connector. Instructions for setup and use of these contacts are found in Section 3.3.1.6.

When the contacts are closed for at least 5 seconds, the instrument switches into zero, low span or high span mode and the internal zero/span valves will be automatically switched to the appropriate configuration.

- The remote calibration contact closures may be activated in any order.
- It is recommended that contact closures remain closed for at least 10 minutes to establish a reliable reading.
- The instrument will stay in the selected mode for as long as the contacts remain closed.

If contact closures are being used in conjunction with the analyzer's AutoCal (see Section 9.5) feature and the AutoCal attribute "**CALIBRATE**" is enabled, the 9110T will not re-calibrate the analyzer UNTIL when the contact is opened. At this point, the new calibration values will be recorded before the instrument returns to **SAMPLE** mode.

If the AutoCal attribute "**CALIBRATE**" is disabled, the instrument will return to **SAMPLE** mode, leaving the instrument's internal calibration variables unchanged.

9.5. AUTOMATIC ZERO/SPAN CAL/CHECK (AUTOCAL)

The AutoCal system allows unattended periodic operation of the **ZERO/SPAN** valve options by using the 9110T's internal time of day clock. AutoCal operates by executing **SEQUENCES** programmed by the user to initiate the various calibration modes of the analyzer and open and close valves appropriately. It is possible to program and run up to three separate sequences (**SEQ1**, **SEQ2** and **SEQ3**). Each sequence can operate in one of three modes, or be disabled.

Table 9-2: AUTOCAL Modes

MODE NAME	ACTION
DISABLED	Disables the Sequence.
ZERO	Causes the Sequence to perform a Zero calibration/check.
ZERO-SPAN	Causes the Sequence to perform a Zero point calibration/check followed by a Span point calibration/check.
SPAN	Causes the Sequence to perform a Span concentration calibration/check only.

For each mode, there are seven parameters that control operational details of the **SEQUENCE**. They are:

Table 9-3: AutoCal Attribute Setup Parameters

ATTRIBUTE	ACTION
TIMER ENABLED	Turns on the Sequence timer.
STARTING DATE	Sequence will operate after Starting Date.
STARTING TIME	Time of day sequence will run.
DELTA DAYS	Number of days to skip between each Sequence execution. <ul style="list-style-type: none"> • If set to 7, for example, the AutoCal feature will be enabled once every week on the same day.
DELTA TIME	Number of hours later each "Delta Days" Sequence is to be run. <ul style="list-style-type: none"> • If set to 0, the sequence will start at the same time each day. Delta Time is added to Delta Days for the total time between cycles. • This parameter prevents the analyzer from being calibrated at the same daytime of each calibration day and prevents a lack of data for one particular daytime on the days of calibration
DURATION	Number of minutes the sequence operates. <ul style="list-style-type: none"> • This parameter needs to be set such that there is enough time for the concentration signal to stabilize. • The STB parameter shows if the analyzer response is stable at the end of the calibration. • This parameter is logged with calibration values in the DAS.
CALIBRATE	Enable to do a calibration – Disable to do a cal check only. <ul style="list-style-type: none"> • For analyzers with internal span gas generators installed and functioning, when used in US EPA applications, this setting must be set to OFF.
RANGE TO CAL	LOW calibrates the low range, HIGH calibrates the high range. Applies only to auto and remote range modes; this property is not available in single and independent range modes.

IMPORTANT

IMPACT ON READINGS OR DATA

For US EPA controlled/related applications:

For analyzers used in US EPA controlled applications that have internal span gas generators option installed, the CALIBRATE attribute must always be set to OFF

Calibration of instruments used in US EPA related applications should only be performed using external sources of zero air and span gas with an accuracy traceable to EPA or NIST standards and supplied through the analyzer's sample port.

The following example sets sequence #2 to do a zero-span calibration every other day starting at 1:00 AM on September 4, 2011, lasting 15 minutes, without calibration. This will start ½ hour later each iteration.

Table 9-4: Example AutoCal Sequence

MODE AND ATTRIBUTE	VALUE	COMMENT
SEQUENCE	2	Define Sequence #2
MODE	ZERO-SPAN	Select Zero and Span Mode
TIMER ENABLE	ON	Enable the timer
STARTING DATE	Sept. 4, 2011	Start after Sept 4, 2011
STARTING TIME	1:00 AM	First Span starts at 1:00AM
DELTA DAYS	2	Do Sequence #2 every other day
DELTA TIME	00:30	Do Sequence #2 ½ hr later each day
DURATION	15.0	Operate Span valve for 15 min
CALIBRATE	OFF	Calibrate at end of Sequence

IMPORTANT**IMPACT ON READINGS OR DATA**

- The programmed **STARTING_TIME** must be a minimum of 5 minutes later than the real time clock for setting real time clock (See Section 5.6).
- Avoid setting two or more sequences at the same time of the day.
- Any new sequence that is initiated whether from a timer, the **COMM** ports or the contact closure inputs will override any sequence that is in progress.
- The **CALIBRATE** attribute must always be set to **OFF** on analyzers with **IZS** Options installed and functioning.
- Calibrations should **ONLY** be performed using external sources of Zero Air and Span Gas whose accuracy is traceable to EPA standards.

9.5.1. SETUP → ACAL: PROGRAMMING AND AUTO CAL SEQUENCE

To program the example sequence shown in Table 9-4, press:

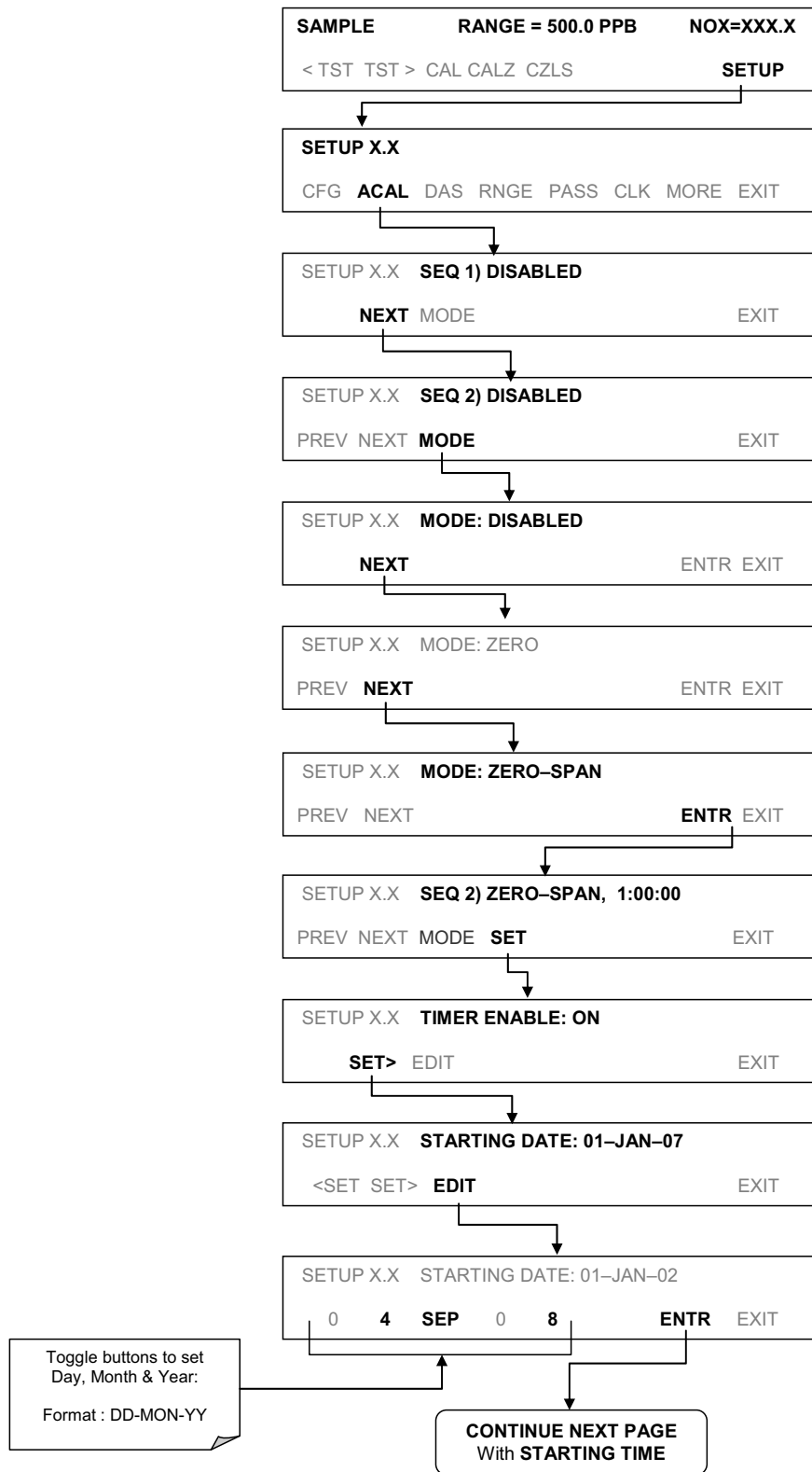

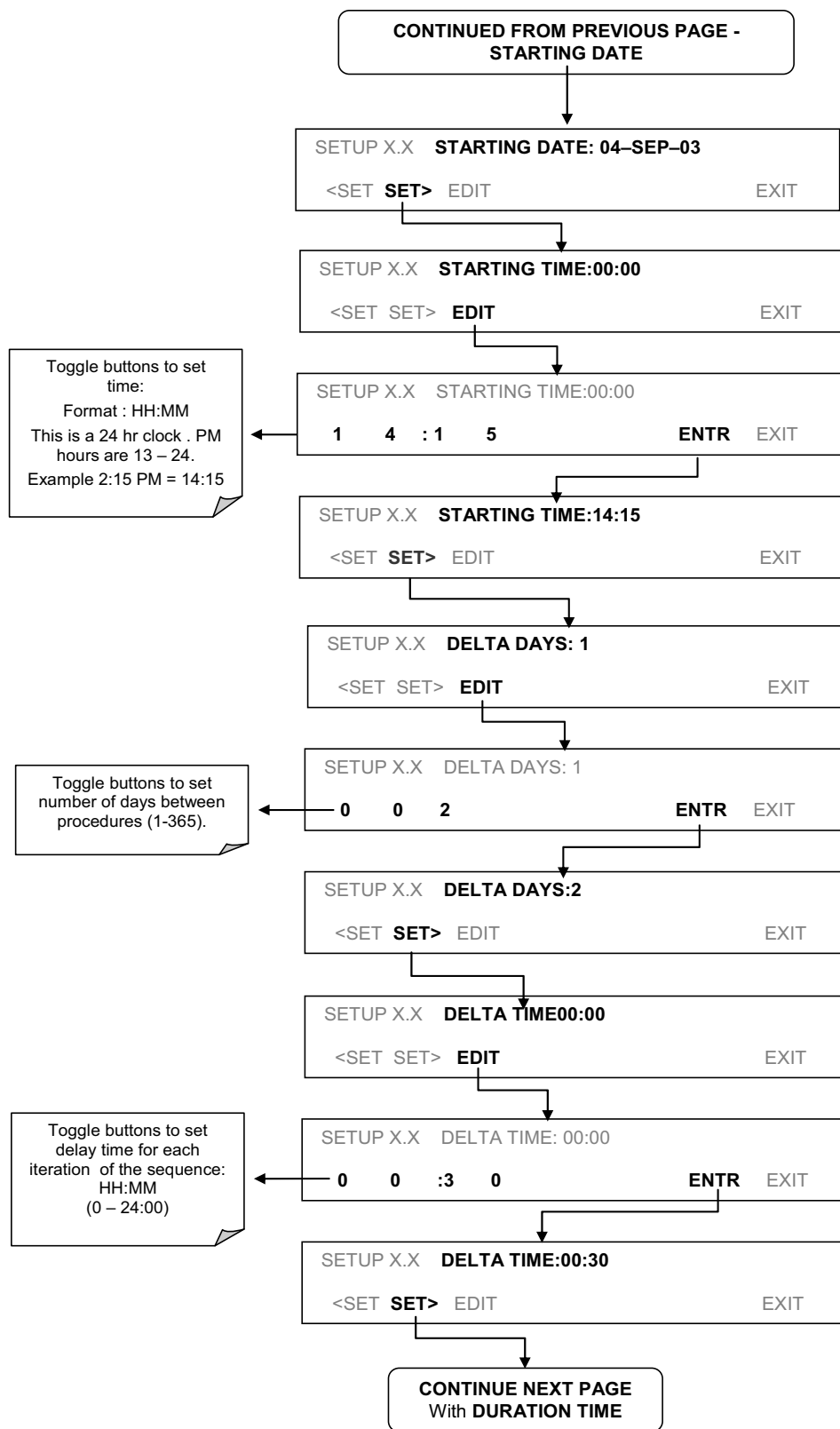

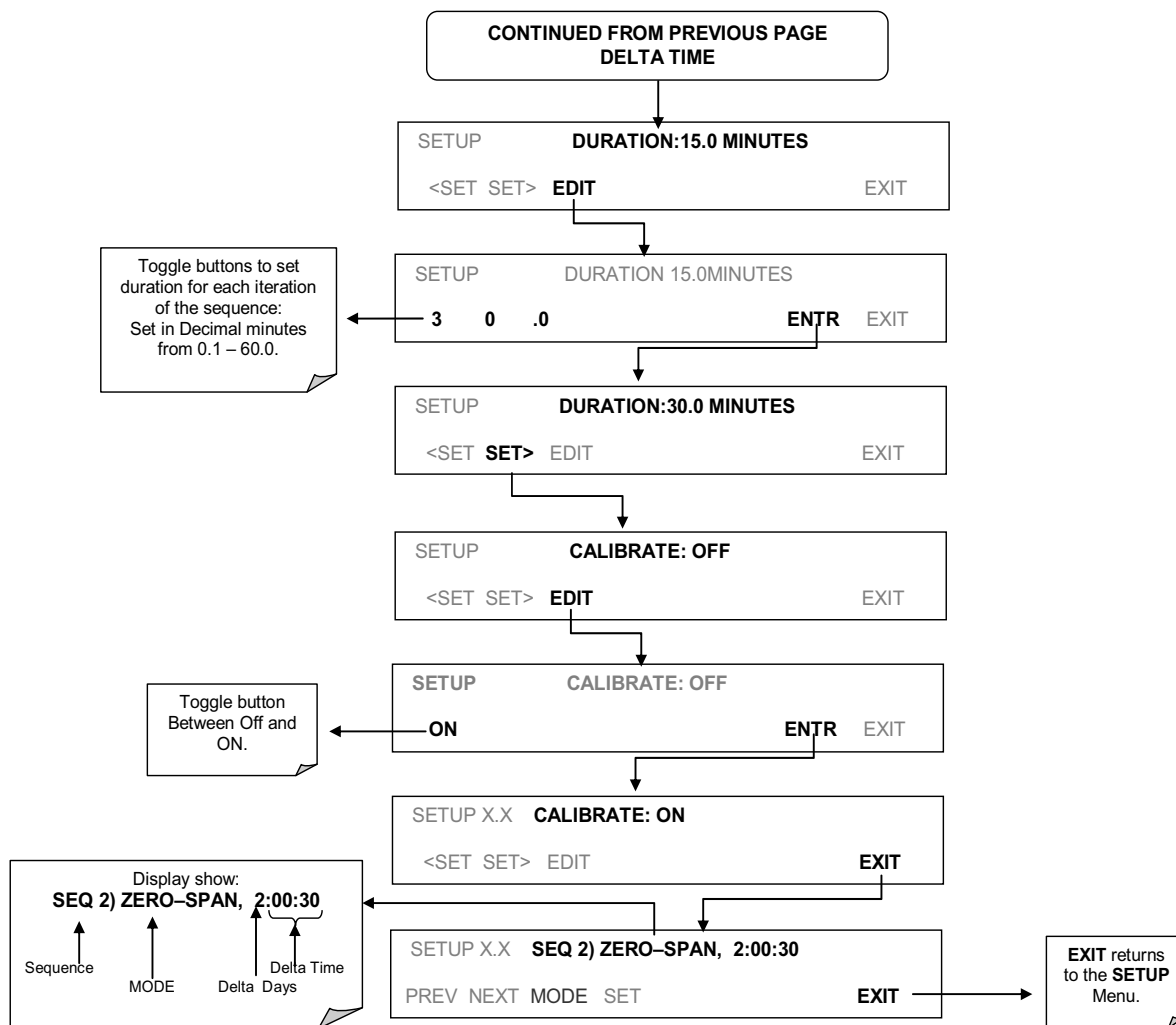

Note

If at any time an unallowable entry is selected (Example: Delta Days > 367) the ENTR button will disappear from the display.

9.6. CALIBRATION QUALITY ANALYSIS

After completing one of the calibration procedures described above, it is important to evaluate the analyzer's calibration **SLOPE** and **OFFSET** parameters. These values describe the linear response curve of the analyzer, separately for NO and NO_x. The values for these terms, both individually and relative to each other, indicate the quality of the calibration.

To perform this quality evaluation, you will need to record the values of the following test functions (see Section 4.1.1), all of which are automatically stored in the DAS channel **CALDAT** for data analysis, documentation and archival.

NO OFFS

NO SLOPE

NOX OFFS

NOX SLOPE

Ensure that these parameters are within the limits listed in Table 9-5 and frequently compare them to those values on the *Final Test and Validation Data Sheet (P/N 04490)* that came attached to your manual, which should not be significantly different. If they are, refer to the troubleshooting Section 12.

Table 9-5: Calibration Data Quality Evaluation

Function	Minimum Value	Optimum Value	Maximum Value
NOX SLOPE	-0.700	1.000	1.300
NO SLOPE	-0.700	1.000	1.300
NOX OFFS	-20.0 mV	0.0 mV	150.0 mV
NO OFFS	-20.0 mV	0.0 mV	150.0 mV

The default DAS configuration records all calibration values in channel CALDAT as well as all calibration check (zero and span) values in its internal memory.

- Up to 200 data points are stored for up 4 years of data (on weekly calibration checks) and a lifetime history of monthly calibrations.
- Review these data to see if the zero and span responses change over time.
- These channels also store the STB figure (standard deviation of NO_x concentration) to evaluate if the analyzer response has properly leveled off during the calibration procedure.
- Finally, the CALDAT channel also stores the converter efficiency for review and documentation.

9.7. GAS FLOW CALIBRATION

Rate of sample gas and O₃ flow through the 9110T is a key part of the NO_x, NO and NO₂ concentration calculations. The **FLOW CALIBRATION** submenu located under the DIAG menu allows the calibration/ adjustment of these calculations.

Note

A separate flow meter is required for this procedure.

To calibrate the flow of gas calculations made by the CPU, press.

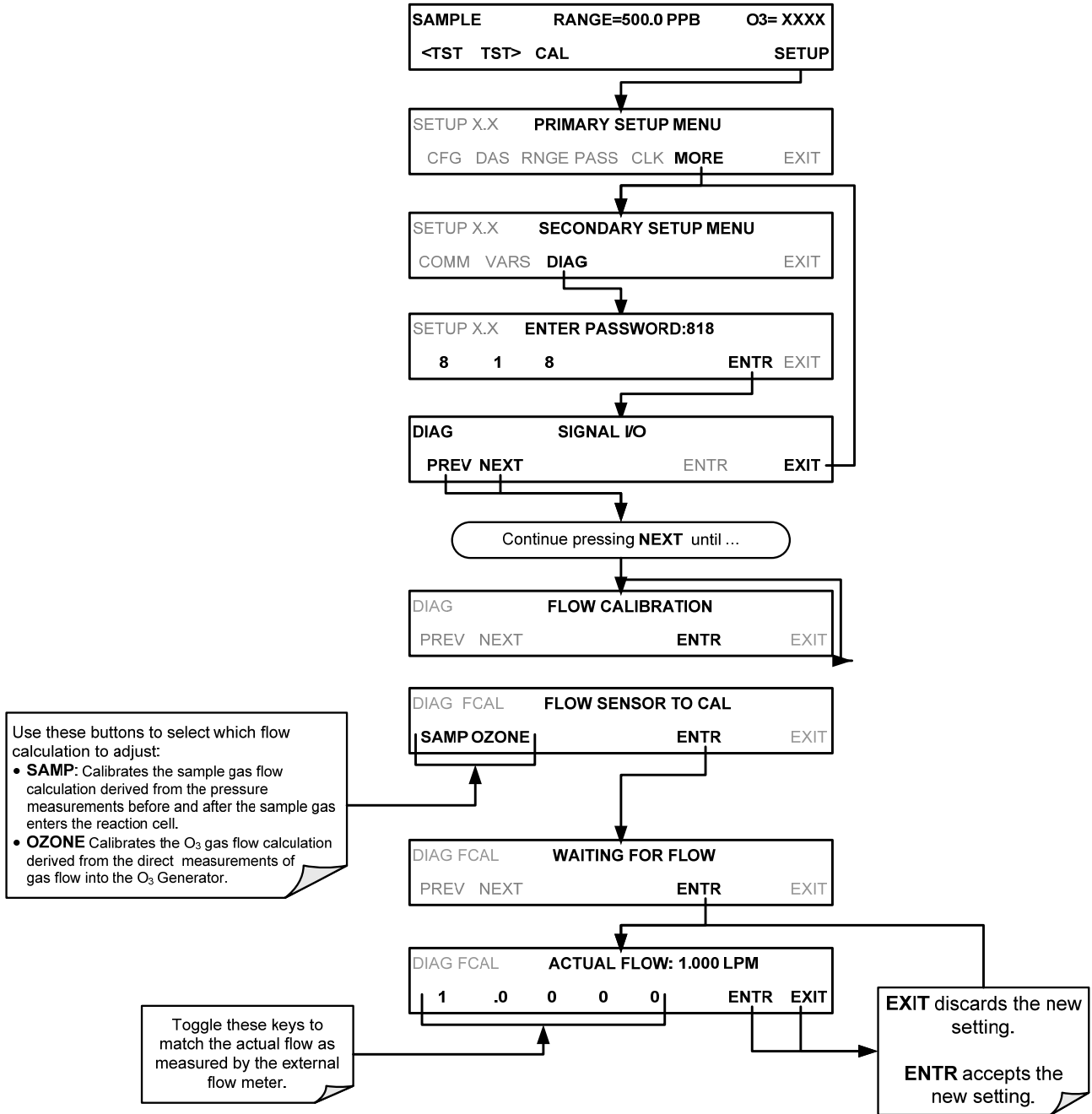

∴

10. EPA PROTOCOL CALIBRATION

To ensure high quality, accurate measurements at all times, the 9110T analyzer must be calibrated prior to use. A quality assurance program centered on this aspect and including attention to the built-in warning features of the analyzer, periodic inspection, regular zero/span checks, regular evaluation of test parameters for predictive diagnostics and data analysis and routine maintenance of the instrument are paramount to achieving this goal.

The US EPA strongly recommends that you obtain a copy of the publication Quality Assurance Handbook for Air Pollution Measurement Systems (abbreviated, Q.A. Handbook Volume II); USEPA Order Number: EPA454R98004; or NIST Order Number: PB99-129876.

This manual can be purchased from:

- EPA Technology Transfer Network (<http://www.epa.gov/ttn/amtic>)
- National Technical Information Service (NTIS, <http://www.ntis.gov/>)

Special attention should be paid to Section 2.3 of the handbook⁸ which covers the measurement of NO₂. Specific regulations regarding the use and operation of ambient NO_x analyzers can be found in Reference 1 at the end of this Section.

If the 9110T is used for EPA compliance monitoring, it must be calibrated in accordance with the instructions in this section.

A bibliography and references relating to NO₂ monitoring are listed in Section 10.10.

10.1. 9110T CALIBRATION – GENERAL GUIDELINES

In general, calibration is the process of adjusting the gain and offset of the 9110T against a standard with certified, traceable concentration. The reliability of data derived from the analyzer depends primarily upon its state of calibration.

In this section, the term *dynamic calibration* is used to express a multipoint check against known standards and involves introducing gas samples of known concentration into the instrument in order to adjust the instrument to a predetermined sensitivity and to produce a calibration relationship. This relationship is derived from the instrumental response to successive samples of different known concentrations. As a minimum, three reference points and a zero point are recommended to define this relationship. The instrument(s) supplying the zero air and Span calibration gases used must themselves be calibrated and that calibration must be traceable to an EPA/ NIST primary standard (see Section 2.0.7 of the Q.A. Handbook and Table 3-8 of this instruction manual)

All monitoring systems are subject to some drift and variation in internal parameters and cannot be expected to maintain accurate calibration over long periods of time. Therefore, it is necessary to dynamically check the calibration relationship on a predetermined schedule. Zero and span checks must be used to document that the data remain within control limits. These checks are also used in data reduction and validation. The internal data acquisition system of the 9110T allows to store all calibration checks (as well as full calibrations) over long periods of time for documentation.

- Table 10-1 summarizes the initial quality assurance activities for calibrating equipment.
- Table 10-2 contains a matrix for the actual, dynamic calibration procedure.

Calibrations should be carried out at the field monitoring site. The analyzer should be in operation for at least several hours (preferably overnight) before calibration so that it is fully warmed up and its operation has stabilized. During the calibration, the 9110T:

- Should be in the **CAL** mode,
- The test atmosphere should be supplied through all components used during normal ambient sampling and through as much of the ambient air inlet system as is practicable.
- If the instrument will be used on more than one range, it should be calibrated separately on each applicable range.
- Details of documentation, forms and procedures should be maintained with each analyzer and also in a central backup file as described in Section 12 of the Quality Assurance Handbook.
- Personnel, equipment and reference materials used in conducting audits must be independent from those normally used in calibrations and operations.

10.2. CALIBRATION EQUIPMENT, SUPPLIES, AND EXPENDABLES

The measurement of NO_x, NO and NO₂ in ambient air requires a certain amount of basic sampling equipment and supplemental supplies. These include, but are not limited to, the following:

Table 10-1: Activity Matrix for EPA Calibration Equipment and Supplies

Equipment/Supplies	Acceptance Limits	Frequency And Method of Measurement	Action If Requirements Are Not Met
Recorder	Compatible with output signal of analyzer; min chart width of 150 mm (6 in) is recommended	Check upon receipt	Return equipment to supplier
Sample line and manifold	Constructed of PTFE, glass or stainless steel	Check upon receipt	Return equipment to supplier
Calibration equipment	Meets guidelines and Section 2.3.2 of Q. A. Handbook	See Section 2.3.9 of Q. A. Handbook	Return equipment/ supplies to supplier or take corrective action
Working standard NO cylinder gas	Traceable to NIST-SRM SRM. Meets limits in traceability protocol for accuracy and stability. Section 2.0.7 of Q. A. Handbook	Analyzed against NIST-SRM; see protocol in Section 2.0.7, Q.A. Handbook	Obtain new working standard and check for traceability
Recording forms	Develop standard forms	N/A	Revise forms as appropriate
Audit equipment	Cannot be the same as used for calibration	System must be checked out against known standards	Locate problem and correct or return to supplier

When purchasing these materials, a logbook should be maintained as a reference for future procurement needs and as a basis for future fiscal planning.

10.2.1. SPARE PARTS AND EXPENDABLE SUPPLIES

In addition to the basic equipment described in the Q.A. Handbook, it is necessary to maintain an inventory of spare parts and expendable supplies. Section 11 describes the parts that require periodic replacement and the frequency of replacement. Appendix B contains a list of spare parts and kits of expendables supplies.

10.2.2. CALIBRATION GAS AND ZERO AIR SOURCES

10.2.2.1. Zero Air

Devices that condition ambient air by drying and removal of pollutants are available on the commercial market such as the Teledyne M701 zero air generator.

10.2.2.2. Span Gas

NO and NO_x calibration gases supplied either directly from pressurized bottles of calibrated gas of different concentrations (see Table 3-8 or from a single source of high concentration gas then mixed to create various lower concentrations. In the latter case, we recommend using a gas dilution calibrator such as a Teledyne M700E.

In ALL cases, the gases and instrument(s) used must be calibrated and that calibration must be traceable to an EPA/NIST primary standard.

10.2.3. DATA RECORDING DEVICE

Either a strip chart recorder, data acquisition system, digital data acquisition system should be used to record the data from the 9110T RS-232 port or analog outputs. If analog readings are being used, the response of that system should be checked against a NIST referenced voltage source or meter. Data recording device should be capable of bi-polar operation so that negative readings can be recorded. Strip chart recorder should be at least 6" (15 cm) wide.

10.2.4. RECORD KEEPING

Record keeping is a critical part of all quality assurance programs. Standard forms similar to those that appear in this manual should be developed for individual programs. Three things to consider in the development of record forms are:

- Does the form serve a necessary function?
- Is the documentation complete?
- Will the forms be filed in such a manner that they can easily be retrieved when needed?

10.3. CALIBRATION FREQUENCY

A system of Level 1 and Level 2 zero/span checks is recommended (see Section 10.4). Level 1 zero and span checks should be conducted at least every two weeks. Level 2 checks should be conducted in between the Level 1 checks at a frequency determined by the user. Span concentrations for both levels should be between 70 and 90% of the reporting range.

To ensure accurate measurements of the NO, NO_x, and NO₂ concentrations, calibrate the analyzer at the time of installation, and recalibrate it:

- No later than three months after the most recent calibration or performance audit that indicated the analyzer calibration to be acceptable.
- An interruption of more than a few days in analyzer operation.

- Any repairs which might affect its calibration.
- Physical relocation of the analyzer.
- Any other indication (including excessive zero or span drift) of possible significant inaccuracy of the analyzer.

Following any of the activities listed above, the zero and span should be checked to determine if a calibration is necessary. If the analyzer zero and span drifts exceed the calibration limits in Section 12 of the Q.A. Handbook⁶, a calibration should be performed.

10.4. LEVEL 1 CALIBRATIONS VERSUS LEVEL 2 CHECKS

All monitoring instruments are subject to some drift and variation in internal parameters and cannot be expected to maintain accurate calibration over long periods of time the EPA requires a schedule of periodic checks of the analyzer’s calibration be implemented. Zero and span checks must be used to document that the data remains within required limits. These checks are also used in data reduction and system validation.

A Level 1 Span check is used to document that the 9110T is within control limits and must be conducted every 2 weeks. A Level 2 Span Check is to be conducted between the Level 1 Checks on a schedule to be determined by the user.

Table 10-2: Definition of Level 1 and Level 2 Zero and Span Checks

LEVEL 1 ZERO AND SPAN CALIBRATION	LEVEL 2 ZERO AND SPAN CHECK
<p>A Level 1 zero and span calibration is a simplified, two-point analyzer calibration used when analyzer linearity does not need to be checked or verified. (Sometimes when no adjustments are made to the analyzer, the Level 1 calibration may be called a zero/span check, in which case it must not be confused with a Level 2 zero/span check.) Since most analyzers have a reliably linear or near-linear output response with concentration, they can be adequately calibrated with only two concentration standards (two-point concentration). Furthermore, one of the standards may be zero concentration, which is relatively easily obtained and need not be certified. Hence, only one certified concentration standard is needed for the two-point (Level 1) zero and span calibration. Although lacking the advantages of the multipoint calibration, the two-point zero and span calibration--because of its simplicity--can be (and should be) carried out much more frequently. Also, two-point calibrations are easily automated. Frequency checks or updating of the calibration relationship with a two-point zero and span calibration improves the quality of the monitoring data by helping to keep the calibration relationship more closely matched to any changes (drifts) in the analyzer response.</p>	<p>A Level 2 zero and span check is an "unofficial" check of an analyzer's response. It may include dynamic checks made with uncertified test concentrations, artificial stimulation of the analyzer's detector, electronic or other types of checks of a portion of the analyzer, etc.</p> <p>Level 2 zero and span checks are not to be used as a basis for analyzer zero or span adjustments, calibration updates, or adjustment of ambient data. They are intended as quick, convenient checks to be used between zero and span calibrations to check for possible analyzer malfunction or calibration drift. Whenever a Level 2 zero or span check indicates a possible calibration problem, a Level 1 zero and span (or multipoint) calibration should be carried out before any corrective action is taken.</p> <p>If a Level 2 zero and span check is to be used in the quality control program, a "reference response" for the check should be obtained immediately following a zero and span (or multipoint) calibration while the analyzer's calibration is accurately known. Subsequent Level 2 check responses should then be compared to the most recent reference response to determine if a change in response has occurred. For automatic Level 2 zero and span checks, the first scheduled check following the calibration should be used for the reference response. It should be kept in mind that any Level 2 check that involves only part of the analyzer's system cannot provide information about the portions of the system not checked and therefore cannot be used as a verification of the overall analyzer calibration.</p>

In addition, an independent precision check between 0.08 and 0.10 ppm must be carried out at least once every two weeks. Table 10-1 summarizes the quality assurance activities for routine operations. A discussion of each activity appears in the following sections.

To provide for documentation and accountability of activities, a checklist should be compiled and then filled out by the field operator as each activity is completed.

For information on shelter and sample inlet system, an in-depth study is in Field Operations Guide for Automatic Air Monitoring Equipment, Publication No. APTD-0736, PB 202-249 and PB 204-650, U.S. Environmental Protection Agency, Office of Air Programs, October 1972

10.5. GAS PHASE TITRATION (GPT)

10.5.1. GPT PRINCIPLE OF OPERATION

Gas phase titration (GPT) is recommended during calibration of the 9110T. Those using a NO₂ permeation tube should refer to the CFR¹.

The principle of GPT is based on the rapid gas phase reaction between NO and O₃ that produces stoichiometric quantities of NO₂ as shown by the following equation:

Equation 10-1

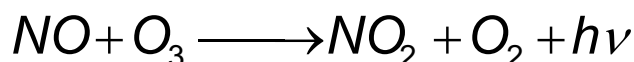

- Given that the O₃ concentration is known for this reaction, the resultant concentration of NO₂ can be determined. Ozone is added to excess NO in a dynamic calibration system as shown in Figure 10-1, and the NO channel of the chemiluminescence analyzer detects the changes in NO concentration.
- After the addition of O₃, the observed decrease in NO concentration on the calibrated NO channel is equivalent to the concentration of NO₂ produced.
- The amount of generated NO₂ may be varied by adding varying amounts of O₃ from a stable O₃ generator.
- All zero air used in this procedure should conform to the requirements stated in Section 10.2 .

Dynamic calibration systems based on this principle are commercially available, or may be assembled by the user. A recommended calibration system is described in the Federal Register CFR¹.

10.5.2. GPT CALIBRATOR CHECK PROCEDURE

It has been empirically determined that the NO-O₃ reaction is complete (<1% residual O₃) if the NO concentration in the reaction cell (ppm) multiplied by the residence time (min.) of the reactants in the chamber is >2.75 ppm min. The theory behind the development of this equation is in the Federal Register¹. The following procedures and equations should be used to determine whether an existing GPT calibration system will meet required conditions for a specific calibration.

For calibrators that have known pre-set flow rates, use equations Equation 10-6 and Equation 10-7 below to verify the required conditions.

If the calibrator does not meet specifications, follow the complete procedure to determine what flow modifications must be made.

1. Select an NO standard gas that has a nominal concentration in the range of 50 to 100 ppm.
 - Determine the exact concentration [NO]STD by referencing against an NIST-SRM SRM, as discussed in the Q.A. Handbook.

2. Determine the volume (cm³) of the calibrator reaction cell (VRC). If the actual volume is not known, estimate the volume by measuring the approximate dimensions of the chamber and using an appropriate formula.
3. Determine the required minimum total flow output (FT) :

Equation 10-2

$$F_T = \text{analyzer flow demand (cm}^3\text{/min)} \times 110/100$$

- If more than one analyzer is to be calibrated at the same time, multiply FT by the number of analyzers.
4. Calculate the NO concentration [NO]_{OUT} needed to approximate 90% of the URL of the NO₂ analyzer to be calibrated:

Equation 10-3

$$[NO]_{OUT} = \text{URL of analyzer (ppm)} \times 90/100$$

5. Calculate the NO flow (F_{NO}) required to generate the NO concentration [NO]_{OUT}:

Equation 10-4

$$F_{NO} = \frac{[NO]_{OUT} \times F_T}{[NO]_{STD}}$$

6. Calculate the required flow through the ozone generator (F_O):

Equation 10-5

$$F_o = \sqrt{\frac{[NO]_{STD} \times F_{NO} \times V_{RC}}{2.75 \text{ ppm} \cdot \text{min}}} - F_{NO}$$

7. Verify that the residence time (t_R) in the reaction cell is <2 min:

Equation 10-6

$$t_R = \frac{V_{RC}}{F_o + F_{NO}} \leq 2 \text{ min}$$

8. Verify that the dynamic parameter specification (P_R) of the calibrator's reaction cell is >2.75 ppm-min:

Equation 10-7

$$P_R = [NO]_{STD} \times \frac{F_{NO}}{F_O + F_{NO}} \times \frac{V_{RC}}{F_O + F_{NO}} \geq 2.75$$

Note

If T_R is >2 minutes or if P_R is <2.75 ppm min, changes in flow conditions (FT, FO, FNO) or in the reaction cell volume (VRC), or both will have to be made, and T_R and P_R will have to be recalculated.

9. After Equation 10-5 and Equation 10-6 are satisfied, calculate the diluent air flow (F_D):

Equation 10-8

$$F_D = F_T - F_O - F_{NO}$$

10.5.2.1. Example GPT Calculation

The following is an example calculation that can be used to determine whether an existing GPT calibrator will meet the required conditions for a specific calibration. For this example, it is assumed that only the volume of the reaction cell, V_{RC} , and the concentration of the NO standard, $[NO]_{STD}$, are known. All flow settings (F_{NO} , F_O , F_T , and F_D) will be calculated. In many uses, these flow settings are known and need only to be substituted in Equations 8-5 and 8-6 to verify the required conditions. Before doing any calculations, the URL and flow demand of the analyzer being calibrated must be known. Operating parameters are determined from the operations manual:

- Upper range limit = 0.5 ppm, and
- Flow demand = 500 cm³/min.
- Volume of calibrator reaction cell is determined by physical measurement: VRC = 180 cm³
- The concentration of the NO standard gas to be used is determined by reference against an NIST-SRM SRM (Section 2.0.7, Q.A. Handbook):

$$[NO]_{STD} = 50.5 \text{ ppm}$$

1. Determine the minimum total flow (F_T) required at the output manifold:

$$F_T = 500 \text{ cm}^3/\text{min} (110/100) = 550 \text{ cm}^3/\text{min}$$

Because low flows are difficult to control and measure, it is often advantageous to set a higher total flow than needed. In this example, we will set F_T to 2750 cm³/min.

2. Determine the highest NO concentration, $[NO]_{OUT}$, required at the output manifold,:

$$[NO]_{OUT} = 0.5 \text{ ppm} (90/100) = 0.45 \text{ ppm}$$

3. Calculate the NO flow (F_{NO}) required to generate the NO concentration $[NO]_{OUT}$:

$$F_{NO} = \frac{0.45 \text{ ppm} \times 2750 \text{ cm}^3 / \text{min}}{50.5 \text{ ppm}} = 24.5 \text{ cm}^3 / \text{min}$$

4. Calculate the required flow rate through ozone generator (F_O):

$$F_O = \sqrt{\frac{50.5 \text{ ppm} \times 24.5 \text{ cm}^3 / \text{min} \times 180 \text{ cm}^3}{2.75 \text{ ppm} \cdot \text{min}}} - 24.5 \text{ cm}^3 / \text{min}$$

$$= \sqrt{80984 \text{ cm}^6 / \text{min}^2} - 24.5 \text{ cm}^3 / \text{min} = 260 \text{ cm}^3 / \text{min}$$

5. Verify that the residence time (t_R) in the reaction cell is <2 min:

$$t_R = \frac{180 \text{ cm}^3}{260 \text{ cm}^3 / \text{min} + 24.5 \text{ cm}^3 / \text{min}} = 0.63 \text{ min}$$

6. Verify the dynamic parameter specification (P_R) of the calibrator reaction cell:

$$P_R = 50.5 \text{ ppm} \times \frac{24 \text{ cm}^3 / \text{min}}{260 \text{ cm}^3 / \text{min} + 24.5 \text{ cm}^3 / \text{min}} \times \frac{180 \text{ cm}^3}{260 \text{ cm}^3 / \text{min} + 24.5 \text{ cm}^3 / \text{min}} = 2.75 \text{ ppm} \cdot \text{min}$$

7. Calculate the diluent airflow (F_D) required at the mixing chamber:

$$F_D = 2750 \text{ cm}^3 / \text{min} - 260 \text{ cm}^3 / \text{min} - 24.5 \text{ cm}^3 / \text{min} = 2465.5 \text{ cm}^3 / \text{min}$$

10.6. GPT MULTIPOINT CALIBRATION PROCEDURE

The procedure for calibration of chemiluminescence NO_x analyzers by GPT is specified in the Federal Register.¹ This section applies the general procedure to the specific case of the 9110T.

Calibration must be performed with a calibrator that meets all conditions specified in the Q.A. Handbook.

Note

The user should be sure that all flow meters are calibrated under the conditions of use against a reliable standard.

All volumetric flow rates should be corrected to 25° C (78°F) and 760 mm (29.92 in.) Hg. Calibrations of flow meters are discussed in the QA Handbook, Vol. II, Part 1, Appendix 126.

Gas Phase Titration (GPT) requires the use of the NO channel of the analyzer to determine the amount of NO₂ generated by titration. Therefore it is necessary to calibrate and determine the linearity of the NO channel before proceeding with the NO₂ calibration. It is also necessary to calibrate the NO_x channel. This can be done simultaneously with the NO calibration. During the calibration the 9110T should be operating in its normal sampling mode, and the test atmosphere should pass through all filters, scrubbers, conditioners, and other components used during normal ambient sampling and as much of the ambient air inlet system as is practicable. All operational adjustments to the 9110T should be completed prior to the calibration.

10.6.1. SET UP FOR GPT MULTIPOINT CALIBRATION OF THE 9110T

The following 9110T features must be activated or set before calibration.

- Calibrate the NO₂ → NO converter (see Section 9.1.4).
- Set the reporting ranges for Independent mode (see Section 5.4.3.2).
- Turn ON the automatic temperature/pressure compensation (TPC) feature (see Section 5.8).
- Set the units of measure to ppb (see Section 5.4.3.4).

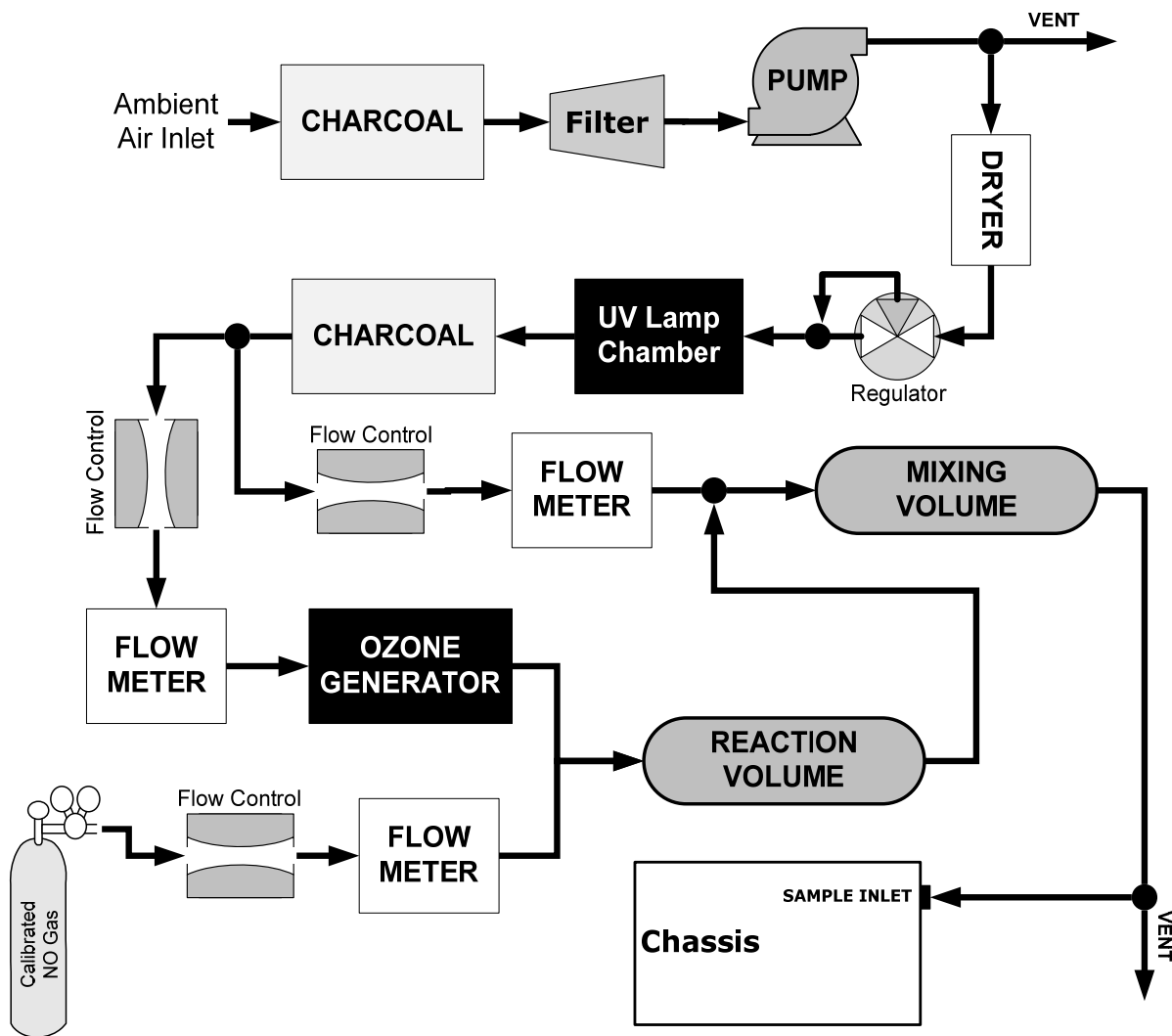

Figure 10-1: GPT Calibration System

IMPORTANT**IMPACT ON READINGS OR DATA**

The analyzer should be calibrated on the same range used for monitoring.

Ensure that the GPT calibration system can supply the range of concentrations at a sufficient flow over the whole range of concentrations that will be encountered during calibration.

10.6.2. ZERO CALIBRATION

The zero point calibration procedure is identical to that described in Sections 9.1, 9.2, 9.4 or 9.5.

10.6.3. SPAN CALIBRATION

1. Adjust the NO concentration to approximately 80% of the URL of the NO channel.
- The expected NO and NOX span concentrations can be determined by measuring the cylinder and diluent flows and computing the resulting concentrations.
- If there is any NO₂ impurity in the NO standard gas it should be taken into account when the NOX concentration is entered during the NO/NOX channel calibration.
- This is done by ADDING the impurity concentration to the NO concentration to get the NOX concentration for calibration. Calculate the exact NO and NOX concentrations as follows:

Equation 10-9

$$[NO]_{OUT} = \frac{F_{NO} \times [NO]_{STD}}{F_T}$$

2. Enter the respective concentrations using the procedure in Section 4.2. The expected span concentrations need not be re-entered each time a calibration is performed unless they are changed.
 3. Enter the expected NOX and NO span gas concentrations:
 4. Sample the generated concentration until the NO and the NOX responses have stabilized.
 5. Span the instrument by the following the same method as 9.1, 9.3 or 9.5.
- The analog voltage output should measure 80% of the voltage range selected. (e.g. 4.00 VDC if 0-5V output is selected.)
 - The readings on the front panel display should be equal to the expected NO and NOX concentrations.

Note

See the Troubleshooting Section 12 if there are problems.

Also see the Calibration Quality Check procedure Section 9.6.

6. After the zero and the 80% upper range limit points have been set, generate five approximately evenly spaced calibration points between zero and 80% upper range limit without further adjustment to the instrument.
7. Allow the instrument to sample these intermediate concentrations for about 10 minutes each and record the instrument NO and NOX responses.
8. Plot the analyzer NO and NOX responses versus the corresponding calculated concentrations to obtain the calibration relationships.
 - Determine the straight line of best fit ($y = mx + b$) determined by the method of least squares.
9. After the best-fit line has been drawn for the NO and the NO_x calibrations, determine whether the analyzer response is linear.
 - To be considered linear, no calibration point should differ from the best-fit line by more than 2% of full scale.

10.7. GPT NO₂ CHECK

The 9110T computes the NO₂ concentration by subtracting the NO from the NO_x concentration. Unlike analog instruments, this difference is calculated by the 9110T's internal computer software. It is extremely unlikely that the NO₂ concentration will be in error. Therefore this procedure is a confirmation that the NO₂ subtraction algorithm in the computer is operating correctly.

IMPORTANT

IMPACT ON READINGS OR DATA

Do not make any adjustments to the instrument during this procedure.

1. Generate an NO concentration near 90% of the upper range limit.
 - Dilution air and O₃ generator air flows should be the same as used in the calculation of specified conditions of the dynamic parameter according to Section 10.5.
2. Sample this NO concentration until the NO and NOx responses stabilize. Record the NO and NOx concentrations.
3. Turn **ON** and adjust the O₃ generator in the calibrator to produce sufficient O₃ to decrease the NO concentration to about 10% of full scale.
 - This will be equivalent to 80% of the URL of the NO₂ channel. After the analyzer responses stabilize, record the resultant NO, NOX, and NO₂ concentrations.

Note

If the NO_x reading should drop to less than 96% of its starting value during this step, it indicates the NO₂ converter is in need of troubleshooting or replacement. See Section 12.7.10 for further details.

4. While maintaining all other conditions, adjust the ozone generator to obtain several other concentrations of NO₂ evenly spaced between the 80% URL point and the zero point. Record the NO, NO_x, and NO₂ concentrations for each additional point.
5. Calculate the resulting NO₂ concentrations as follows:

Equation 10-10

$$[NO_2]_{OUT} = [NO]_{ORIG} - [NO]_{REM} + \frac{F_{NO} * [NO_2]_{IMP}}{F_T}$$

Where [NO]_{ORIG} is the NO concentration before the GPT ozone is turned on, and [NO]_{REM} is the NO remaining after GPT.

Plot the NO₂ concentration output by the instrument on the y-axis against the generated NO₂ [NO₂]_{OUT} on the x-axis. The plot should be a straight line within the ± 2% linearity criteria given for the NO_x and NO channels. If the plot is not linear, the most likely cause is that the converter needs replacing. See Section 9.1.4 on NO₂ converter efficiency and Section 11.3.8 for changing the converter if needed.

10.8. OTHER QUALITY ASSURANCE PROCEDURES

Precision is determined by a one-point check at least once every two weeks. Accuracy is determined by a three-point audit once each quarter.

Essential to quality assurance are scheduled checks for verifying the operational status of the monitoring system. The operator should visit the site at least once each week. Every two weeks a Level 1 zero and span check must be made on the analyzer. Level 2 zero and span checks should be conducted at a frequency desired by the user. Definitions of these terms are given in Table 10-2.

10.8.1. SUMMARY OF QUALITY ASSURANCE CHECKS

The following items should be checked on a regularly scheduled basis to assure high quality data from the 9110T. See Table 10-3 for a summary of activities; also the QA Handbook should be checked for specific procedures.

Table 10-3: Activity Matrix for Data Quality

Characteristic	Acceptance Limits	Frequency and Method of Measurement	Action if Requirements are not Met
Shelter temperature	Mean temperature between 22°C and 28°C (72° and 82° F), daily fluctuations not greater than $\pm 2^\circ\text{C}$	Check thermograph chart weekly for variations greater than $\pm 2^\circ\text{C}$ (4°F)	Mark strip chart for the affected time period. Repair or adjust temperature control.
Sample introduction system	No moisture, foreign material, leaks, obstructions; sample line connected to manifold	Weekly visual inspection	Clean, repair, or replace as needed.
Recorder	Adequate ink & paper Legible ink traces Correct chart speed and range Correct time	Weekly visual inspection	Replenish ink and paper supply. Adjust time to agree with clock; note on chart.
Analyzer operational settings	TEST measurements at nominal values 9110T in SAMPLE mode	Weekly visual inspection	Adjust or repair as needed.
Analyzer operational check	Zero and span within tolerance limits as described in Section 12 of the Q.A. Handbook ⁶	Level 1 zero/span every 2 weeks; Level 2 between Level 1 checks at frequency desired by user	Find source of error and repair. After corrective action, re-calibrate analyzer.
Precision check	Assess precision as described in Sections 15&18 of the Q.A. Handbook ⁶	Every 2 weeks, Subsection 3.4.3 (Ibid.)	Calc, report precision, Section 12 of the Q.A. Handbook ⁶ .

10.8.2. SHORT CALIBRATION CHECKS

A system of Level 1 and Level 2 zero/span checks (Table 10-2) is recommended. These checks must be conducted in accordance with the specific guidance given in Section 12 of the Q.A. Handbook⁶. Level 1 zero and span checks must be conducted every two weeks. Level 2 checks should be conducted in between the Level 1 checks at a frequency desired by the user. Span concentrations for both levels should be between 70 and 90% of the measurement range.

Zero and span data are to be used to:

- Provide data to allow analyzer adjustment for zero and span drift;
- Provide a decision point on when to calibrate the analyzer;
- Provide a decision point on invalidation of monitoring data.

These items are described in detail in Sections 15 & 18 of the Q.A. Handbook⁶. Refer to Section 11 of this manual if the instrument is not within the allowed margins. We recommend using APICOM and the DAS for analysis and documentation of zero/span check data.

10.8.3. ZERO/SPAN CHECK PROCEDURES

The Zero and span calibration can be checked in a variety of different ways. They include:

- Manual zero/span checks can be done from the front panel touchscreen. The procedure is in Section 9.2.2 of this manual.
- Automatic zero/span checks can be performed every night. See Section 9.5 of this manual for setup and operation procedures.

- Zero/Span checks through remote contact closure can be initiated through remote contact closures on the rear panel. See Section 9.4.3.3 of this manual.
- Zero/span checks can also be controlled through the RS-232 port. See Section 8 of this manual for more details on setting up and using the analyzer's RS-232 port.

10.8.4. PRECISION CHECK

A periodic check is used to assess the data for precision. A one-point precision check must be carried out at least once every 2 weeks on each analyzer at an NO₂ concentration between 0.08 and 0.10 ppm.

- The analyzer must be operated in its normal sampling mode, and the precision test gas must pass through all filters, scrubbers, conditioners, and other components used during normal ambient sampling.
- The standards from which precision check test concentrations are obtained must be traceable to NIST-SRM SRM. Those standards used for calibration or auditing may be used.

10.8.4.1. Precision Check Procedure

Connect the analyzer to a precision gas that has an NO₂ concentration between 0.08 and 0.10 ppm. An NO₂ precision gas may be generated by either GPT or a NO₂ permeation tube. If a precision check is made in conjunction with a zero/span check, it must be made prior to any zero or span adjustments.

- Allow the analyzer to sample the precision gas until a stable trace is obtained.
- Record this value.
- NO and NO_x precision checks should also be made if those data are being reported. Information from the check procedure is used to assess the precision of the monitoring data; see in Section 12 of the Q.A. Handbook⁶ for procedures for calculating and reporting precision.

10.9. CERTIFICATION OF WORKING STANDARDS

The NO content of the NO working standard must be periodically assayed against NIST-traceable NO or NO₂ standards. Any NO₂ impurity in the cylinder must also be assayed. Certification of the NO working standard should be made on a quarterly basis or more frequently, as required. Procedures are outlined below for certification against NO traceable standard which is the simplest and most straightforward procedure.

To assure data of desired quality, two considerations are essential:

- The measurement process must be in statistical control at the time of the measurement and;
- Any systematic errors, when combined with the random variation in the measurement process, must result in a suitably small uncertainty.

Evidence of good quality data includes documentation of the quality control checks and the independent audits of the measurement process by recording data on specific forms or on a quality control chart and by using materials, instruments, and measurement procedures that can be traced to appropriate standards of reference.

To establish traceability, data must be obtained routinely by repeated measurements of standard reference samples (primary, secondary, and/or working standards). More specifically, working calibration standards must be traceable to standards of higher accuracy.

10.9.1.1. Certification Procedures of Working Standards

This procedure requires the use of calibrated NO gas traceable to an NIST-SRM SRM and the gas phase titration calibration procedure (Section 10.5) to calibrate the NO, NO_x, and NO₂ responses of the analyzer. Also the efficiency of the analyzer's NO₂ converter must be determined (Section 9.1.4).

Generate several NO concentrations by diluting the NO working standard. Use the nominal NO cylinder concentration, [NO]_{NOM}, to calculate the diluted concentrations. Plot the analyzer NO response (in ppm) versus the nominal diluted NO concentration and determine the slope, S_{NOM}. Calculate the NO concentration of the working standard [NO]_{STD} from:

Equation 10-11

$$[NO]_{STD} = [NO]_{NOM} \times S_{NOM}$$

A more detailed procedure is presented in Reference 1 (Section 10.10).

10.9.1.2. Other Methods of Establishing Traceability

Methods of establishing traceability are:

- Using a NO working standard traced to NIST NO₂ standard.
- Using a NO₂ working standard traced to NIST NO₂ standard.
- Using a NO₂ working standard traced to NIST NO standard.

IMPORTANT

IMPACT ON READINGS OR DATA

If the NO₂ impurity in the NO cylinder, [NO₂]_{imp} is greater than the 1 ppm value allowed in the calibration procedure, check that the NO delivery system is not the source of contamination before discarding the NO standard.

For further information on calibration by GPT and NO₂ permeation devices, refer to part 50 of Section 1, Title 40 CFR, Appendix F Reference 13 of that Appendix.

10.10. REFERENCES

1. Environmental Protection Agency, Title 40, Code of Federal Regulations, Part 50, Appendix F, Measurement Principle and Calibration Procedure for the Measurement of Nitrogen Dioxide in the Atmosphere (Gas Phase Chemiluminescence), Federal Register, 41 (232), 52688-52692, December 1976 (as amended at 48 FR 2529, Jan 20, 1983).
2. Ellis, Elizabeth C. Technical Assistance Document for the Chemiluminescence Measurement of Nitrogen Dioxide, U.S. Environmental Protection Agency, Research Triangle Park, NC. 83 pages, December 1975. Available online at <http://www.epa.gov/ttn/amtic/files/ambient/criteria/reldocs/4-75-003.pdf>.
3. Environmental Protection Agency, Title 40, Code of Federal Regulations, Part 58, Appendix A, Measurement Principle and Calibration Procedure for the Measurement of Nitrogen Dioxide in the

Atmosphere (Gas Phase Chemiluminescence), Federal Register, 41 (232), 52688-52692, December 1976 (as amended at 48 FR 2529, Jan 20, 1983).

4. Mavrodineanu, R., and Gills, T. E., Standard Reference Materials: Summary of Gas Cylinder and Permeation Tube Standard Reference Materials Issued by the National Bureau of Standards, Document SP260-108, May 1987.
And: Taylor, J. K., Standard Reference Materials: Handbook for SRM Users, Document number SP260-100, February 1993. Available online at:
http://patapsco.nist.gov/srmcatalog/sp_publications/publications.htm
5. Quality Assurance Handbook for Air Pollution Measurement Systems - Volume I, "A Field Guide to Environmental Quality Assurance." EPA-600/R-94/038a, April 1994. Available online at:
<http://www.epa.gov/ttn/amtic/qabook.html>.
6. Quality Assurance Handbook for Air Pollution Measurement Systems - Volume II, Ambient Air Specific Methods. EPA-600/4-77/027a, December 1986. US EPA Order Number: 454R98004, available at the National Technical Information Service (NTIS), 5285 Port Royal Rd Springfield, VA 22151. Portions are also available at: <http://www.epa.gov/ttn/amtic/qabook.html>.
7. Environmental Protection Agency, Title 40, Code of Federal Regulations, Part 58, Appendix B, Measurement Principle and Calibration Procedure for the Measurement of Nitrogen Dioxide in the Atmosphere (Gas Phase Chemiluminescence), Federal Register, 41 (232), 52688-52692, December 1976 (as amended at 48 FR 2529, Jan 20, 1983).
8. Quality Assurance Guidance Document. Reference Method for the Determination of Nitrogen Dioxide in the Atmosphere (Chemiluminescence). Draft document, 58 pages, February 2002. Office of Air Quality Planning and Standards, Research Triangle Park NC 27711, draft document available at <http://www.epa.gov/ttn/amtic/qabook.html>. Guidelines about the measurement of NO₂ in this document replace those in the old QA Handbook and should be consulted as the latest reference.

PART III
—
MAINTENANCE AND SERVICE

: This page intentionally left blank.

11. INSTRUMENT MAINTENANCE

For the most part, the 9110T analyzer is maintenance free. However it is recommended that a minimal number of simple procedures be performed regularly to ensure that the 9110T continues to operate accurately and reliably over its lifetime. In general, the exterior can be wiped down with a lightly damp cloth; avoid spraying anything directly onto any part of the analyzer.

Service and troubleshooting are covered in Section Troubleshooting & Service.

11.1. MAINTENANCE SCHEDULE

Table 11-1 shows a typical maintenance schedule for the 9110T. Please note that in certain environments (i.e. dusty, very high ambient pollutant levels) some maintenance procedures may need to be performed more often than shown.

IMPORTANT

IMPACT ON READINGS OR DATA

A span and zero calibration check (see **CAL CHECK REQ'D** Column of Table 11-1, 9110T Maintenance Schedule) must be performed following some of the maintenance procedures listed herein.

To perform a **CHECK** of the instrument's Zero or Span Calibration, follow the same steps as described in Section 9.3.

DO NOT press the **ENTR** button at the end of each operation. Pressing the **ENTR** button resets the stored values for **OFFSET** and **SLOPE** and alters the instrument's Calibration.

Alternately, use the **Auto Cal** feature described in Section 9.5 with the **CALIBRATE** attribute set to **OFF**.



WARNING – ELECTRICAL SHOCK HAZARD

Disconnect power before performing any of the following operations that require entry into the interior of the analyzer.



CAUTION – QUALIFIED PERSONNEL

These maintenance procedures must be performed by qualified technicians only.

Table 11-1: 9110T Maintenance Schedule

ITEM	ACTION	FREQ	CAL CHECK REQ'D	DATE PERFORMED													
TEST functions	Review and evaluate	Weekly	No														
Particulate filter	Change particulate filter	Weekly	No														
Zero/span check	Evaluate offset and slope	Weekly	No														
Zero/span calibration	Zero and span calibration	Every 3 months	Yes														
External zero air scrubber option	Exchange chemical	Every 3 months	No														
External dryer option	Replace chemical	When indicator color changes	No														
Ozone cleanser	Change chemical	Annually	Yes														
Reaction cell window ("optical filter" in Figure 11-6)	Clean	Annually or as necessary	Yes														
DFU filters	Change particulate filter	Annually	No														
Pneumatic sub-system	Check for leaks in gas flow paths	Annually or after repairs involving pneumatics	Yes if a leak is repaired														
Reaction cell O-rings & sintered filters	Replace	Annually	Yes														
PMT Sensor Hardware Calibration	Low-level hardware calibration	On PMT/ preamp changes or if slope is outside of 1.0±0.3	Yes														
Pump	Rebuild head	when RCEL pressure exceeds 10 in-Hg-A (at sea level)	Yes														
Inline Exhaust Scrubber	Replace	Annually	No														
NO ₂ converter	Replace converter	Every 3 years or if conversion efficiency drops below 96%	Yes														
Desiccant bags	Replace	Any time PMT housing is opened for maintenance	n/a														

11.2. PREDICTIVE DIAGNOSTICS

Predictive diagnostic functions including failure warnings and alarms built into the analyzer's firmware allow the user to determine when repairs are necessary.

The Test Functions can also be used to predict failures by looking at how their values change over time. Initially it may be useful to compare the state of these Test Functions to the values recorded on the printed record of the *Final Test and Validation Data Sheet*, P/N 04490.

The following table can be used as a basis for taking action as these values change with time. The internal data acquisition system (DAS) is a convenient way to record and track these changes. Use APICOM (Section 8.1.1) to download and review this data from a remote location.

Table 11-2: Predictive Uses for Test Functions

FUNCTION	EXPECTED	ACTUAL	INTERPRETATION & ACTION
RCEL (pressure)	Constant to within ± 0.5 in-Hg-A	Fluctuating	Developing leak in pneumatic system. Check for leaks.
		Slowly increasing	Pump performance is degrading. Rebuild pump when pressure is above 10 in-Hg-A.
SAMP (pressure)	Constant within atmospheric changes	Fluctuating	Developing leak in pneumatic system. Check for leaks.
		Slowly increasing	Flow path is clogging up. Replace orifice filters.
		Slowly decreasing	Developing leak in pneumatic system to vacuum (developing valve failure). Check for leaks.
OZONE FL	Constant to within ± 15	Slowly decreasing	Flow path is clogging up. Replace orifice filters.
AZERO	Constant within ± 20 of check-out value	Significantly increasing	Developing AZERO valve failure. Replace valve.
			PMT cooler failure. Check cooler, circuit, and power supplies.
			Developing light leak.
			O ₃ air filter cartridge is exhausted. Change chemical.
NO₂ (Concentration)	Constant for constant concentrations	Slowly decreasing signal for same concentration	Converter efficiency may be degrading. Replace converter components.
NO₂ with IZS Option installed (Concentration)	Constant response from day to day	Decreasing over time	Change in instrument response. Low level (hardware) calibrate the sensor.
		Heavily fluctuating from day to day	Degradation of IZS permeation tube. Change permeation tube. Ambient changes in moisture are affecting the performance. Add a dryer to the zero air inlet.
NO (Concentration)	Constant for constant concentration	Decreasing over time	Drift of instrument response; clean RCEL window. Check for flow leaks or irregularities.

Note

It is recommended that the above functions be checked weekly.

11.3. MAINTENANCE PROCEDURES

The following procedures are to be performed periodically as part of the standard maintenance of the 9110T.

11.3.1. REPLACING THE SAMPLE PARTICULATE FILTER

The particulate filter should be inspected often for signs of plugging or contamination. We recommend that when you change the filter; handle it and the wetted surfaces of the filter housing as little as possible. Do not touch any part of the housing, filter element, PTFE retaining ring, glass cover and the o-ring with your bare hands. Teledyne API recommends using gloves or PTFE coated tweezers or similar handling to avoid contamination of the sample filter assembly.

To change the filter:

1. Turn OFF the analyzer to prevent drawing debris into the instrument.
2. Open the 9110T's hinged front panel and unscrew the retaining ring on the filter assembly.

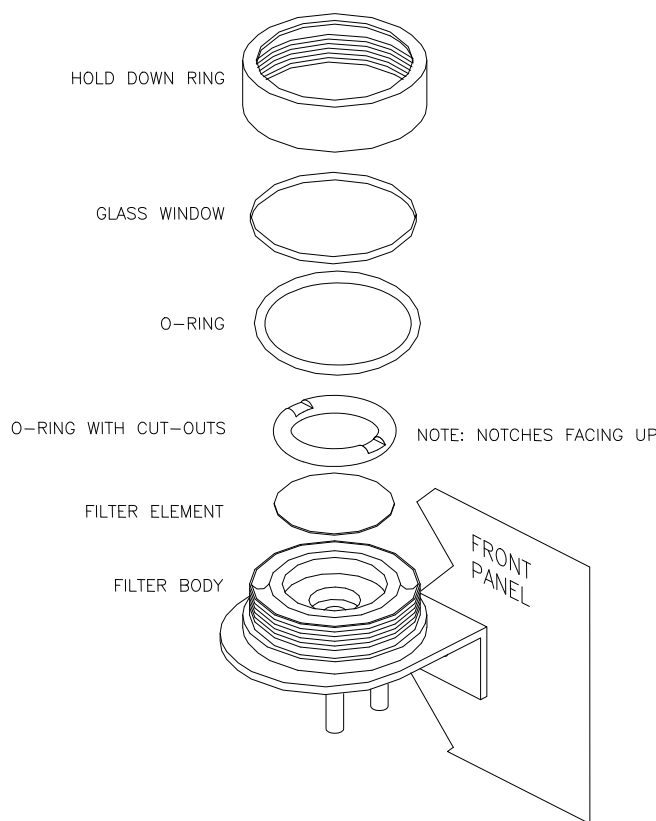

Figure 11-1 Replacing the Particulate Filter

3. Carefully remove the retaining ring, PTFE o-ring, glass filter cover and filter element.
4. Replace the filter, being careful that the element is fully seated and centered in the bottom of the holder.
5. Reinstall the PTFE o-ring with the notches up; the glass cover, then screw on the retaining ring and hand tighten. Inspect the seal between the edge of filter and the o-ring to assure a proper seal.
6. Restart the Analyzer.

11.3.2. CHANGING THE O₃ DRYER PARTICULATE FILTER

The air for the O₃ generator passes through a Perma Pure[®] dryer, which is equipped with a small particulate filter at its inlet. This filter prevents dust from entering the Perma Pure[®] dryer and degrading the dryer's performance over time. Change the filter according to the service interval in Table 11-1 as follows:

1. Before starting the procedure, check and write down the average RCEL pressure and the OZONE FLOW values.
2. Turn off the analyzer, unplug the power cord and remove the cover.
3. Unscrew the nut around the port of the filter using two 5/8" wrenches.

ATTENTION

COULD DAMAGE INSTRUMENT AND VOID WARRANTY
 Ensure to use proper wrenches.

Hold the main dryer fitting with a 5/8" wrench to ensure that it does not turn against the Perma Pure[®] dryer.

Performing this procedure improperly or with incorrect tools creates a risk of causing a significant leak.

4. Take off the old filter element and replace it with a suitable equivalent (TAI P/N FL-3).

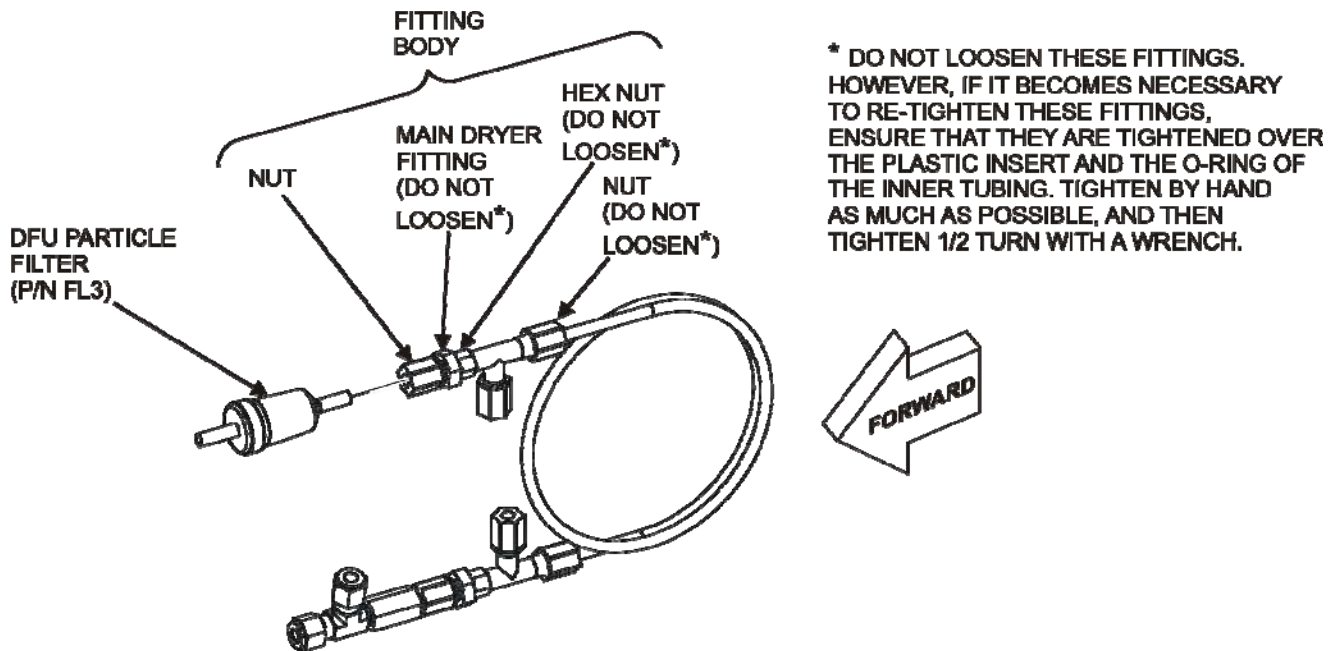

P/N 04543A

Figure 11-2: Particle Filter on O₃ Supply Air Dryer

5. Holding the main dryer fitting steady with a 5/8" wrench and tighten the nut with your hands.
 - If necessary use a second wrench but do not over-tighten the nut.
6. Replace the cover, plug in the power cord and restart the analyzer.
7. Check the O₃ flow rate; it should be around 80 cm³/min ± 15.
8. Check the RCEL pressure.
 - It should be the same value as before.
9. Refer to Section 13.3.12 to leak check after installing the new DFU particle filter.

11.3.3. CHANGING THE OZONE CLEANSER CHEMICAL

The ozone (O₃) cleanser is located next to the O₃ generator (see Figure 3-5) and cleans the O₃ stream from solid and liquid contaminants that are created inside the O₃ generator. The content of the ozone cleanser needs periodical exchange according to Table 11-1. A rebuild kit is available from the factory (see Appendix B of this manual lists the part numbers).

To change the ozone cleanser chemical, follow these steps:

1. Turn off power to the analyzer and pump. Remove the analyzer cover and locate the O₃ filter in the front of the analyzer next to the O₃ generator.
2. Use a 7/16" wrench to remove both pieces of 1/8" male nut with tubing from the NPT fittings.

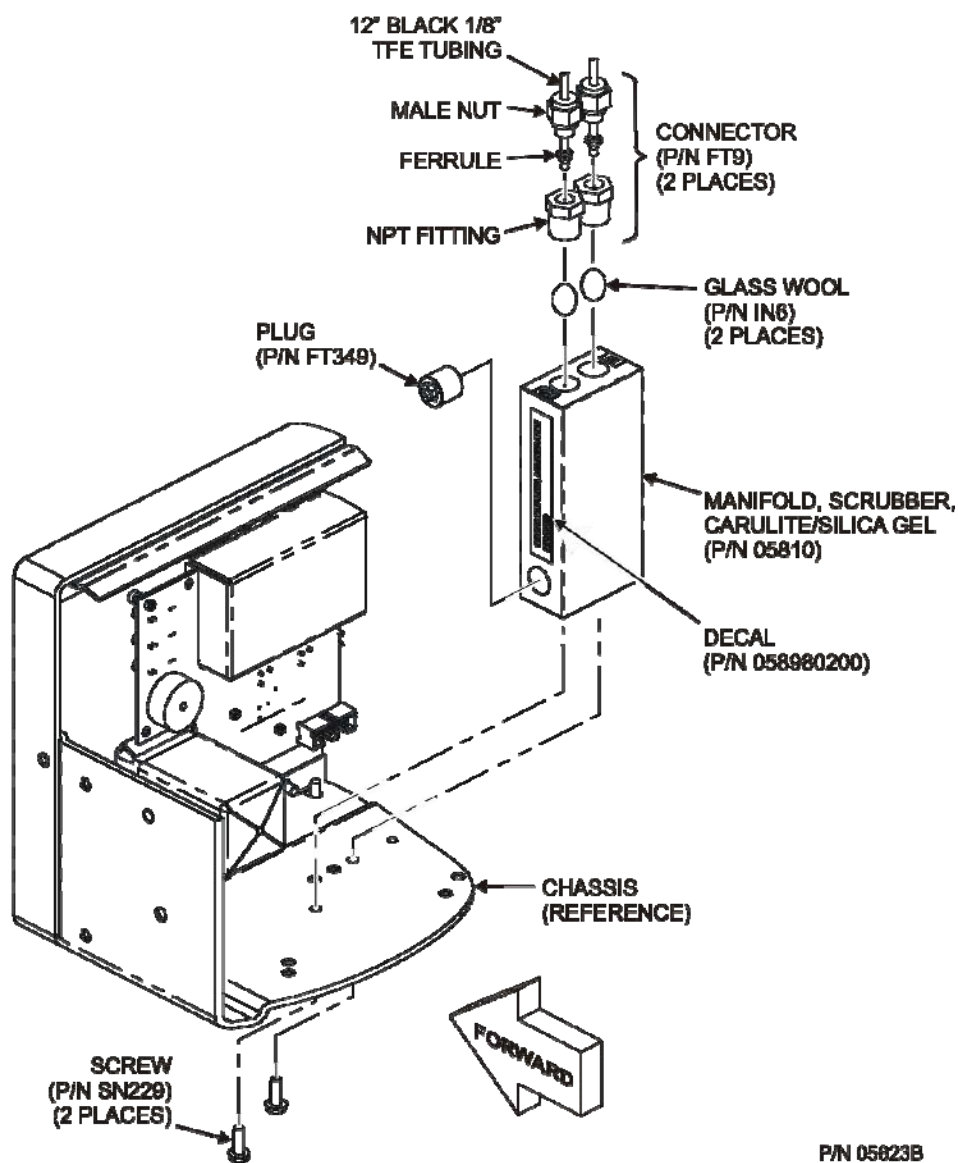

Figure 11-3: Ozone Cleanser Assembly

3. Remove the integrated screws with a Phillips screw driver and remove the scrubber manifold from the chassis.
4. Using a 9/16" wrench, remove both fittings from the cartridge.
5. Discard the glass wool.
6. Pour the contents of the scrubber manifold onto a sheet of white paper. If necessary, remove the plug to ensure that all the contents are poured out.
 - Notice any discoloration of the contents, which is usually white and slightly transparent.
 - The amount of discolored chemical (usually with yellow tint) may give you an indication of the lifetime of the chemical in your application.

The maintenance cycle of this item is dependent on ambient moisture, sub-micron particle load and other factors and may differ from that shown in Table 11-1.

7. Discard the used silica gel desiccant without touching it. It may contain nitric acid, which is a corrosive and highly irritating substance.



CAUTION – GENERAL SAFETY HAZARD

Immediately wash your hands after contact with the silica gel desiccant.

8. Using a small powder funnel, fill the cartridge with about 10 g new silica gel desiccant (TAI P/N CH43) so that it is level on both legs of the cartridge.
 - Slight vibration is required to settle the chemical into the cartridge and achieve tightest packing, which increases performance and lifetime of the filter.
 - Ensure that the level of the chemical does not protrude farther than the first two threads of the NPT fitting.

IMPORTANT

IMPACT ON READINGS OR DATA

Use only genuine, pre-conditioned Teledyne refill kits for this procedure. Teledyne refill kits have been properly conditioned to prevent a significant increase of the 9110T's Auto Zero value which can cause large negative offsets, which may take 2-3 weeks to disappear.

Do not leave this material uncovered for more than a few seconds, as it will absorb contaminants from ambient air. Always store unused, well-covered refill material in a cool dry place.

9. Seal the silica gel desiccant with 1 cm³ of glass wool on each well.
 - Ensure that the plug is large enough and compressed into the cartridge so that the chemical is securely held in place.
10. Add new Teflon tape (P/N HN000036) to the NPT fittings.
11. Screw the NPT fittings back into the scrubber manifold.
12. Screw the cartridge back onto the chassis; orientation is not important.
13. Evaluate the ferrules on the tubing.
 - If the ferrules are too old, we recommend replacing them with new ferrules.
14. Reconnect the tubing using 7/16" and 9/16" wrenches.
 - Do not over-tighten the fittings.
15. If the service interval for this item has been exceeded, it may also be necessary to clean the reaction cell as described in Section 11.3.9.
16. Leak check the system using the pressurized approach described in Section 11.3.12.2.

- If necessary, tighten the fittings some more but do not over-tighten.
17. Restart the analyzer and pump and continue operation.
 18. Recalibrate the analyzer after one hour (Section 9).
- If Auto Zero is high or is changing/not constant, you may have to wait a day until the silica gel is conditioned before recalibrating the instrument.

11.3.4. MAINTAINING THE EXTERNAL SAMPLE PUMP (PUMP PACK)

11.3.4.1. Rebuilding the Pump

The sample pump head periodically wears out and must be replaced when the **RCEL** pressure exceeds 10 in-Hg-A (at sea level, adjust this value accordingly for elevated locations).

- A pump rebuild kit is available from the factory. Refer to the label on the pump for the part number. Instructions and diagrams are included in the kit.
- A flow and leak check after rebuilding the sample pump is recommended.
- A span check and re-calibration after this procedure is necessary as the response of the analyzer changes with the **RCEL** pressure.

11.3.4.2. Replacing the Scrubber



CAUTION!

Do NOT attempt to change the contents of the inline exhaust scrubber cartridge; change the entire cartridge.

1. Through the SETUP>MORE>DIAG menu turn OFF the OZONE GEN OVERRIDE. Wait 10 minutes to allow pump to pull room air through scrubber before proceeding to step 2.
2. Disconnect exhaust line from analyzer.
3. Turn off (unplug) analyzer sample pump.
4. Disconnect tubing from (NOx or charcoal) scrubber cartridge.
5. Remove scrubber from system.
6. Dispose of according to local laws.
7. Install new scrubber into system.
8. Reconnect tubing to scrubber and analyzer.
9. Turn on pump.
10. Through the SETUP menu (per Step 1 above) turn ON the OZONE GEN OVERRIDE.

11.3.5. CHANGING THE PUMP DFU FILTER

The exhaust air from the analyzer passes a small particle filter (Dry Filter Unit (*DFU* - filter), P/N FL3) before entering the pump. It should be replaced when:

- It becomes visibly dirty or;

- The pressure differential between the test functions **SAMP** and **RCEL** increases significantly.

11.3.5.1. Procedure for Replacing Filters on External Pumps

1. Power down the analyzer and pump.
2. For internally mounted filters, skip the next two steps.
3. Remove the analyzer exhaust tube from the dust filter.
4. Remove the particle filter from the pump by pushing the white plastic ring into the fitting and pulling the filter out of the fitting.
 - If necessary, use needle-nose pliers to pry the filter out of the fittings.
5. Push a new filter into the pump fitting and ensure that the arrow on the filter points towards the pump.
6. Push the exhaust tubing onto the filter. Skip the next two steps.
7. For internally mounted filters at the inside rear panel, remove the chassis and locate the filter between the vacuum manifold and the exhaust port fitting.
8. Disconnect the clear tubing from the filter body and change the filter with the arrow pointing against the gas flow. To remove the hose clamps, slide the two clamp ends in opposite directions with a needle-nose pliers until the clamp comes apart. Reconnect the tubing by using the same or new clamps and pushing tightening them until a good seal is achieved.
9. Restart the pump and clear any error warnings from the front panel display.
10. After about 5 minutes, check the RCEL pressure reading and ensure that it is similar to its value before changing the filter but less than 10 in-Hg-A.

11.3.5.2. Procedure for Replacing Filters on Internal Pumps

1. Power down the analyzer and pump.
2. Remove the chassis top and locate the filter between the vacuum manifold and the exhaust port fitting.
3. Disconnect the clear tubing from the filter body and change the filter with the arrow pointing against the gas flow.
4. To remove the hose clamps, slide the two clamp ends in opposite directions with a needle-nose pliers until the clamp comes apart.
5. Reconnect the tubing by using the same or new clamps and pushing tightening them until a good seal is achieved.
6. Restart the pump and clear any error warnings from the front panel display.
7. After about 5 minutes, check the **RCEL** pressure reading and ensure that it is similar to its value before changing the filter (but less than 10 in-Hg-A).

11.3.6. CHANGING THE INTERNAL SPAN GAS GENERATOR PERMEATION TUBE

1. Turn off the analyzer, unplug the power cord and remove the cover.
2. Locate the permeation tube (see Figure 3-5) oven in the rear left of the analyzer.
3. Remove the top layer of insulation if necessary.
4. Unscrew the black aluminum cover of the oven (3 screws) using a medium Phillips-head screw driver.
 - Leave the fittings and tubing connected to the cover.
5. Remove the old permeation tube and replace it with the new tube.
 - Ensure that the tube is placed into the larger of two holes and that the open permeation end of the tube (plastic) is facing up.
6. Re-attach the cover with three screws.
 - Ensure that the three screws are tightened evenly.
7. Replace the analyzer cover, plug the power cord back in and turn on the analyzer.
8. Carry out a span check to see if the new permeation device works properly (see Section 9.3.4).
9. The permeation rate may need several days to stabilize.

ATTENTION

COULD DAMAGE INSTRUMENT AND VOID WARRANTY

Do not leave instrument turned off for more than 8 hours without removing the permeation tube. Do not ship the instrument without removing the permeation tube. The tube continues to emit NO₂, even at room temperature and will contaminate the entire instrument.

11.3.7. CHANGING THE EXTERNAL ZERO AIR SCRUBBER (OPT 86C)

The external zero air scrubber that is included with several of the 9110T's optional calibration valve packages contains two chemicals:

- Pink Purafil[®] (P/N CH 9) that converts NO in the ambient air to NO₂, and;
- Black, charcoal (P/N CH 1) that absorbs the NO₂ thereby creating zero air.

These chemicals need to be replaced periodically (see Table 11-1) or as needed.

**CAUTION!**

The following procedures apply only to the External Zero Air Scrubber and NOT to the inline exhaust scrubber cartridge that is part of the pump pack assembly.

IMPORTANT**IMPACT ON READINGS OR DATA**

This procedure can be carried out while the instrument is running, however ensure that the analyzer is not in ZERO calibration mode.

1. Locate the scrubber on the outside rear panel; Figure 11-4 shows the exploded assembly.
2. Remove the old scrubber by disconnecting the 1/4" plastic tubing from the DFU particle filter using 9/16" and 1/2" wrenches.
3. Remove the DFU particle filter from the cartridge using 9/16" wrenches.
4. Unscrew the top of the scrubber canister and discard the Purafil[®] and charcoal contents.
 - Ensure to abide to local laws about discarding these chemicals.
 - The rebuild kit (listed in Appendix B) comes with a Material and Safety Data Sheet, which contains more information on these chemicals.
5. It is not necessary to remove the insert from the barrel, but if removed, perform the following procedure:
 - Coat the threads of the insert with epoxy (TAI P/N CH32).
 - Hand tighten insert to barrel.
6. It is not necessary to remove the nylon tube fitting from the insert, but if removed, apply Teflon tape (TAI P/N HW36) to the threads of the nylon tube fitting before installing on the insert.
7. Refill the scrubber with charcoal at the bottom and the Purafil[®] chemical at the top.
 - Use three, white retainer pads to separate the chemicals as shown Figure 11-4
8. Replace the screw-top cap and tighten the cap; hand-tighten only.
9. If necessary, replace the filter with a new unit and discard the old. See Section 11.3.7.1.
 - The bottom retainer pad should catch most of the dust, the filter should not be visibly dirty (on the inside).
10. Replace the scrubber assembly into its clips on the rear panel.
11. Reconnect the plastic tubing to the fitting of the DFU particle filter.
12. Adjust the scrubber cartridge such that it does not protrude above or below the analyzer in case the instrument is mounted in a rack.

- If necessary, squeeze the clips for a tighter grip on the cartridge.

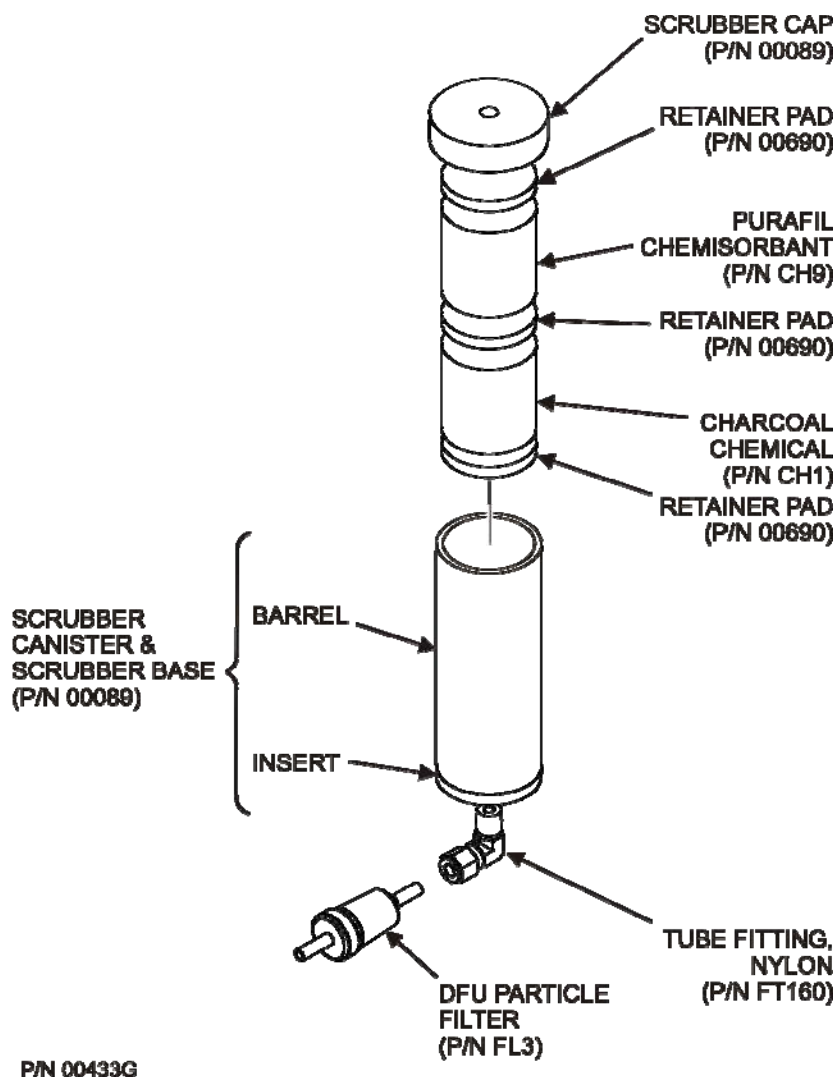

Figure 11-4: Zero Air Scrubber Assembly

11.3.7.1. Changing the External Scrubber's DFU Filter

There is also a DFU filter on the inlet of the external zero air scrubber that is included in several of the optional calibration valve packages.

To change this filter:

1. Disconnect the tube and fitting from one end and remove the filter from the scrubber canister.
2. Insert a new filter and reattach the tubing.
3. Ensure that the small arrow embedded on the filter points in flow direction, i.e., to analyzer.

11.3.8. CHANGING THE NO₂ CONVERTER

The NO₂ converter is located in the center of the instrument, Figure 3-5 for the location, and Figure 11-5 for the assembly.

The converter is designed for replacement of the cartridge only; the heater with built-in thermocouple is to be reused.



CAUTION!

Wear gloves prior to changing the NO₂ Converter to ensure that the fiberglass insulation does not come into contact with your skin.

1. Turn off the analyzer power.
2. Remove the instrument cover and allow the converter to cool.
3. Remove the converter assembly cover as well as the Moly insulation (top layer and corner cut out layers) until the Moly converter assembly can be seen.



CAUTION HOT SURFACE HAZARD

The converter operates at 315° C. Severe burns can result if the assembly is not allowed to cool.

Do not handle the assembly until it is at room temperature. This may take several hours

4. Remove the tube fittings from the Moly converter assembly.
5. Disconnect the power and the thermocouple from the Moly converter assembly.
6. Unscrew the steel cable clamp (for the power leads) from the converter housing with a Phillips-head screw driver.
7. Remove the Moly converter assembly (converter cartridge and band heater) from the converter housing.
 - Make a note of the orientation of the tubes relative to the heater cartridge.
8. Unscrew the band heater and loosen it.
9. Remove the old converter cartridge.

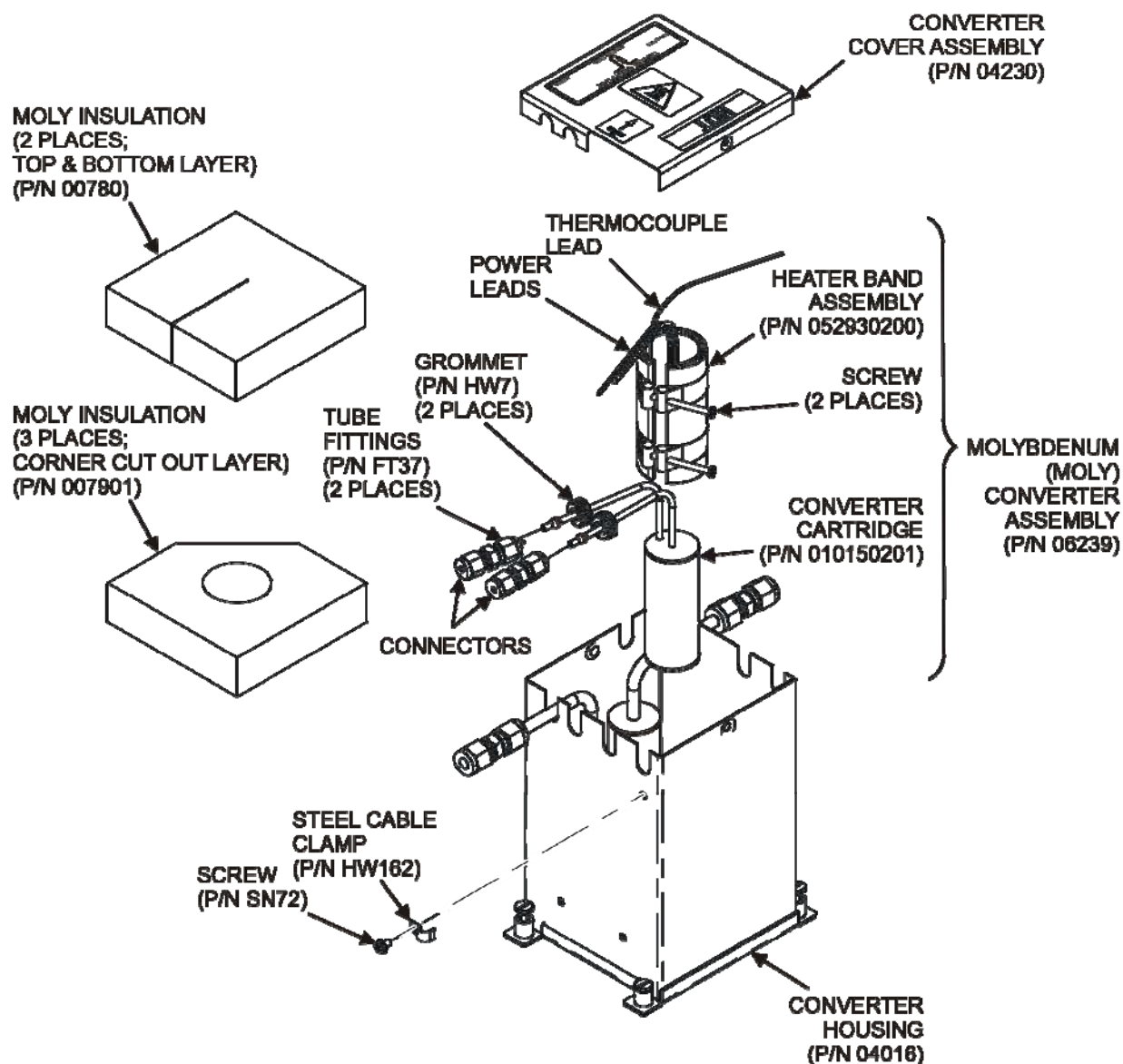

Figure 11-5: NO₂ Converter Assembly

10. Wrap the band heater around the new replacement converter cartridge and tighten the screws using a high-temperature anti-seize agent (TAI P/N CH42) such as copper paste.
 - Ensure to use proper alignment of the heater with respect to the converter tubes.
11. Replace the Moly converter assembly by routing the cables through the holes in the converter housing and reconnecting them properly.
12. Reconnect the steel cable clamp around the power leads for safe operation.
13. Reattach the tube fittings to the converter and replace the Moly insulation (top layer and corner cut out layers).
14. Reinstall the converter assembly cover.

15. Reinstall the instrument cover and power up the analyzer.
16. Allow the converter to burn-in for 24 hours, and then recalibrate the instrument.

11.3.9. CLEANING THE REACTION CELL

A dirty reaction cell will cause excessive noise, drifting zero or span values, low response or a combination of all.

To clean the reaction cell, it is necessary to remove it from the sensor housing.

1. Turn off the instrument power and vacuum pump. Refer to Figure 11-6 for the following procedure.
2. Disconnect the black 1/4" exhaust tube and the 1/8" sample and ozone air tubes from the reaction cell. Disconnect the heater/thermistor cable.
3. Remove two screws (TAI P/N SN144) and two washers holding the reaction cell to the PMT housing and lift the cell and manifold out.

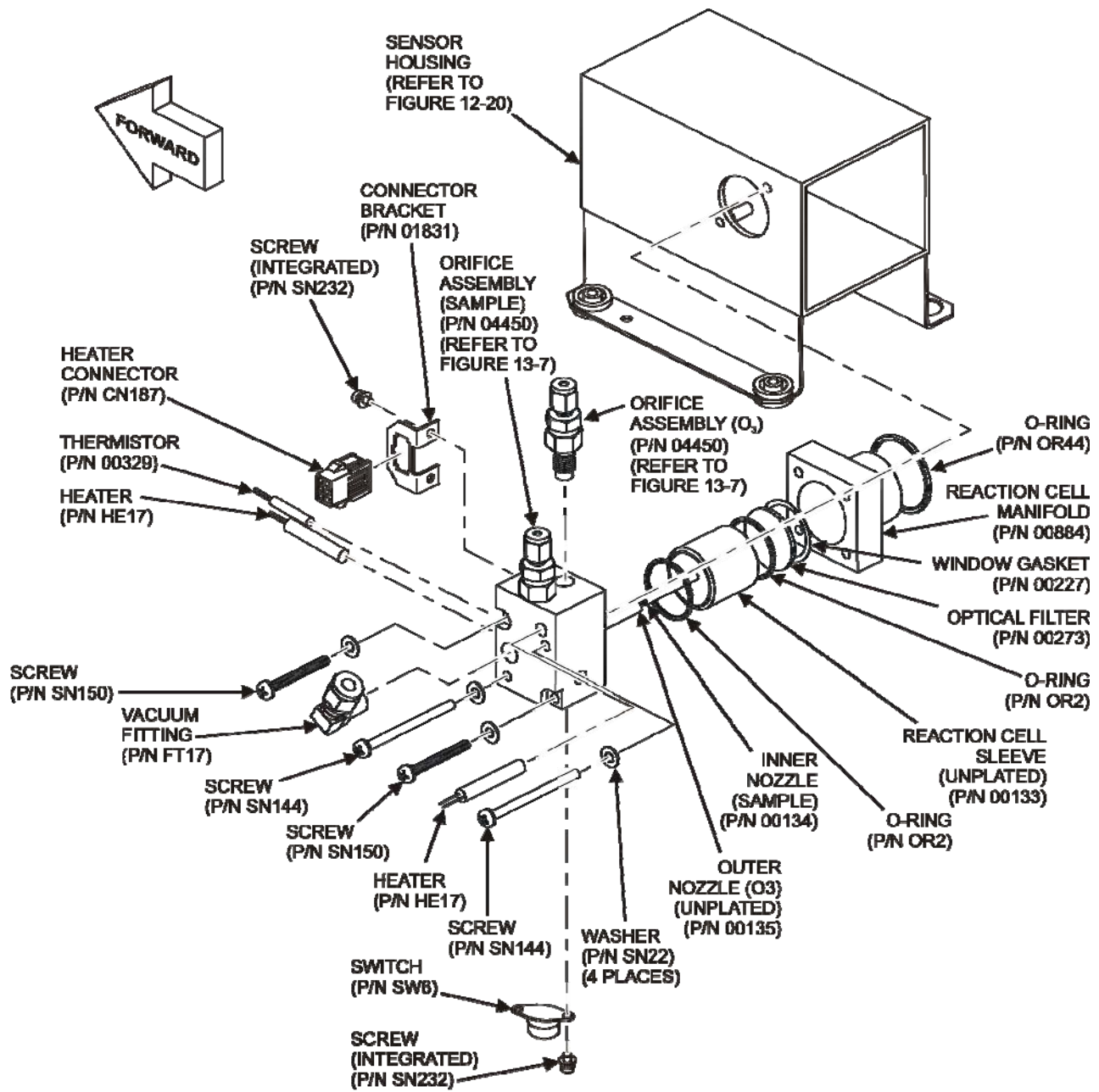

P/N D114205

Figure 11-6: Reaction Cell Assembly

4. Remove two screws (Teledyne P/N SN150) and two washers.
5. The reaction cell will separate into two halves, the stainless steel manifold assembly and the black plastic reaction cell with window gasket, stainless steel reaction cell sleeve, optical filter and O-rings.
6. The reaction cell (both plastic part and stainless steel sleeve) and optical filter should be cleaned with Distilled Water (DI - Water) and a clean tissue, and dried thereafter.
7. Usually it is not necessary to clean the sample and ozone flow orifices since they are protected by sintered filters.

- If tests show that cleaning is necessary, refer to Section 11.3.10 on how to clean the critical flow orifice.
8. Do not remove the sample and ozone nozzles. They are Teflon threaded and require a special tool for reassembly. If necessary, the manifold with nozzles attached can be cleaned in an ultrasonic bath.
 9. Reassemble in proper order and re-attach the reaction cell to the sensor housing. Reconnect pneumatics and heater connections, then re-attach the pneumatic sensor assembly and the cleaning procedure is complete.
 10. After cleaning the reaction cell, it is also recommended to exchange the ozone supply air filter chemical as described in Section 11.3.3.
 11. After cleaning, the analyzer span response may drop 10 - 15% in the first 10 days as the reaction cell window conditions. This is normal and does not require another cleaning.

11.3.10. REPLACING CRITICAL FLOW ORIFICES

There are several critical flow orifices installed in the 9110T (see Figure 13-9 for a pneumatic location of each orifice). Despite the fact that these flow restrictors are protected by sintered stainless steel filters, they can, on occasion, clog up, particularly if the instrument is operated without sample filter or in an environment with very fine, sub-micron particle-size dust.

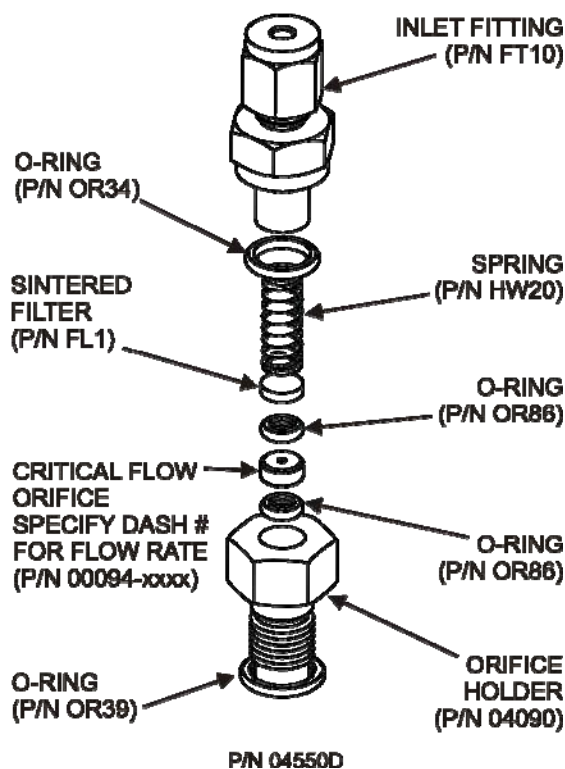

Figure 11-7: Critical Flow Orifice Assembly

To clean or replace a critical flow orifice:

1. Turn off power to the instrument and vacuum pump.
2. Remove the analyzer cover and locate the reaction cell (Figure 11-5 and Figure 11-6).
3. Unscrew the 1/8" sample and ozone air tubes from the reaction cell.
4. For orifices on the reaction cell (Figure 11-6): Unscrew the orifice holder with a 9/16" wrench.
 - This part holds all components of the critical flow assembly as shown in Figure 11-7.
 - Appendix B contains a list of spare part numbers.
5. For orifices in the vacuum manifold: the assembly is similar to the one shown in Figure 11-7, except:
 - Without the orifice holder, P/N 04090, and bottom O-ring, P/N OR34 and;
 - With an NPT fitting in place of the FT 10 fitting.
6. After taking off the connecting tube, unscrew the NPT fitting.
7. Take out the components of the assembly:
 - spring
 - sintered filter
 - two O-rings
 - the orifice

Note

For the vacuum manifold only, you may need to use a scribe or pressure from the vacuum port to get the parts out of the manifold.

8. Discard the two O-rings and the sintered filter and install new ones.
9. Reassemble the parts as shown in Figure 11-7.
10. Reinstall the critical flow orifice assembly into the reaction cell manifold or the vacuum manifold.
11. Reconnect all tubing, power up the analyzer and pump. After a warm-up period of 30 minutes, carry out a leak test as described in Section 13.3.12.

11.3.11. CHECKING FOR LIGHT LEAKS

When re-assembled or operated improperly, the 9110T can develop small gaps around the PMT, which let stray light from the analyzer surrounding into the PMT housing. To find such light leaks, follow the procedures below.

**CAUTION – QUALIFIED PERSONNEL ONLY**

This procedure is carried out with the analyzer running and its cover removed.

1. Scroll the front panel display to show then test function to **PMT**.
2. Supply zero gas to the analyzer.
3. With the instrument still running, carefully remove the analyzer cover.

**WARNING – ELECTRICAL SHOCK HAZARD**

**Do NOT touch any of the inside wiring with the metal cover or with your body.
Do NOT drop screws or tools into a running analyzer.**

4. Shine a powerful flashlight or portable incandescent light at the inlet and outlet fitting and at all of the joints of the reaction cell as well as around the PMT housing.
 - The PMT value should not respond to the light, the PMT signal should remain steady within its usual noise floor.
5. If there is a PMT response to the external light, symmetrically tighten the reaction cell mounting screws or replace the 1/4" vacuum tubing with new, black PTFE tubing (this tubing will fade with time and become transparent).

Note

Often, light leaks are also caused by O-rings being left out of the assembly.

6. If, during this procedure, the black PMT housing end plate for the Sensor Assembly is removed, ensure to replace the 5 desiccant bags inside the housing.
7. Carefully replace the analyzer cover. If tubing was changed, carry out a pneumatic leak check.

11.3.12. CHECKING FOR PNEUMATIC LEAKS**CAUTION - TECHNICAL INFORMATION**

Do not exceed 15 psi when pressurizing the system during either Simple or Detailed checks.

11.3.12.1. Simple Vacuum Leak and Pump Check

Leaks are the most common cause of analyzer malfunction. This section presents a simple leak check, whereas the next section details a more thorough procedure. The method described here is easy, fast and detects, but does not locate, most leaks. It also verifies the sample pump condition.

1. Turn the analyzer ON, and allow at least 30 minutes for flows to stabilize.
2. Cap the sample inlet port (cap must be wrench-tight).
3. After several minutes, when the pressures have stabilized, note the SAMP (sample pressure) and the RCEL (vacuum pressure) readings.

- If both readings are equal to within 10% and less than 10 in-Hg-A, the instrument is free of large leaks.
- It is still possible that the instrument has minor leaks.
- If both readings are < 10 in-Hg-A, the pump is in good condition.
- A new pump will create a pressure reading of about 4 in-Hg-A (at sea level).

11.3.12.2. Detailed Pressure Leak Check

If a leak cannot be located by the above procedure, obtain a leak checker similar to Teledyne P/N 01960, which contains a small pump, shut-off valve, and pressure gauge to create both over-pressure and vacuum. Alternatively, a tank of pressurized gas, with the two-stage regulator adjusted to ≤ 15 psi, a shutoff valve and a pressure gauge may be used.

ATTENTION

COULD DAMAGE INSTRUMENT AND VOID WARRANTY

Once tube fittings have been wetted with soap solution under a pressurized system, do not apply or reapply vacuum as this will cause soap solution to be sucked into the instrument, contaminating inside surfaces.

1. Turn OFF power to the instrument and remove the instrument cover.
2. Install a leak checker or a tank of gas (compressed, oil-free air or nitrogen) as described above on the sample inlet at the rear panel.
3. Disconnect the pump tubing on the outside rear panel and cap the pump port.
 - If IZS or zero/span valves are installed, disconnect the tubing from the zero and span gas ports and plug them (Figure 3-3).
 - Cap the DFU particle filter on the Perma Pure dryer.
4. Pressurize the instrument with the leak checker or tank gas, allowing enough time to fully pressurize the instrument through the critical flow orifice.
 - Check each tube connection (fittings, hose clamps) with soap bubble solution, looking for fine bubbles.
 - Once the fittings have been wetted with soap solution, do not reapply vacuum as it will draw soap solution into the instrument and contaminate it.
 - Do not exceed 15 psi pressure.
5. If the instrument has the zero and span valve option, the normally closed ports on each valve should also be separately checked.
 - Connect the leak checker to the normally closed ports and check with soap bubble solution.

6. If the analyzer is equipped with an IZS Option Connect the leak checker to the Dry Air inlet and check with soap bubble solution.
7. Once the leak has been located and repaired, the leak-down rate of the indicated pressure should be less than 1 in-Hg-A (0.4 psi) in 5 minutes after the pressure is turned off.
8. Clean surfaces from soap solution, reconnect the sample and pump lines and replace the instrument cover.
9. Restart the analyzer.

11.3.12.3. Performing a Sample Flow Check

IMPORTANT**IMPACT ON READINGS OR DATA**

Use a separate, calibrated flow meter capable of measuring flows between 0 and 1000 cm³/min to measure the gas flow rate through the analyzer. Do not use the built in flow measurement viewable from the front panel of the instrument.

This value is only calculated, not measured.

Sample flow checks are useful for monitoring the actual flow of the instrument, as the front panel display shows only a calculated value. A decreasing, actual sample flow may point to slowly clogging pneumatic paths, most likely critical flow orifices or sintered filters. To perform a sample flow check:

1. Disconnect the sample inlet tubing from the rear panel SAMPLE port.
2. Attach the outlet port of a flow meter to the sample inlet port on the rear panel.
 - Ensure that the inlet to the flow meter is at atmospheric pressure.
3. The sample flow measured with the external flow meter should be 500 cm³/min ± 10%.
 - If a combined sample/ozon air Perma Pure dryer is installed (optional equipment), the flow will be 640 cm³/min ± 10% (500 cm³/min for the sample and 80 cm³/min for the ozon generator supply air and 60 cm³/min for the purge flow).
4. Low flows indicate blockage somewhere in the pneumatic pathway.

12. TROUBLESHOOTING & SERVICE

This section contains a variety of methods for identifying the source of performance problems with the analyzer. Also included in this section are procedures that are used in repairing the instrument.

Note:

To support your understanding of the technical details of maintenance, Section 13, *Principles of Operation*, provides information about how the instrument works.

**CAUTION**

The operations outlined in this section must be performed by qualified maintenance personnel only.

**WARNING
RISK OF ELECTRICAL SHOCK**

Some operations need to be carried out with the analyzer open and running.

Exercise caution to avoid electrical shocks and electrostatic or mechanical damage to the analyzer.

Do not drop tools into the analyzer or leave those after your procedures.

Do not short or touch electric connections with metallic tools while operating inside the analyzer.

Use common sense when operating inside a running analyzer.

Note

The front panel of the analyzer is hinged at the bottom and may be opened to gain access to various components mounted on the panel itself or located near the front of the instrument (such as the particulate filter).

Remove the locking screw located at the right-hand side of the front panel.

12.1. GENERAL TROUBLESHOOTING

The 9110T Nitrogen Oxide analyzer has been designed so that problems can be rapidly detected, evaluated and repaired. During operation, it continuously performs diagnostic tests and provides the ability to evaluate its key operating parameters without disturbing monitoring operations.

A systematic approach to troubleshooting will generally consist of the following five steps:

1. Note any **WARNING MESSAGES** and take corrective action as necessary.
2. Examine the values of all TEST functions and compare them to factory values. Note any major deviations from the factory values and take corrective action.
3. Use the internal electronic status LEDs to determine whether the electronic communication channels are operating properly.
 - Verify that the DC power supplies are operating properly by checking the voltage test points on the relay PCA.
 - Note that the analyzer's DC power wiring is color-coded and these colors match the color of the corresponding test points on the relay PCA.
4. Suspect a leak first!
 - Customer service data indicate that the majority of all problems are eventually traced to leaks in the internal pneumatics of the analyzer or the diluent gas and source gases delivery systems.
 - Check for gas flow problems such as clogged or blocked internal/external gas lines, damaged seals, punctured gas lines, a damaged / malfunctioning pumps, etc.
5. Follow the procedures defined in Section 3.4.3 to confirm that the analyzer's vital functions are working (power supplies, CPU, relay PCA, touchscreen, PMT cooler, etc.).
 - See Figure 3-5 or the general layout of components and sub-assemblies in the analyzer.
 - See the wiring interconnect diagram and interconnect list in Appendix D.

12.1.1. FAULT DIAGNOSIS WITH WARNING MESSAGES

The most common and/or serious instrument failures will result in a warning message being displayed on the front panel. Table 12-1 lists warning messages, along with their meaning and recommended corrective action.

It should be noted that if more than two or three warning messages occur at the same time, it is often an indication that some fundamental sub-system (power supply, relay PCA, motherboard) has failed rather than an indication of the specific failures referenced by the warnings.

The analyzer will alert the user that a Warning Message is active by flashing the FAULT LED and displaying the Warning message in the Param field along with the **CLR** button (press to clear Warning message). The **MSG** button displays if there is more than one warning in queue or if you are in the TEST menu and have not yet cleared the message.

The following display/touch screen examples provide an illustration of each:



The analyzer will also alert the user via the Serial I/O COMM port(s).

To view or clear the various warning messages press:

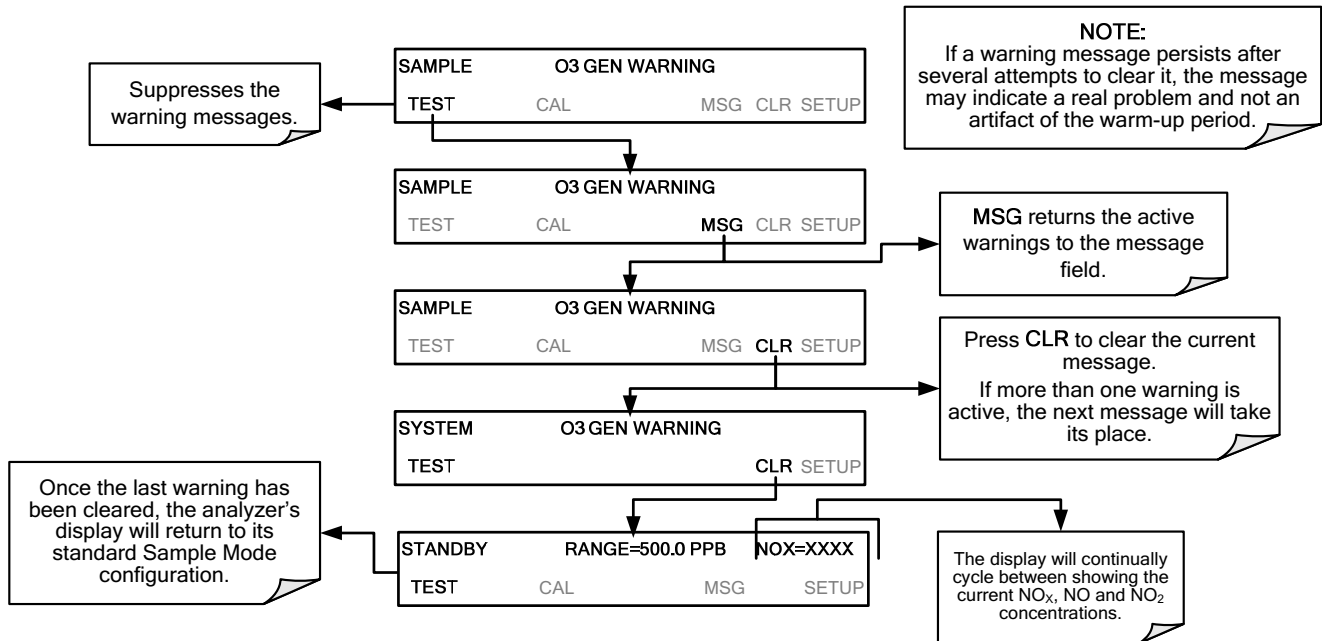

Table 12-1: Front Panel Warning Messages

WARNING	FAULT CONDITION	POSSIBLE CAUSES
AZERO WARN XXX.X MV	Auto-zero reading above 200 mV. Value shown in message indicates auto-zero reading at time warning was displayed.	AZERO valve not working Valve control driver failed Bad Relay PCA Failed +12 VDC power supply Gas leak across AZERO Valve ports Dirty Reaction Cell O ₃ flow problem to RCELL
BOX TEMP WARNING	Box Temp is < 7°C or > 48°C.	Box Temperature typically runs ~7°C warmer than ambient temperature Poor/blocked ventilation to the analyzer Stopped Exhaust-Fan Ambient Temperature outside of specified range
CANNOT DYN SPAN	Dynamic Span operation failed.	Measured concentration value is too high or low Concentration Slope value to high or too low
CANNOT DYN ZERO	Dynamic Zero operation failed.	Measured concentration value is too high Concentration Offset value to high
CONFIG INITIALIZED	Configuration and Calibration data reset to original Factory state.	Failed Disk on Module User erased data
CONV TEMP WARNING	NO ₂ → NO Converter temperature < 305°C or > 325°C.	Heater configured for wrong voltage type Failed converter Temperature Sensor Relay controlling the Heater is not working Failed Relay Board
DATA INITIALIZED	Data Storage in DAS was erased.	Failed Disk-on-Module User cleared data.
HVPS WARNING	High voltage power supply output outside of warning limits specified by <i>HVPS_SET</i> variable.	No +15 VDC power supply to Preamp PCA Drive voltage not adjusted properly Failed PMT Preamp PCA Dirty reaction cell Bad pneumatic flow
IZS TEMP WARNING	Permeation tube oven temperature is < 45°C or > 55°C.	Heater configured for wrong voltage type Failed permeation tube Temperature Sensor Relay controlling the Heater is not working Failed Relay Board
OZONE FLOW WARNING	O ₃ flow rate is < 50 cc/min or > 150 cc/min.	Failed Sample Pump Blocked O ₃ dryer Blocked inlet/outlet to O ₃ purifier Dirty O ₃ dryer DFU Leak downstream of RCELL Failed O ₃ Flow Sensor
OZONE GEN OFF	Ozone generator is off. This is the only warning message that automatically clears itself. It clears itself when the ozone generator is turned on.	O ₃ generator override is turned ON. Electrical connection between motherboard and generator is faulty. Bad +15VDC power supply
PMT TEMP WARNING	Sample temperature is < 5°C or > 12°C.	PMT fan not operating Failed PMT Temperature Sensor TEC not functioning Failed PMT Preamp PCA

WARNING	FAULT CONDITION	POSSIBLE CAUSES
RCELL PRESS WARN	Sample Pressure is <15 in-Hg or > 35 in-Hg Normally 29.92 in-Hg at sea level decreasing at 1 in-Hg per 1000 ft of altitude (with no flow – pump disconnected).	If Sample Pressure is < 15 in-HG: <ul style="list-style-type: none"> •Blocked Particulate Filter •Blocked Sample Inlet/Gas Line •Failed Pressure Sensor/circuitry If Sample Pressure is > 35 in-HG: <ul style="list-style-type: none"> •Bad Pressure Sensor/circuitry •Pressure too high at Sample Inlet.
RCELL TEMP WARNING	RCELL temperature is < 45°C or > 55°C.	Heater configured for wrong voltage type Failed RCELL Temperature Sensor Relay controlling the heater is not working Failed Relay Board I ² C Bus
REAR BOARD NOT DET	Motherboard not detected on power up.	This WARNING only appears on Serial I/O COMM Port(s) Front Panel Display will be frozen, blank or will not respond. Failure of Motherboard
RELAY BOARD WARN	The CPU cannot communicate with the Relay Board.	I ² C Bus failure Failed Relay Board Loose connectors/wiring
SAMPLE FLOW WARN	Sample flow rate is < 350 cc/min or > 600 cc/min.	Failed Sample Pump Blocked Sample Inlet/Gas Line Dirty Particulate Filter Leak downstream of RCELL Critical Flow Orifice Failed Sample Pressure Sensor Failed Vacuum Pressure Sensor
SYSTEM RESET	The computer has rebooted.	This message occurs at power on. If it is confirmed that power has not been interrupted: Failed +5 VDC power Fatal Error caused software to restart Loose connector/wiring

Note

A failure of the analyzer’s CPU, motherboard or power supplies can result in any or ALL of the above messages.

12.1.2. FAULT DIAGNOSIS WITH TEST FUNCTIONS

In addition to being useful as predictive diagnostic tools, the test functions viewable from the analyzers front panel can be used to isolate and identify many operational problems when combined with a thorough understanding of the analyzer's principles of operation (see Section 13).

The acceptable ranges for these test functions are listed in the "Nominal Range" column of the analyzer *Final Test and Validation Data Sheet* (P/N 04490) shipped with the instrument. Values outside these acceptable ranges indicate a failure of one or more of the analyzer's subsystems. Functions whose values are still within acceptable ranges but have significantly changed from the measurement recorded on the factory data sheet may also indicate a failure.

A worksheet has been provided in Appendix C to assist in recording the value of these test functions.

Note A value of "XXXX" displayed for any of these TEST functions indicates an OUT OF RANGE reading.

Note Sample Pressure measurements are represented in terms of ABSOLUTE pressure because this is the least ambiguous method reporting gas pressure.

Absolute atmospheric pressure is about 29.92 in-Hg-A at sea level. It decreases about 1 in-Hg per 1000 ft gain in altitude. A variety of factors such as air conditioning systems, passing storms, and air temperature, can also cause changes in the absolute atmospheric pressure.

Table 12-2: Test Functions - Indicated Failures

TEST FUNCTION	INDICATED FAILURE(S)
NOX STB	Unstable concentrations; leaks
SAMP FIW	Leaks; clogged critical flow orifice
OZONE FL	Leaks; clogged critical flow orifice
PMT	Calibration off; HVPS problem; no flow (leaks)
NORM PMT	Auto Zero too high
AZERO	Leaks; malfunctioning NO, NO _x or Auto Zero valve; O ₃ air filter cartridge exhausted
HVPS	Calibration off; preamp board circuit problems
RCELL TEMP	Malfunctioning heater; relay board communication (I ² C bus); relay burnt out
BOX TEMP	Environment out of temperature operating range; broken thermistor
PMT TEMP	TEC cooling circuit broken; relay board communication (I ² C bus); 12 V power supply
IZS TEMP (option)	Malfunctioning heater; relay board communication (I ² C bus); relay burnt out
MOLY TEMP	Malfunctioning heater; disconnected or broken thermocouple; relay board communication (I ² C bus); relay burnt out; incorrect AC voltage configuration
RCEL (pressure)	Leak; malfunctioning valve; malfunctioning pump; clogged flow orifices
SAMP (pressure)	Leak; malfunctioning valve; malfunctioning pump; clogged flow orifices; sample inlet overpressure
NOX SLOPE	HVPS out of range; low-level (hardware) calibration needs adjustment; span gas

TEST FUNCTION	INDICATED FAILURE(S)
	concentration incorrect; leaks
NOX OFFset	Incorrect span gas concentration; low-level calibration off
NO SLOPE	HVPS out of range; low-level calibration off; span gas concentration incorrect; leaks
NO OFFSet	Incorrect span gas concentration; low-level calibration off
TIME	Internal clock drifting; move across time zones; daylight savings time?

12.1.3. DIAG → SIGNAL I/O: USING THE DIAGNOSTIC SIGNAL I/O FUNCTION

The signal I/O diagnostic mode allows access to the digital and analog I/O in the analyzer. Some of the digital signals can be controlled through the touchscreen. These signals, combined with a thorough understanding of the instrument's principles of operation (Section 13), are useful for troubleshooting in three ways:

- The technician can view the raw, unprocessed signal level of the analyzer's critical inputs and outputs.
- Many of the components and functions that are normally under algorithmic control of the CPU can be manually exercised.
- The technician can directly control the signal level Analog and Digital Output signals.

This allows the technician to observe systematically the effect of directly controlling these signals on the operation of the analyzer. Following is an example of how to use the Signal I/O menu to view the raw voltage of an input signal or to control the state of an output voltage or control signal.

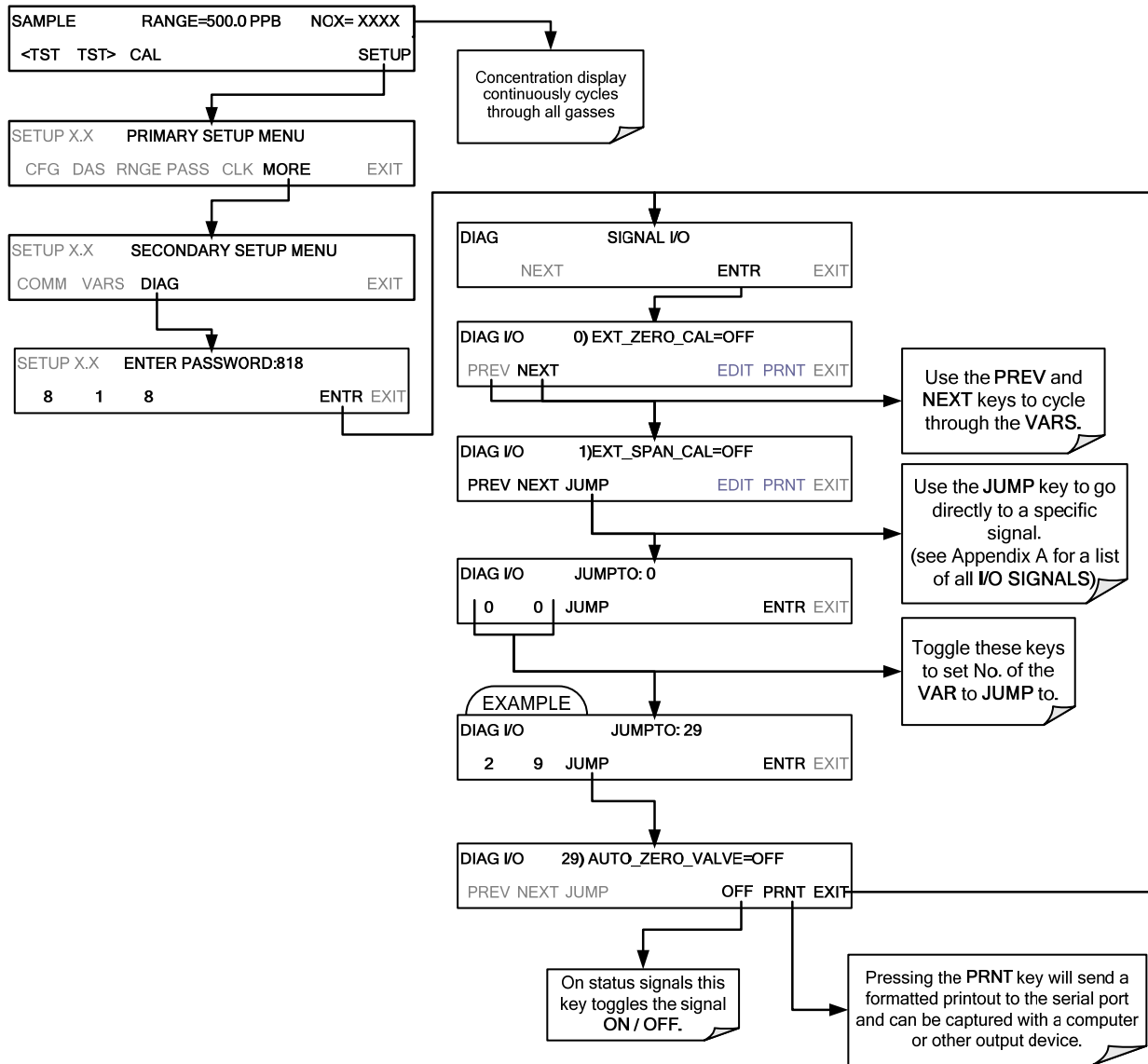

Figure 12-1: Example of Signal I/O Function

Note

Any I/O signals changed while in the signal I/O menu will remain in effect ONLY until signal I/O menu is exited. The Analyzer regains control of these signals upon exit.

See Appendix A for a complete list of the parameters available for review under this menu.

12.2. USING THE ANALOG OUTPUT TEST CHANNEL

The signals available for output over the 9110T's analog output channel can also be used as diagnostic tools. See Section 5.9.2 for instruction on activating the analog output and selecting a function.

Table 12-3: Test Channel Outputs as Diagnostic Tools

TEST CHANNEL	DESCRIPTION	ZERO	FULL SCALE	CAUSES OF EXTREMELY HIGH / LOW READINGS
PMT DETECTOR	The output of the PMT detector converted to a 0 to 5 VDC scale.	0 mV	5000 mV	Failed PMT PMT Temperature too High/Low Bad PMT Preamp PCA Failed HVPS Misadjusted HVPS drive Voltage Light Leak in reaction cell
OZONE FLOW	The flow rate of O ₃ through the analyzer as measured by the O ₃ flow sensor	0 cm³/min	1000 cm³/min	Check for Gas Flow problems in the O ₃ gas lines.
SAMPLE FLOW	The calculated flow rate for sample gas through the analyzer.	0 cm³/min	1000 cm³/min	Check for Gas Flow problems in the sample gas lines.
SAMPLE PRESSURE	The pressure of the sample gas measured upstream of the Auto Zero Valve	0 In-Hg-A	40 In-Hg-A	Check for Gas Flow problems in the sample gas lines.
RCELL PRESSURE	The pressure of gas inside the reaction cell of the sensor module	0 In-Hg-A	40 In-Hg-A	Check for Gas Flow problems in all gas lines.
RCELL TEMP	The temperature of gas inside the reaction cell of the sensor module	0 °C	70 °C	Same as RCELL TEMP WARNING in Table 12-1.
IZS TEMP	The temperature of the permeation tube oven of the optional internal span gas generator.	0 °C	70 °C	Same as IZS TEMP WARNING in Table 12-1.
CONV TEMP	The temperature NO ₂ → NO converter	0 mV	5000 mV	Same as CONV TEMP WARNING in Table 12-1.
PMT TEMP	The temperature inside PMT	0 °C	50 °C	Same as PMT TEMP WARNING in Table 12-1.
BOX TEMP	The temperature inside the 9110T's chassis	0 °C	70 °C	Same as BOX TEMP WARNING in Table 12-1.
HVPS VOLTAGE	Represents the output voltage of the PMT's high voltage power supply	0 mV	5000 mV	Same as HVPSWARNING in Table 12-1.

12.3. USING THE INTERNAL ELECTRONIC STATUS LEDS

Several LEDs are located inside the instrument to assist in determining if the analyzer’s CPU, I²C bus and Relay PCA are functioning properly.

12.3.1. CPU STATUS INDICATOR

DS5, a red LED, that is located on upper portion of the motherboard, just to the right of the CPU board, flashes when the CPU is running the main program loop. After power-up, approximately 30 – 60 seconds, DS5 should flash on and off. If characters are written to the front panel display but DS5 does not flash then the program files have become corrupted, contact TAI's Customer Service Department (see Section 12.10) because it may be possible to recover operation of the analyzer. If after 30 – 60 seconds, neither DS5 is flashing nor have any characters been written to the front panel display then the CPU is bad and must be replaced.

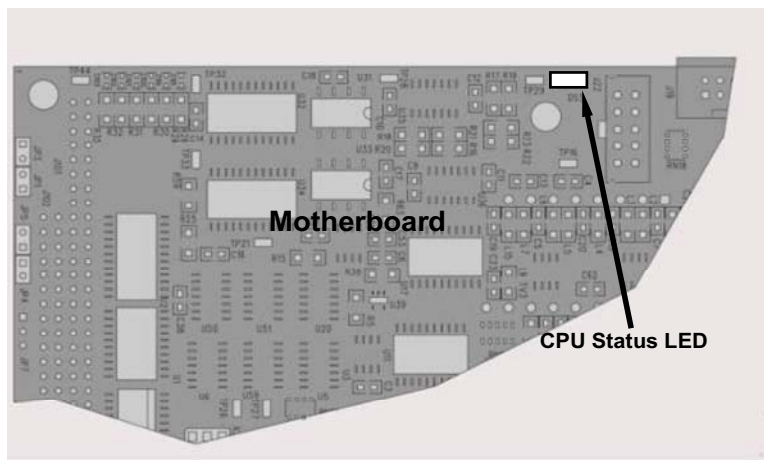

Figure 12-2: CPU Status Indicator

12.3.2. RELAY PCA STATUS LEDS

There are sixteen LEDs located on the Relay PCA. Some are not used on this model.

12.3.2.1. I²C Bus Watchdog Status LEDs

The most important is D1, which indicates the health of the I²C bus.

Table 12-4: Relay PCA Watchdog LED Failure Indications

LED	Function	Fault Status	Indicated Failure(s)
D1 (Red)	I ² C bus Health (Watchdog Circuit)	Continuously ON or Continuously OFF	Failed/Halted CPU Faulty Motherboard, Touchscreen or Relay PCA Faulty Connectors/Wiring between Motherboard, Touchscreen or Relay PCA Failed/Faulty +5 VDC Power Supply (PS1)

If D1 is blinking, then the other LEDs can be used in conjunction with **DIAG** Menu Signal I/O to identify hardware failures of the relays and switches on the Relay PCA.

12.3.2.2. Relay PCA Status LEDs

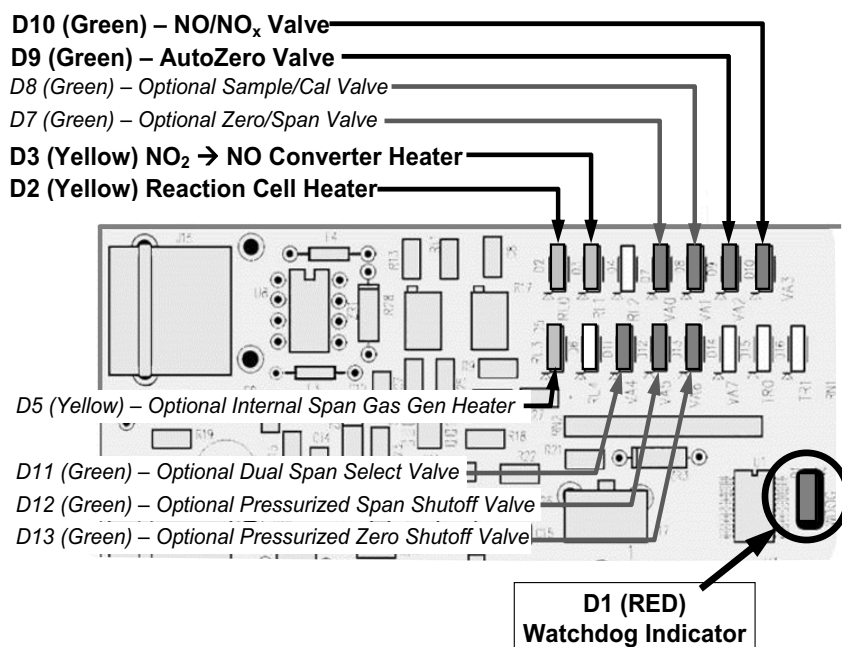

Figure 12-3: Relay PCA Status LEDs Used for Troubleshooting

Table 12-5: Relay PCA Status LED Failure Indications

LED	COLOR	FUNCTION	FAULT STATUS	INDICATED FAILURE(S)
LED ROW 1				
D2	Yellow	Reaction Cell heater	Continuously ON or OFF	Heater broken, thermistor broken
D3	Yellow	NO ₂ converter heater	Continuously ON or OFF	Heater broken, thermocouple broken
D7	Green	Zero/Span valve status	Continuously ON or OFF	Valve broken or stuck, valve driver chip broken
D8	Green	Sample/Cal valve status	Continuously ON or OFF	Valve broken or stuck, valve driver chip broken
D9	Green	Auto-zero valve status	Continuously ON or OFF	Valve broken or stuck, valve driver chip broken
D10	Green	NO/NO _x valve status	Continuously ON or OFF	Valve broken or stuck, valve driver chip broken
LED ROW 2				
D5	Yellow	Internal span gas generator perm tube heater	Continuously ON or OFF	Heater broken, thermistor broken
D11	Green	Dual span select valve	Continuously ON or OFF	Valve broken or stuck, valve driver chip broken
D12	Green	Pressurized Span shutoff valve	Continuously ON or OFF	Valve broken or stuck, valve driver chip broken
D13	Green	Pressurized Zero shutoff valve	Continuously ON or OFF	Valve broken or stuck, valve driver chip broken
D14- 16	Green	Spare	N/A	N/A

12.4. GAS FLOW PROBLEMS

The 9110T has two main flow paths, the sample flow and the flow of the ozone supply air. With IZS or zero/span valve option installed, there is a third (zero air) and a fourth (span gas) flow path, but either one of those is only controlled by critical flow orifices and not displayed on the front panel or stored to the DAS.

- Flow is too high
- Flow is greater than zero, but is too low, and/or unstable
- Flow is zero (no flow)

When troubleshooting flow problems, it is essential to confirm the actual flow rate without relying on the analyzer's flow display. The use of an independent, external flow meter to perform a flow check as described in Section 11.3.12.3 is essential. Refer to the pneumatic flow diagrams as needed for reference.

12.4.1. ZERO OR LOW FLOW PROBLEMS

12.4.1.1. Sample Flow is Zero or Low

The 9110T does not actually measure the sample flow but rather calculates it from a differential pressure between sample and vacuum manifold. On flow failure, the unit will display a **SAMPLE FLOW WARNING** on the front panel display and the respective test function reports **XXXX** instead of a value "0". This message applies to both a flow rate of zero as well as a flow that is outside the standard range (350-600 cm³/min).

If the analyzer displays **XXXX** for the sample flow, confirm that the external sample pump is operating and configured for the proper AC voltage.

- Whereas the 9110T can be internally configured for two different power regimes (100-120 V and 220-240 V, either 50 or 60 Hz), the external pump is physically different for each of three power regimes (100 V / 50 Hz, 115 V / 60 Hz and 230 V / 50 Hz).
- If the pump is not running, use an AC Voltmeter to ensure that the pump is supplied with the proper AC power. If AC power is supplied properly, but the pump is not running, replace the pump.

Note

Sample and vacuum pressures mentioned in this chapter refer to operation of the analyzer at sea level. Pressure values need to be adjusted for elevated locations, as the ambient pressure decreases by about 1 in-Hg per 300 m / 1000 ft.

If the pump is operating but the unit reports a **XXXX** gas flow, take the following three steps:

1. Check for actual sample flow.
 - To check the actual sample flow, disconnect the sample tube from the sample inlet on the rear panel of the instrument.
 - Ensure that the unit is in basic **SAMPLE** mode.
 - Place a finger over the inlet and see if it gets sucked in by the vacuum or, more properly, use a flow meter to measure the actual flow.

- If there is proper flow of around 450-550 cm³/min, contact customer service.
 - If there is no flow or low flow, continue with the next step.
2. Check pressures.
 - Check that the sample pressure is at or around 28 in-Hg-A at sea level (adjust as necessary when in elevated location, the pressure should be about 1" below ambient atmospheric pressure) and that the RCEL pressure is below 10 in-Hg-A.
 - The 9110T will calculate a sample flow up to about 14 in-Hg-A RCEL pressure but a good pump should always provide less than 10 in.
 - If both pressures are the same and around atmospheric pressure, the pump does not operate properly or is not connected properly. The instrument does not get any vacuum.
 - If both pressures are about the same and low (probably under 10 in-Hg-A, or ~20" on sample and 15" on vacuum), there is a cross-leak between sample flow path and vacuum, most likely through the Perma Pure dryer flow paths. See troubleshooting the Perma Pure dryer later in this chapter.
 - If the sample and vacuum pressures are around their nominal values (28 and <10 in-Hg-A, respectively) and the flow still displays XXXX, carry out a leak check as described in Section 13.3.12.
 - If gas flows through the instrument during the above tests but goes to zero or is low when it is connected to zero air or span gas, the flow problem is not internal to the analyzer but likely caused by the gas source such as calibrators/generators, empty gas tanks, clogged valves, regulators and gas lines.
 - If an IZS or Zero/Span valve option is installed in the instrument, press CALZ and CALS. If the sample flow increases, suspect a bad Sample/Cal valve.
 3. If none of these suggestions help, carry out a detailed leak check of the analyzer as described in Section 11.3.12.2.

12.4.1.2. Ozone Flow is Zero or Low

If there is zero or a low (<50 cm³/min) ozone flow, the unit displays an **OZONE FLOW WARNING** message on the front panel and a value between 0.0 and 50 cm³/min for the actual ozone flow as measured by the internal mass flow meter. In this case, carry out the following steps:

1. Check the actual flow rate through the ozone dryer by using an external flow meter to the inlet port of the dryer.
 - This inlet port is inside the analyzer at the end of the plastic particle filter (Section 11.3.2 for illustration).
 - If there is nominal flow (about 160 cm³/min from 80 cm³/min O₃ flow and 80 cm³/min purge flow), consult customer service as there is a problem with the firmware or electronics.

2. If the actual flow is low or zero, check if the pump operates properly. The RCEL pressure should be below 10 in-Hg-A at sea level.
 - If it is above 10", rebuild the pump (Section 11.3.4.1). Check the spare parts list in Appendix B on how to order pump rebuild kits.
3. Check if the particle filter is clogged.
 - Briefly remove the particle filter to see if this improves the flow.
 - Be very cautious when handling the Perma Pure dryer fittings (see Section 11.3.2 on proper handling instructions).
 - If the filter is clogged, replace it with a new unit.
 - If taking off this filter does not solve the problem, continue to the next step.
 - Do not leave the Perma Pure dryer without filter for more than a few seconds, as you may draw in dust, which will reduce the performance of the dryer.
4. A leak between the flow meter and the reaction cell (where the flow-determining critical orifice is located) may cause a low flow (the system draws in ambient air through a leak after the flow meter).
 - Check for leaks as described in Section 11.3.12.
 - Repair the leaking fitting, line or valve and re-check.
5. The most likely cause for zero or low ozone flow is a clogged critical flow orifice or sintered filter within the orifice assembly.
 - The orifice that sets the ozone flow is located on the reaction cell.
 - Check the actual ozone flow by disconnecting the tube from the reaction cell and measuring the flow going into the cell.
 - If this flow is correct (~80 cm³/min), the orifice works properly.
 - If this flow is low, replace the sintered filter.
 - The orifice holder assembly allows a quick and easy replacement of the filter (see Section 11.3.5 and on for replacement procedures).
 - Appendix B lists a spare part kit with a complete orifice assembly that allows a quick replacement with minimum instrument down-time.

12.4.1.3. High Flow

Flows that are significantly higher than the allowed operating range (typically ± 10 -11% of the nominal flow) should not occur in the 9110T unless a pressurized sample, zero or span gas is supplied to the inlet ports.

- Ensure to vent excess pressure and flow just before the analyzer inlet ports.

When supplying sample, zero or span gas at ambient pressure, a high flow would indicate that one or more of the critical flow orifices are physically broken (very unlikely case), allowing more than nominal flow, or were replaced with an orifice of wrong specifications.

- If the flows are within 15% higher than normal, we recommend measuring and recalibrating the flow electronically using the procedure in Section 10, followed by a regular review of these flows over time to see if the new setting is retained properly.
- Also, check the flow assembly o-rings and replace as needed.

12.4.1.4. Sample Flow is Zero or Low but Analyzer Reports Correct Flow

Note that the 9110T analyzer can report a correct flow rate even if there is no or a low actual sample flow through the reaction cell.

- The sample flow on the 9110T is only calculated from the sample pressure and critical flow condition is verified from the difference between sample pressure and vacuum pressure.
- If the critical flow orifice assembly is partially or completely clogged, both the sample and vacuum pressures are still within their nominal ranges (the pump keeps pumping, the sample port is open to the atmosphere), but there is no flow possible through the reaction cell.

Although measuring the actual flow is the best method, in most cases, this fault can also be diagnosed by evaluating the two pressure values.

- Since there is no longer any flow, the sample pressure should be equal to ambient pressure, which is about 1 in-Hg-A higher than the sample pressure under normal operation.
- The reaction cell pressure, on the other hand, is significantly lower than under normal operation, because the pump no longer has to remove 500 cm³/min of sample gas and evacuates the reaction cell much better.
- Those two indicators, taken together with a zero or low actual flow, indicate a clogged sample orifice.

The 9110T features a new orifice holder, which makes switching sample and ozone flow orifices very easy; refer to Section 11.3.10 on how to change the sample orifices and to Appendix B for part numbers of these assemblies.

Again, monitoring the pressures and flows regularly will reveal such problems, because the pressures would slowly or suddenly change from their nominal, mean values. Teledyne recommends to review all test data once per week and to do an exhaustive data analysis for test and concentration values once per month, paying particular attention to sudden or gradual changes in all parameters that are supposed to remain constant, such as the flow rates.

12.5. CALIBRATION PROBLEMS

This section describes possible causes of calibration problems.

12.5.1. NEGATIVE CONCENTRATIONS

Negative concentration values can be caused for several reasons:

- A slight, negative signal is normal when the analyzer is operating under zero gas and the signal is drifting around the zero calibration point.
 - This is caused by the analyzer's zero noise and may cause reported concentrations to be negative for a few seconds at a time down to -20 ppb, but should randomly alternate with similarly high, positive values.
 - The 9110T has a built-in Auto Zero function, which should take care of most of these deviations from zero, but may yield a small, residual, negative value.
 - If larger, negative values persist continuously, check if the Auto Zero function was accidentally turned off using the remote variables in Appendix A-2.
 - In this case, the sensitivity of the analyzer may be drifting negative.
- A corruption of the Auto Zero filter may also cause negative concentrations.
 - If a short, high noise value was detected during the Auto Zero cycle, that higher reading will alter the Auto Zero filter value.
 - As the value of the Auto Zero filter is subtracted from the current PMT response, it will produce a negative concentration reading.
 - High Auto Zero readings can be caused by
 - a leaking or stuck Auto Zero valve (replace the valve),
 - by an electronic fault in the preamplifier causing it to have a voltage on the PMT output pin during the Auto Zero cycle (replace the preamplifier),
 - by a reaction cell contamination causing high background (>40 mV) PMT readings (clean the reaction cell),
 - by a broken PMT temperature control circuit, allowing high zero offset (repair the faulty PMT cooler). After fixing the cause of a high Auto Zero filter reading, the 9110T will take 15 minutes for the filter to clear itself, or
 - by an exhausted chemical in the ozone cleanser (see Section 11.3.3).
- Calibration error is the most likely explanation for negative concentration values.
 - If the zero air contained some NO or NO₂ gas (contaminated zero air or a worn-out zero air scrubber) and the analyzer was calibrated to that concentration as "zero", the analyzer may report negative values when measuring air that contains little or no NO_x.
 - The same problem occurs, if the analyzer was zero-calibrated using zero gas that is contaminated with ambient air or span gas (cross-port leaks or leaks in supply tubing or user not waiting long enough to flush pneumatic systems).

- If the response offset test functions for NO (**NO OFFS**) or NO_x (**NOX OFFS**) are greater than 150 mV, a reaction cell contamination is indicated.
- Clean the reaction cell as described in Section 11.3.9.

12.5.2. NO RESPONSE

If the instrument shows no response (display value is near zero) even though sample gas is supplied properly and the instrument seems to perform correctly.

1. Carry out an electrical test with the ELECTRICAL TEST procedure in the diagnostics menu, see Section 12.7.12.2.
 - If this test produces a concentration reading, the analyzer's electronic signal path is correct.
2. Carry out an optical test using the OPTIC TEST procedure in the diagnostics menu, see Section 12.7.12.1.
 - If this test results in a concentration signal, then the PMT sensor and the electronic signal path are operating properly.
 - If the 9110T passes both ETEST and OTEST, the instrument is capable of detecting light and processing the signal to produce a reading.
 - Therefore, the problem must be in the pneumatics or the ozone generator.
3. Check if the ozone generator is turned on.
 - Usually, the analyzer issues a warning whenever the ozone generator is turned off.
 - Go to SETUP-MORE-DIAG-ENTR, then scroll to the OZONE GEN OVERRIDE and see if it shows ON.
 - If it shows OFF, turn it ON and **EXIT** the **DIAG** menu.
 - If this is done and the ozone flow is correct, the analyzer should be properly supplied with ozone unless the generator itself is broken.
4. Confirm the lack of response by supplying NO or NO₂ span gas of about 80% of the range value to the analyzer.
5. Check the sample flow and ozone flow rates for proper values.
6. Check for disconnected cables to the sensor module.
7. If NO₂ signal is zero while NO signal is correct, check the NO/NO_x valve and the NO₂ converter for proper operation.

12.5.3. UNSTABLE ZERO AND SPAN

Leaks in the 9110T or in the external gas supply and vacuum systems are the most common source of unstable and non-repeatable concentration readings.

1. Check for leaks in the pneumatic systems as described in Section 11.3.12.
2. Consider pneumatic components in the gas delivery system outside the 9110T such as a change in zero air source (ambient air leaking into zero air line or a worn-out zero air scrubber) or a change in the span gas concentration due to zero air or ambient air leaking into the span gas line.
3. Once the instrument passes a leak check, do a flow check (this chapter) to ensure that the instrument is supplied with adequate sample and ozone air.
4. Confirm the sample pressure, sample temperature, and sample flow readings are correct and steady.
5. Verify that the sample filter element is clean and does not need to be replaced.

12.5.4. INABILITY TO SPAN - NO SPAN BUTTON (CAL5)

In general, the 9110T will not display certain buttons whenever the actual value of a parameter is outside of the expected range for that parameter. If the calibration menu does not show a **SPAN** button when carrying out a span calibration, the actual concentration must be outside of the range of the expected span gas concentration, which can have several reasons.

1. Verify that the expected concentration is set properly to the actual span gas concentration in the CONC sub-menu.
2. Confirm that the NO_x span gas source is accurate.
 - This can be done by comparing the source with another calibrated analyzer, or by having the NO_x source verified by an independent traceable photometer.
3. Check for leaks in the pneumatic systems as described in Section 11.3.12.
 - Leaks can dilute the span gas and, hence, the concentration that the analyzer measures may fall short of the expected concentration defined in the CONC sub-menu.
4. If the low-level, hardware calibration has drifted (changed PMT response) or was accidentally altered by the user, a low-level calibration may be necessary to get the analyzer back into its proper range of expected values.
 - One possible indicator of this scenario is a slope or offset value that is outside of its allowed range (0.7-1.3 for slope, -20 to 150 for offsets). See Section 12.8.4 on how to carry out a low-level hardware calibration.

12.5.5. INABILITY TO ZERO - NO ZERO BUTTON (CALZ)

In general, the 9110T will not display certain buttons whenever the actual value of a parameter is outside of the expected range for that parameter. If the calibration menu does not show a **ZERO** button when carrying out a zero calibration, the actual gas concentration must be significantly different from the actual zero point (as per last calibration), which may be for any of several reasons.

1. Confirm that there is a good source of zero air. If the IZS option is installed, compare the zero reading from the IZS zero air source to a zero air source

using NOX-free air. Check any zero air scrubber for performance. It may need to be replaced (Section 11.3.4.2).

2. Check to ensure that there is no ambient air leaking into zero air line. Check for leaks in the pneumatic systems as described in Section 11.3.12.

12.5.6. NON-LINEAR RESPONSE

The 9110T was factory calibrated to a high level of NO and should be linear to within 1% of full scale. Common causes for non-linearity are:

- Leaks in the pneumatic system:
 - Leaks can add a constant of ambient air, zero air or span gas to the current sample gas stream, which may be changing in concentrations as the linearity test is performed.
 - Check for leaks as described in Section 11.3.12.
- The calibration device is in error:
 - Check flow rates and concentrations, particularly when using low concentrations.
 - If a mass flow calibrator is used and the flow is less than 10% of the full scale flow on either flow controller, you may need to purchase lower concentration standards.
- The standard gases may be mislabeled as to type or concentration.
 - Labeled concentrations may be outside the certified tolerance.
- The sample delivery system may be contaminated.
 - Check for dirt in the sample lines or reaction cell.
- Calibration gas source may be contaminated (NO₂ in NO gas is common).
- Dilution air contains sample or span gas.
- Ozone concentration too low because of wet air in the generator.
 - Generator system needs to be cleaned and dried with dry supply air.
 - Check the Perma Pure dryer for leaks.
 - This mostly affects linearity at the low end.
- Ozone stream may be contaminated with impurities.
 - An exhausted ozone cleanser chemical will let compounds such as HNO₃ and ammonia derivatives break through to the reaction cell.
 - Check the contents of the ozone cleanser and replace as necessary (Section 11.3.3).
 - This also will affect linearity mostly at the low level.
- Sample inlet may be contaminated with NOx exhaust from this or other analyzers.

- Verify proper venting of the pump exhaust.
- Span gas overflow is not properly vented and creates a back-pressure on the sample inlet port.
 - Also, if the span gas is not vented at all and does not supply enough sample gas, the analyzer may be evacuating the sample line.
 - Ensure to create and properly vent excess span gas.
- Diffusion of oxygen into Teflon-type tubing over long distances.
 - PTFE or related materials can act as permeation devices. In fact, the permeable membrane of NO₂ permeation tubes is made of PTFE.
 - When using very long supply lines (> 1 m) between high concentrations span gases and the dilution system, oxygen from ambient air can diffuse into the line and react with NO to form NO₂.
- This reaction is dependent on NO concentration and accelerates with increasing NO concentration, hence, affects linearity only at high NO levels.
- Using stainless steel for long span gas supply lines avoids this problem.

12.5.7. DISCREPANCY BETWEEN ANALOG OUTPUT AND DISPLAY

If the concentration reported through the analog outputs does not agree with the value reported on the front panel, you may need to recalibrate the analog outputs.

- This becomes more likely when using a low concentration or low analog output range.
- Analog outputs running at 0.1 V full scale should always be calibrated manually.
- See Section 5.9.3.2 for a detailed description of this procedure.

12.5.8. DISCREPANCY BETWEEN NO AND NOX SLOPES

If the slopes for NO and NO_x are significantly different after software calibration (more than 1%), consider the following three problems:

- NO₂ impurities in the NO calibration gas. NO gases often exhibit NO₂ on the order of 1-2% of the NO value.
 - This will cause differences in the calibration slopes. If the NO₂ impurity in NO is known, it can easily be accounted for by setting the expected values for NO and NO₂ accordingly to different values, e.g., 448 ppb NO and 450 ppb NO_x.
 - This problem is worse if NO gas is stored in a cylinder with balance air instead of balance gas nitrogen or large amounts of nitrous oxide (N₂O).
 - The oxygen in the air slowly reacts with NO to yield NO₂, increasing over time.
- The expected concentrations for NO and NO_x in the calibration menu are set to different values.
 - If a gas with 100% pure NO is used, this would cause a bias.
 - See Section 9.2.3.1 on how to set expected concentration values.

- The converter efficiency parameter has been set to a value not equal to 1.000 even though the conversion efficiency is 1.0.
 - The actual conversion efficiency needs to match the parameter set in the CAL menu.
 - See Section 9.1.4 for more information on this feature.

An instrument calibration with the IZS option (and expected concentrations set to the same amount) will always yield identical slopes for NO and NO_x, as the instrument measures only NO_x and assumes NO to be the same (with NO₂ being zero).

12.6. OTHER PERFORMANCE PROBLEMS

Dynamic problems (i.e. problems that only manifest themselves when the analyzer is monitoring sample gas) can be the most difficult and time consuming to isolate and resolve. The following section provides an itemized list of the most common dynamic problems with recommended troubleshooting checks and corrective actions.

12.6.1. EXCESSIVE NOISE

Excessive noise levels under normal operation usually indicate leaks in the sample supply or the analyzer itself. Ensure that the sample or span gas supply is leak-free and carry out a detailed leak check as described earlier in this chapter.

Another possibility of excessive signal noise may be the preamplifier board, the high voltage power supply and/or the PMT detector itself.

- Contact the factory on troubleshooting these components.

12.6.2. SLOW RESPONSE

If the analyzer starts responding too slow to any changes in sample, zero or span gas, check for the following:

- Dirty or plugged sample filter or sample lines.
- Sample inlet line is too long.
- Leaking NO/NO_x valve. Carry out a leak check.
- Dirty or plugged critical flow orifices. Check flows, pressures and, if necessary, change orifices (Section 11.3.10).
- Wrong materials in contact with sample - use glass, stainless steel or Teflon materials only. Porous materials, in particular, will cause memory effects and slow changes in response.
- Dirty reaction cell. Clean the reaction cell.
- Insufficient time allowed for purging of lines upstream of the analyzer. Wait until stability is low.
- Insufficient time allowed for NO or NO₂ calibration gas source to become stable. Wait until stability is low.
- NO₂ converter temperature is too low. Check for proper temperature.

12.6.3. AUTO ZERO WARNINGS

Auto Zero warnings occur if the signal measured during an Auto Zero cycle is higher than 200 mV.

Note

The Auto-Zero warning displays the value of the Auto Zero reading when the warning occurs.

- If this value is higher than 150 mV, check that the Auto Zero valve is operating properly.
 - To do so, use the **SIGNAL I/O** functions in the **DIAG** menu to toggle the valve on and off.
 - Listen if the valve is switching, see if the respective LED on the relay board is indicating functionality.
- Scroll the **TST** functions until **PMT** is displayed and observe the PMT value change between the two valve states.
 - If the valve is operating properly, you should be able to hear it switch (once a minute under normal operation or when manually activated from the **SIGNAL I/O** menu):
 - the PMT value should drop from span gas reading (e.g., 800-900 mV at 400 ppb NO) to less than 150 mV and;
 - the LED on the relay board should light up when the valve is activated.
 - If the PMT value drops significantly but not to less than 150 mV, the valve is probably leaking across its ports.
 - In this case, replace the valve.
 - If the PMT value does not change at all, the valve is probably not switching at all.
 - Check the power supply to the valve (12 V to the valve should turn on and off when measured with a voltmeter).

Note

It takes only a small leak across the ports of the valve to show excessive Auto Zero values when supplying high concentrations of span gas.

Another reason for high (although not necessarily out-of-range) values for Auto Zero could be the ozone air filter cartridge, if its contents have been exhausted and needs to be replaced.

- This filter cartridge chemicals that can cause chemiluminescence and, if saturated, these chemicals can break through to the reaction cell, causing an erroneously high Auto Zero value (background noise).

A dirty reaction cell can cause high Auto Zero values.

- Clean the reaction cell according to Section 11.3.9.

Finally, a high **HVPS** voltage value may cause excess background noise and a high **AZERO** value.

- The HVPS value changes from analyzer to analyzer and could show nominal values between 450 and 800 V.
- Check the low-level hardware calibration of the preamplifier board and, if necessary, recalibrate exactly as described in Section 12.8.4 in order to minimize the **HVPS**.

12.7. SUBSYSTEM CHECKOUT

The preceding sections of this manual discussed a variety of methods for identifying possible sources of failures or performance problems within the analyzer. In most cases this included a list of possible causes and, in some cases, quick solutions or at least a pointer to the appropriate sections describing them. This section describes how to determine if a certain component or subsystem is actually the cause of the problem being investigated.

12.7.1. AC MAIN POWER

The 9110T analyzer's electronic systems will operate with any of the specified power regimes. As long as system is connected to 100-120 VAC or 220-240 VAC at either 50 or 60 Hz it will turn on and after about 30 seconds show a front panel display.

- Internally, the status LEDs located on the Relay PCA, Motherboard and CPU should turn on as soon as the power is supplied.
- If they do not, check the circuit breaker built into the ON/OFF switch on the instruments front panel.
- If the instrument is equipped with an internal pump, it will begin to run. If it does not:
 - Verify that the pump power configuration plug is properly wired (see Section 13.7.1.1 and Figure 13-27)
 - If the configuration plug is set for 230 VAC and the instrument is plugged into 115 VAC or 100 VAC the sample pump will not start.
- If the configuration plug is set for 115 or 100 VAC and the unit is plugged into a 230 VAC circuit, the circuit breaker built into the ON/OFF Switch on the front panel will trip to the OFF position immediately after power is switched on.
- 9110T's without internal pumps that are configured for 230 V will still turn on at 115 V, but the heaters may burn out or not heat up fast enough.



WARNING – ELECTRICAL SHOCK HAZARD

Should the AC power circuit breaker trip, investigate and correct the condition causing this situation before turning the analyzer back on.

12.7.2. DC POWER SUPPLY

If you have determined that the analyzer's AC mains power is working, but the unit is still not operating properly, there may be a problem with one of the instrument's switching power supplies. The supplies can have two faults, namely no DC output, and noisy output.

To assist tracing DC Power Supply problems, the wiring used to connect the various printed circuit assemblies and DC Powered components and the associated test points on the relay PCA follow a standard color-coding scheme as defined in the following table.

Table 12-6: DC Power Test Point and Wiring Color Codes

NAME	TEST POINT#	COLOR	DEFINITION
DGND	1	Black	Digital ground
+5V	2	Red	
AGND	3	Green	Analog ground
+15V	4	Blue	
-15V	5	Yellow	
+12R	6	Purple	12 V return (ground) line
+12V	7	Orange	

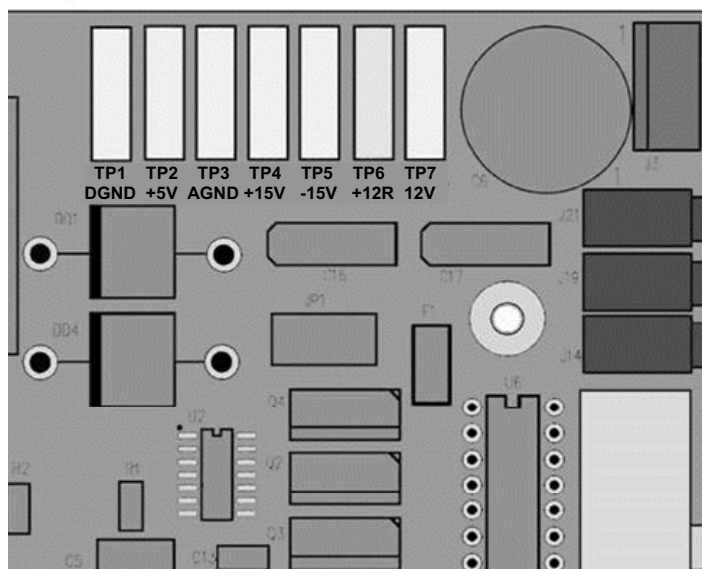

Figure 12-4: Location of DC Power Test Points on Relay PCA

A voltmeter should be used to verify that the DC voltages are correct per the values in the table below, and an oscilloscope, in AC mode, with band limiting turned on, can be used to evaluate if the supplies are producing excessive noise (> 100 mV p-p).

Table 12-7: DC Power Supply Acceptable Levels

POWER SUPPLY	VOLTAGE	CHECK RELAY BOARD TEST POINTS				MIN V	MAX V
		FROM Test Point		TO Test Point			
		NAME	#	NAME	#		
PS1	+5	DGND	1	+5	2	+4.85	+5.25
PS1	+15	AGND	3	+15	4	+13.5	+16.0
PS1	-15	AGND	3	-15V	5	-13.5	-16.0
PS1	AGND	AGND	3	DGND	1	-0.05	+0.05
PS1	Chassis	DGND	1	Chassis	N/A	-0.05	+0.05
PS2	+12	+12V Ret	6	+12V	7	+11.8	+12.5
PS2	DGND	+12V Ret	6	DGND	1	-0.05	+0.05

12.7.3. I²C BUS

Operation of the I²C bus can be verified by observing the behavior of D1 on the relay PCA & D2 on the Valve Driver PCA. Assuming that the DC power supplies are operating properly, the I²C bus is operating properly if D1 on the relay PCA and D2 of the Valve Driver PCA are flashing

There is a problem with the I²C bus if both D1 on the relay PCA and D2 of the Valve Driver PCA are ON/OFF constantly.

12.7.4. LCD/DISPLAY MODULE

TOUCHSCREEN INTERFACE

Assuming that there are no wiring problems and that the DC power supplies are operating properly, the display screen should light and show the splash screen and other indications of its state as the CPU goes through its initialization process.

12.7.5. RELAY PCA

The Relay PCA can be most easily checked by observing the condition of the status LEDs on the Relay PCA (see Section 12.3.2), and using the **SIGNAL I/O** submenu under the **DIAG** menu (see Section 12.1.3) to toggle each LED **ON** or **OFF**.

If D1 on the Relay PCA is flashing and the status indicator for the output in question (Heater power, Valve Drive, etc.) toggles properly using the Signal I/O function, then the associated control device on the Relay PCA is bad.

Several of the control devices are in sockets and can be easily replaced. The following table lists the control device associated with a particular function:

Table 12-8: Relay PCA Control Devices

FUNCTION	CONTROL DEVICE	SOCKETED
All valves	U5	Yes
Reaction Cell Heater	K1	Yes
NO ₂ → NO Converter heater	K2	Yes
Permeation Tube Heater for Optional Internal Span Gas Generator	K4	Yes

12.7.6. MOTHERBOARD

12.7.6.1. Test Channel / Analog Outputs Voltage

The **ANALOG OUTPUT** submenu, located under the **SETUP → MORE → DIAG** menu is used to verify that the 9110T analyzer's three analog outputs are working properly. The test generates a signal on all three outputs simultaneously as shown in the following table:

Table 12-9: Analog Output Test Function - Nominal Values Voltage Outputs

		FULL SCALE OUTPUT OF VOLTAGE RANGE (see Section 5.9.3.1)			
		100MV	1V	5V	10V*
STEP	%	NOMINAL OUTPUT VOLTAGE			
1	0	0	0	0	0
2	20	20 mV	0.2	1	2
3	40	40 mV	0.4	2	4
4	60	60 mV	0.6	3	6
5	80	80 mV	0.8	4	8
6	100	100 mV	1.0	5	10

* For 10V output, increase the Analog Output Calibration Limits (AOUT CAL LIM in the DIAG>Analog I/O Config menu) to 4% (offset limit) and 20% (slope limit).

For each of the steps the output should be within 1% of the nominal value listed except for the 0% step, which should be within 0mV ±2 to 3 mV. Ensure you take into account any offset that may have been programmed into channel (See Section 5.9.3.9).

If one or more of the steps fails to be within these ranges, it is likely that there has been a failure of the either or both of the Digital-to-Analog Converters (DACs) and their associated circuitry on the motherboard. To perform the test connect a voltmeter to the output in question and perform an analog output step test as follows:

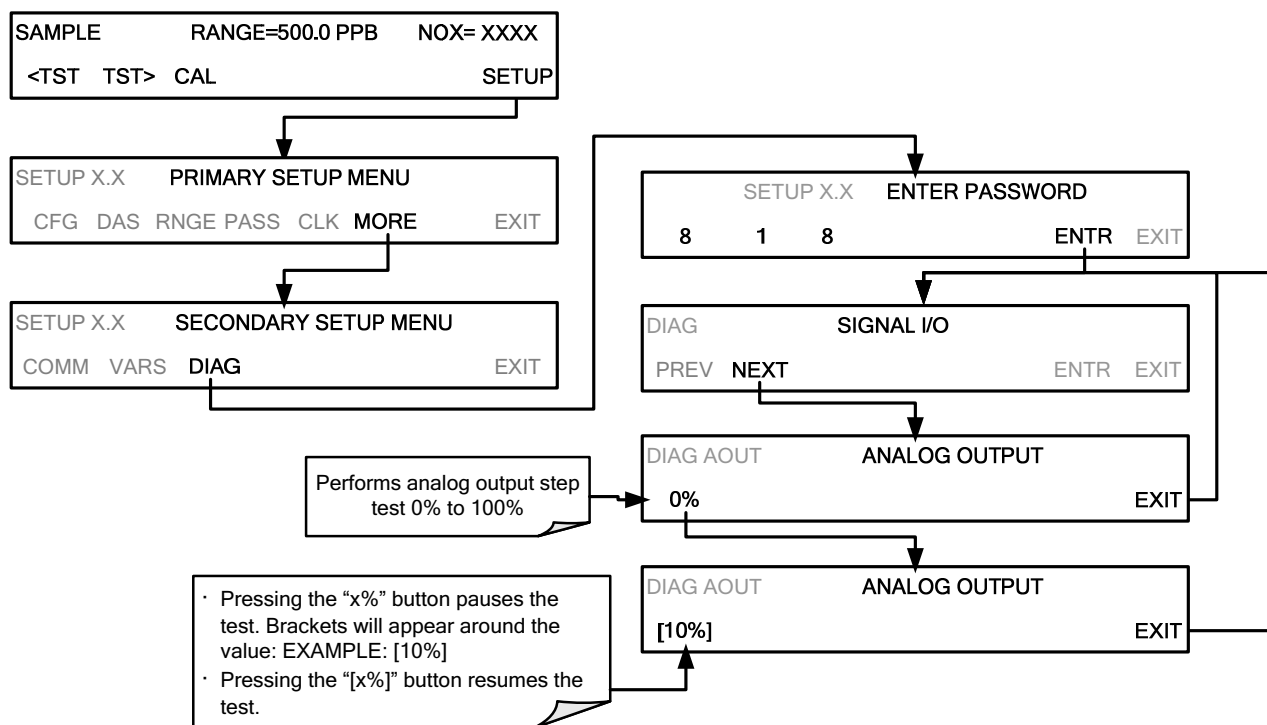

12.7.6.2. A/D Functions

The simplest method to check the operation of the A-to-D converter on the motherboard is to use the Signal I/O function under the **DIAG** menu to check the two A/D reference voltages and input signals that can be easily measured with a voltmeter.

1. Use the Signal I/O function (see Section 12.1.3 and Appendix A) to view the value of **REF_4096_MV** and **REF_GND**.
 - If both are within 3 mV of nominal (4096 and 0), and are stable, ± 0.2 mV then the basic A/D is functioning properly. If not then the motherboard is bad.
2. Choose a parameter in the Signal I/O function list (see Section 12.1.3) such as **OZONE_FLOW** .
 - Compare this voltages at its origin (see the interconnect drawing and interconnect list in Appendix D) with the voltage displayed through the signal I/O function.
 - If the wiring is intact but there is a large difference between the measured and displayed voltage (± 10 mV) then the motherboard is bad.

12.7.6.3. Status Outputs

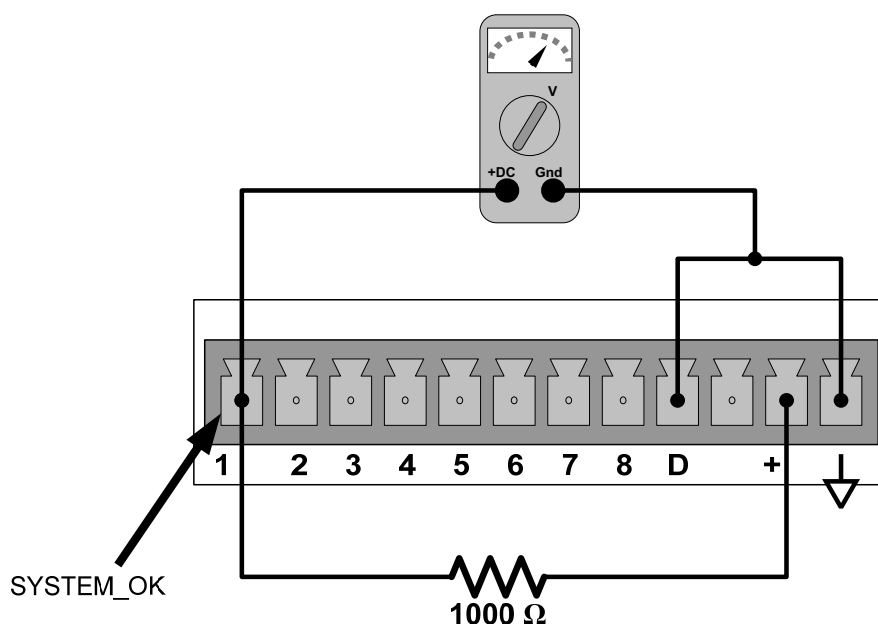

Figure 12-5: Typical Set Up of Status Output Test

To test the status output electronics:

1. Connect a jumper between the “D” pin and the “∇” pin on the status output connector.
2. Connect a 1000 ohm resistor between the “+” pin and the pin for the status output that is being tested.
3. Connect a voltmeter between the “∇” pin and the pin of the output being tested.
4. Under the DIAG → Signal I/O menu (see Section 12.1.3), scroll through the inputs and outputs until you get to the output in question.

5. Alternately, turn on and off the output noting the voltage on the voltmeter.
 - It should vary between 0 volts for ON and 5 volts for OFF.

Table 12-10: Status Outputs Check

PIN (LEFT TO RIGHT)	STATUS
1	ST_SYSTEM_OK
2	ST_CONC_VALID
3	ST_HIGH_RANGE
4	ST_ZERO_CAL
5	ST_SPAN_CAL
6	ST_DIAG_MODE
7	<i>Not Used on 9110T</i>
8	ST_O2_CAL

12.7.6.4. Control Inputs

The control input bits can be tested by applying a trigger voltage to an input and watching changes in the status of the associated function under the **SIGNAL I/O** submenu:

EXAMPLE: to test the “A” control input:

1. Under the **DIAG** → Signal I/O menu (see Section 12.1.3), scroll through the inputs and outputs until you get to the output named **EXT_ZERO_CAL**.
2. Connect a jumper from the “+” pin on the appropriate connector to the “U” on the same connector.
3. Connect a second jumper from the “∇” pin on the connector to the “A” pin.
4. The status of EXT_ZERO_CAL should change to read “ON”.
5. Connect a second jumper from the “∇” pin on the connector to the “B” pin.
6. The status of EXT_ZERO_CAL should change to read “ON”.

Table 12-11: 9110T Control Input Pin Assignments and Corresponding Signal I/O Functions

INPUT	CORRESPONDING I/O SIGNAL
A	EXT_ZERO_CAL
B	EXT_SPAN_CAL1
C, D, E & F	NOT USED

12.7.7. PRESSURE / FLOW SENSOR ASSEMBLY

The flow and pressure sensors of the 9110T are located on a PCA just behind the PMT sensor (see Figure 3-5) can be checked with a Voltmeter.

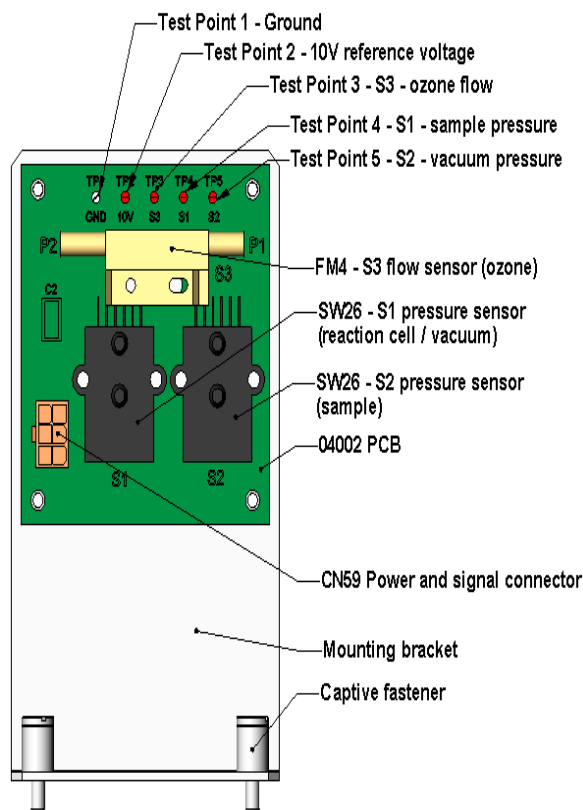

Figure 12-6: Pressure / Flow Sensor Assembly

The following procedure assumes that the wiring is intact and that the motherboard and power supplies are operating properly:

12.7.7.1. Basic PCA Operation Check:

- Measure the voltage between TP2 and TP1 C1 it should be 10 VDC ± 0.25 VDC. If not then the board is bad. Replace the PCA.

12.7.7.2. Sample Pressure Sensor Check:

1. Measure the pressure on the inlet side of S1 with an external pressure meter.
2. Measure the voltage across TP4 and TP1.
 - The expected value for this signal should be:

$$\text{Expected mVDC} = \left(\frac{\text{Pressure}}{30.0_{\text{Hg-In-A}}} \times 4660_{\text{mVDC}} \right) + 250_{\text{mVDC}} \quad \pm 10\%_{\text{rdg}}$$

EXAMPLE: If the measured pressure is 20 Hg-in-A, the expected voltage level between TP4 and TP1 would be between 2870 mVDC and 3510 mVDC.

EXAMPLE: If the measured pressure is 25 Hg-in-A, the expected voltage level between TP4 and TP1 would be between 3533 mVDC and 4318 mVDC.

- If this voltage is out of range, then either pressure transducer S1 is bad, the board is bad or there is a pneumatic failure preventing the pressure transducer from sensing the absorption cell pressure properly. Replace the PCA.

12.7.7.3. Vacuum Pressure Sensor Check

- Measure the pressure on the inlet side of S2 with an external pressure meter.
- Measure the voltage across TP5 and TP1.
 - Evaluate the reading in the same manner as for the sample pressure sensor.

12.7.7.4. O₃ Flow Sensor Check

- Measure the voltage across TP3 and TP1.
 - With proper flow (80 cc³/min through the O₃ generator), this should be approximately 2V ± 0.25 (this voltage will vary with altitude).
 - With flow stopped (photometer inlet disconnected or pump turned OFF) the voltage should be approximately 1V.
 - If the voltage is incorrect, the flow sensor S3 is bad, the board is bad (replace the PCA) or there is a leak upstream of the sensor.

12.7.8. CPU

There are two major types of CPU board failures, a complete failure and a failure associated with the Disk On Module (DOM). If either of these failures occurs, contact the factory.

For complete failures, assuming that the power supplies are operating properly and the wiring is intact, the CPU is faulty if on power-on, the watchdog LED on the motherboard is not flashing.

- In some rare circumstances, this failure may be caused by a bad IC on the motherboard, specifically U57, the large, 44 pin device on the lower right hand side of the board. If this is true, removing U57 from its socket will allow the instrument to start up but the measurements will be invalid.
- If the analyzer stops during initialization (the front panel display shows a fault or warning message), it is likely that the DOM, the firmware or the configuration and data files have been corrupted.

12.7.9. RS-232 COMMUNICATIONS

12.7.9.1. General RS-232 Troubleshooting

TAI's analyzers use the RS-232 communications protocol to allow the instrument to be connected to a variety of computer-based equipment. RS-232 has been used for many years and as equipment has become more advanced, connections between various types of hardware have become increasingly difficult. Generally, every manufacturer observes the signal and timing requirements of the protocol very carefully.

Problems with RS-232 connections usually center around 4 general areas:

- Incorrect cabling and connectors. See Section 3.3.1.8, Figure 3-13 for connector and pin-out information.
- The BAUD rate and protocol are incorrectly configured. See Section 6.2.2.
- If a modem is being used, additional configuration and wiring rules must be observed. See Section 8.3
- Incorrect setting of the DTE – DCE Switch. See Section 6.1 to set correctly.
- Verify that cable (P/N 03596) that connects the serial COMM ports of the CPU to J12 of the motherboard is properly seated.

12.7.9.2. Troubleshooting Analyzer/Modem or Terminal Operation

These are the general steps for troubleshooting problems with a modem connected to a Teledyne analyzer.

1. Check cables for proper connection to the modem, terminal or computer.
2. Check to ensure that the DTE-DCE is in the correct position as described in Section 6.1.
3. Check to ensure that the set up command is correct (see Section 8.3).
4. Verify that the Ready to Send (RTS) signal is at logic high. The 9110T sets pin 7 (RTS) to greater than 3 volts to enable modem transmission.
5. Ensure that the BAUD rate, word length, and stop bit settings between modem and analyzer match. See Section 6.2.2.
6. Use the RS-232 test function to send “w” characters to the modem, terminal or computer. See Section 6.2.3.
7. Get your terminal, modem or computer to transmit data to the analyzer (holding down the space bar is one way); the green LED should flicker as the instrument is receiving data.
8. Ensure that the communications software or terminal emulation software is functioning properly.

Note

Further help with serial communications is available in a separate manual “RS-232 Programming Notes” TAI P/N 01350.

12.7.10. NO₂ → NO CONVERTER

Provided that oxygen was present in the Sample stream during operation for the NO₂ converter to function properly, the NO₂ converter assembly can fail in two ways:

- An electrical failure of the band heater and/or the thermocouple control circuit and;

- A performance failure of the converter itself.

12.7.10.1. NO₂ → NO Converter Electrical System

NO₂ converter heater failures can be divided into two possible problems:

- Temperature is reported properly but heater does not heat to full temperature.
 - In this case, the heater is either disconnected or broken or the power relay is broken.
 - Disconnect the heater cable coming from the relay board and measure the resistance between any two of the three heater leads with a multi-meter.
 - The resistance between A and B should be about 1000 Ω.
 - That between A and C should be the same as between B and C, about 500 Ω each.
 - If any of these resistances is near zero or without continuity, the heater is broken.
- Temperature reports zero or overload (near 500° C).
 - This indicates a disconnected or failing thermocouple or a failure of the thermocouple circuit.
 - Check that the thermocouple is connected properly and the wire does not show signs of a broken or kinked pathway.
 - If it appears to be properly connected, disconnect the yellow thermocouple plug (marked K) from the relay board and measure the voltage (not resistance) between the two leads with a multi-meter capable of measuring in the low mV range.
 - The voltage should be about 12 mV (ignore the sign) at 315° C and about 0 mV at room temperature.
- Measure the continuity with an Ohm-meter.
 - It should read close to zero Ω. If the thermo-couple does not have continuity, it is broken.
 - If it reads zero voltage at elevated temperatures, it is broken.
- To test the thermocouple at room temperature, heat up the converter can (e.g., with a heat gun) and see if the voltage across the thermocouple leads changes.
 - If the thermocouple is working properly, the electronic circuit is broken.

ATTENTION

COULD DAMAGE INSTRUMENT AND VOID WARRANTY

If the thermocouple is broken, do NOT replace the thermocouple without first consulting the factory; using the wrong Type could cause permanent damage to the instrument. The Type K thermocouple has a red and a yellow wire. If in doubt, consult the factory.

12.7.10.2. NO₂ Conversion Efficiency

The efficiency at which the NO₂ → NO converter changes NO₂ into NO directly effects the accuracy of the 9110T's NO_x, NO and NO₂ measurements. The 9110T firmware includes a Converter Efficiency (CE) gain factor that is multiplied by the NO₂ and NO_x measurements to calculate the final concentrations for each. This gain factor is stored in the analyzer's memory.

The default setting for the NO₂ converter efficiency is 1.0000. Over time, the molybdenum in the NO₂ → NO converter oxidizes and it becomes less efficient at converting NO₂ into NO.

To ensure accurate operation of the 9110T, it is important to check the NO₂ conversion efficiency periodically and to update this value as necessary.

- For the analyzer to function correctly, the converter efficiency must be between 0.9600 and 1.0200 (96-102% conversion efficiency) as per US-EPA requirements.
- If the converter's efficiency is outside these limits, the NO₂ converter should be replaced.
- The current converter efficiency level is also recorded along with the calibration data in the DAS for documentation and performance analysis (Section 7).

12.7.10.3. Calculating / Checking Converter Efficiency

The 9110T to automatically calculate the current NO₂ conversion efficiency by comparing a known starting concentration of NO₂ gas to the measured NO output of the converter. There are three steps to performing this operation.

Step 1:

Supply the analyzer with a known concentration of NO₂ gas, to the analyzer.

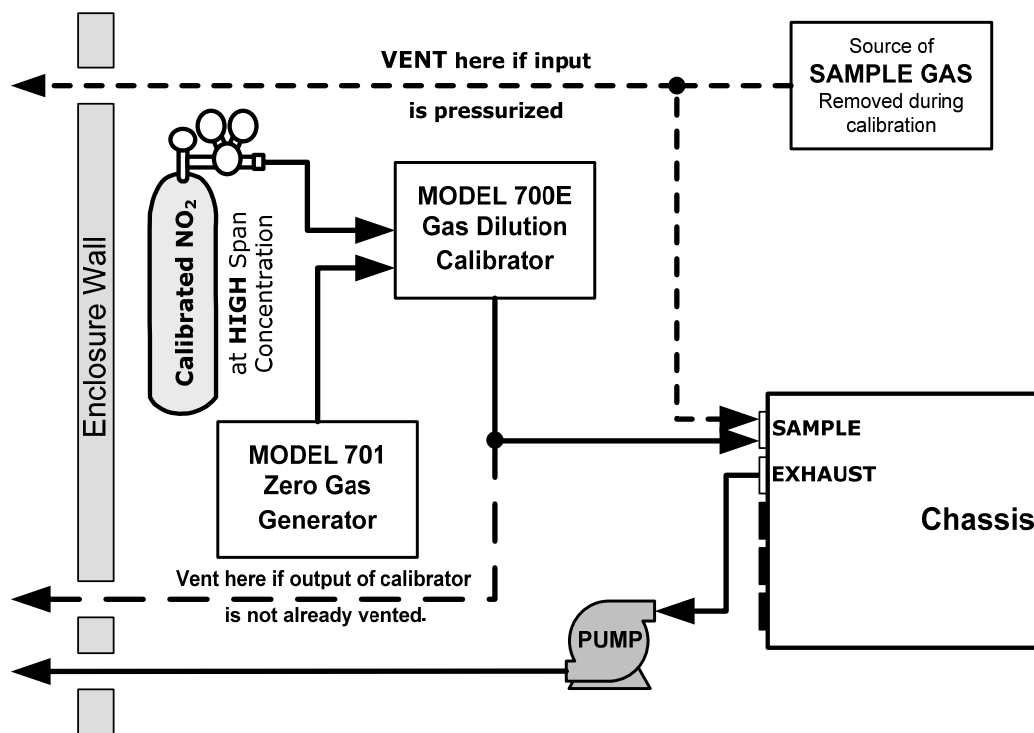
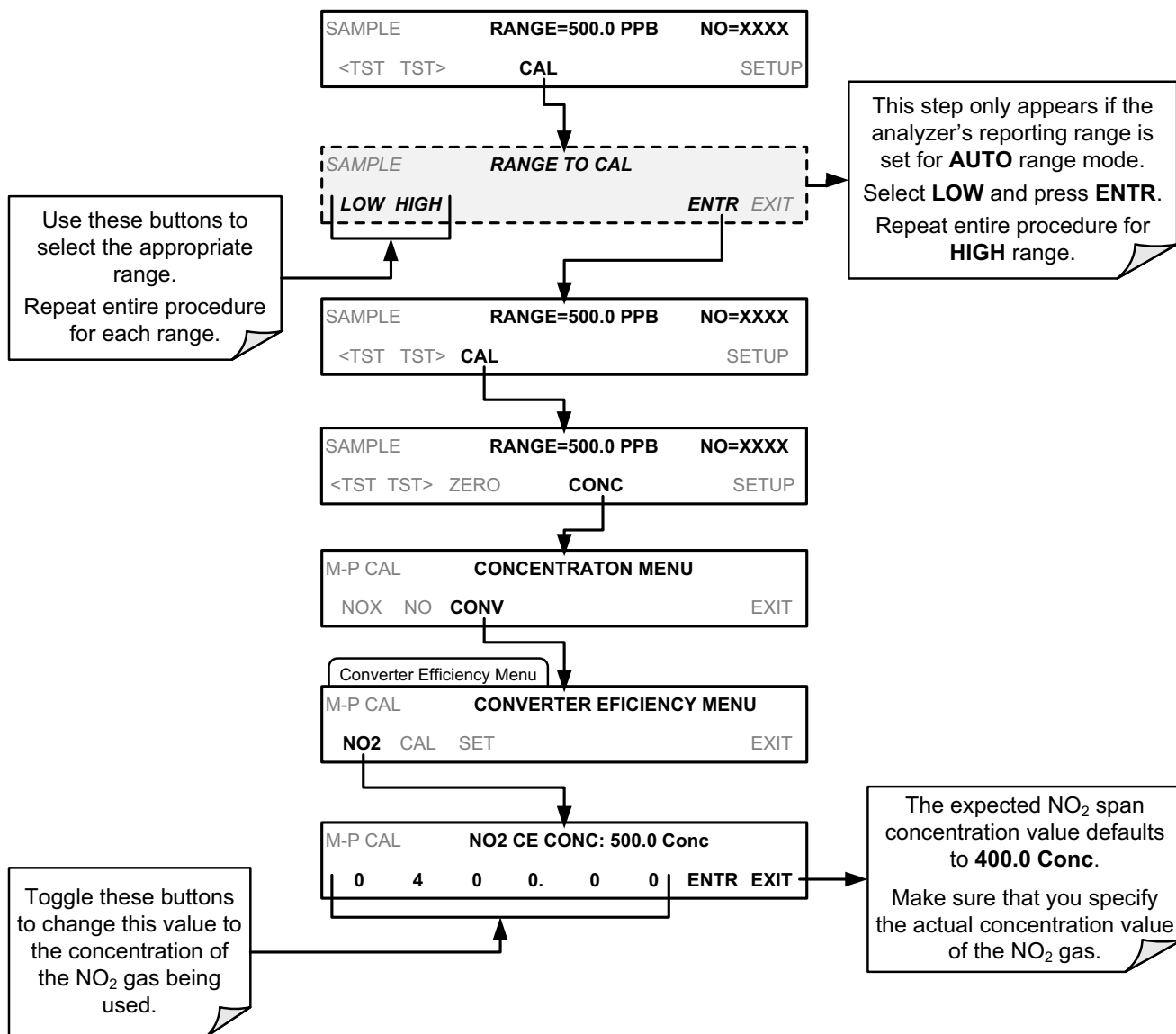

Figure 12-7: Setup for determining NO₂ → NO Efficiency – 9110T Base Configuration

Step 2:

Input the starting NO₂ concentration value into the 9110T by pressing:



STEP 3:

To cause the analyzer to calculate and record the NO₂ → NO converter efficiency, press:

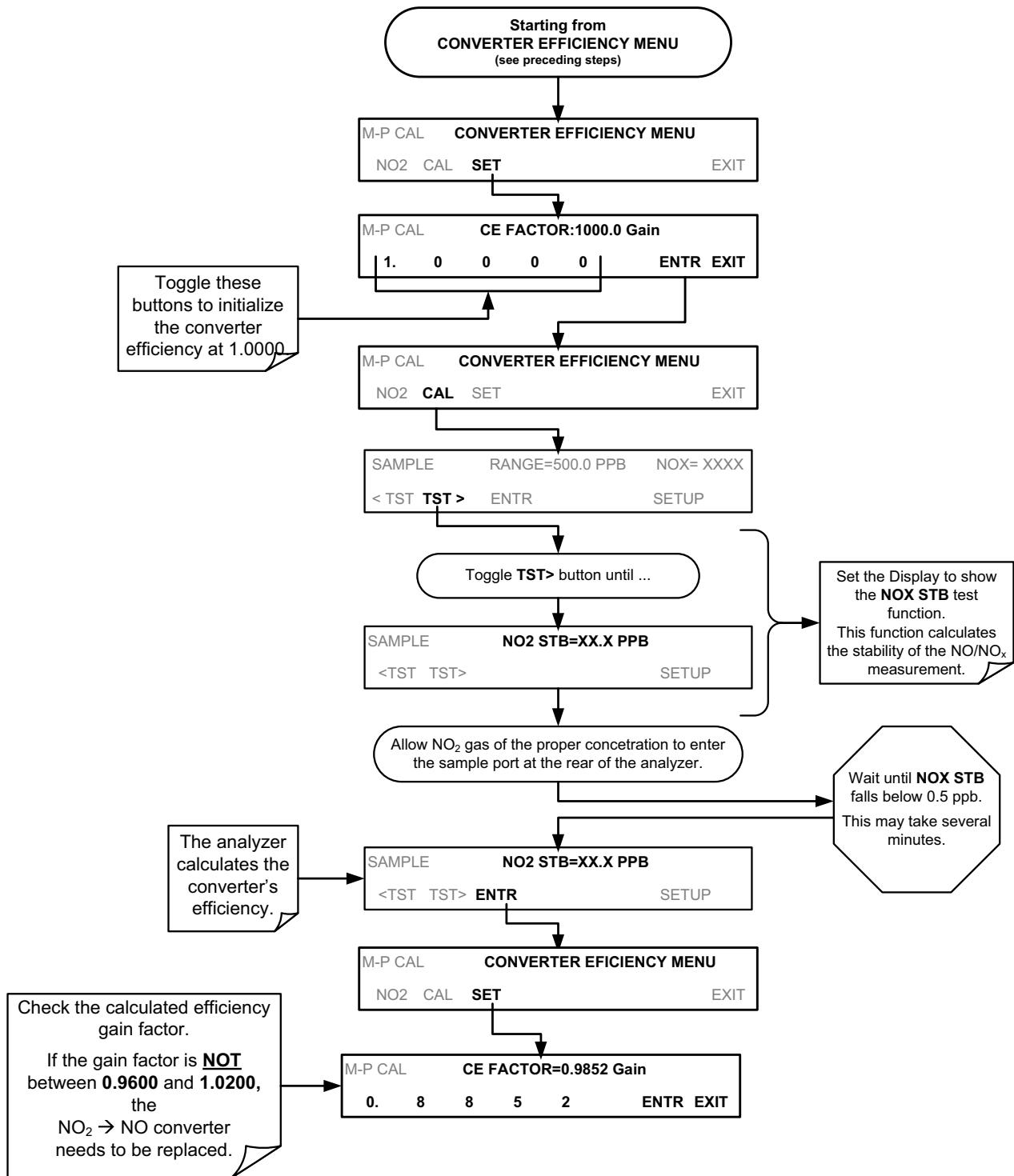

12.7.10.4. Evaluating NO₂ → NO Converter Performance

If the converter appears to have performance problems (conversion efficiency is outside of allowed range of 96-102%), check the following:

- Recalculate the converter efficiency (see previous section)
- Accuracy of NO₂ source (GPT or gas tank standard).
 - NO₂ gas standards are typically certified to only $\pm 2\%$ and often change in concentrations over time. You should get the standard re-certified every year.
 - If you use the GPT calibration, check the accuracy of the ozone source.
- Age of the converter.
 - The NO₂ converter has a limited operating life and may need to be replaced every ~3 years or when necessary (e.g., earlier if used with continuously high NO₂ concentrations).
 - We estimate a lifetime of about 10000 ppm-hours (a cumulative product of the NO₂ concentration times the exposure time to that concentration).
 - This lifetime heavily depends on many factors such as:
 - Absolute concentration (temporary or permanent poisoning of the converter is possible).
 - Sample flow rate and pressure inside the converter.
 - Converter temperature.
 - Duty cycle.
 - This lifetime is only an estimated reference and not a guaranteed lifetime.
- In some cases with excessive sample moisture, the oxidized molybdenum metal chips inside the converter cartridge may bake together over time and restrict air flow through the converter, in which case it needs to be replaced.
 - To avoid this problem, we recommend the use of a sample gas conditioner (Section 3.3.2.6).
 - Section 11.3.8 describes how to replace the NO₂ converter cartridge.
- With no NO₂ in the sample gas and a properly calibrated analyzer, the NO reading is negative, while the NO₂ reading remains around zero.
- The converter is destroying NO and needs to be replaced.
- With no NO₂ in the sample gas and a properly calibrated analyzer, the NO_x reading is significantly higher than the actual (gas standard) NO concentration.
- The converter is producing NO₂ and needs to be replaced.

12.7.11. SIMPLIFIED GPT CALIBRATION

This section describes how to determine the NO₂ → NO converter's efficiency using a GPT method where the actual concentration of ozone is not a factor in the accuracy of the calculation.

- This procedure is based on the Code of Federal Regulations, Title 40, Chapter I, subchapter C, Part 50, Appendix F.

- In the following example a reference point of 450 ppb NO gas will be used. This is only an example. Any other reference points within measurement range of the instrument may be used.
- For this procedure use a calibrated O₃ generator, such as a Teledyne T700.

Note

There must be a minimum of 10% more NO than O₃ produced.

Example, if the Ozone concentration used is 400 ppb then the NO concentration must be used must be 440 ppb or more.

PART 1: PREPARATION

1. Leak check machine to ensure that there are no leaks in the analyzer.
2. Calibrate the instrument at the same NO span gas value as being used in this method.
 - For this example 450 ppb NO span gas
3. If you have input a converter efficiency (CE) factor into the instrument firmware (see 12.7.10.3) other than 100%, change this back to 100% for the duration of this test. (CAL>CONC>CONV>SET).

PART 2: DETERMINE THE AMOUNT OF NO OUTGASSED BY THE NO₂ → NO CONVERTER.

4. Bypass the NO₂ → NO converter by placing a short piece of tubing in the gas stream in place of the converter.
 5. Perform a straight dilution with 445 ppb NO gas & air as a diluent gas.
 6. Input the NO gas into the analyzer.
 7. Allow the machine to stabilize & write down the NO_x value on line 2 of GPT data sheet (Section 12.7.11.1).
 8. Remove the converter bypass so that the NO gas is flowing through the NO₂ → NO converter
 9. Allow the machine to stabilize.
 10. Write down your NO_x value on your data sheet on lines 3 AND line 5 of the GPT data sheet.
 11. Subtract line 2 from line 3 & write that number down on line 4. Also write the NO value on line 8 of the data sheet.
- The specification shown on the data sheet is the value that is used by TAI when performing the procedure on new NO₂ → NO converters.
 - Older NO₂ → NO converters might outgas a bit more NO, therefore a slightly wider specification might be in order.
 - If this value is a constant or changes only slightly over time, this is not a problem the machine will calibrate this out.

PART 3: PERFORM THE SIMPLIFIED GPT CALCULATION.

12. Generate the same 450 ppb NO gas & input 400 ppb of O₃ (or generate 450 ppb NO & 400 ppb NO₂, if that's what your calibrator says).
13. Allow the instrument to stabilize for 10 minutes.
14. Write down the NO_x value on line 6 & the NO value on line 9.
15. Subtract line 6 from line 6 & put that onto line 7.
16. Subtract line 8 from line 7 & put that onto line 10.
17. Write the number from line 7 into the blank next to letter A on line 11 & put the number from line 10 into the blank next to letter B on line 11.
18. Divide A by B & multiply it by 100.
19. Write this value it into the blank next to letter C on lines 11 and 12.
20. Subtract that value from 100 & write it in the blank next to the letter D on line 12.
21. This is the converter efficiency.
 - This value should be >96%.
 - For CEMS applications, a converter efficiency of <96% might be acceptable, depending on application & the guideline set up by the regulatory agency.
 - In any application, check with your regulatory agency (agencies) to see what the minimum CE factor is before replacing the converter.

12.7.11.1. Simplified GPT Data Sheet

Line # TEST	RESULT
1 LEAK-CHECK (WHEN HOT)	YES / NO
2 NO _x RESPONSE (MOLY BYPASSED)	_____
3 NO _x RESPONSE (MOLY IN-LINE)	_____
4 OUT-GASSING (NO – NOX)	_____ (>-5 ppb, <5 ppb)
5 (NO _x ORIG) (NO _x mode, O ₃ off)	_____ ppb
6 (NO _x REM) (NO _x mode, O ₃ on)	_____ ppb
7 NO _x LOSS	_____ (A) (<4% of NO _x ORIG: for 450PP 4% is 18 ppb)
8 (NO ORIG) (NO mode, O3 off)	_____ ppb
9 (NO REM) (NO mode, O3 on)	_____ ppb
10 NO ₂	_____ (B) (>300ppb)
11 Efficiency LOSS [(A / B) x 100] = [(_____ A / _____ B) x 100] = _____ C %	
12 Total Conv Eff [100% – C] = 100% - _____ C = _____ D % (> 96%)	

12.7.12. PHOTOMULTIPLIER TUBE (PMT) SENSOR MODULE

The PMT detects the light emitted by the reaction of NO with ozone. It has a gain of about 500000 to 1000000. It is not possible to test the detector outside of the instrument in the field. The basic method to diagnose a PMT fault is to eliminate the other components using ETEST, OTEST and specific tests for other sub-assemblies.

12.7.12.1. Optic Test

The optic test function tests the response of the PMT sensor by turning on an LED located in the cooling block of the PMT (see Figure 13-20). The analyzer uses the light emitted from the LED to test its photo-electronic subsystem, including the PMT and the current to voltage converter on the pre-amplifier board.

- To ensure that the analyzer measures only the light coming from the LED, the analyzer should be supplied with zero air.
- The optic test should produce a PMT signal of about 2000±1000 mV.

To activate the optics test, press:

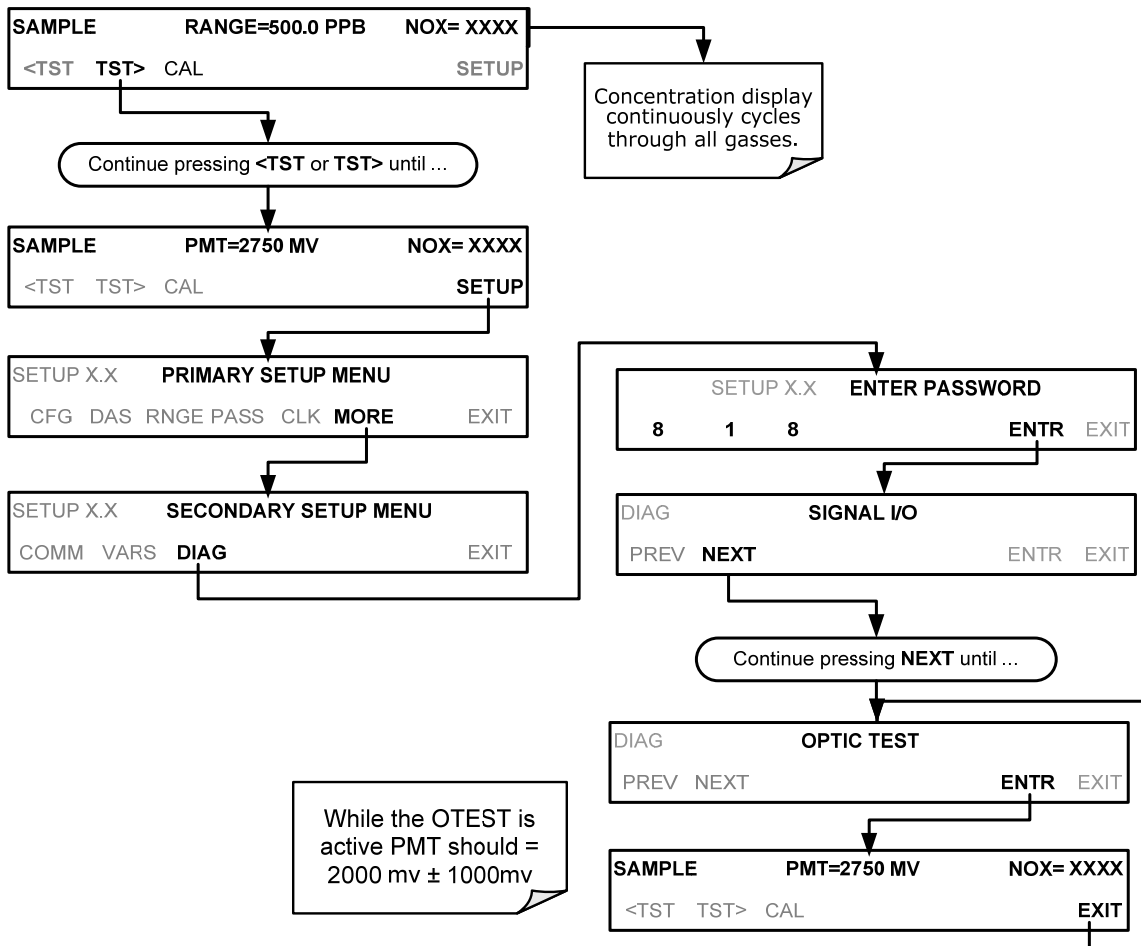

Note

This is a coarse test for functionality and not an accurate calibration tool. The resulting PMT signal can vary significantly over time and also changes with low-level calibration.

12.7.12.2. Electrical Test

The electrical test function creates a current, which is substituted for the PMT signal and feeds it into the preamplifier board.

- This signal is generated by circuitry on the pre-amplifier board itself and tests the filtering and amplification functions of that assembly along with the A/D converter on the motherboard.
- It does not test the PMT itself.
- The electrical test should produce a PMT signal of about 2000 ±1000 mV.

To activate the electrical test, press:

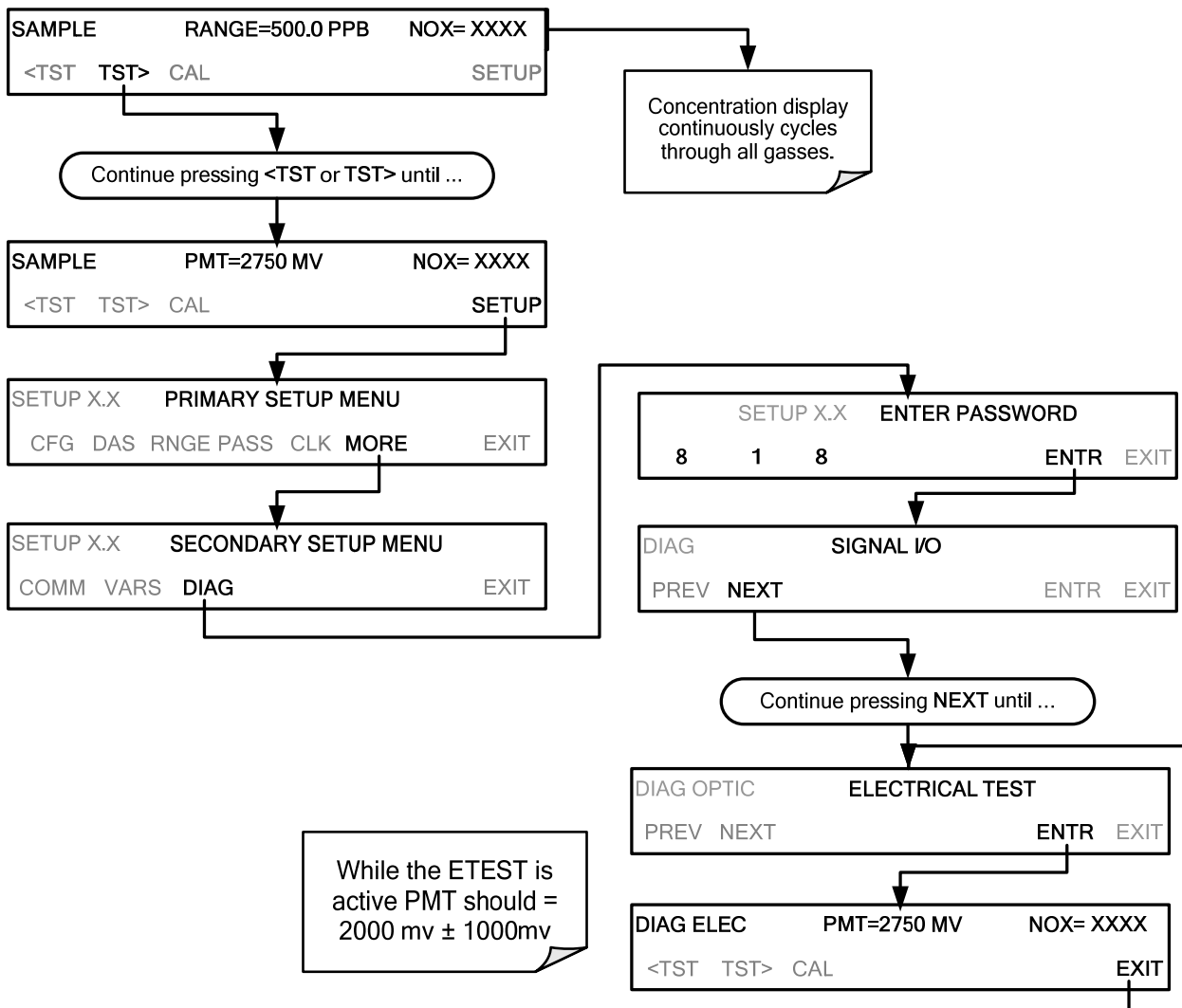

12.7.13. PMT PREAMPLIFIER BOARD

To check the correct operation of the preamplifier board, perform an the optics test (OTEST) and an electrical test (ETEST) described in Sections 12.7.12.1 and 12.7.12.2 above.

- If the instrument passes the OTEST but fails the ETEST, the preamplifier board may be faulty or need a hardware calibration.

12.7.13.1. High Voltage Power Supply

The HVPS is located in the interior of the sensor module and is plugged into the PMT tube. It requires 2 voltage inputs.

- The first is +15 V, which powers the supply.
- The second is the programming voltage which is generated on the preamplifier board.
- Adjustment of the HVPS is covered in the factory calibration procedure in Section 12.8.4.

This power supply has 10 independent power supply steps, one to each pin of the PMT. The following test procedure below allows you to test each step.

1. Turn off the instrument.
2. Remove the cover and disconnect the 2 connectors at the front of the NOX sensor module.
3. Remove the end cap from the sensor (4 screws).
4. Remove the HVPS/PMT assembly from the cold block inside the sensor (2 plastic screws).
5. Disconnect the PMT from the HVPS.
6. Re-connect the 7 pin connector to the sensor end cap, and power-up the instrument.
7. Scroll the front panel display to the HVPS test parameter.
8. Divide the displayed HVPS voltage by 10 and test the pairs of connector points as shown in the figure below.
9. Check the overall voltage (should be equal to the HVPS value displayed on the front panel and the voltages between each pair of pins of the supply

EXAMPLE

If the HVPS signal is 700 V the pin-to-pin voltages should be 70 V.

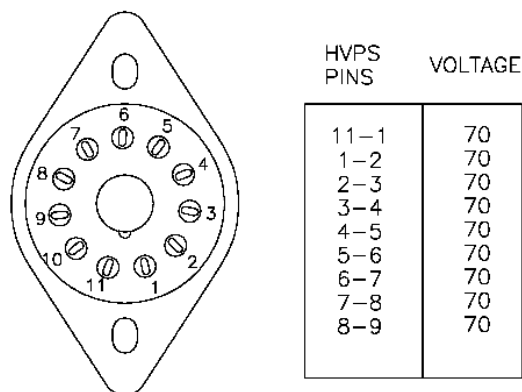

- Turn off the instrument power, and reconnect the PMT, and then reassemble the sensor.
 - If any faults are found in the test, you must obtain a new HVPS as there are no user serviceable parts inside the supply.

12.7.14. PMT TEMPERATURE CONTROL PCA

The TEC control PCA is located on the sensor housing assembly, under the slanted shroud, next to the cooling fins and directly above the cooling fan.

If the red LED located on the top edge of this assembly is not glowing the control circuit is not receiving power. Check the analyzers power supply, the relay board's power distribution circuitry and the wiring connecting them to the PMT temperature control PCA.

TEC Control Test Points

Four test points are also located at the top of this assembly they are numbered left to right start with the T1 point immediately to the right of the power status LED. These test points provide information regarding the functioning of the control circuit.

- To determine the current running through the control circuit, measure the voltage between T1 and T2. Multiply that voltage by 10.
- To determine the drive voltage being supplied by the control circuit to the TEC, measure the voltage between T2 and T3.
 - If this voltage is zero, the TEC circuitry is most likely open.

Or,

- If the voltage between T2 and T3 = 0 VDC and the voltage measured between T1 and T2 = 0 VDC there is most likely an open circuit or failed op amp on control PCA itself.
- If the voltage between T2 and T3 = 0 VDC and the voltage measured between T1 to T2 is some voltage other than 0 VDC, the TEC is most likely shorted.
- T4 is tied directly to ground. To determine the absolute voltage on any one of the other test points make a measurement between that test point and T4.

12.7.15. O₃ GENERATOR

The ozone generator can fail in two ways, electronically (printed circuit board) and functionally (internal generator components). Assuming that air is supplied properly to the generator, the generator should automatically turn on 30 minutes after the instrument is powered up or if the instrument is still warm. See Section 13.2.3 for ozone generator functionality. Accurate performance of the generator can only be determined with an ozone analyzer connected to the outlet of the generator. However, if the generator appears to be working properly but the sensitivity or calibration of the instrument is reduced, suspect a leak in the ozone generator supply air.

A leak in the dryer or between the dryer and the generator can cause moist, ambient air to leak into the air stream, which significantly reduces the ozone output. The generator will produce only about half of the nominal O₃ concentration when run with moist, ambient air instead of dried air. In addition, moist supply air will produce large amounts of nitric acid in the generator, which can cause analyzer components downstream of the generator to deteriorate and/or causes significant deposit of nitrate deposits on the reaction cell window, reducing sensitivity and causing performance drift. Carry out a leak check as described earlier in this Section.

12.7.15.1. O₃ Generator Override

This feature allows the user to manually turn the ozone generator off and on. This should be done before disconnecting the generator, to prevent ozone from leaking out, or after a system restart if the user does not want to wait for 30 minutes during warm-up time. To access this feature press the following buttons: (Also note that the ozone generator does not turn on if the ozone flow conditions are out of specification (e.g., if there is no flow through the system or the pump is broken).

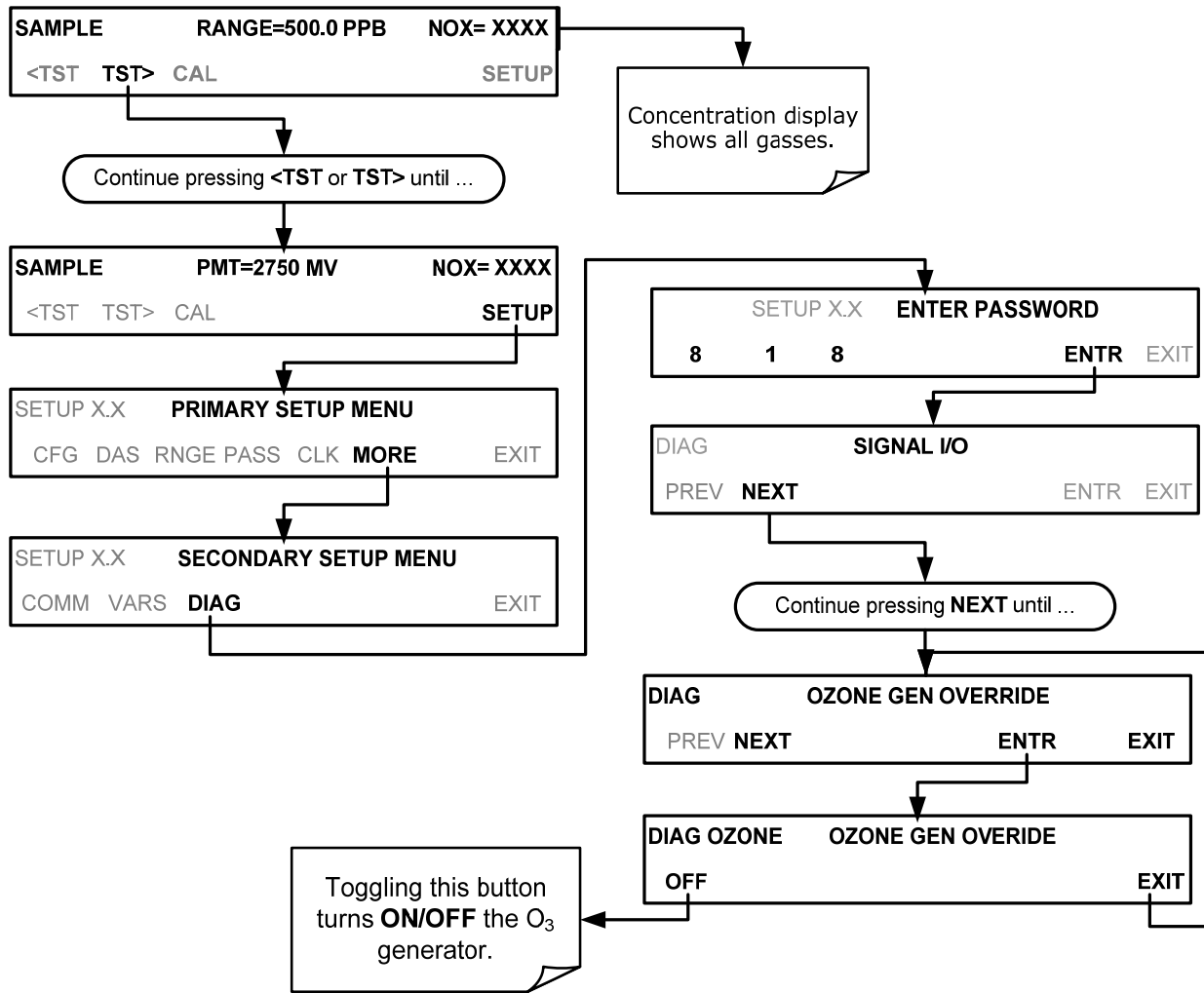

Note

This is one of the two settings in the DIAG menu that is retained after you exit the menu.

12.7.16. INTERNAL SPAN GAS GENERATOR AND VALVE OPTIONS

The zero/span valves and Internal span gas generator options need to be enabled in the software (contact the factory on how to do this).

- Check for the physical presence of the valves or the IZS option.
- Check front panel for correct software configuration. When the instrument is in SAMPLE mode, the front panel display should show CALS and CALZ buttons in the second line of the display. The presence of the buttons indicates that the option has been enabled in software. In addition, the IZS option is enabled if the TEST functions show a parameter named IZS TEMP.

The semi-permeable PTFE membrane of the permeation tube is severely affected by humidity. Variations in humidity between day and night are usually enough to yield very variable output results. If the instrument is installed in an air-conditioned shelter, the air is usually dry enough to produce good results. If the instrument is installed in an environment with variable or high humidity, variations in the

permeation tube output will be significant. In this case, a dryer for the supply air is recommended (dew point should be -20°C or less).

The permeation tube of the internal span gas generator option is heated with a proportional heater circuit and the temperature is maintained at $50^{\circ}\text{C} \pm 1^{\circ}\text{C}$. Check the front panel display or the **IZS_TEMP** signal voltage using the **SIGNAL I/O** function under the **DIAG** Menu (Section 5.9.1). At 50°C , the temperature signal from the IZS thermistor should be around 2500 mV.

12.7.17. TEMPERATURE SENSOR

12.7.17.1. Box Temperature Sensor

The box temperature sensor (thermistor) is mounted on the motherboard below the bottom edge of the CPU board when looking at it from the front. It cannot be disconnected to check its resistance.

- Box temperature will vary with, but will usually read about 5°C higher than, ambient (room) temperature because of the internal heating zones from the NO_2 converter, reaction cell and other devices.
- To check the box temperature functionality, we recommend checking the **BOX_TEMP** signal voltage using the **SIGNAL I/O** function under the **DIAG** Menu (Section 12.1.3).
- At about 30°C , the signal should be around 1500 mV.
- To check the accuracy of the sensor, use a calibrated external thermometer / temperature sensor to verify the accuracy of the box temperature by:
 - Placing it inside the chassis, next to the thermistor labeled **XT1** (above connector J108) on the motherboard.
 - Compare its reading to the value of the test function **PMT TEMP**.

12.7.17.2. PMT Temperature Sensor Control

The temperature of the PMT should be low and constant. It is more important that this temperature is maintained at a constant level than it is to be a specific temperature.

The PMT cooler uses a Peltier, thermo-electric cooler element supplied with 12 V DC power from the switching power supply PS2. The temperature is controlled by a proportional temperature controller located on the preamplifier board.

- Voltages applied to the cooler element vary from 0.1 to 12 VDC.
- The temperature set point (hard-wired into the preamplifier board) will vary by ± 2
- The actual temperature will be maintained to within 0.1°C around that set point.

To check the operation of the PMT temperature control system:

1. Turn off the analyzer and let its internal components cool / heat to ambient temperature.
2. Turn on the analyzer.
3. Set the front panel to show the **PMT TEMP** test function (see Section 4.1.1).
 - The temperature should fall steadily to $6\text{-}10^{\circ}\text{C}$.

- If the temperature fails to reach this point after 60 minutes, there is a problem in the cooler circuit.
- If the control circuit on the preamplifier board is faulty, a temperature of -1°C will be reported.

12.8. SERVICE PROCEDURES

This section contains some procedures that may need to be performed when a major component of the analyzer requires repair or replacement.

Note

Maintenance procedures (e.g., replacement of regularly changed expendables) are discussed in Section 11 (Instrument Maintenance) and are not listed here).

Also, there may be more detailed service notes for some of the below procedures. Contact Teledyne Customer Service Department.

**WARNING – ELECTRICAL SHOCK HAZARD**

Unless the procedure being performed requires the instrument be operating, turn it off and disconnect power before opening the analyzer and removing, adjusting or repairing any of its components or subsystems.

**CAUTION – QUALIFIED TECHNICIAN**

The operations outlined in this chapter are to be performed by qualified maintenance personnel only.

12.8.1. DISK-ON-MODULE REPLACEMENT PROCEDURE

Note

Servicing of circuit components requires electrostatic discharge protection, i.e. ESD grounding straps, mats and containers. Failure to use ESD protection when working with electronic assemblies will void the instrument warranty. Refer to Section 14 for more information on preventing ESD damage.

Replacing the Disk-on-Module (DOM) will cause loss of all DAS data; it may also cause loss of some instrument configuration parameters unless the replacement DOM carries the exact same firmware version. Whenever changing the version of installed software, the memory must be reset. Failure to ensure that memory is reset can cause the analyzer to malfunction, and invalidate measurements. After the memory is reset, the A/D converter must be re-calibrated, and all information collected in Step 1 below must be re-entered before the instrument will function correctly. Also, zero and span calibration should be performed.

1. Document all analyzer parameters that may have been changed, such as range, auto-cal, analog output, serial port and other settings before replacing the DOM.
2. Turn off power to the instrument, fold down the rear panel by loosening the mounting screws.
3. While looking at the electronic circuits from the back of the analyzer, locate the Disk-on-Module in the right-most socket of the CPU board.
4. The DOM should carry a label with firmware revision, date and initials of the programmer.

5. Remove the nylon standoff clip that mounts the DOM over the CPU board, and lift the DOM off the CPU. Do not bend the connector pins.
6. Install the new Disk-on-Module, making sure the notch at the end of the chip matches the notch in the socket.
7. It may be necessary to straighten the pins somewhat to fit them into the socket. Press the chip all the way in.
8. Close the rear panel and turn on power to the machine.
9. If the replacement DOM carries a firmware revision, re-enter all of the setup information.

12.8.2. O₃ GENERATOR REPLACEMENT

The ozone generator is a black, brick-shaped device with printed circuit board attached to its rear and two tubes extending out the right side in the front of the analyzer (see Figure 3-5). The board has a red LED that, when lit, indicates ozone is being generated. To replace the ozone generator:

1. Turn off the analyzer power, remove the power cord and the analyzer cover.
2. Disconnect the 1/8" black tube from the ozone cleanser and the 1/4" clear tube from the plastic extension tube at the brass fitting nearest to the ozone generator.
3. Unplug the electrical connection on the rear side of the brick.
4. Unscrew the two mounting screws that attach the ozone generator to the chassis and take out the entire assembly.
5. If you received a complete replacement generator with circuit board and mounting bracket attached, simply reverse the above steps to replace the current generator.

Note

Ensure to carry out a leak check (11.3.12) and a recalibration after the analyzer has warmed up for about 60 minutes.

12.8.3. SAMPLE AND OZONE (PERMA PURE[®]) DRYER REPLACEMENT

The 9110T standard configuration is equipped with a dryer for the ozone supply air. An optional dryer is available for the sample stream and a combined dryer for both gas streams can also be purchased. To change one or both of these dryers:

1. Turn off power to the analyzer and pump, remove the power cord and the analyzer cover.
2. Locate the dryers in the center of the instrument, between sensor and NO₂ converter (see Figure 3-5).
 - They are mounted to a bracket, which can be taken out when unscrewing the two mounting screws (if necessary).
3. Disconnect all tubing that extends out of the dryer assembly.
 - Take extra care not to twist any of the white plastic fittings on the dryer.

- These connect the inner drying tube to the outer purge tube and are delicate. See Sections 13.3.1 and 11.3.2.
4. Note the orientation of the dryer on the bracket.
 5. Cut the tie wraps that hold the dryer to the mounting bracket and take out the old dryer.
 - If necessary, unscrew the two mounting screws on the bracket and take out the entire assembly.
 6. Attach the replacement dryer to the mounting bracket in the same orientation as the old dryer.
 7. Fix the dryer to the bracket using new tie wraps.
 8. Cut off excess length of the wraps.
 9. Put the assembly back into the chassis and tighten the mounting screws.
 10. Re-attach the tubes to vacuum manifold, flow meter and/or NO/NOx valve using at least two wrenches.
 - Take extra care not to twist the dryer's white plastic fittings, as this will result in large leaks that are difficult to trouble-shoot and fix.
 11. Carry out a detailed leak check (see Section 11.3.12.2),
 12. Close the analyzer.
 13. Power up pump and analyzer and re-calibrate the instrument after it stabilizes.

12.8.4. PMT SENSOR HARDWARE CALIBRATION

The sensor module hardware calibration is used in the factory to adjust the slope and offset of the PMT output and to optimize the signal output and HVPS.

- If the instrument's slope and offset values are outside of the acceptable range and all other more obvious causes for this problem have been eliminated, the hardware calibration can be used to adjust the sensor as has been done in the factory.
- This procedure is also recommended after replacing the PMT or the preamplifier board.

To calibrate the PMT preamplifier PCA:

1. Perform a full zero point calibration using zero air (see Section 9).
2. Display the NOX STB test function on the front panel (Section 4.1.1).
3. Locate the preamplifier board (see Figure 3-5).
4. Locate the following components on the preamplifier board (Figure 12-8):
 - HVPS coarse adjustment switch (Range 0-9, then A-F).
 - HVPS fine adjustment switch (Range 0-9, then A-F).

- Gain adjustment potentiometer (Full scale is 10 turns).
5. Turn the gain adjustment potentiometer 12 turns clockwise or to its maximum setting.
 6. Feed NO gas into the analyzer.
 - This should be 90% of the upper limit setting for the 9110T's reporting range:

EXAMPLE: if the reporting range is set at 500 ppb, use 450 ppb NO.

7. Wait until the **STB** value is below 0.5 ppb

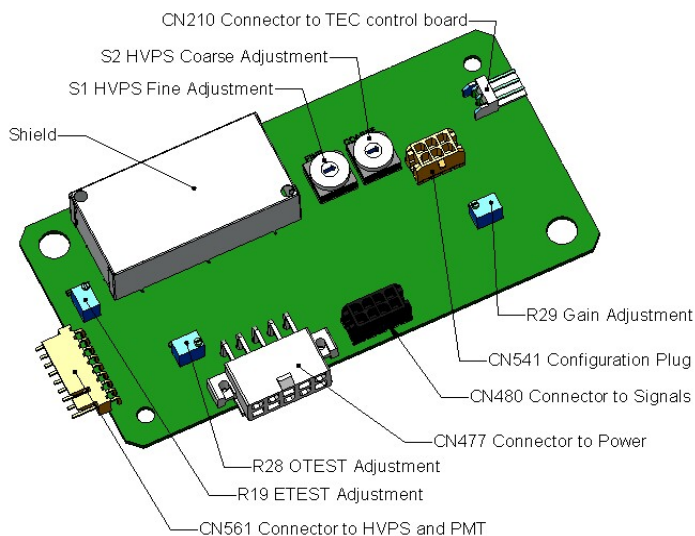

Figure 12-8: Pre-Amplifier Board Layout

8. Scroll to the NORM PMT test function on the analyzer's front panel.
9. With the NO gas concentrations mentioned in Step 5 above, the norm pmt value should be 900 mV.
10. Set the HVPS coarse adjustment to its minimum setting (0).
11. Set the HVPS fine adjustment switch to its maximum setting (F).
 - Set the HVPS coarse adjustment switch to the lowest setting that will give you just above the target value for NORM PMT signal.
12. Adjust the HVPS fine adjustment such that the **NORM PMT** value is close to the target value.
 - It may be necessary to go back and forth between coarse and fine adjustments if the proper value is at the threshold of the min/max coarse setting.

ATTENTION

COULD DAMAGE INSTRUMENT AND VOID WARRANTY
 Do not overload the PMT by accidentally setting both adjustment switches to their maximum setting. Start at the lowest setting and increment

slowly. Wait 10 seconds between adjustments.

Note

During these adjustments, the NORM PMT value will fluctuate as the analyzer continues to switch between NO and NOx streams as well as between measure and Auto Zero modes.

13. Perform a span point calibration (see Section 9) to normalize the sensor response to its new PMT sensitivity.
14. Review the slope and offset values:
 - The slope values should be 1.000 ± 0.300 .
 - The offset values should be approximately 0.0 (-20 to +150 mV is allowed).

12.8.5. REPLACING THE PMT, HVPS OR TEC

The photo multiplier tube (PMT) should last for the lifetime of the analyzer, however, the high voltage power supply (HVPS) or the thermo-electric cooler (TEC) components may fail. Replacing any of these components requires opening the sensor module. This is a delicate assembly and it is recommend that you ensure the PMT, HVPS or TEC modules are, indeed, faulty before unnecessarily opening of the module.



**CAUTION
QUALIFIED PERSONNEL**

While the PMT or HVPS can be removed through the front panel without unmounting the entire sensor module, we recommend turning off the instrument, opening its top cover and removing the entire assembly so that further repairs can be carried out at an anti-ESD workstation.

Follow the guidelines defined in Section 14 for preventing electrostatic damage to electronic components.

1. Turn OFF the analyzer and disconnect the power cord.
2. Remove the cover.
3. Disconnect all pneumatic and electrical connections from the sensor assembly.
4. Remove the sensor assembly.
5. If the TEC is to be replaced, remove the reaction cell assembly at this point by unscrewing two holding screws.
 - This is necessary only if the repair being performed involves removing the PMT cold block.

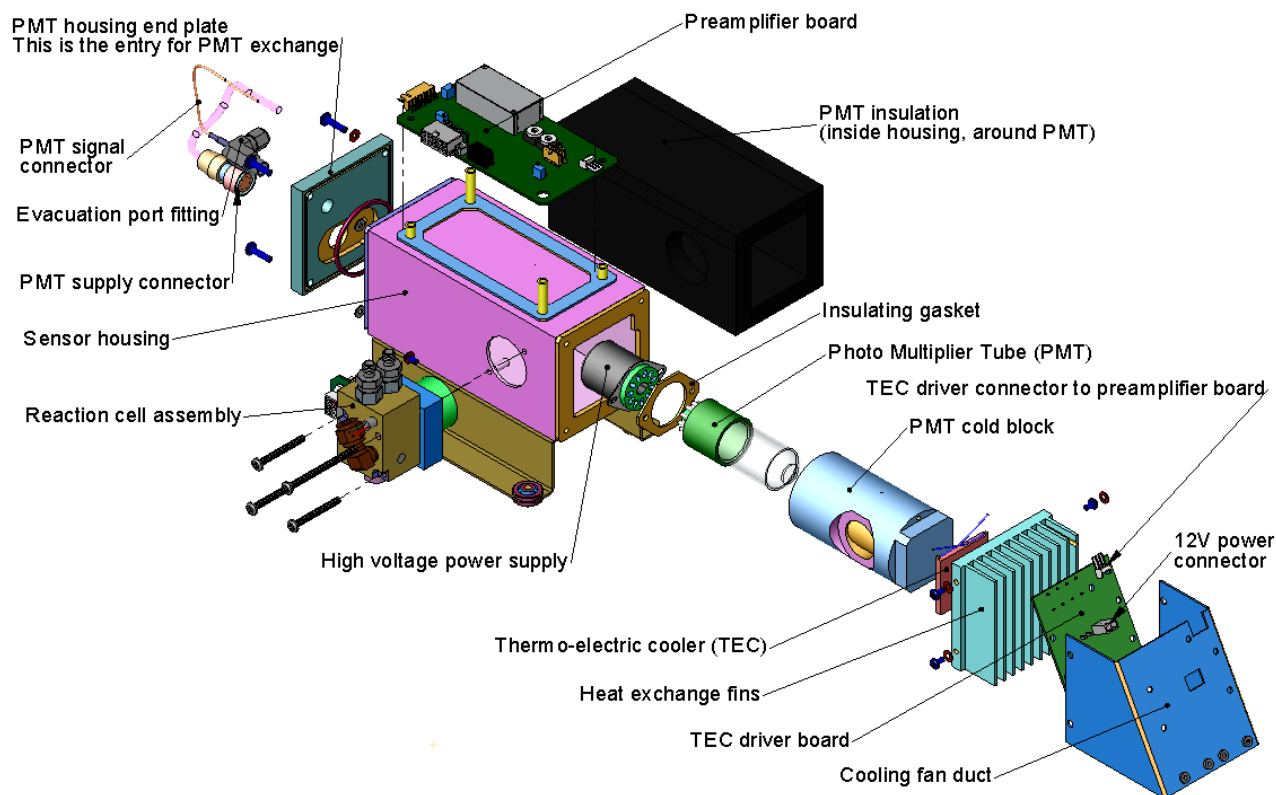

Figure 12-9: 9110T Sensor Assembly

6. Remove the two connectors on the PMT housing end plate facing towards the front panel.
7. Remove the end plate itself (4 screws with plastic washers).

Note

If the black PMT housing end plate for the Sensor Assembly is removed, ensure to replace the 5 desiccant bags inside the housing.

8. Remove the dryer packages inside the PMT housing.
9. Unscrew the PMT assembly, which is held to the cold block by two plastic screws.
10. Discard the plastic screws and replace with new screws at the end of this procedure (the threads get stripped easily and it is recommended to use new screws).
11. Along with the plate, slide out the OPTIC TEST LED and the thermistor that measures the PMT temperature.
 - Thermistor will be coated with a white, thermal conducting paste.
 - Do not contaminate the inside of the housing with this grease, as it may contaminate the PMT glass tube on re-assembly.
12. Carefully take out the assembly consisting of the HVPS, the gasket and the PMT.

13. Change the PMT or the HVPS or both, clean the PMT glass tube with a clean, anti-static wipe and do not touch it after cleaning.
14. If the cold block or TEC is to be changed:
 - Disconnect the TEC driver board from the preamplifier board, remove the cooler fan duct (4 screws on its side) including the driver board.
 - Disconnect the driver board from the TEC and set the sub-assembly aside.
15. Remove the end plate with the cooling fins (4 screws) and slide out the PMT cold block assembly, which contains the TEC.
16. Unscrew the TEC from the cooling fins and the cold block and replace it with a new unit.
17. Reassemble this TEC subassembly in reverse order.
 - Ensure to use thermal grease between TEC and cooling fins as well as between TEC and cold block and that the side opening in the cold block will face the reaction cell when assembled.
 - Evenly tighten the long mounting screws for good thermal conductivity.



CAUTION
QUALIFIED PERSONNEL

The thermo-electric cooler needs to be mounted flat to the heat sink. If there is any significant gap, the TEC might burn out. Ensure to apply heat sink paste before mounting it and tighten the screws evenly and cross-wise.

18. Reinsert the TEC subassembly in reverse order.
 - Ensure that the O-ring is placed properly and the assembly is tightened evenly.
19. Insert the LED and thermistor into the cold block, insert new drying packages and carefully replace the end plate by making sure that the O-ring is properly in place.
 - Improperly placed O-rings will cause leaks, which – in turn – cause moisture to condense on the inside of the cooler and likely cause a short in the HVPS.
20. Reinsert the PMT/HVPS subassembly in reverse order.
 - Don't forget the gasket between HVPS and PMT.
 - Use new plastic screws to mount the PMT assembly on the PMT cold block.
21. Install new silica gel packets (desiccant bags).
22. Reconnect the cables and the reaction cell (evenly tighten these screws).
23. Replace the sensor assembly into the chassis and fasten with four screws and washers.
24. Reconnect all electrical and pneumatic connections.

25. Leak check the system (see Section 13.3.12).
26. Turn ON the analyzer.
27. Verify the basic operation of the analyzer using the ETEST(12.7.12.2) and OTEST features (12.7.12.1) or zero and span gases, then carry out a hardware calibration of the analyzer followed by a zero/span point calibration (See Section 9.4.3.2).

12.8.6. REMOVING / REPLACING THE RELAY PCA FROM THE INSTRUMENT

This is the most commonly used version of the Relay PCA. It includes a bank of solid state AC relays. This version is installed in analyzers where components such as AC powered heaters must be turned ON & OFF.

A retainer plate is installed over the relay to keep them securely seated in their sockets.

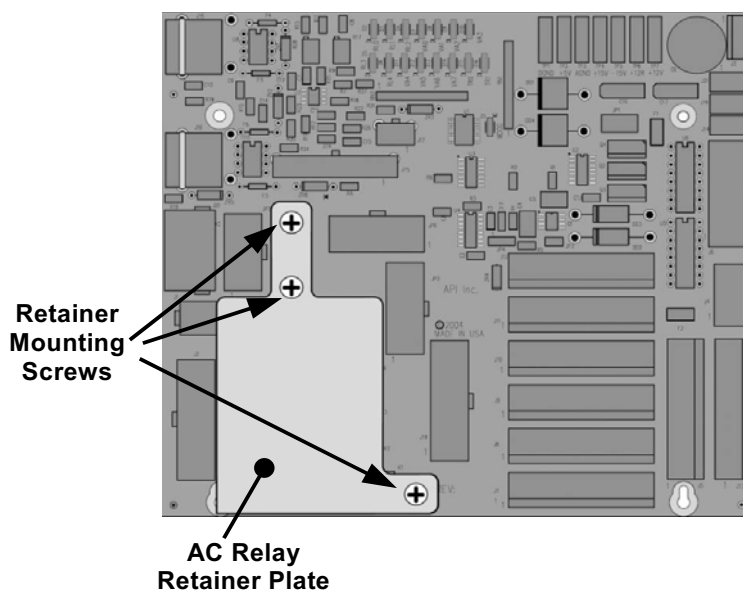

Figure 12-10: Relay PCA with AC Relay Retainer In Place

The Relay retainer plate installed on the relay PCA covers the lower right mounting screw of the relay PCA. Therefore, when removing the relay PCA, the retainer plate must be removed first.

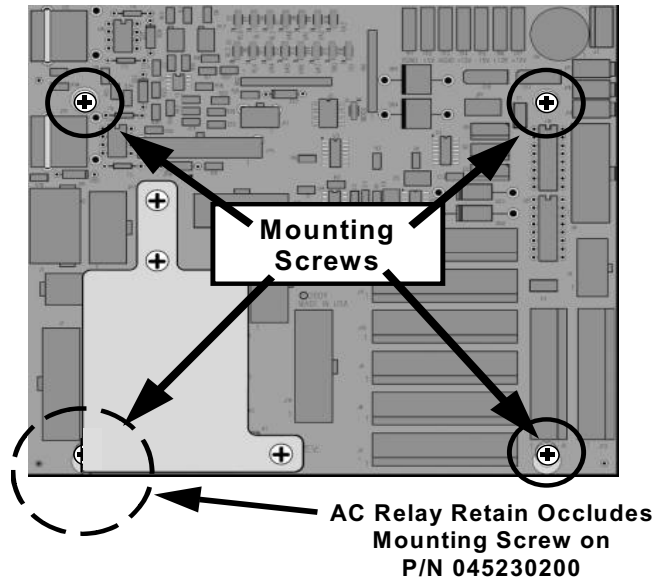

Figure 12-11: Relay PCA Mounting Screw Locations

12.9. FREQUENTLY ASKED QUESTIONS

The following list was compiled from the TAI's Customer Service Department's 10 most commonly asked questions relating to the 9110T NOx Analyzer.

QUESTION	ANSWER
Why does the ENTR button sometimes disappear on the front panel display?	Sometimes the ENTR button will disappear if you select a setting that is invalid or out of the allowable range for that parameter, such as trying to set the 24-hour clock to 25:00:00 or a range to less than 1 or more than 20000 ppb. Once you adjust the setting to an allowable value, the ENTR button will re-appear.
Why is the ZERO or SPAN button not displayed during calibration?	The 9110T disables certain these buttons expected span or zero value entered by the users is too different from the gas concentration actually measured value at the time. This is to prevent the accidental recalibration of the analyzer to an out-of-range response curve. EXAMPLE: The span set point is 400 ppb but gas concentration being measured is only 50 ppb.
How do I enter or change the value of my Span Gas?	Press the CONC button found under the CAL or CALS buttons of the main SAMPLE display menus to enter the expected NO _x span concentration. See Section 9.2.3.1 or for more information.
Can I automate the calibration of my analyzer?	Any analyzer with zero/span valve or IZS option can be automatically calibrated using the instrument's AutoCal feature.

QUESTION	ANSWER
Can I use the IZS option to calibrate the analyzer?	<p>Yes. However, the accuracy of the IZS option's permeation tube is only $\pm 5\%$. Whereas this may be acceptable for basic calibration checks, the IZS option is not permitted as a calibration source in applications following US EPA protocols.</p> <p>To achieve highest accuracy, it is recommended to use cylinders of calibrated span gases in combination with a zero air source.</p>
How do I measure the sample flow?	<p>Sample flow is measured by attaching a calibrated flow meter to the sample inlet port when the instrument is operating. The sample flow should be $500 \text{ cm}^3/\text{min} \pm 10\%$.</p> <p>Section 13.3.12.3 includes detailed instructions on performing a check of the sample gas flow.</p>
Can I use the DAS system in place of a strip chart recorder or data logger?	<p>Yes. Section 7 describes the setup and operation of the DAS system in detail.</p>
How often do I need to change the particulate filter?	<p>Once per week or as needed. Section 11 contains a maintenance schedule listing the most important, regular maintenance tasks. Highly polluted sample air may require more frequent changes.</p>
How long does the sample pump last?	<p>The sample pump should last one to two years and the pump head should be replaced when necessary. Use the RCEL pressure indicator on the front panel to see if the pump needs replacement.</p> <p>If this value goes above 10 in-Hg-A, on average, the pump head needs to be rebuilt.</p>
Why does my RS-232 serial connection not work?	<p>There are several possible reasons:</p> <ul style="list-style-type: none"> • The wrong cable: please use the provided or a generic "straight-through" cable (do not use a "null-modem" type cable) and ensure the pin assignments are correct (Sections 3.3.1.8 and 6.3). • The DCE/DTE switch on the back of the analyzer is not set properly; ensure that both green and red lights are on (Section 6.1). • The baud rate of the analyzer's COMM port does not match that of the serial port of your computer/data logger (Section 6.2.2).
How do I make the instrument's display and my data logger agree?	<p>This most commonly occurs when an independent metering device is used besides the data logger/recorder to determine gas concentration levels while calibrating the analyzer. These disagreements result from the analyzer, the metering device and the data logger having slightly different ground levels.</p> <p>Use the data logger itself as the metering device during calibration procedures.</p>

QUESTION	ANSWER
Do the critical flow orifices of my analyzer require regular replacement?	No. The o-rings and the sintered filter associated with them require replacement once a year, but the critical flow orifices do not. See Section 11 for instructions.
How do I set up and use the Contact Closures (Control Inputs) on the Rear Panel of the analyzer?	See Section 3.3.1.6.

12.10. TECHNICAL ASSISTANCE

If this manual and its troubleshooting & service section do not solve your problems, technical assistance may be obtained from Teledyne's Customer Service Department at:

TELEDYNE ELECTRONIC TECHNOLOGIES
Analytical Instruments

16830 Chestnut Street
City of Industry, CA 91748

Telephone: (626) 934-1500
Fax: (626) 961-2538

Web: www.teledyne-ai.com
or your local representative.

Before you contact Teledyne Customer Service, fill out the problem report form in Appendix C, which is also available online for electronic submission at <http://www.teledyne-api.com/manuals/>.

13. PRINCIPLES OF OPERATION

The 9110T Nitrogen Oxides Analyzer is a microprocessor controlled instrument that determines the concentration of nitric oxide (NO), total nitrogen oxides (NO_x, the sum of NO and NO₂) and nitrogen dioxide (NO₂) in a sample gas drawn through the instrument.

- It requires that sample and calibration gases be supplied at ambient atmospheric pressure in order to establish a constant gas flow through the reaction cell where the sample gas is exposed to ozone (O₃), initiating a chemical reaction that gives off light (hν).
- The instrument measures the amount of chemiluminescence to determine the amount of NO in the sample gas.
- A catalytic-reactive converter converts NO₂ in the sample gas to NO which, along with the NO present in the sample is reported as NO_x. NO₂ is calculated as the difference between NO_x and NO.

Calibration of the instrument is performed in software and usually does not require physical adjustments to the instrument. During calibration, the microprocessor measures the sensor output signal when gases with known amounts of NO or NO₂ are supplied and stores these results in memory. The microprocessor uses these calibration values along with the signal from the sample gas and data of the current temperature and pressure of the gas to calculate a final NO_x concentration.

The concentration values and the original information from which it was calculated are stored in the unit's internal data acquisition system (DAS Section 7) and are reported to the user through a vacuum fluorescence display or several output ports.

13.1. MEASUREMENT PRINCIPLE

13.1.1. CHEMILUMINESCENCE CREATION IN THE 9110T REACTION CELL

The 9110T's measures the amount of NO present in a gas by detecting the chemiluminescence which occurs when nitrogen oxide (NO) is exposed to ozone (O₃). This reaction is a two-step process:

- In the first step, one molecule of NO and one molecule of O₃ collide and chemically react to produce one molecule of oxygen (O₂) and one molecule of nitrogen dioxide (NO₂). Some of the NO₂ molecules created by this reaction retain excess energy from the collision and exist in an excited state, where one of the electrons of the NO₂ molecule resides in a higher energy state than normal (denoted by an asterisk in the following equation).

Equation 13-1

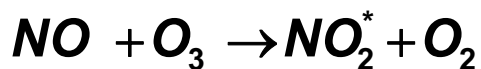

- The second step occurs because the laws of thermodynamics require that systems seek the lowest stable energy state available, therefore the excited NO₂ molecule quickly returns to its ground state, releasing the excess energy. This release takes the form of a quantum of light (hν). The distribution of wavelengths for these quanta range between 600 and 3000 nm, with a peak at about 1200 nm.

Equation 13-2

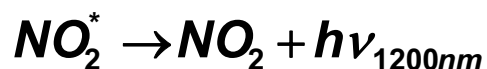

All things being constant (temperature, pressure, amount of ozone present, etc.), the relationship between the amount of NO present in the reaction cell and the amount of light emitted from the reaction is very linear. If more NO is present, more IR light is produced. By measuring the amount of IR light produced with a sensor sensitive in the near-infrared spectrum (see Figure 13-2) the amount of NO present can be determined.

In addition, sometimes the excited NO₂ collides with other gaseous molecules in the reaction cell chamber or even the molecules of the reaction cell walls and transfers its excess energy to this collision partner (represented by *M* in the equation 12-3 below) without emitting any light at all. In fact, by far the largest portion of the excited NO₂ returns to the ground state this way, leaving only a few percent yield of usable chemiluminescence.

Equation 13-3

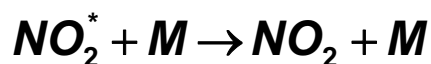

The probability of a collision between the NO₂* molecule and a collision partner *M* increases proportionally with the reaction cell pressure. This non-radiating collision with the NO₂* molecules is usually referred to as *third body quenching*, an unwanted process further described in Section 13.1.5.2.

Even under the best conditions only about 20% of the NO₂ that is formed by the reaction described in equation 12-1 is in the excited state. In order to maximize chemiluminescence, the reaction cell is maintained at reduced pressure (thereby reducing the amount of available collision partners) and is supplied with a large, constant excess of ozone (about 3000-5000 ppm) from the internal ozone generator.

13.1.2. CHEMILUMINESCENCE DETECTION IN THE 9110T REACTION CELL

13.1.2.1. The Photo Multiplier Tube (PMT)

The 9110T uses a special kind of vacuum tube, called a photo-multiplier tube (PMT), to detect the amount of light created by the NO and O₃ reaction in the reaction cell.

Photons enter the PMT and strike a negatively charged photo cathode causing it to emit electrons. These electrons are accelerated by an applied high voltage and multiplied through a sequence of similar acceleration steps (dynodes) until a useable current signal is generated (see Section 13.5 for a more detailed description). The more light present (in this case photons given off by the chemiluminescent reaction described above), the more current is produced. Therefore the more NO present in the reaction cell the more current is produced by the PMT.

The current produced by the PMT is converted to a voltage and amplified by the preamplifier board and then communicated to the 9110T's CPU via the A → D converter circuitry on the analyzer.

13.1.2.2. Optical Filter

A high pass optical filter, only transparent to wavelengths of light above 645nm, placed between the reaction cell and the PMT (see Figure 13-1) in conjunction with the response characteristics of the PMT creates a very narrow window of wavelengths of light to which the 9110T will respond.

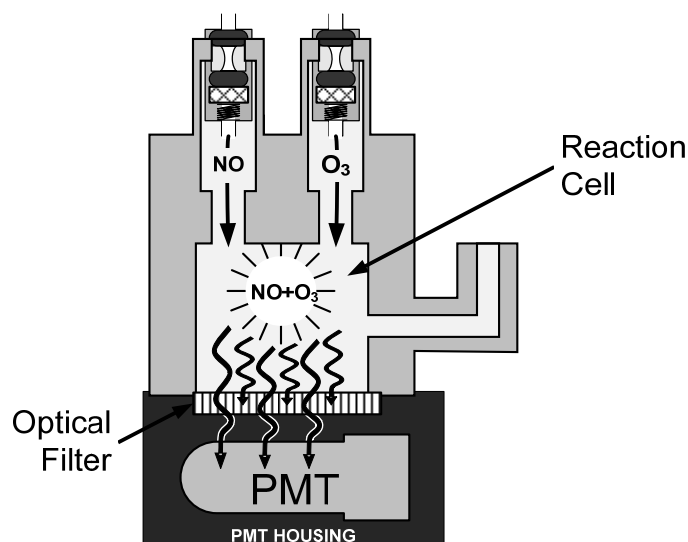

Figure 13-1: Reaction Cell with PMT Tube and Optical Filter

The narrowness of this band of sensitivity allows the 9110T to ignore extraneous light and radiation that might interfere with the 9110T’s measurement. For instance, some oxides of sulfur can also be chemiluminescent emitters when in contact with O₃ but give off light at much shorter wavelengths (usually around 260nm to 480nm).

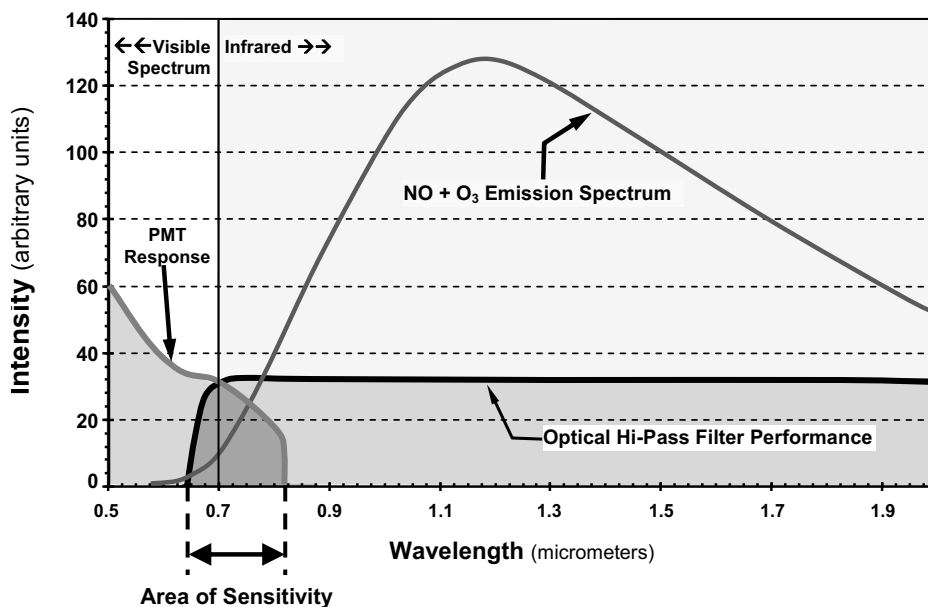

Figure 13-2: 9110T Sensitivity Spectrum

13.1.3. NO_x AND NO₂ DETERMINATION

The only gas that is actually measured by the 9110T is NO. NO₂, and therefore NO_x (which is defined here as the sum of NO and NO₂ in the sample gas), contained in the gas is not detected because NO₂ does not react with O₃ to create chemiluminescence.

In order to measure the concentration of NO₂, and therefore the concentration of NO_x, the 9110T periodically switches the sample gas stream so that the pump pulls it through a special converter cartridge filled with molybdenum (Mo, “moly”) chips that are heated to a temperature of 315°C.

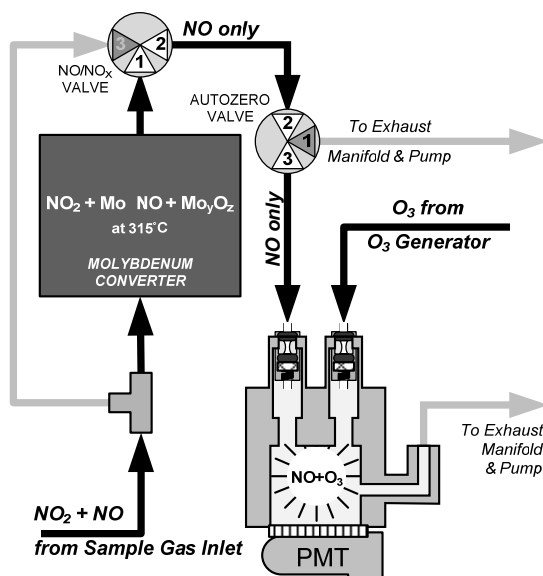

Figure 13-3: NO₂ → NO Conversion

The heated molybdenum reacts with NO₂ in the sample gas and produces a NO gas and a variety of molybdenum.

Equation 13-4



Once the NO₂ in the sample gas has been converted to NO, it is routed to the reaction cell where it undergoes the chemiluminescence reaction described in Equation 13-1 and Equation 13-2.

By converting the NO₂ in the sample gas into NO, the analyzer can measure the total NO_x content of the sample gas (i.e. the NO present + the converted NO₂ present). By switching the sample gas stream in and out of the “moly” converter every 6 - 10 seconds, the 9110T analyzer is able to quasi-continuously measure both the NO and the total NO_x content.

Finally, the NO₂ concentration is not directly measured but calculated by subtracting the known NO content of the sample gas from the known NO_x content.

13.1.4. AUTO ZERO

Inherent in the operation of any PMT is a certain amount of noise. This is due to a variety of factors such as black body infrared radiation given off by the metal components of the reaction cell, unit to unit variations in the PMT units and even the constant universal background radiation that surrounds us at all times. In order to reduce this amount of noise and offset, the PMT is kept at a constant 7° C (45° F) by a Thermo-Electric Cooler (TEC).

While this intrinsic noise and offset is significantly reduced by cooling the PMT, it is not eradicated. To determine how much noise remains, once every minute for about 8 seconds the 9110T diverts the sample gas flow directly to the vacuum manifold without passing the reaction cell.

During this time, only O₃ is present in the reaction cell, effectively turning off the chemiluminescence reaction. Once the chamber is completely dark, the 9110T records the output of the PMT and keeps a running average of these **AZERO** values. This average offset value is subtracted from the raw PMT readings while the instrument is measuring NO and NO_x to arrive at an Auto Zero corrected reading.

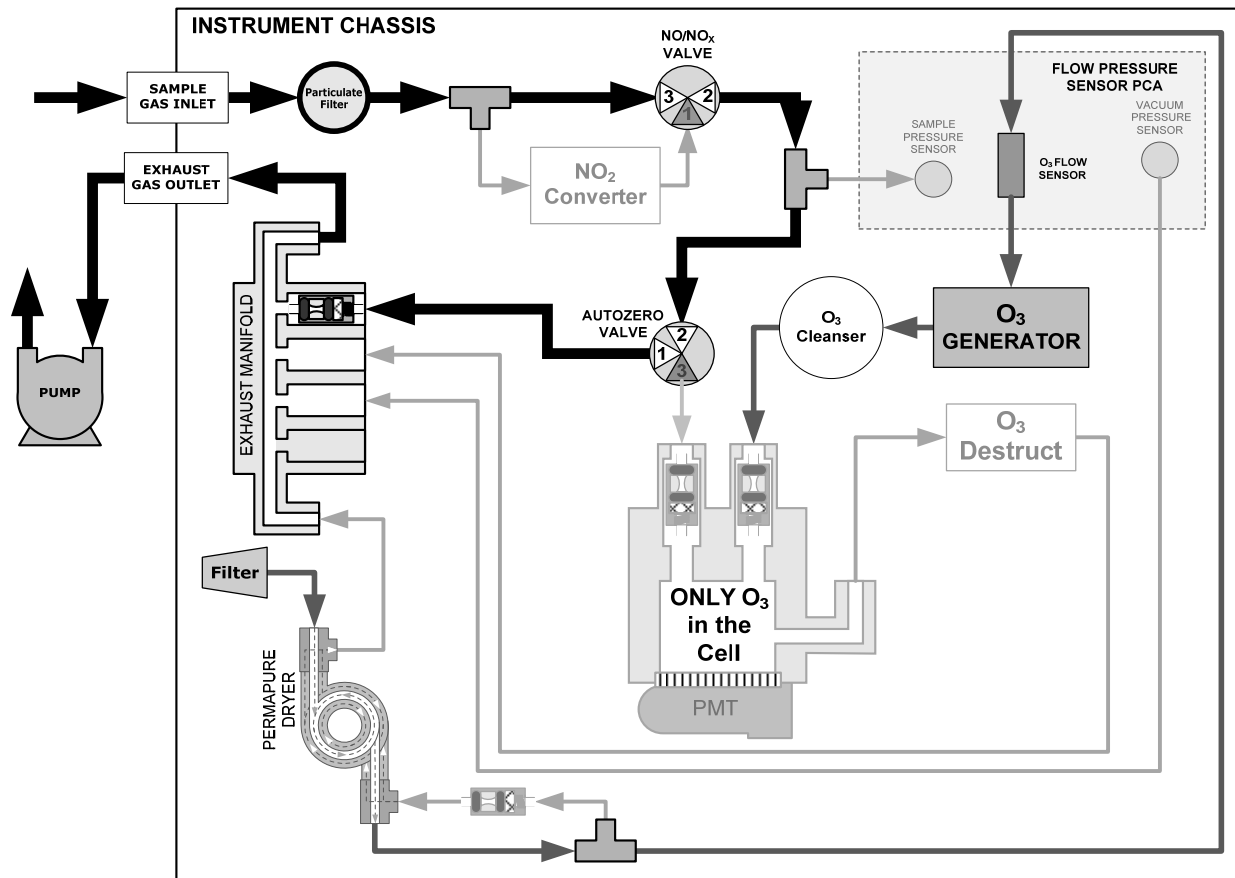

Figure 13-4: Pneumatic Flow During the Auto Zero Cycle

13.1.5. MEASUREMENT INTERFERENCES

It should be noted that the chemiluminescence method is subject to interferences from a number of sources. The 9110T has been successfully tested for its ability to reject interference from most of these sources. Table 13-1 list the most common types of interferences that could affect the performance of your 9110T.

13.1.5.1. Direct Interference

Some gases can directly alter the amount of light detected by the PMT due to chemiluminescence in the reaction cell. This can either be a gas that undergoes chemiluminescence by reacting with O₃ in the reaction cell or a gas that reacts with other compounds and produces excess NO upstream of the reaction cell.

13.1.5.2. Third Body Quenching

As described by Equation 13-3, other molecules in the reaction cell can collide with the excited NO_2^* , causing the excited NO_2^* to return to its ground state without releasing a photon of light. This is known as third party quenching.

Quenching is an unwanted phenomenon and the extent to which it occurs depends on the properties of the collision partner.

- Larger, more polarized molecules such as H_2O and CO_2 are the most significant quenching interferents of NO chemiluminescence.
 - The influence of water vapor on the 9110T measurement can be eliminated with an optional, internal sample gas dryer (see Section 3.3.2.6).
 - The interference of varying CO_2 amounts at low concentrations (less than 0.5%) is negligible.
 - In cases with excessively high CO_2 concentrations (larger than 0.5%), the effect can be calibrated out by using calibration gases with a CO_2 content equal to the measured air.
 - Only very high and highly variable CO_2 concentrations will then cause a measurable interference. For those applications, it is recommended to use other analyzer models. Please consult TAI Sales Department or our website (see Section 12.10).
- Smaller less polar and electronically “harder” molecules such as N_2 and O_2 can cause interference of this type as well, however, the concentrations of N_2 and O_2 are virtually constant in ambient air measurements, hence provide a constant amount of quenching that is accounted for in the calibration of the instrument .

13.1.5.3. Light Leaks

The 9110T sensitivity curve includes a small portion of the visible light spectrum (see Figure 13-2), therefore it is important to ensure that the reaction cell is completely sealed with respect to light. To ensure this:

- All pneumatic tubing leading into the reaction cell is opaque in order to prevent light from entering the cell.
- Light penetration is prevented by stainless steel filters and orifices.

Table 13-1: List of Interferents

Gas	Interference Type	Rejection Method
CO ₂	Dilution: Viscosity of CO ₂ molecules causes them to collect in aperture of Critical Flow Orifice altering flow rate of NO.	If high concentrations of CO ₂ are suspected, special calibration methods must be performed to account for the affects of the CO ₂ . Contact TAI's Customer Service Department (see Section 12.10) for details.
	3 rd Body Quenching: CO ₂ molecules collide with NO ₂ * molecules absorbing excess energy kinetically and preventing emission of photons.	
SO _x	Some SO _x variants can also initiate a chemiluminescence reaction upon exposure to O ₃ producing excess light.	Wavelengths of light produced by chemiluminescence of SO _x are screened out by the Optical Filter.
	Chemically reacts with NH ₃ , O ₂ and H ₂ O in O ₃ generator to create (NH ₃) ₂ SO ₄ (ammonium sulfate) and NH ₃ NO ₂ (ammonium nitrate) which form opaque white deposits on optical filter window. Also forms highly corrosive HNO ₃ (Nitric Acid)	Most of the ammonium sulfate and ammonium nitrate produced is removed from the sample gas by an air purifier located between the O ₃ Generator and the reaction cell.
	3 rd Body quenching: SO _x molecules collide with NO ₂ * molecules absorbing excess energy kinetically and preventing emission of photons.	If high concentrations of SO _x are suspected, special calibration methods must be performed to account for the affects of the SO ₂ . Contact Teledyne Customer Service Department (see Section 12.10) for details.
H ₂ O	3 rd Body quenching: H ₂ O molecules collide with NO ₂ * molecules absorbing excess energy kinetically and preventing emission of light.	Analyzer's operating in high humidity areas must have some drying applied to the sample gas (see Section 3.3.2.6 for more details).
	Water also reacts with NH ₃ and SO _x in the O ₃ generator to create (NH ₃) ₂ SO ₄ (ammonium sulfate) and NH ₃ NO ₂ (ammonium nitrate) which form opaque white deposits on the optical filter window. This also forms highly corrosive HNO ₃ (nitric acid)	Water is effectively removed from the O ₃ gas stream by the Perma Pure [®] Dryer (Section 13.2.3.2 for more details). We offer several Perma Pure [®] dryers for the sample stream (see Section 3.3.2.6 for more details).
NH ₃	Direct Interference: NH ₃ is converted to H ₂ O and NO by the NO ₂ converter. Excess NO reacts with O ₃ in the reaction cell creating a chemiluminescence artifact.	If a high concentration of NH ₃ is suspected, steps must be taken to remove the NH ₃ from the sample gas prior to its entry into the NO ₂ converter (see Section 3.3.2.6 for more details).
	NH ₃ also reacts with H ₂ O, O ₂ and SO _x in the O ₃ generator to create (NH ₃) ₂ SO ₄ (ammonium sulfate) and NH ₃ NO ₂ (ammonium nitrate) which form opaque white deposits on optical filter window. Also forms highly corrosive HNO ₃ (nitric acid).	The Perma Pure [®] dryer built into the 9110T is sufficient for removing typical ambient concentration levels of NH ₃ .

13.1.5.4. Reaction Cell Temperature Control

The stability of the chemiluminescence reaction between NO and O₃ can be affected by changes in the temperature and pressure of the O₃ and sample gases in the reaction cell. In order to reduce temperature effects, the reaction cell is maintained at a constant 50° C, just above the high end of the instrument's operation temperature range.

Two AC heaters, one embedded into the bottom of the reaction cell, the other embedded directly above the chamber's exhaust fitting, provide the heat source. These heaters operate off of the instrument's main AC power and are controlled by the CPU through a power relay on the relay board (see Section 13.3.4.4).

A thermistor, also embedded in the bottom of the reaction cell, reports the cell's temperature to the CPU through the thermistor interface circuitry of the motherboard (see Section 13.3.3.3).

13.2. PNEUMATIC OPERATION

IMPORTANT**IMPACT ON READINGS OR DATA**

Could either affect accuracy of instrument readings or cause loss of data.

Note

The sample gas is the most critical flow path in the analyzer. At any point before and in the reaction cell, the integrity of the sample gas cannot be compromised. Therefore, it is important that the sample airflow system is both leak tight and not pressurized over ambient pressure.

Regular leak checks should be performed on the analyzer as presented in the maintenance schedule, Table 13-1. Procedures for correctly performing leak checks can be found in Section 13.3.12.

13.2.1. SAMPLE GAS FLOW

Note

In this section of the manual vacuum readings are given in inches of mercury absolute (In-Hg-A). This pressure value is referenced against zero (a perfect vacuum).

The gas flow for the 9110T is created by a pump that is pneumatically downstream from the rest of the instrument's components. This is either:

- An external pump pneumatically connected to the analyzer's exhaust port located on the rear panel. This is the most common configuration for the 9110T (see Figure 13-5), or;
- An optional internal pump pneumatically connected between the vacuum manifold and the exhaust outlet. (see Figure 13-6).

In either case the pump creates a vacuum of approximately 5 in-Hg-A at one standard liter/minute, which is provided to various pneumatic components by a vacuum manifold located just in front of the rear panel (see Figure 3-5).

Gas flow is created by keeping the analyzer's sample gas inlet near ambient pressure, usually by means of a small vent installed in the sample line at the inlet, in effect pulling the gas through the instrument's pneumatic systems.

By placing the pump downstream from the analyzer's reaction cell, several problems are avoided.

- First, the pumping process heats and compresses the sample air complicating the measurement process.
- Additionally, certain physical parts of the pump itself are made of materials that might chemically react with the sample gas.
- Finally, in certain applications where the concentration of the target gas might be high enough to be hazardous, maintaining a negative gas pressure relative to ambient means that should a minor leak occur, no sample gas would be pumped into the atmosphere surrounding the analyzer.

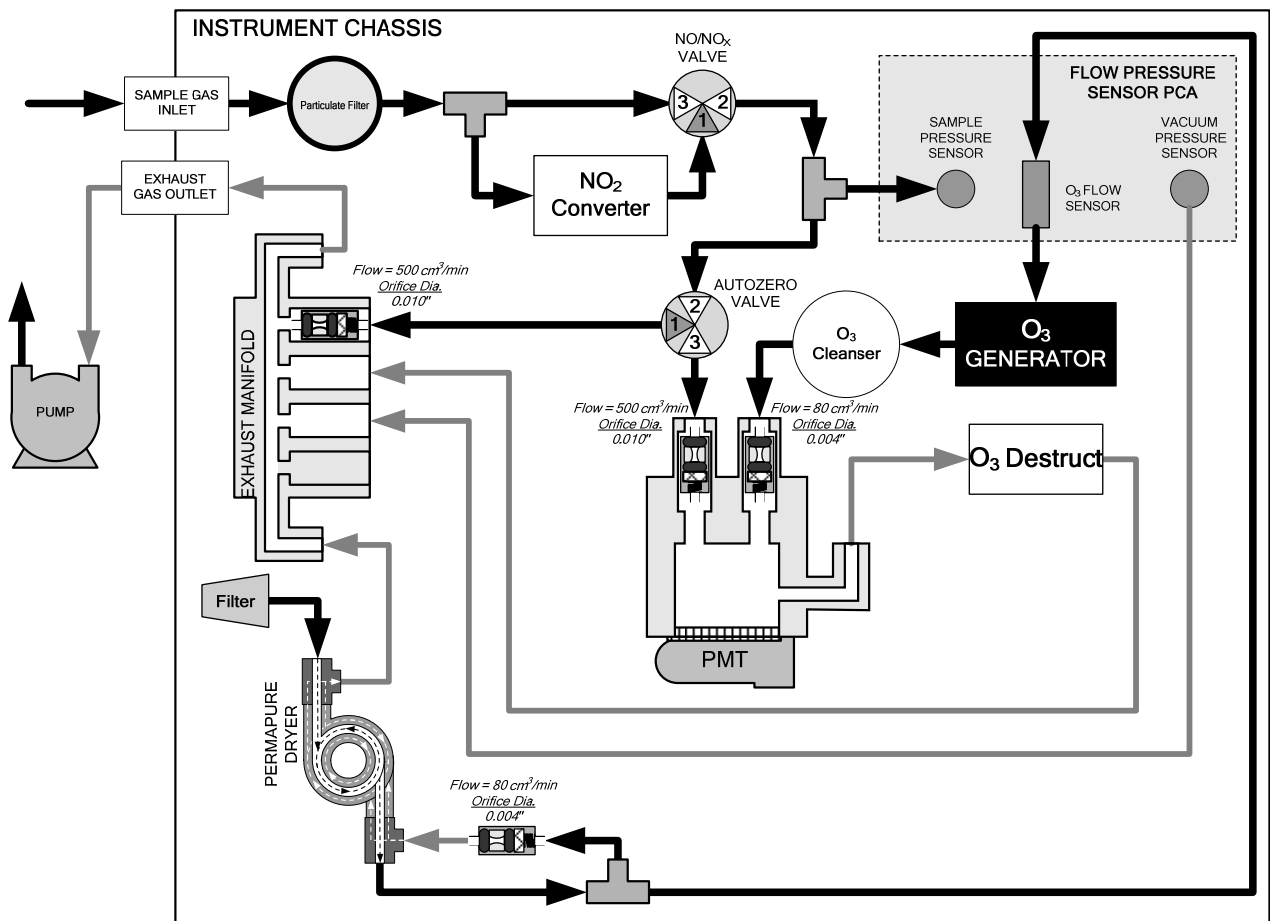

Figure 13-5: Internal Gas Flow for Basic 9110T with External Pump

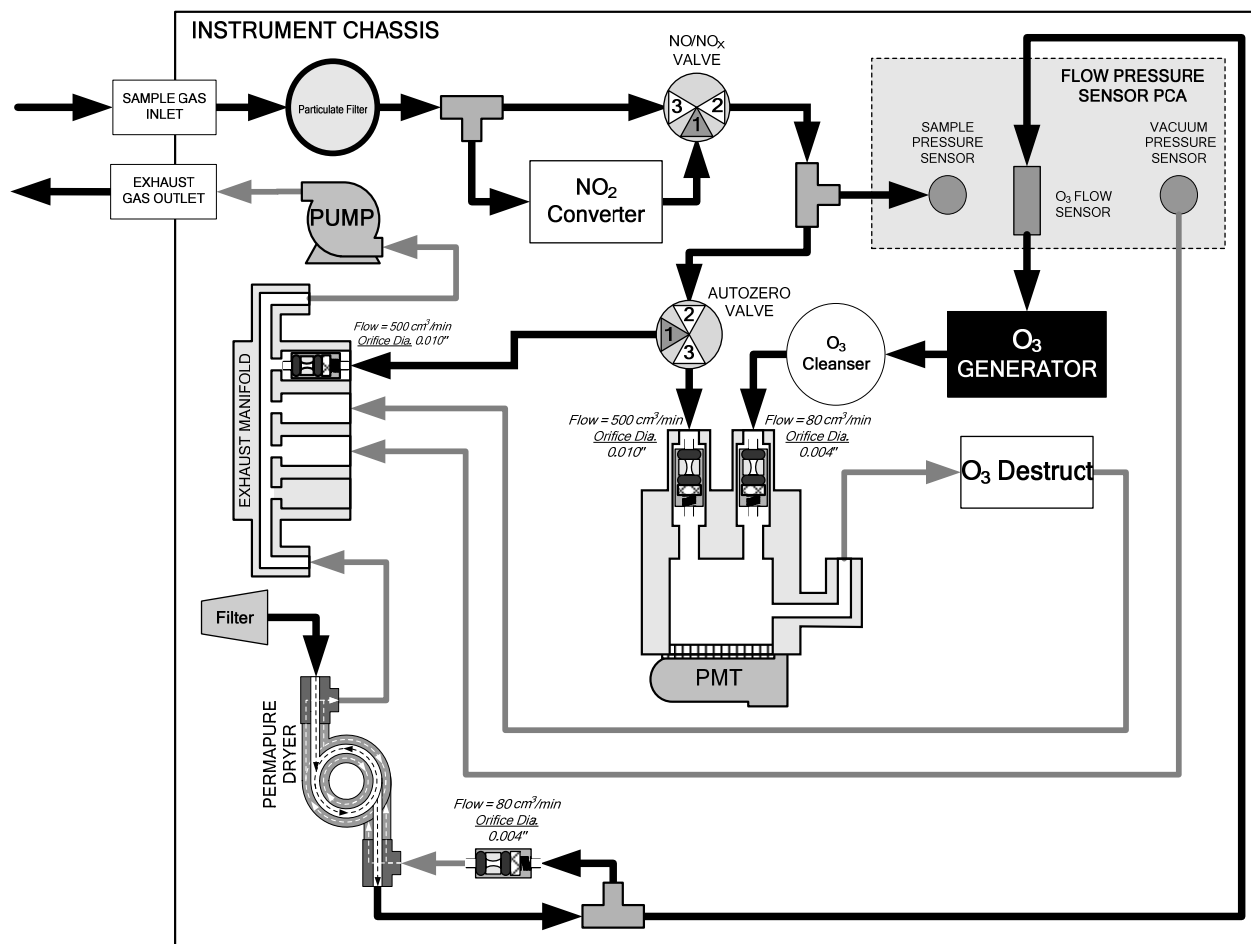

Figure 13-6: Basic Internal Gas Flow for Basic 9110T with Internal Pump

13.2.1.1. Vacuum Manifold

The vacuum created by the analyzer’s pump is supplied to all of the gas streams for the 9110T analyzer through the vacuum manifold (also called the exhaust manifold).

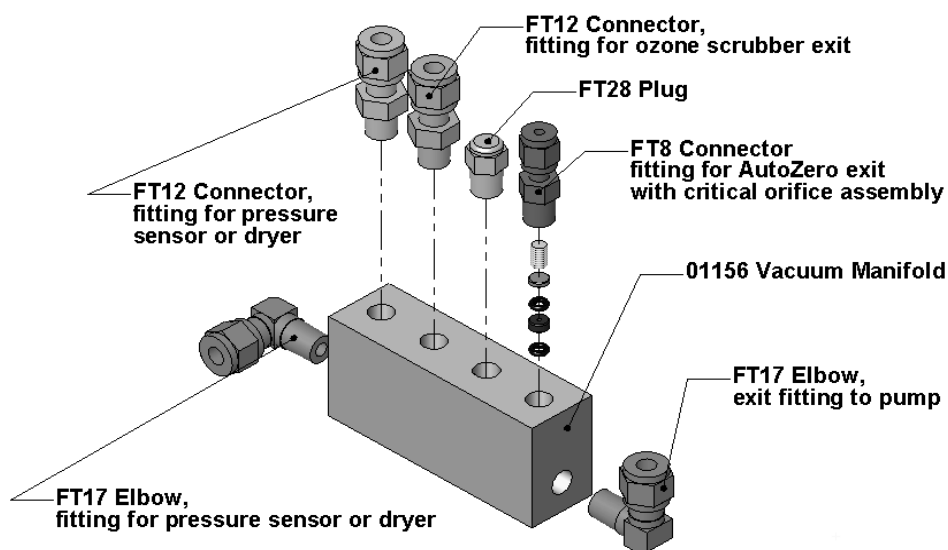

Figure 13-7. Vacuum Manifold, Standard Configuration

Configurations will vary depending on the optional equipment that is installed. For example:

- An 9110T with the optional internal span gas generator installed will add another FT8 connector and orifice assembly to the manifold where the FT28 fitting is shown in the above drawing.
- An optional sample gas dryer will add a Tee-fitting so that two ¼” tubes can be connected to the same port.

13.2.1.2. Sample Gas Flow Valves and Routing

As discussed in Section 13.1, the measurement of NO_x, NO and NO₂ requires that the sample gas flow cycles through different routes that include and exclude various scrubbers and converters. There are several valves that perform this function:

- The NO/NO_x valve directs the sample gas either directly to the reaction cell or through the unit’s NO₂ converter, alternating every ~8 sec.
- The Auto Zero valve directs the sample gas stream to completely bypass the reaction cell for dark noise measurement once every minute, which is then subtracted as a measurement offset from the raw concentration signal.

Table 13-2: 9110T Valve Cycle Phases

Phase	NO/ NO _x Valve Status	Auto Zero Valve Status	Time Index	Activity	Figure
NO Measure	Open to Auto Zero valve	Open to reaction cell	0 - 2 s	Wait period (NO dwell time). Ensures reaction cell has been flushed of previous gas.	Figure 13-3
			2 - 4 s	Analyzer measures chemiluminescence in reaction cell.	
NO _x Measure	Open to NO ₂ converter	Open to reaction cell	4 - 6 s	Wait period (NO _x dwell time). Ensures reaction cell has been flushed of previous gas.	Figure 13-3
			6 - 8 s	Analyzer measures NO + O ₃ chemiluminescence in reaction cell.	
Cycle repeats every ~8 seconds					

Auto Zero	Open to Auto Zero valve	Open to vacuum manifold	0 – 4 s	Wait period (AZERO dwell time). Ensures reaction cell has been flushed of sample gas and chemiluminescence reaction is stopped.	Figure 13-4
			4 - 6 s		
Cycle repeats every minute					

13.2.2. FLOW RATE CONTROL - CRITICAL FLOW ORIFICES

Sample gas flow in the 9110T analyzer is created via the use of several flow control assemblies (see Figure 13-8 for an example) located in various places in the gas streams of the instrument. These assemblies consist of:

- a critical flow orifice
- two o-rings, Located just before and after the critical flow orifice, the o-rings seal the gap between the walls of assembly housing and the critical flow orifice
- a sintered filter
- a spring (applies mechanical force needed to form the seal between the o-rings, the critical flow orifice and the assembly housing)

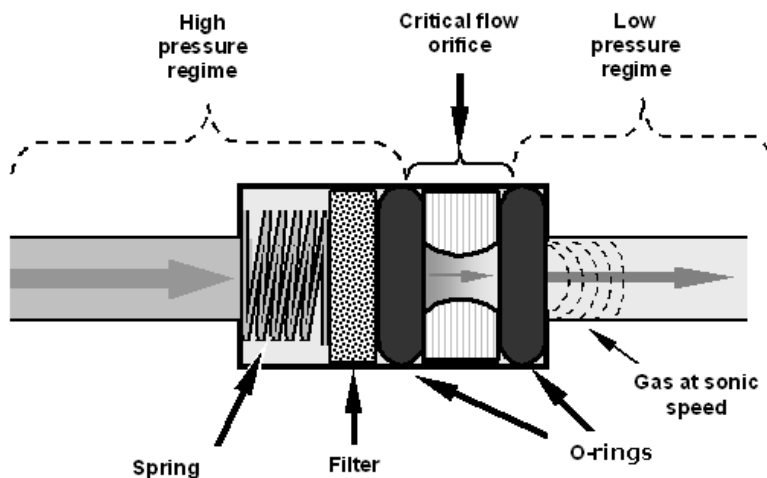

Figure 13-8: Flow Control Assembly & Critical Flow Orifice

13.2.2.1. Critical Flow Orifice

The most important component of each flow control assembly is the critical flow orifice. Critical flow orifices are a simple means to regulate stable gas flow rates. They operate without moving parts by taking advantage of the laws of fluid dynamics. By restricting the flow of gas through the orifice, a pressure differential is created. This pressure differential, created by the analyzer's external pump, draws the gas through the orifice.

As the pressure on the downstream side of the orifice (the pump side) continues to drop, the speed that the gas flows through the orifice continues to rise. Once the ratio of upstream pressure to downstream pressure is greater than 2:1, the velocity of the gas through the orifice reaches the speed of sound. As long as that ratio stays at least 2:1, the gas flow rate is unaffected by any fluctuations, surges, or changes in downstream pressure because such variations only travel at the speed of sound themselves and are therefore cancelled out by the sonic shockwave at the downstream exit of the critical flow orifice.

The actual flow rate of gas through the orifice (volume of gas per unit of time), depends on the size and shape of the aperture in the orifice. The larger the hole, the more gas molecules (moving at the speed of sound) pass through the orifice.

In addition to controlling the gas flow rates into the reaction cell, the two critical flow orifices at the inlets of the reaction cell also maintain an under-pressure inside it, effectively reducing the number of molecules in the chamber and the corresponding incidence of third body quenching (see Section 13.1.5.2) and therefore increasing the chemiluminescence yield.

- The 9110T reaches its peak sensitivity at about 2 in-Hg-A, below which the sensitivity drops due to there being too few molecules present and a corresponding decrease in chemiluminescence.

13.2.2.2. Locations and Descriptions of Critical Flow Orifices Inside the 9110T

The 9110T uses several of the following critical flow orifices (Figure 13-9) to create and maintain the proper flow rate of gas through its various components. (Please note that not all features displayed in Figure 13-9 are standard components of 9110T analyzers).

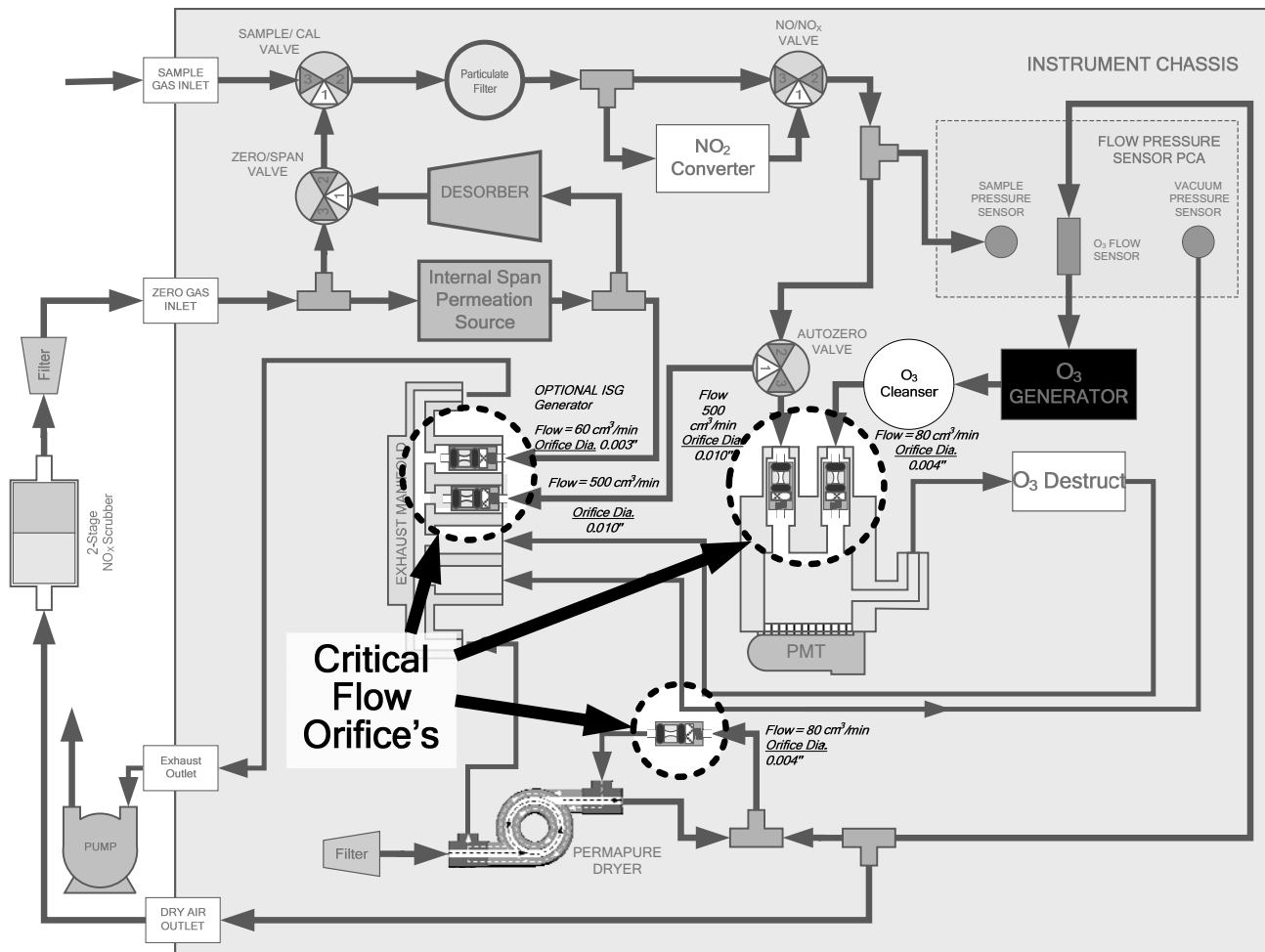

Figure 13-9: Location of Flow Control Assemblies & Critical Flow Orifices

Table 13-3: 9110T Gas Flow Rates

Location	Purpose	Orifice Diameter	Flow rate (nominal)
Sample gas inlet of reaction cell	Controls rate of flow of sample gas into the	0.010" (0.25 mm)	500 cm ³ /min

	reaction cell.		
O ₃ supply inlet of reaction cell	Controls rate of flow of ozone gas into the reaction cell.	0.004" (0.10 mm)	80 cm ³ /min
Dry air return of Perma Pure [®] dryer	Controls flow rate of dry air return / purge air of the dryer.	0.004" (0.10 mm)	80 cm ³ /min
Vacuum manifold, Auto Zero port.	Controls rate of sample gas flow when bypassing the reaction cell during the Auto Zero cycle.	0.010" (0.25 mm)	500 cm ³ /min
Vacuum manifold, Internal span gas generator exhaust port	Controls rate of flow of zero purge gas through the optional Internal span gas generator when it is installed.	0.003" (0.10 mm)	60 cm ³ /min

The necessary 2:1 ratios across the critical flow orifices is largely exceeded by the pumps supplied with the analyzer which are designed to accommodate a wide range of possible variability in atmospheric pressure and age related degradation of the pump itself. Once the pump does degrade the ratio between sample and vacuum pressures may fall to less than 2:1. At this point, the instrument will display an invalid sample flow rate measurement (XXXX).

Note

The diameter of a critical flow orifice may change with temperature because of expansion of the orifice material and, hence, the most crucial critical flow orifices in the 9110T (those controlling the sample gas and O₃ flow into the cell itself) are located in the reaction cell where they can be maintained at a constant temperature.

13.2.3. OZONE GAS GENERATION AND AIR FLOW

The excess ozone needed for reaction with NO in the reaction cell is generated inside the analyzer because of the instability and toxicity of ozone. Besides the ozone generator itself, this requires a dry air supply and filtering of the gas before it is introduced into the reaction cell.

Due to its toxicity and aggressive chemical behavior, O₃ must also be removed from the gas stream before it can be vented through the exhaust outlet.



CAUTION
GENERAL SAFETY HAZARD

Ozone (O₃) is a toxic gas.

Obtain a Material Safety Data Sheet (MSDS) for this gas. Read and rigorously follow the safety guidelines described there.

Always ensure that the plumbing of the O₃ generation and supply system is maintained and leak-free.

13.2.3.1. The O₃ Generator

The 9110T uses a dual-dielectric, Corona Discharge (CD) tube for creating its O₃, which is capable of producing high concentrations of ozone efficiently and with low excess heat (see Figure 13-10). The primary component of the generator is a glass tube with hollow walls of which the outermost and innermost surfaces are coated with electrically conductive material.

Air flows through the glass tube, between the two conductive coatings, in effect creating a capacitor with the air and glass acting as the dielectric. The layers of glass also separate the conductive surfaces from

the air stream to prevent reaction with the O_3 . As the capacitor charges and discharges, electrons are created and accelerated across the air gap and collide with the O_2 molecules in the air stream splitting them into elemental oxygen.

Some of these oxygen atoms recombine with O_2 to O_3 . The quantity of ozone produced is dependent on factors such as the voltage and frequency of the alternating current applied to the CD cells. When enough high-energy electrons are produced to ionize the O_2 molecules, a light emitting, gaseous plasma is formed, which is commonly referred to as a corona, hence the name corona discharge generator.

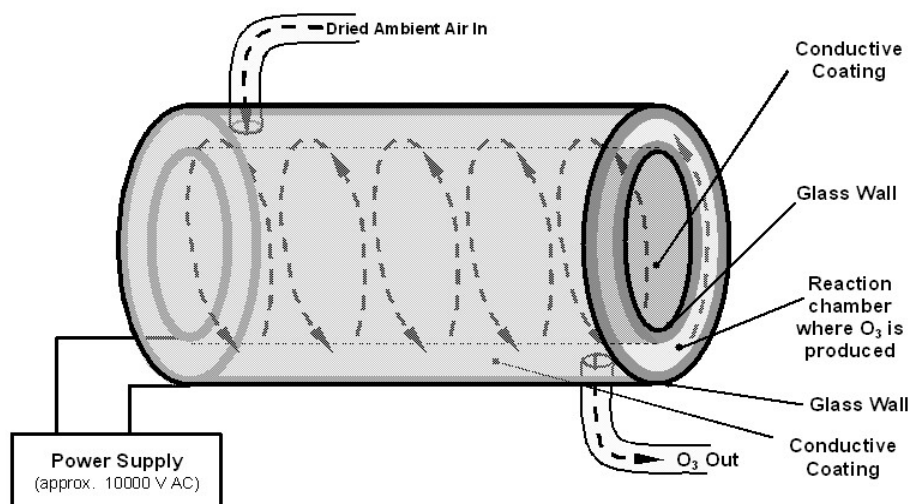

Figure 13-10: Ozone Generator Principle

13.2.3.2. Ozone Generator Dry Air Supply

Ambient air usually contains enough water vapor to greatly diminishes the yield of ozone produced by the ozone generator. Water also reacts with chemicals inside the O_3 Generator to produce caustic substances such as ammonium sulfate or highly corrosive nitric acid that will damage the optical filter located between the reaction cell and the PMT.

To prevent this, the air supply for the O_3 generator is dried using a special Perma Pure[®] single tube permeation dryer. The dryer consists of a single tube of Nafion[®] that is mounted within an outer, flexible plastic tube. Nafion[®] is a co-polymer that absorbs water very well but not most other chemicals. As gas flows through the inner Nafion[®] tube, water vapor is absorbed into the membrane walls. The absorbed water is transported through the membrane wall and evaporated into the dry purge gas flowing through the outer tube, countercurrent to the gas in the inner tube.

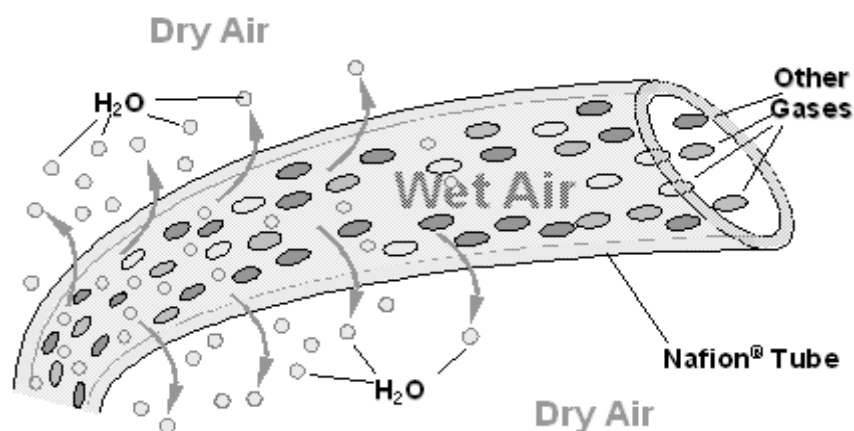

Figure 13-11: Semi-Permeable Membrane Drying Process

The process by which the water vapor molecules are collected and transported through Nafion[®] material is called per-evaporation and is driven by the humidity gradient between the inner and outer tubes as well as the flow rates and pressure difference between inner and outer tubing. Unlike micro-porous membrane permeation, which transfers water through a relatively slow diffusion process, per-evaporation is a simple kinetic reaction. Therefore, the drying process occurs quickly, typically within milliseconds.

Because this chemical reaction is based on hydrogen bonds between the water molecule and the Nafion[®] material most other chemical components of the gas to be dried are usually unaffected. Specifically, the gases of interest for the 9110T, NO and NO₂, do not get absorbed and pass the dryer unaltered.

On the other hand, other small polar gases that are capable of hydrogen bonds such as ammonia (NH₃) can be absorbed this way, too. This is an advantage since gases such as NH₃ can cause interference for the measurement of NO_x, NO and NO₂ (see Table 13-1).

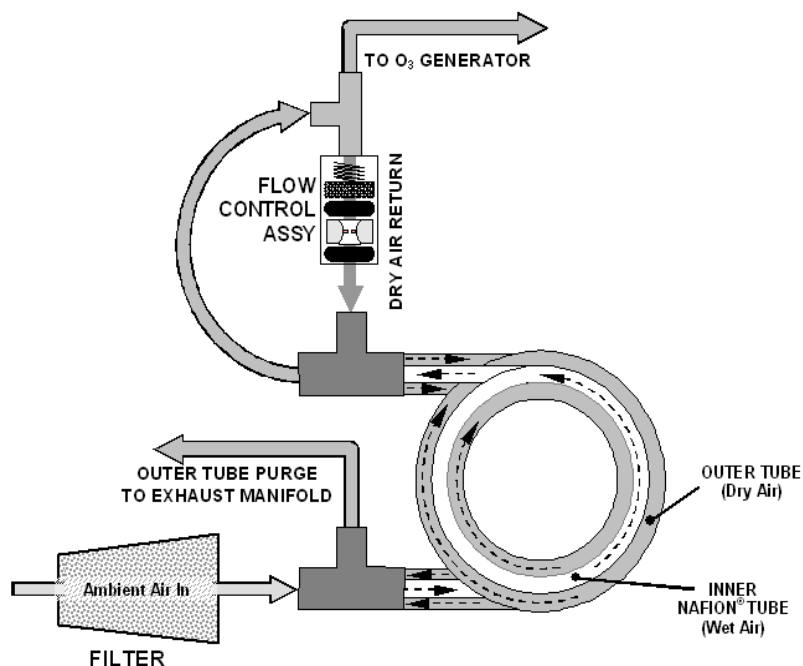

Figure 13-12: 9110T Perma Pure[®] Dryer

To provide a dry purge gas for the outer side of the Nafion tube, the 9110T returns some of the dried air from the inner tube to the outer tube. This means that any time the analyzer is turned on after having been OFF for 30 minutes or more, the humidity gradient between the inner and outer tubes is not very large and the dryer's efficiency is low. Since it takes a certain amount of time for the humidity gradient to become large enough for the Perma Pure[®] Dryer operate efficiently, in such cold start cases the O₃ Generator is not turned on until 30 minutes has passed in order to ensure that it is not operating until its air supply is properly dry. During this 30 minute duration the O3 GEN OVERRIDE menu displays "TMR" on the front panel screen.

Note

When rebooting the instrument within less than 30 minutes of power-down, the generator is turned on immediately.

The Perma Pure[®] Dryer used in the 9110T is capable of adequately drying ambient air to a dew point of $\leq -5^{\circ}\text{C}$ (~4000 ppm residual H₂O) at a flow rate of 1 standard liter per minute (slpm) or down to $\leq -15^{\circ}\text{C}$ (~1600 ppm residual H₂O) at 0.5 slpm. The Perma Pure[®] Dryer is also capable of removing ammonia from the sample gas up to concentrations of approximately 1 ppm.

13.2.3.3. Ozone Supply Air Filter

The 9110T uses ambient air as the supply gas for the O₃ generator and may produce a variety of byproducts. Small amounts of water, ammonia and various sulfur oxides can combine to create ammonium sulfate, ammonium nitrate, nitric acid and other compounds. Whereas sulfates and nitrates can create powdery residues inside the reaction cell causing sensitivity drift, nitric acid is a very aggressive compound, which can deteriorate the analyzer's components. In order to remove these chemical byproducts from the O₃ gas stream, the output of the O₃ generator flows through a special filter between the generator and the reaction cell.

The small amount of NO_x produced in the generator (from the reaction of O₂ or O₃ and N₂ in the air) will not affect the 9110T's ability to measure NO_x, NO and NO₂ as it is accounted for and removed from the concentration calculations by the analyzer's Auto Zero feature (see Section 13.1.4).

13.2.3.4. Ozone Destruct

Even though ozone is unstable and typically reacts to form O₂, the break-down is not quite fast enough to ensure that it is completely removed from the exhaust gas stream of the 9110T by the time the gas exits the analyzer. Due to the high toxicity and reactivity of O₃, a highly efficient catalytic converter scrubs or converts all of the O₃ from the gas exiting the reaction cell. The conversion process is very safe. It only converts ozone to oxygen and does not produce any toxic or hazardous gases.

The O₃ destruct is located just inside the NO₂ converter. As this is a true catalytic converter, there are no maintenance requirements as would be required for charcoal-based ozone destructs.

A certain amount of fine, black dust may exit the catalyst, particularly if the analyzer is subjected to sudden pressure drops (for example, when disconnecting the running pump without letting the analyzer properly and slowly equilibrate to ambient pressure). To prevent the dust from entering the reaction cell or the pump, the ozone destruct is equipped with a quartz wool filter material.

13.2.4. PNEUMATIC SENSORS

Note

The 9110T displays all pressures in inches of mercury absolute (in-Hg-A), i.e. absolute pressure referenced against zero (a perfect vacuum).

The 9110T uses three pneumatic sensors to verify the flow and pressure levels of its gas streams. They are located on a printed circuit assembly, called the pneumatic pressure/flow sensor board, located just behind the sensor assembly. The measurements made by these sensors are used for a variety of important calculations and diagnostics.

13.2.4.1. Sample Pressure Sensor

An absolute pressure transducer connected to the input of the NO/NO_x valve is used to measure the pressure of the sample gas before it enters the analyzer's reaction cell.

- In conjunction with the measurement made by the vacuum pressure sensor, this "upstream" measurement is used to compute the sample gas sample flow rate and to validate the critical flow condition (2:1 pressure ratio) through the sample gas critical flow orifice (Section 13.2.2).
- If the Temperature/Pressure Compensation (TPC) feature is turned on (Section 13.9.2), the output of this sensor is also used to supply pressure data for that calculation.
- The actual pressure value is viewable through the analyzer's front panel display as the test function **SAMP**.
- The flow rate of the sample gas is displayed as **SAMP FLW** and the **SIGNAL I/O** function **SAMPLE_PRESSURE**.

13.2.4.2. Vacuum Pressure Sensor

An absolute pressure transducer connected to the exhaust manifold is used to measure the pressure downstream from and inside the instrument's reaction cell.

- The output of the sensor is used by the CPU to calculate the pressure differential between the gas upstream of the reaction cell and the gas downstream from it and is also used as the main diagnostic for proper pump operation.
- If the ratio between the upstream pressure and the downstream pressure falls below 2:1, a warning message (**SAMPLE FLOW WARN**) is displayed on the analyzer's front panel (see Section 4.1.2) and the sample flow rate will display **XXXX** instead of an actual value.
- If this pressure exceeds 10 in-Hg-A, an **RCEL PRESS WARN** is issued, even though the analyzer will continue to calculate a sample flow up to ~14 in Hg.
- If the Temperature/Pressure Compensation (TPC) feature is turned on (see Section 13.9.2), the output of this sensor is also used to supply pressure data for that calculation.
- This measurement is viewable through the analyzer's front panel as the test function **RCEL** and the **SIGNAL I/O** function **RCELL_PRESSURE**.

13.2.4.3. Sample Gas Flow Calculation

Sample gas flow in the 9110T analyzer is not a directly measured value, but is rather calculated based on the measured pressure differential across the sample gas critical flow orifice. Specifically, the upstream reading of the sample pressure sensor is compared to the downstream pressure reading of the vacuum pressure sensor and this differential is used, by the analyzer's CPU, to derive the gas flow rate through the reaction cell.

- The results of this calculation are viewable from the instruments front panel via the test function **SAMP FLW**.

- Since this is a calculated value and not a measured reading there is no corresponding **SIGNAL I/O** function.

13.2.4.4. O₃ Supply Air Flow Sensor

In contrast to the sample gas flow, the ozone flow is measured with a mass flow sensor, which is mounted on the flow/pressure sensor PCA just behind the PMT sensor assembly. Pneumatically, it lies between the Perma Pure[®] dryer and the O₃. This mass flow sensor has a full scale range of 0-1000 cm³/min and can be calibrated through software to its span point (Section 9.7).

Since the flow value displayed on the front panel is an actual measurement (and not a calculated value), short term variability in the measurement may be higher than that of the sample flow, which is based on a calculation from (more stable) differential pressures. On the other hand, any sustained drift, i.e. long-term change, in the ozone flow rate may usually indicate a flow problem.

This information is used to validate the O₃ gas flow rate.

- If the flow rate exceeds $\pm 15\%$ of the nominal flow rate (80 cm³/min), a warning message **OZONE FLOW WARNING** is displayed on the analyzer's front panel (see Section 4.1.2) and the O₃ generator is turned off.
 - A second warning, **OZONE GEN OFF** is also displayed.
- This flow measurement is viewable through instrument's front panel display as the test function **OZONE FL** and the **SIGNAL I/O** function **OZONE_FLOW**.

As with all other test parameters, we recommend to monitor the ozone flow over time for predictive diagnostics and maintenance evaluation.

13.3. ELECTRONIC OPERATION

13.3.1. OVERVIEW

Figure 13-13 shows a block diagram of the major electronic components of the analyzer.

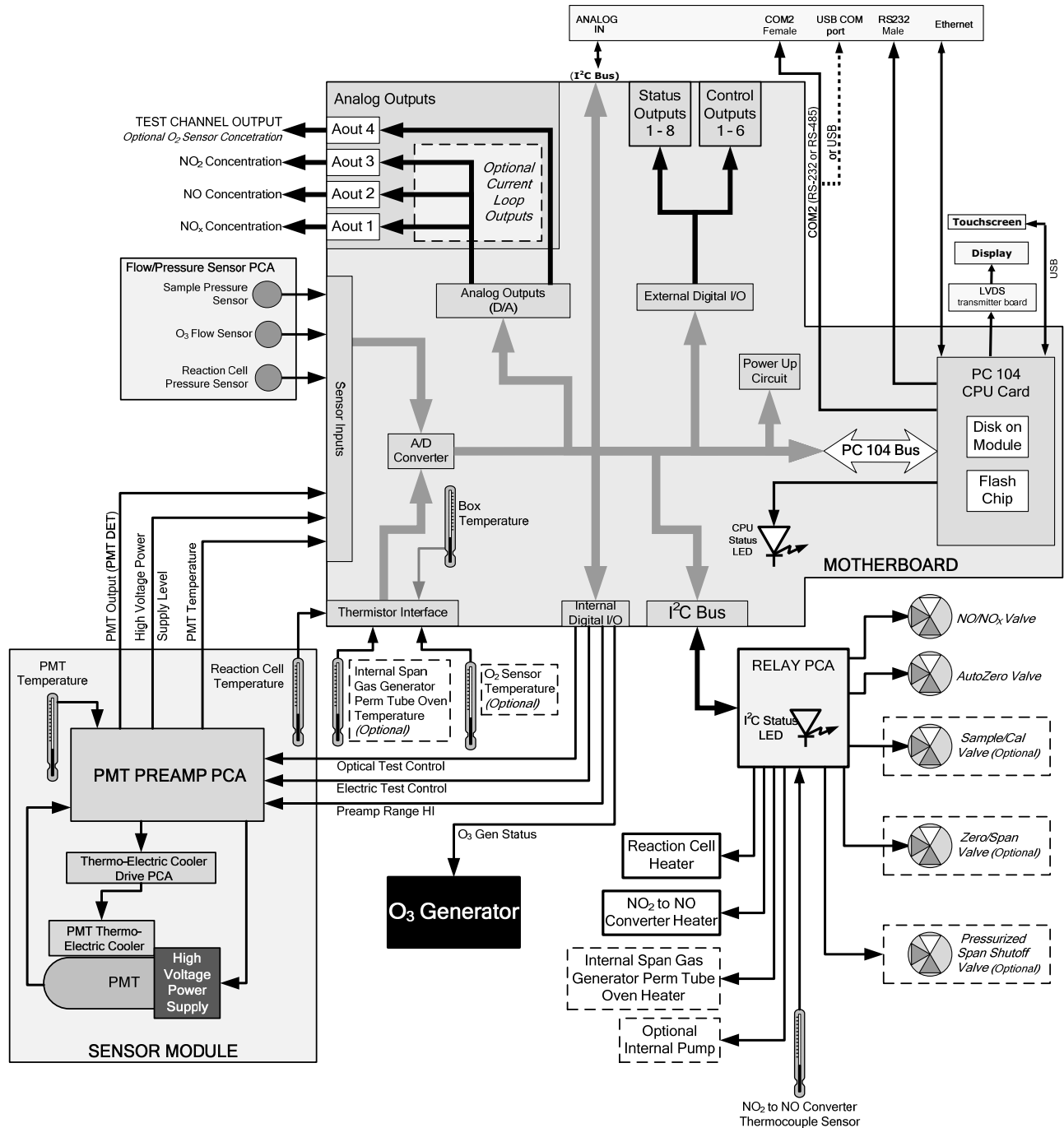

Figure 13-13: 9110T Electronic Block Diagram

The core of the analyzer is a microcomputer/central processing unit (CPU) that controls various internal processes, interprets data, makes calculations, and reports results using specialized firmware developed by Teledyne. It communicates with the user as well as receives data from and issues commands to a variety of peripheral devices via a separate printed circuit assembly onto which the CPU is mounted: the motherboard.

The motherboard is directly mounted to the inside rear panel and collects data, performs signal conditioning duties and routes incoming and outgoing signals between the CPU and the analyzer's other major components.

Data are generated by the sensor module which outputs an analog signal corresponding to the amount of chemiluminescence present in the reaction cell. This signal is converted into digital data by a unipolar, analog-to-digital converter, located on the motherboard.

A variety of sensors report the physical and operational status of the analyzer's major components, again through the signal processing capabilities of the motherboard. These status reports are used as data for the various concentration calculations and as trigger events for certain warning messages and control commands issued by the CPU. This information is stored in memory by the CPU and in most cases can be viewed by the user via the front panel display.

The CPU issues commands via a series of relays and switches (also over the I²C bus) located on a separate printed circuit assembly, called the relay PCA, to control the function of key electromechanical devices such as heaters and valves. It also issues some commands directly to the Sensor module (e.g. initiate Electric Test or Optical Test).

By controlling the state of various valves the CPU directs the flow of sample gas through the various gas paths of the analyzer (NO measurement path; NO_x measurement path; Auto Zero Path). Based on which path is active, the CPU interprets the sensor output to derive raw data representing concentrations for NO_x, NO and zero (dark condition), accesses the operational data stored in memory then calculates final concentrations for NO_x, NO and NO₂.

The CPU communicates with the user and the outside world in several ways:

- Through the analyzer's front panel LCD touch-screen interface
- Through the serial I/O channels
- Various analog voltage and current outputs
- Several sets of Digital I/O channels
- Ethernet

13.3.2. CPU

The unit's CPU card, installed on the motherboard located inside the rear panel, is a low power (5 VDC, 720mA max), high performance, Vortex86SX-based microcomputer running Windows CE. Its operation and assembly conform to the PC 104 specification.

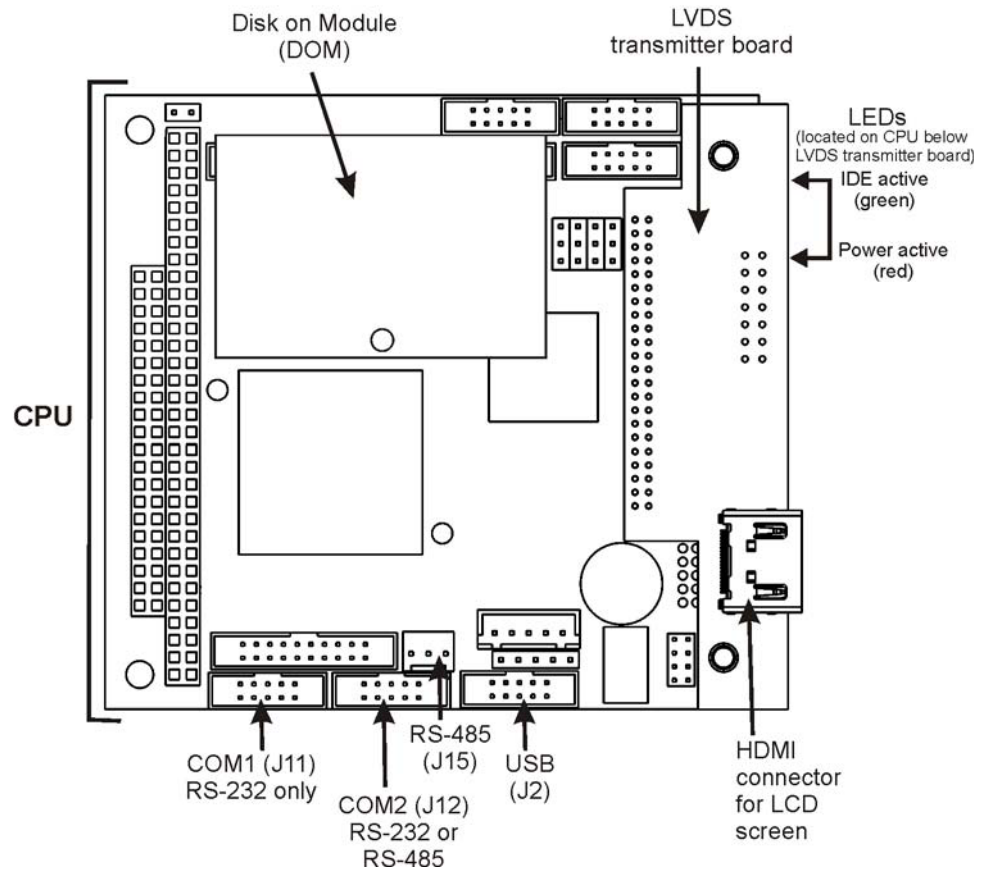

Figure 13-14: CPU Board

The CPU includes two types of non-volatile data storage: a Disk-on-Module (DOM) and an embedded flash chip.

13.3.2.1. Disk-On-Module

The DOM is a 44-pin IDE flash drive with storage capacity to 128 MB. It is used to store the computer's operating system, the Teledyne firmware, and most of the operational data generated by the analyzer's internal data acquisition system (DAS).

13.3.2.2. Flash Chip

This non-volatile, embedded flash chip includes 2MB of storage for calibration data as well as a backup of the analyzer configuration. Storing these key data on a less heavily accessed chip significantly decreases the chance of data corruption.

In the unlikely event that the flash chip should fail, the analyzer will continue to operate with just the DOM. However, all configuration information will be lost, requiring that the unit be recalibrated.

13.3.3. MOTHERBOARD

This PCA provides a multitude of functions including, A/D conversion, digital input/output, PC-104 to I²C translation, temperature sensor signal processing and is a pass through for the RS-232 and RS-485 signals.

13.3.3.1. A to D Conversion

Analog signals, such as the voltages received from the analyzers various sensors, are converted into digital signals that the CPU can understand and manipulate by the analog to digital converter (A/D). Under the control of the CPU, this functional block selects a particular signal input and then converts the selected voltage into a digital word.

The A/D consists of a Voltage-to-Frequency (V-F) converter, a Programmable Logic Device (PLD), three multiplexers, several amplifiers and some other associated devices. The V-F converter produces a frequency proportional to its input voltage. The PLD counts the output of the V-F during a specified time, and sends the result of that count, in the form of a binary number, to the CPU.

The A/D can be configured for several different input modes and ranges but in the 9110T it is used in unipolar mode with a +5V full scale. The converter includes a 1% over and under-range. This allows signals from -0.05V to +5.05V to be fully converted.

For calibration purposes, two reference voltages are supplied to the A/D converter: Reference ground and +4.096 VDC. During calibration, the device measures these two voltages, outputs their digital equivalent to the CPU. The CPU uses these values to compute the converter's offset and slope and uses these factors for subsequent conversions. See Section 5.9.3.10 for instructions on performing this calibration.

13.3.3.2. Sensor Inputs

The key analog sensor signals are coupled to the A/D through the master multiplexer from two connectors on the motherboard. 100K terminating resistors on each of the inputs prevent cross talk from appearing on the sensor signals.

PMT DETECTOR OUTPUT: The PMT detector output from the PMT preamplifier is used in the computation of the NO, NO_x and NO₂ concentrations displayed on the front panel display and reported through the instrument's analog outputs and COMM ports.

This information is available in several forms:

- As a raw voltage signal via the test function **PMTDET** and the SIGNAL I/O function **PMT_SIGNAL**, or;
- Normalized for temperature, pressure and auto-zero offset via the front panel test function **NORM PMT**.
- It is recorded by the DAS system in the following parameters:
 - **PMTDET** – The same as the test function **PMT DET**.
 - **RAWNOX** – The raw PMT output when the instrument is measuring NO_x.
 - **RAW NO** – The raw PMT output when the instrument is measuring NO.

HIGH VOLTAGE POWER SUPPLY LEVEL: The PMT high voltage is based on the drive voltage from the preamplifier board. It is digitized and sent to the CPU where it is used to calculate the voltage setting of the HVPS.

- The value of this signal is viewable via the front panel test function HVPS and the SIGNAL I/O function HVPS_VOLTAGE.
- It is recorded by the DAS system as the parameter **HVPS**.

PMT TEMPERATURE: The PMT temperature is measured with a thermistor inside the PMT cold block. Its signal is amplified by the PMT temperature feedback circuit on the preamplifier board and is digitized and sent to the CPU where it is used to calculate the current temperature of the PMT.

- The value of this signal is viewable via the front panel test function **PMT TEMP** and the SIGNAL I/O function **PMT_TEMP**.
- It is recorded by the DAS system as the parameter **PMTTMP**.

SAMPLE GAS PRESSURE SENSOR: This sensor, located on the flow/pressure sensor PCA, measures the gas pressure in the sample chamber upstream of the sample gas stream flow control assembly. Its functions are described in Section 13.2.4.1.

- The value of this signal is viewable via the front panel test function **SAMP** and the SIGNAL I/O function **SAMPLE_PRESSURE**.
- It is recorded by the DAS system as the parameter **SMPPRS**.

VACUUM PRESSURE SENSOR: This sensor, also located on the flow/pressure sensor PCA, is pneumatically located downstream from the reaction cell and measures the pressure of the gas mixture inside the reaction cell. Its functions are described in Section 13.2.4.2.

- The value of this signal is viewable via the front panel test function **RCEL** and the SIGNAL I/O function **RCEL_PRESSURE**.
- It is recorded by the DAS system as the parameter **RCPRES**.

O₃ FLOW SENSOR: This sensor, located on the flow/pressure sensor PCA, measures the flow rate of the O₃ gas stream as it is supplied to the reaction cell. Its functions are described in Section 13.2.4.4.

- The value of this signal is viewable via the front panel test function **OZONE FLOW** and the SIGNAL I/O function **OZONE_FLOW**.
- It is recorded by the DAS system as the parameter **O3FLOW**.

13.3.3.3. Thermistor Interface

This circuit provides excitation, termination and signal selection for several negative coefficient, thermistor temperature sensors located inside the analyzer. They are:

REACTION CELL TEMPERATURE SENSOR: The reaction cell temperature sensor is a thermistor embedded in the reaction cell manifold. This temperature is used by the CPU to control the reaction cell heating circuit and as a parameter in the temperature/pressure compensation algorithm.

- The value of this signal is viewable via the front panel test function **RCEL TEMP** and the SIGNAL I/O function **RCELL_TEMP**.
- It is recorded by the DAS system as the parameter **RCTEMP**.

BOX TEMPERATURE SENSOR: A thermistor is attached to the motherboard. It measures the analyzer's inside temperature. This information is stored by the CPU and can be viewed by the user for troubleshooting purposes through the front panel display. It is also used as part of the NO, NO_x and NO₂ calculations when the instrument's Temperature/Pressure Compensation feature is enabled.

- The value of this signal is viewable via the front panel test function **BOX TEMP** and the SIGNAL I/O function **BOX_TEMP**.
- It is recorded by the DAS system as the parameter **BOXTMP**.

INTERNAL SPAN GAS GENERATOR OVEN_TEMPERATURE: This thermistor reports the temperature of the optional internal span gas generator's NO₂ permeation source to the CPU as part of a control loop that keeps the tube at a high constant temperature (necessary to ensure that the permeation rate of NO₂ is constant). It is stored and reported as test function **IZS TEMP**.

- The value of this signal is viewable via the front panel test function **IZS TEMP** and the SIGNAL I/O function **IZS_TEMP**.
- It is recorded by the DAS system as the parameter **IZTEMP**.

Note

There are two thermistors that monitor the temperature of the PMT assembly:

One is embedded in the cold block of the PMT's TEC. Its signal is conditioned by the PMT preamplifier PCA and reported to the CPU via the motherboard (see Section 13.3.3.2).

The second is located on the PMT Preamplifier PCA and is used only as a reference for the preamplifier circuitry. Its output is neither reported nor stored.

13.3.3.4. Analog Outputs

The analyzer comes equipped with four analog outputs. On the instrument's rear panel analog connector (see Figure 3-4), they are labeled **A1**, **A2**, **A3** and **A4**.

CONCENTRATION OUTPUTS: Outputs labeled **A1**, **A2** and **A3** carry the concentration signals of NO_x, NO and NO₂, respectively. A variety of scaling measurement and electronic factors apply to these signals.

- See Sections 3.3.1.3 and 5.4 for information on setting the reporting range type and measurement range scaling factors for these output channels.
- See Sections 5.9.3.2 for instructions calibrating and scaling the electronic output of these channels.

TEST OUTPUT: The fourth analog output, labeled **A4** is special. It can be set by the user (see Section 5.9.4) to carry the current signal level of most of the parameters accessible through the **TEST** menu of the unit's software.

- In its standard configuration, the 9110T comes with all four of these channels set up to output a DC voltage. However, 4-20mA current loop drivers can be purchased for the first three of these outputs, **A1**, **A2** and **A3**.

OUTPUT LOOP-BACK: All of the functioning analog outputs are connected back to the A/D converter through a Loop-back circuit. This permits the voltage outputs to be calibrated by the CPU without need for any additional tools or fixtures (see Section 5.9.3.4).

13.3.3.5. External Digital I/O

This external digital I/O performs two functions.

STATUS OUTPUTS: Logic-Level voltages (0-5 VDC) are output through an optically isolated 8-pin connector located on the rear panel of the analyzer (see Figure 3-4). These outputs convey good/bad and on/off information about certain analyzer conditions. They can be used to interface with certain types of programmable devices.

- For information on setting up the status outputs (see Section 3.3.1.4).

CONTROL INPUTS: By applying 5V DC power to these digital inputs from an external source such as a PLC or Data logger zero point and span point calibrations can be remotely initiated. .

- For information on setting up the status inputs (see Section 3.3.1.6).

13.3.3.6. Internal Digital I/O

There are several internal digital control signals that are generated by the motherboard under CPU control and used to control subsystems of the analyzer.

ELECTRICAL TEST CONTROL: When the CPU sets this control signal to high (**ON**) the electric test feature (**ETEST**) is initiated (see Section 8.3).

- The **ETEST** can be initiated by following the procedure in Section 12.7.12.2, or by setting the SIGNAL I/O Function **ELEC_TEST** to **ON**.

OPTICAL TEST (OTEST) CONTROL: When the CPU sets this control signal to high (**ON**) the optical test feature is initiated (see Section 8.3).

- The **OTEST** can be initiated by following the procedure in 12.7.12.1, or by setting the SIGNAL I/O Function **OPTIC_TEST** to **ON**.

PMT PREAMPLIFIER RANGE CONTROL: The CPU uses this control switch the instrument between its LOW and HIGH physical ranges (see Section 5.4.1).

- The instrument can be forced into its HIGH physical range setting the SIGNAL I/O function **PREAMP_RANGE_HI** to **ON**.

O₃ GEN STATUS: The CPU uses this control signal to turn the O₃ generator **ON/OFF** by setting it to HIGH/LOW respectively. The CPU turns **OFF** the O₃ generator if there is no or low air flow to it as measured by the O₃ flow sensor or if the instrument has been turned off for more than 30 minutes.

- The O₃ generator can be manually turned **ON/OFF** by using the **OZONE GENERATOR OVERRIDE** feature (See Section 12.7.15.1) or by setting the SIGNAL I/O function **O3GEN_STATUS** to **ON** or **OFF**.

Note

Any I/O signals changed while in the signal I/O menu will remain in effect ONLY until signal I/O menu is exited.

The analyzer regains control of these signals upon exit and returns them to their normal value/setting.

13.3.3.7. I²C Data Bus

I²C is a two-way, clocked, bi-directional digital serial I/O bus that is used widely in commercial and consumer electronic systems. A transceiver on the Motherboard converts data and control signals from the PC-104 bus to I²C format. The data is then fed to the relay board, optional analog input board and valve driver board circuitry.

13.3.3.8. Power-Up Circuit

This circuit monitors the +5V power supply during start-up and sets the analog outputs, external digital I/O ports, and I²C circuitry to specific values until the CPU boots and the instrument software can establish control.

13.3.4. RELAY PCA

The CPU issues commands via a series of relays and switches located on a separate printed circuit assembly, called the relay PCA, to control the function of key electromechanical devices such as heaters and valves. The relay PCA receives instructions in the form of digital signals over the I²C bus, interprets these digital instructions and activates its various switches and relays appropriately.

The relay PCA is located in the right-rear quadrant of the analyzer and is mounted vertically on the backside of the same bracket as the instrument's DC power supplies.

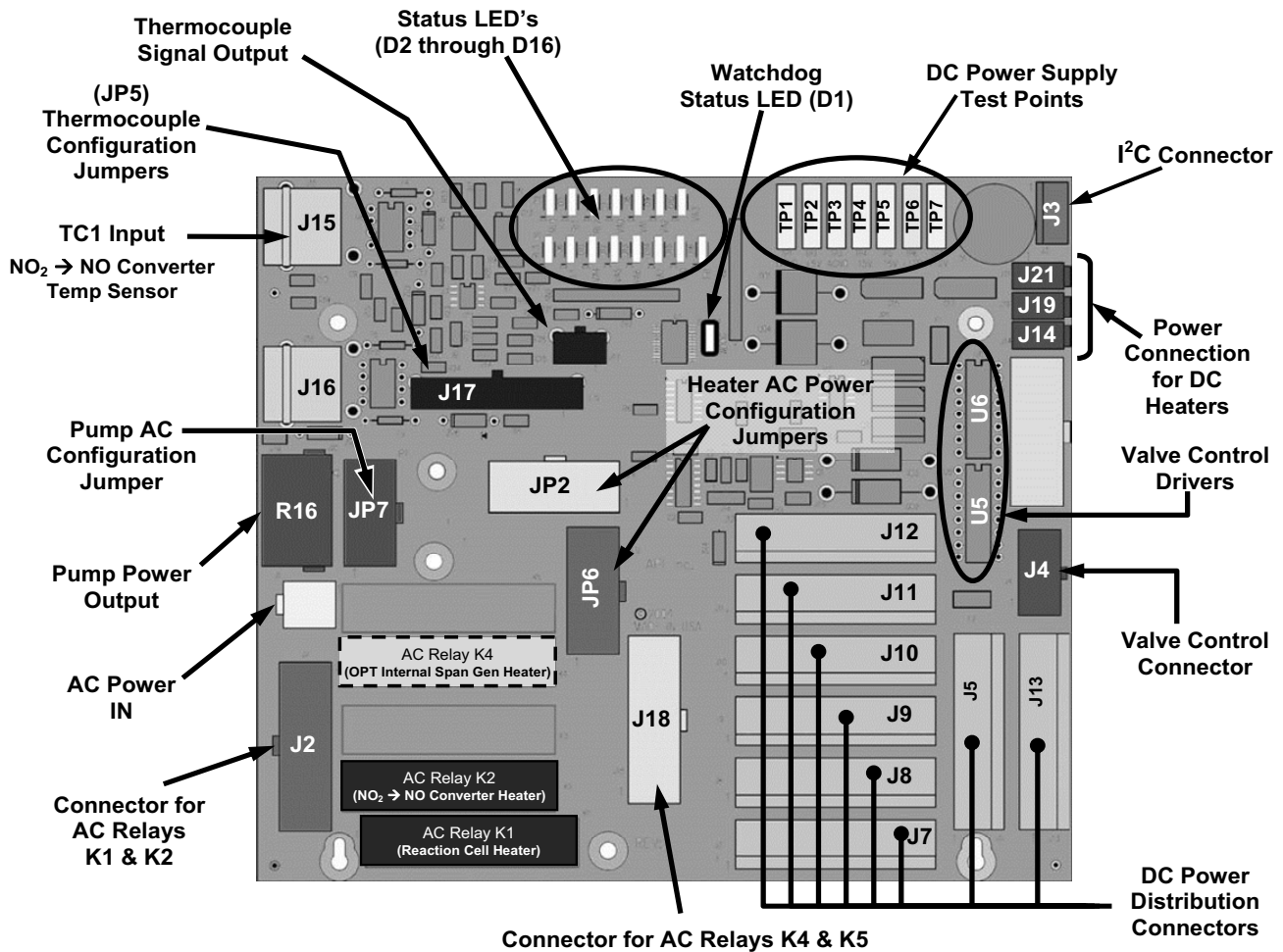



Figure 13-15: Relay PCA Layout (P/N 045230100)



CAUTION
ELECTRICAL SHOCK HAZARD

Only those relays actually required by the configuration of the 9110T are populated.
 A protective retainer plate is installed over the ac power relay to keep them securely

seated in their sockets and prevent accidental contact with those sockets that are not populated see Figure 13-16).

Never remove this retainer while the instrument is plugged in and turned on. The contacts of the AC relay sockets beneath the shield carry high AC voltages even when no relays are present.

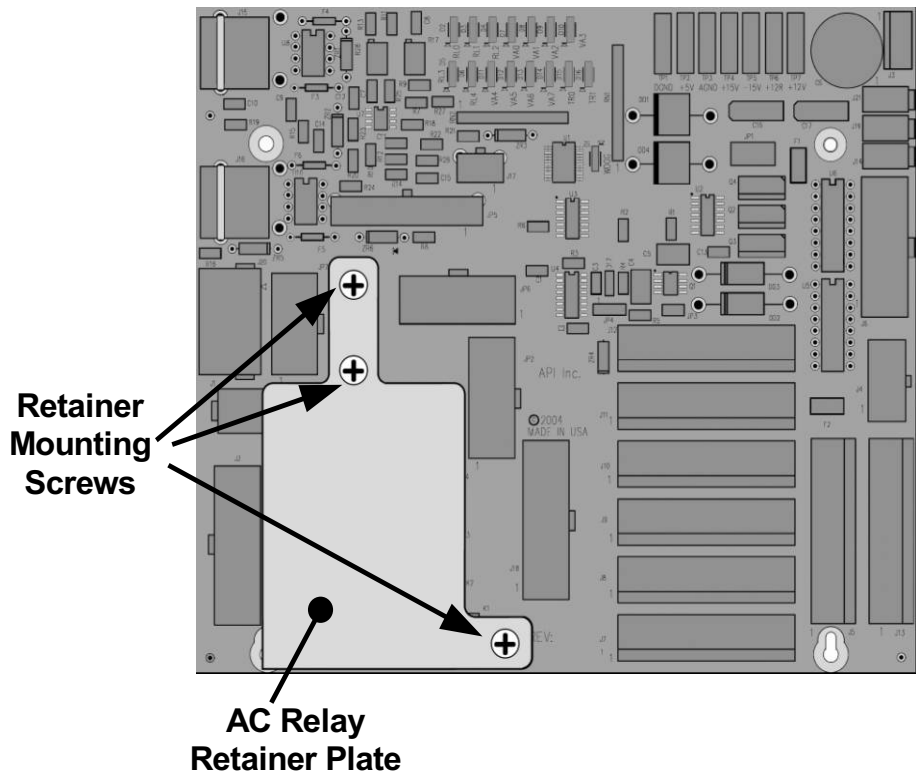

Figure 13-16: Relay PCA P/N 045230100 with AC Relay Retainer in Place

13.3.4.1. Status LED's

Eight LED's are located on the analyzer's relay PCA to show the current status on the various control functions performed by the relay PCA (see Figure 13-17). They are:

Table 13-4: Relay PCA Status LED's

LED	Color	Function	Status When Lit (Energized State)	Status When Unlit (Default State)
D1	Red	Watchdog Circuit	Cycles ON/OFF every 3 Seconds under direct control of the analyzer's CPU.	
D2	Yellow	Reaction Cell Heater	Heating	Not Heating
D3	Yellow	NO ₂ → NO Converter Heater	Heating	Not Heating
D4	SPARE			
D5 ¹	Yellow	Internal Span Gas Generator Perm Tube Oven Heater	Heating	Not Heating
D6	SPARE			
D7	Green	Zero/Span Valve	Valve OPEN to span gas flow	Valve OPEN to zero gas flow
D8	Green	Sample/Cal Valve	Valve OPEN to calibration gas flow	Valve OPEN to sample gas flow
D9	Green	Auto Zero Valve	Sample gas flow BYPASSES the reaction cell	Sample gas flow is routed THROUGH the reaction cell
D10	Green	NO/NO _x Valve	Gas flow routed THROUGH NO ₂ → NO converter	Gas Flow BYPASSES NO ₂ → NO converter
D11 ²	Green	Dual Span Gas Select Valve	Valve OPEN to SPAN 1 gas inlet	Valve OPEN to SPAN2 inlet
D12 ³	Green	Pressurized Span Shutoff Valve	Span gas flow SHUTOFF	Span gas flow OPEN
D13 ⁴	Green	Pressurized Zero Shutoff Valve	Zero gas flow SHUTOFF	Zero gas flow OPEN
D14 - 16	SPARE			
¹ Only active when the optional internal span gas generator is installed. ² Only active when the dual pressurized span option is installed. ³ Only active when one of the pressurized span gas options is installed. ⁴ Only active when one the pressurized zero gas option is installed.				

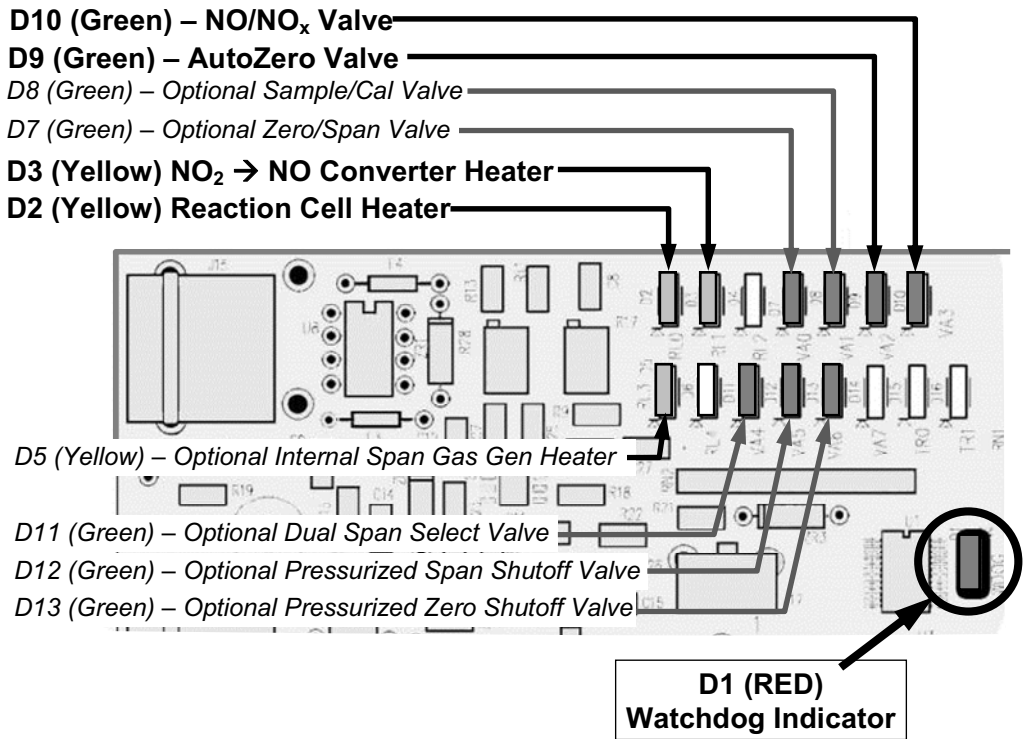

Figure 13-17: Status LED Locations – Relay PCA

13.3.4.2. Watchdog Circuitry

The most important of the status LED’s on the relay board is the red I²C bus watch-dog LED. It is controlled directly by the analyzer’s CPU over the I²C bus. Special circuitry on the relay PCA watches the status of D1. Should this LED ever stay ON or OFF for 30 seconds, indicating that the CPU or I²C bus has stopped functioning, this Watchdog Circuit automatically shuts all valves and turns off all heaters.

13.3.4.3. Valve Control

The relay board also hosts two valve driver chips, each of which can drive up four valves. The main valve assembly in the 9110T is the NO/NO_x - Auto-zero solenoid valve component mounted right in front of the NO₂ converter housing (see Figure 3-5).

- These two valves are actuated with 12 V supplied from the relay board and under the control of the CPU through the I²C bus.

Additional valve sets also controlled by the CPU via the I²C bus and the relay PCA can be included in the 9110T (see Table 1-1 and Sections 3.3.2.3, 3.3.2.4, and 3.3.2.5 for descriptions of these valve sets).

13.3.4.4. Heater Control

For a variety of reasons such as, efficiency of certain chemical reactions, stabilization of sample gas temperature and pressure, etc., various subcomponents of the 9110T are heated/cooled.

Two types of sensors are used to gather temperature data for the CPU:

- **THERMISTORS:** These are used in areas where the temperature control point is at or near ambient temperature (e.g. the reaction cell temperature, internal chassis temperate).
 - Thermistors change resistance as they heat up and cool down. A DC signal is sent from the Mother board of a sent voltage and current. As the thermistor changes resistance, the returning voltage rises and falls in direct relationship to the change in temperature.
 - The output signal from the thermistors is received by the motherboard, converted into digital data which is forwarded to the CPU.

- **THERMOCOUPLES:** These are used where the target temperature is high such as the NO₂ → NO converter.
 - Thermocouples generate DC voltage that rises and falls as the thermocouple heats up and cools down.
 - This DC signal interpreted, conditioned and amplified by the Relay PCA then transmitted to the motherboard where it is also converted into digital data and forwarded to the CPU.

All of the heaters used in the 9110T are AC powered which are turned ON/OFF by AC Relays located on the relay PCA in response to commands issued by the CPU.

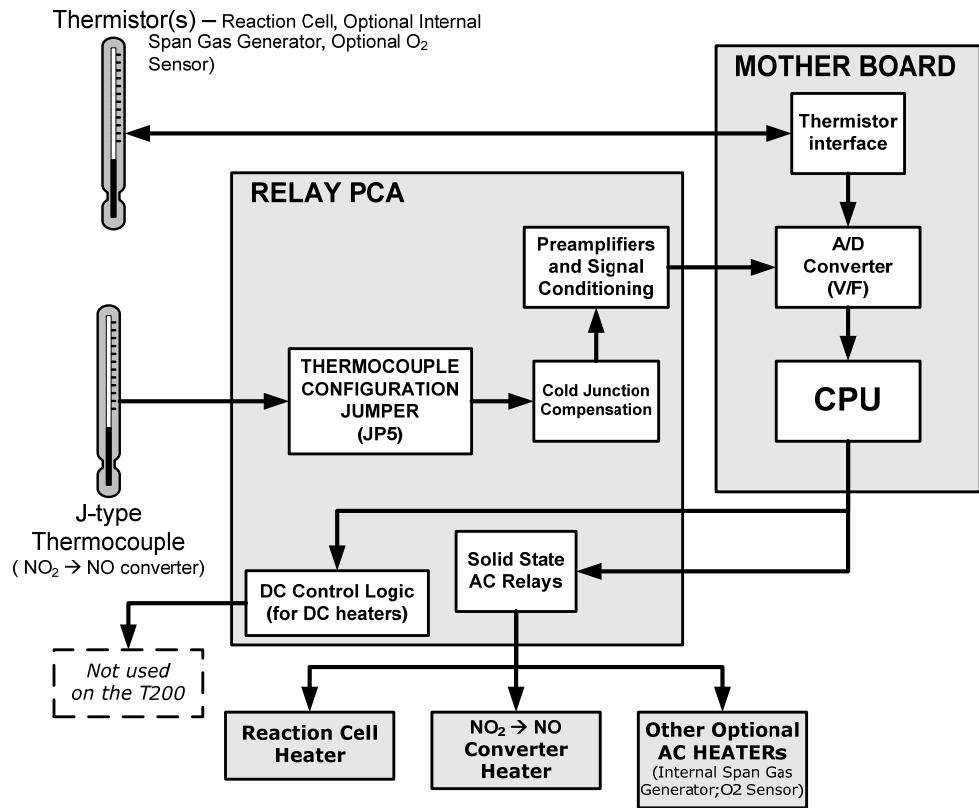

Figure 13-18: Heater Control Loop Block Diagram.

Note

The PMT temperature is maintained by a separate control loop that does not involve the relay PCA (see Section 13.5.2).

13.3.4.5. Thermocouple Inputs and Configuration Jumper (JP5)

Although the relay PCA supports two thermocouple inputs, the current 9110T analyzers only utilize one. It is used to sense the temperature of the NO₂ → NO converter.

- This single thermocouple input is plugged into the TC1 input (J15).
- TC2 (J16) is currently not used (see Figure 13-15 for location of J15 and J16).

The type and operating parameters of this thermocouple are set using a jumper plug (JP5).

The default configuration for this thermocouple is:

- Type-K
- Temperature compensated for Type-K
- Isolated

Table 13-5: Thermocouple Configuration Jumper (JP5) Pin-Outs

TC INPUT	JUMPER PAIR	DESCRIPTION	FUNCTION
TC1	1 – 11	Gain Selector	Selects preamp gain factor for J or K TC OUT = K TC gain factor; <i>IN = J TC gain factor</i>
	2 – 12	Output Scale Selector	Selects preamp gain factor for J or K TC <i>OUT = 10 mV / °C; IN = 5 mV / °C</i>
	3 – 13	Type J Compensation	When present, sets Cold Junction Compensation for J type Thermocouple
	4 – 14	Type K Compensation	When present, sets Cold Junction Compensation for K type Thermocouple
	5 – 15	Termination Selector	Selects between Isolated and grounded TC IN = Isolate TC; <i>OUT = Grounded TC</i>
TC2	NOT USED		

ATTENTION

COULD DAMAGE INSTRUMENT AND VOID WARRANTY
The correct Thermocouple Type must be used if there is ever the need for replacement. If in doubt please consult Teledyne Customer Service.

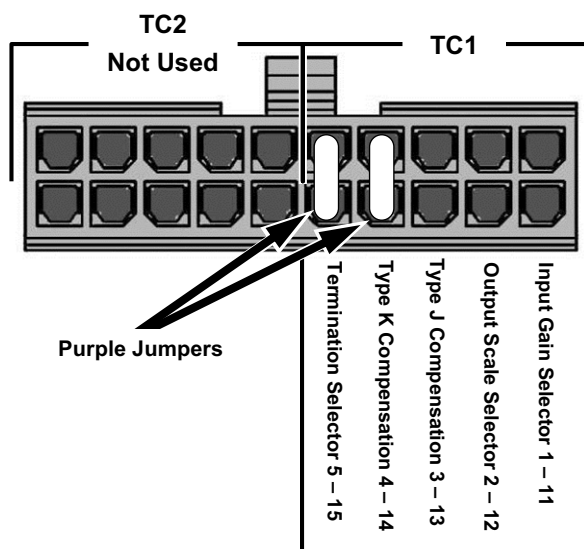

Figure 13-19: Thermocouple Configuration Jumper (JP5) Pin-Outs

13.4. SENSOR MODULE, REACTION CELL

The 9110T sensor assembly consists of several subassemblies, each with different tasks:

- The Photo Multiplier Tube (PMT) detects the intensity of the light from the chemiluminescence reaction between NO and O₃ in the reaction cell. It outputs a current signal that varies in relationship with the amount of light in the reaction cell.
- The PMT Preamplifier PCA converts the current output by the PMT into a voltage and amplifies it to a signal strong enough to be usable by the motherboard's A → D converter.
- It also supplies the drive voltage and gain adjustment for the PMT's High Voltage Power Supply (HVPS)
- The Thermo-Electric Cooler (TEC) controls the temperature of the PMT to ensure the accuracy and stability of the measurements.

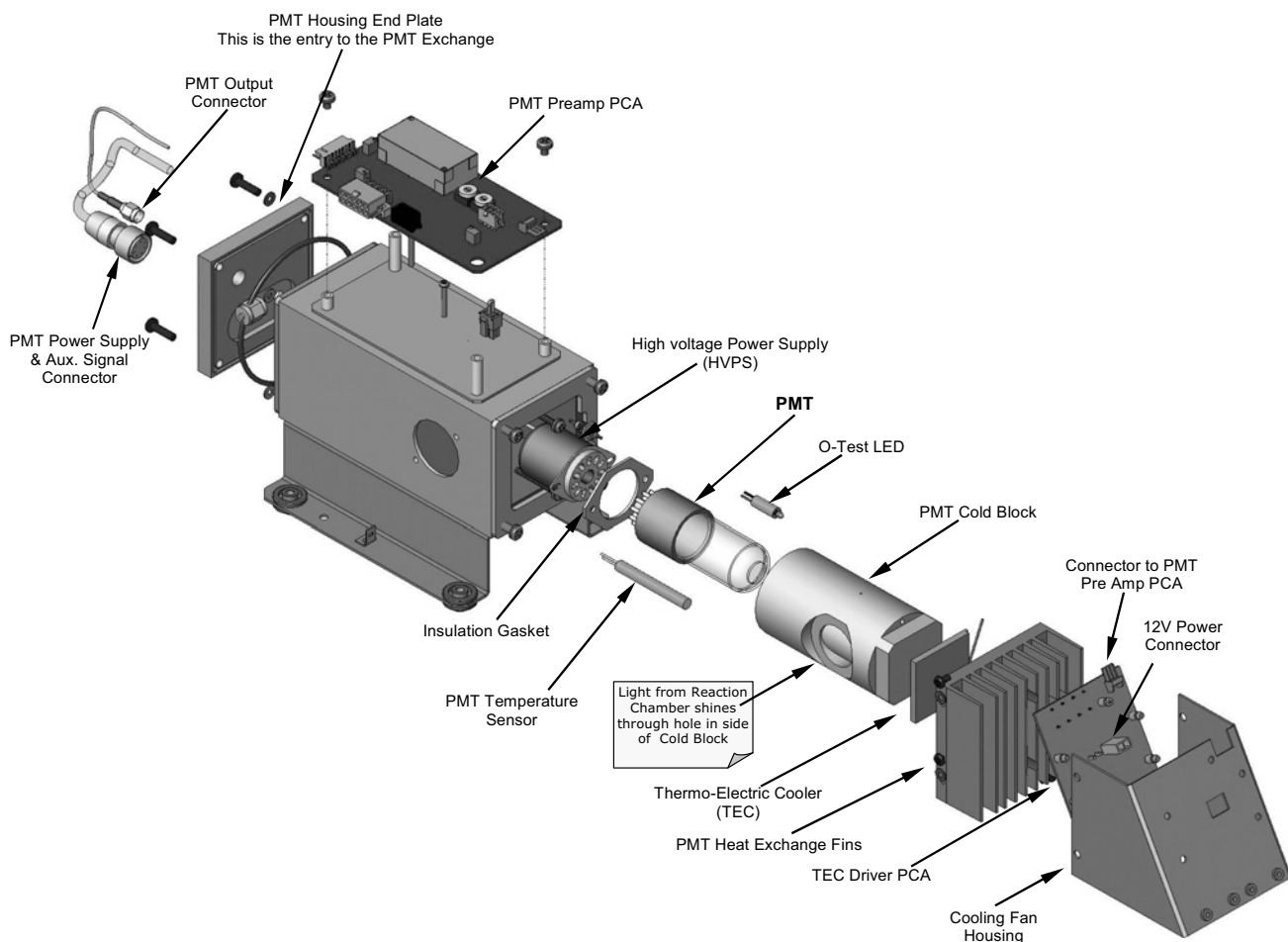

Figure 13-20: 9110T Sensor Module Assembly

13.5. PHOTO MULTIPLIER TUBE (PMT)

The 9110T uses a photo multiplier tube (PMT) to detect the amount of chemiluminescence created in the Reaction Cell.

A typical PMT is a vacuum tube containing a variety of specially designed electrodes. Photons from the reaction are filtered by an optical high-pass filter, enter the PMT and strike a negatively charged photo cathode causing it to emit electrons. A high voltage potential across these focusing electrodes directs the electrons toward an array of high voltage dynodes.

The dynodes in this electron multiplier array are designed so that each stage multiplies the number of emitted electrons by emitting multiple, new electrons. The greatly increased number of electrons emitted from one end of electron multiplier are collected by a positively charged anode at the other end, which creates a useable current signal. This current signal is amplified by the preamplifier board and then reported to the motherboard.

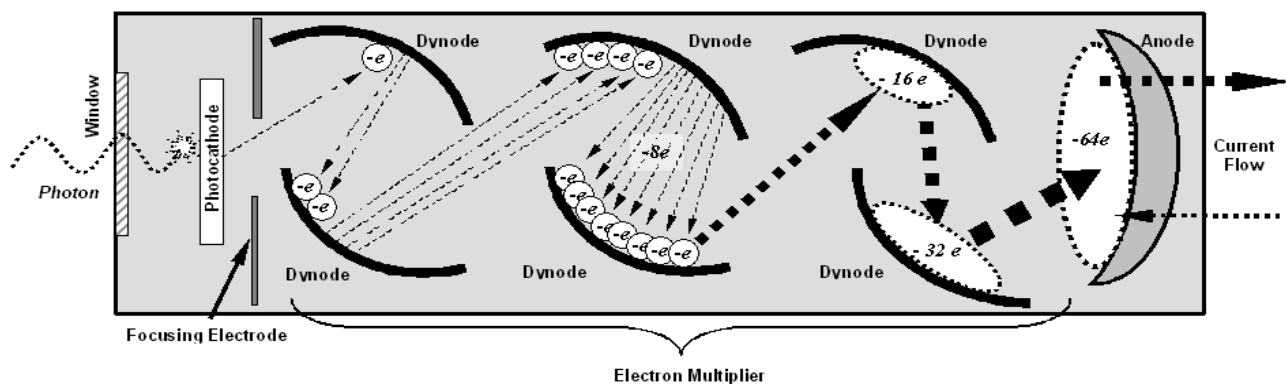

Figure 13-21: Basic PMT Design

A significant performance characteristic of the PMT is the voltage potential across the electron multiplier. The higher the voltage, the greater the number of electrons emitted from each dynode of the electron multiplier, in effect, making the PMT more sensitive and responsive to smaller variations in light intensity but also more noisy (this is referred to as “dark noise”).

- The gain voltage of the PMT used in the 9110T is usually set between 400 V and 800 V.
- This parameter is viewable through the front panel as test function **HVPS** (see Section 4.1.1).
- For information on when and how to set this voltage, see Section 12.8.4.

The PMT is housed inside the PMT module assembly (see Figure 13-20). This assembly also includes the high voltage power supply required to drive the PMT, an LED used by the instrument’s optical test function, a thermistor that measures the temperature of the PMT and various components of the PMT cooling system including the TEC.

13.5.1. PMT PREAMPLIFIER

The PMT preamplifier board provides a variety of functions:

- It amplifies the PMT signal into a useable analog voltage (**PMTDET**) that can be processed by the motherboard into a digital signal to be used by the CPU to calculate the NO, NO₂ and NO_x concentrations of the gas in the sample chamber.
- It supplies the drive voltage for the HVPS.
- It includes the circuitry for switching between the two physical ranges.
- It amplifies the signal output by the PMT temperature sensor and feeds it back to the thermoelectric cooler driver PCA. This amplified signal is also sent to the Motherboard to be digitized and forwarded to the CPU. It is viewable via the front panel as the test function **PMT TEMP**.
- It provides means for adjusting the electronic signal output from the PMT by:
 - Adjusting this voltage directly the sensitivity of the PMT’s dynode array and therefore the strength of the signal output by the PMT through the use of two hexadecimal switches.
 - Directly adjusting the gain of the output signal.

Note

These adjustments should only be performed when encountering problems with the software calibration that cannot be rectified otherwise. See Section 12.8.4 for more information about this hardware calibration.

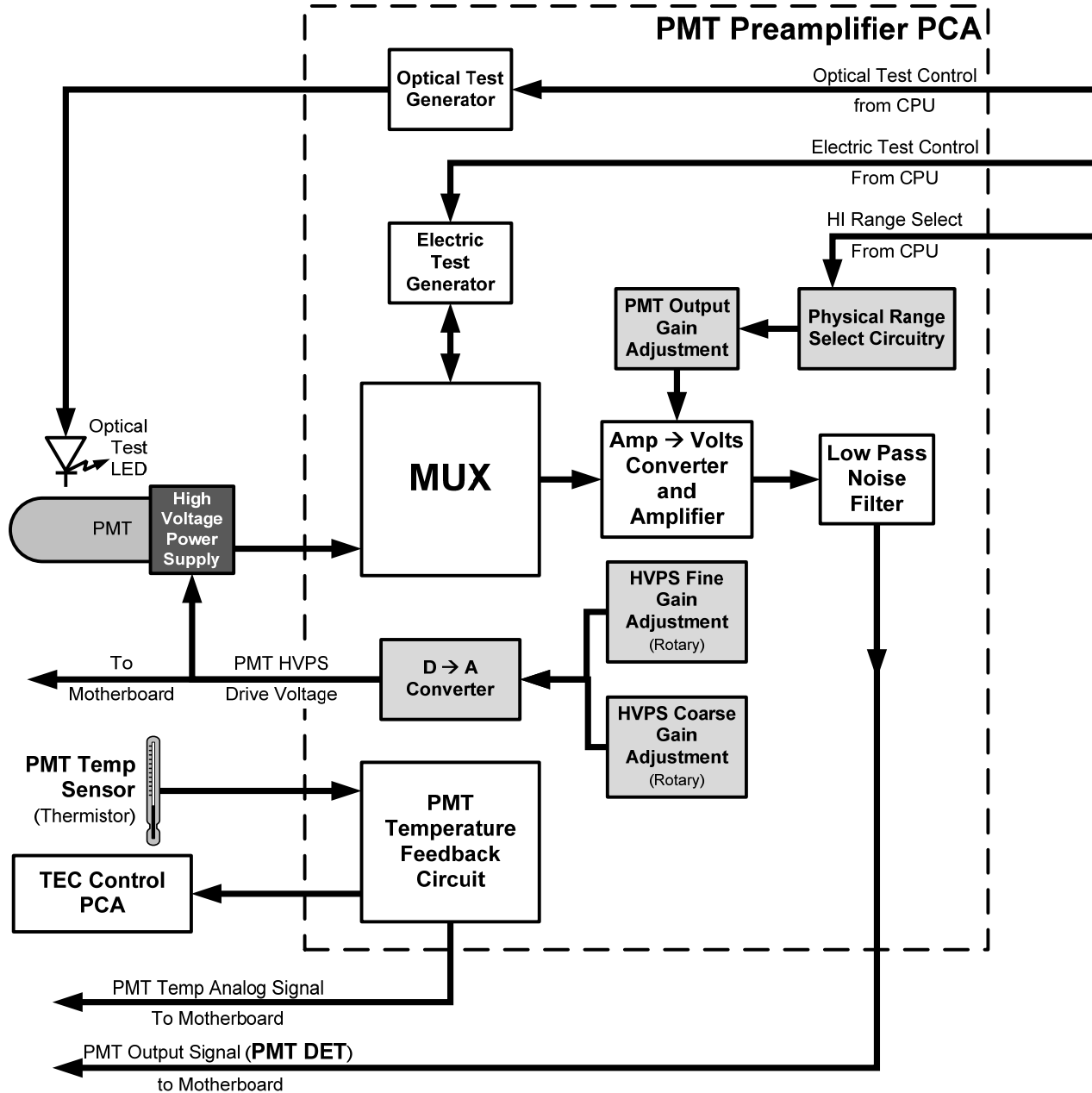

Figure 13-22: PMT Preamp Block Diagram

The PMT preamplifier PCA also operates two different tests used to calibrate and check the performance of the sensor module.

- The electrical test (**ETEST**) circuit generates a constant, electronic signal intended to simulate the output of the PMT (after conversion from current to voltage). By bypassing the detector's actual

signal, it is possible to test most of the signal handling and conditioning circuitry on the PMT preamplifier board. See section 12.7.12.2 for instructions on performing this test.

- The optical test (**OTEST**) feature causes an LED inside the PMT cold block to create a light signal that can be measured with the PMT. If zero air is supplied to the analyzer, the entire measurement capability of the sensor module can be tested including the PMT and the current to voltage conversion circuit on the PMT preamplifier board. See Section 12.7.12.1 for instructions on performing this test.

13.5.2. PMT COOLING SYSTEM

The performance of the analyzer's PMT is significantly affected by temperature. Variations in PMT temperature are directly reflected in the signal output of the PMT. Also the signal to noise ratio of the PMT output is radically influenced by temperature as well. The warmer the PMT is, the noisier its signal becomes until the noise renders the concentration signal useless.

To alleviate this problem a special cooling system exists utilizing a type of electronic heat pump called a thermo-electric cooler (TEC). A TEC is a solid-state active heat pump which transfers heat from a heat absorbing "cool" side to a heat releasing "hot" side via a series of DC powered semiconductor junctions. The effectiveness of the pump at moving heat away from the cold side is reliant on the amount of current flowing through the semiconductor junctions and how well the heat from the hot side can be removed.

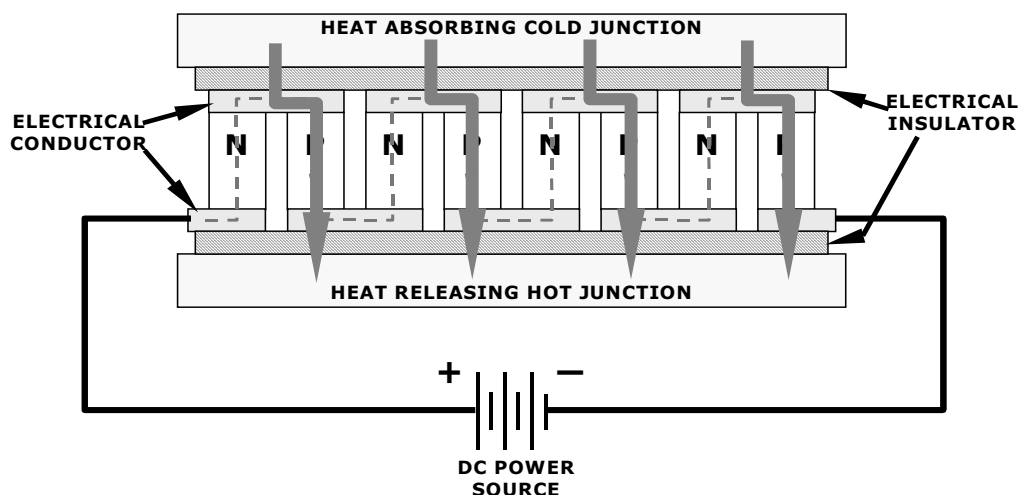

Figure 13-23: Typical Thermo-Electric Cooler

In the case of the 9110T, the current flow is controlled by the TEC Control PCA which adjusts the amount of current applied to the TEC based on the temperature sensed by a thermistor embedded in the PMT's cold block. The higher the temperature of the PMT, the more current is pumped through the TEC. The "hot" side of the TEC is cooled by a constant flow of ambient air that is directed across a set of heat sinks by a fan.

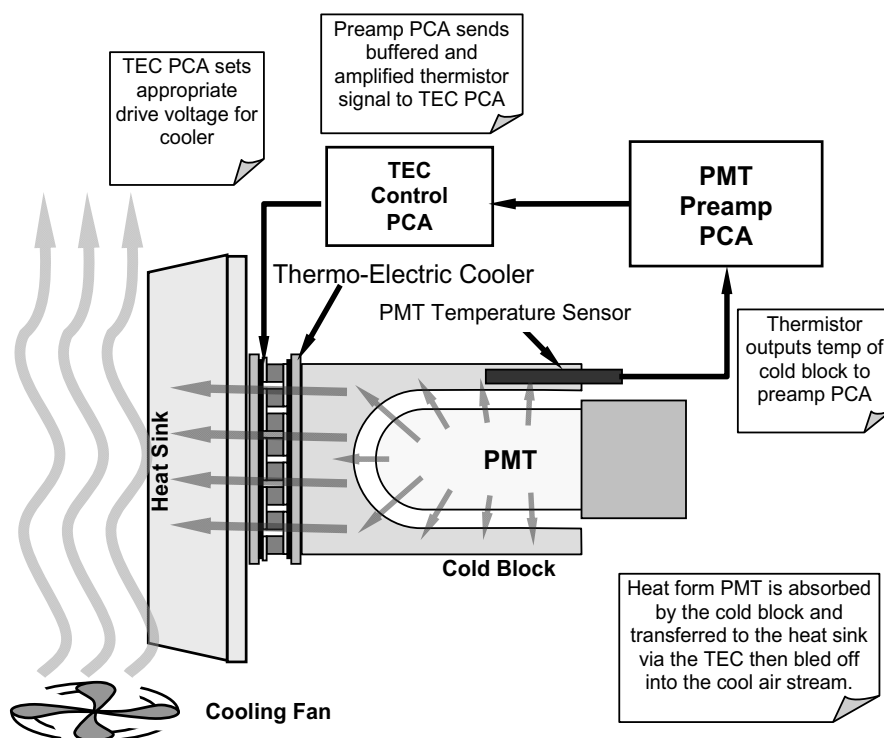

Figure 13-24: PMT Cooling System Block Diagram

The target temperature at which the TEC system keeps the PMT is approximately 8.0°C. Arriving at this temperature may take up to 30 minutes after the instrument is turned on.

The actual temperature of the PMT can be viewed via the front panel as the test function **PMT TEMP** (see Section 4.1.1).

13.5.2.1. TEC Control Board

The TEC control PCA is located on the sensor housing assembly, under the slanted shroud, next to the cooling fins and directly above the cooling fan. Using the amplified PMT temperature signal from the PMT preamplifier board (see Section 10.4.5), it sets the drive voltage for the thermoelectric cooler. The warmer the PMT gets, the more current is passed through the TEC causing it to pump more heat to the heat sink.

- A red LED located on the top edge of this circuit board indicates that the control circuit is receiving power.
- Four test points are also located at the top of this assembly.
- For the definitions and acceptable signal levels of these test points see 12.7.14.

13.6. PNEUMATIC SENSOR BOARD

The flow and pressure sensors of the 9110T are located on a printed circuit assembly just behind the PMT sensor. Refer to Section 12.7.6.1 for a figure and on how to test this assembly. The signals of this board are supplied to the motherboard for further signal processing. All sensors are linearized in the firmware and can be span calibrated from the front panel.

13.7. POWER SUPPLY/CIRCUIT BREAKER

The analyzer operates on 100 VAC, 115 VAC or 230 VAC power at either 50 Hz or 60Hz. Individual instruments are set up at the factory to accept any combination of these five attributes. A 6.75 amp circuit breaker is built into the **ON/OFF** switch. In case of a wiring fault or incorrect supply power, the circuit breaker will automatically turn off the analyzer.

- Under normal operation, the 9110T draws about 1.5 A at 115 V and 2.0 A during start-up.

	<p style="text-align: center;">WARNING ELECTRICAL SHOCK HAZARD</p> <p style="text-align: center;">Should the AC power circuit breaker trip, investigate and correct the condition causing this situation before turning the analyzer back on.</p>
---	--

Power enters the analyzer through a standard International Electrotechnical Commission (IEC) 320 power receptacle located on the rear panel of the instrument. From there it is routed through the **ON/OFF** Switch located in the lower right corner of the front panel. AC Line power is stepped down and converted to DC power by two DC power supplies (PS).

- One PS provides +5 VDC (3 A) and ± 15 VDC (1.5/0.5 A) for logic and analog circuitry as well as the power for the O₃ generator.
- A second PS provides +12 VDC (5 A), for the PMT's thermoelectric cooler, fans and as well as the various gas stream valves (both standard and optional).

All AC and DC Voltages are distributed via the relay PCA.

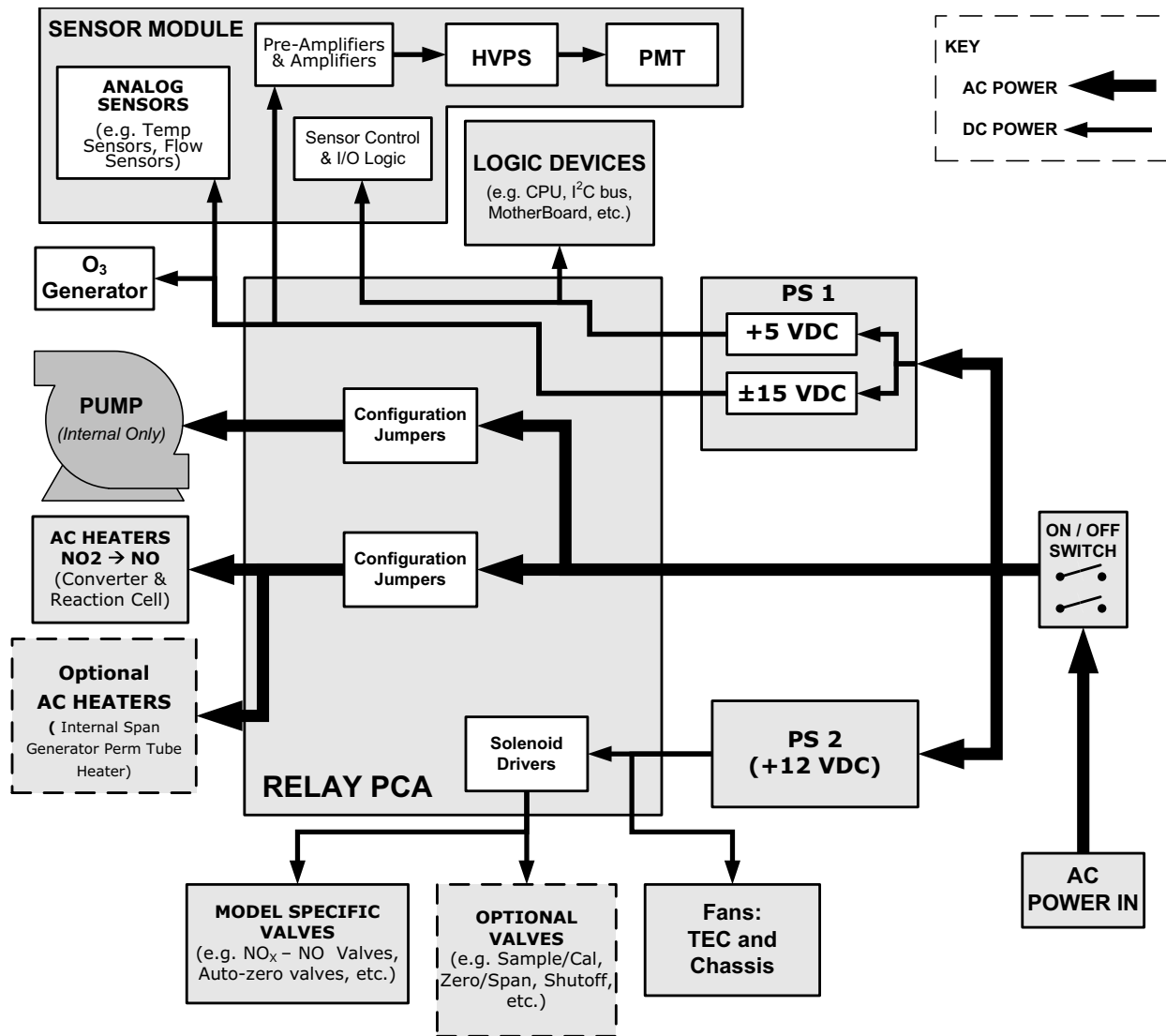

Figure 13-25: Power Distribution Block Diagram

13.7.1. AC POWER CONFIGURATION

The 9110T analyzer’s digital components will operate with any of the specified power regimes. As long as instrument is connected to 100-120 VAC or 220-240 VAC at either 50 or 60 Hz,. Internally, the status LEDs located on the Relay PCA, Motherboard and CPU should turn on as soon as the power is supplied.

However, some of the analyzer’s non-digital components, such as the various internal pump options or the AC powered heaters for the NO₂ → NO converter the reaction cell and some of the 9110T’s must be properly configured for the type of power being supplied to the instrument.

Configuration of the power circuits is set using several jumper sets located on the instruments relay PCA.

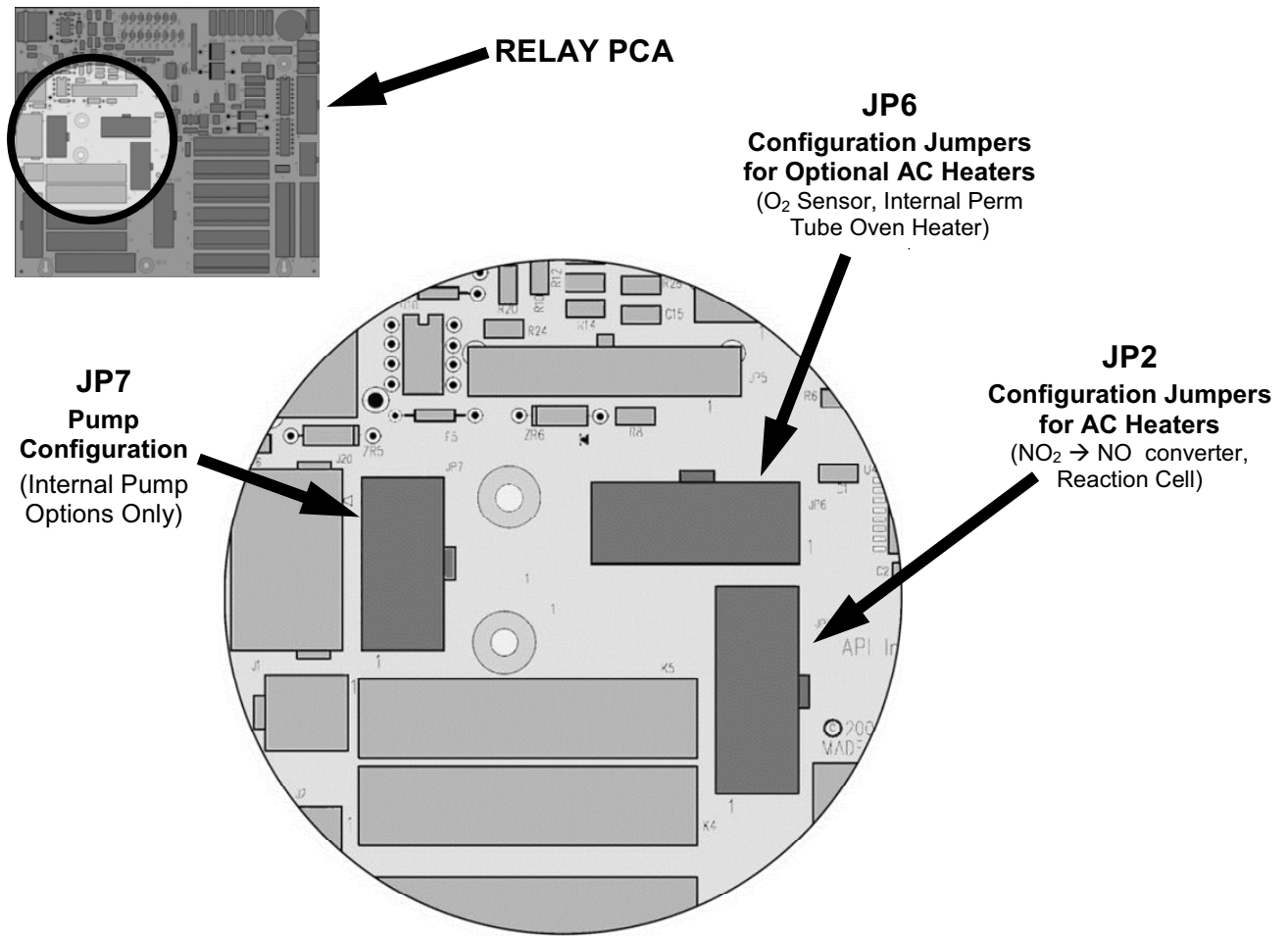

Figure 13-26: Location of AC power Configuration Jumpers

13.7.1.1. AC Configuration – Internal Pump (JP7)

If your 9110T includes an internal pump the following table, jumper set JP7 is used to configure the power supplied to it as shown in Figure 13-27.

Table 13-6: AC Power Configuration for Internal Pumps (JP7)

LINE POWER	LINE FREQUENCY	JUMPER COLOR	FUNCTION	JUMPER BETWEEN PINS
110VAC 115 VAC	60 HZ	WHITE	Connects pump pin 3 to 110 / 115 VAC power line	2 to 7
			Connects pump pin 3 to 110 / 115 VAC power line	3 to 8
			Connects pump pins 2 & 4 to Neutral	4 to 9
	50 HZ ¹	BLACK	Connects pump pin 3 to 110 / 115 VAC power line	2 to 7
			Connects pump pin 3 to 110 / 115 VAC power line	3 to 8
			Connects pump pins 2 & 4 to Neutral	4 to 9
220VAC 240 VAC	60 HZ	BROWN	Connects pump pins 3 and 4 together	1 to 6
			Connects pump pin 1 to 220 / 240VAC power line	3 to 8
	50 HZ ¹	BLUE	Connects pump pins 3 and 4 together	1 to 6
			Connects pump pin 1 to 220 / 240VAC power line	3 to 8

¹ A jumper between pins 5 and 10 may be present on the jumper plug assembly, but has no function on the Model 9110T.

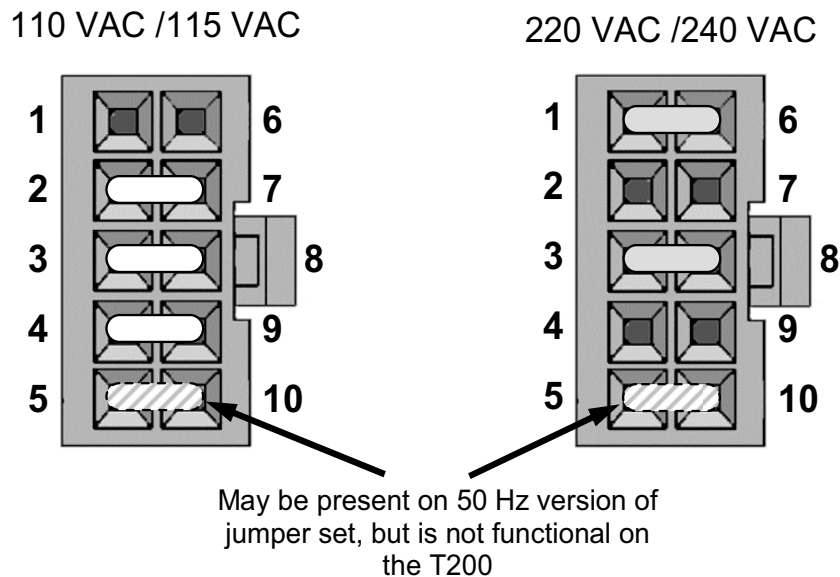

Figure 13-27: Pump AC Power Jumpers (JP7)

13.7.1.2. AC Configuration – Standard Heaters (JP2)

Power configuration for the AC the standard heaters is set using Jumper set JP2 (see Figure 13-28 for the location of JP2).

Table 13-7: Power Configuration for Standard AC Heaters (JP2)

LINE VOLTAGE	JUMPER COLOR	HEATER(S)	JUMPER BETWEEN PINS	FUNCTION
110 VAC / 115 VAC 50Hz & 60 Hz	WHITE	Reaction Cell / Sample Chamber Heaters	1 to 8	Common
			2 to 7	Neutral to Load
			4 to 9	Neutral to Load
		Moly Converter	3 to 10	Common
			4 to 9	Neutral to Load
			6 to 11	Neutral to Load
220 VAC / 240 VAC 50Hz & 60 Hz	BLUE	Reaction Cell / Sample Chamber Heaters	1 to 7	Load
		Moly Converter	3 to 9	Load

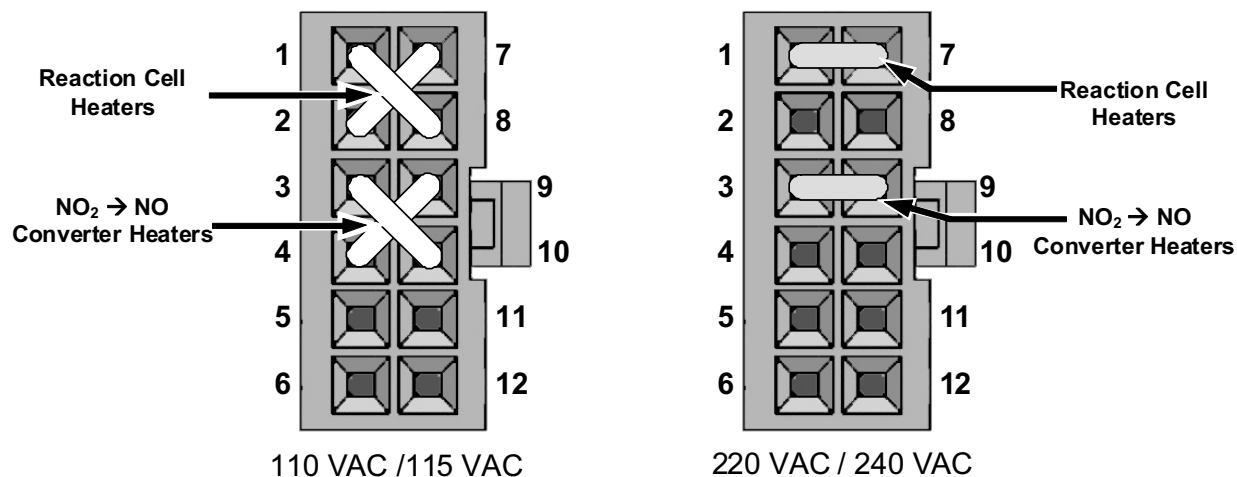

Figure 13-28: Typical Set Up of AC Heater Jumper Set (JP2)

13.7.1.3. AC Configuration – Heaters for Option Packages (JP6)

The IZS valve option includes an AC heaters that maintain an optimum operating temperature for key components of those options. Jumper set JP6 is used to connect the heaters associated with those options to AC power. Since these heaters work with either 110/155 VAC or 220/240 VAC, there is only one jumper configuration.

Table 13-8: Power Configuration for Optional Heaters (JP6)

JUMPER COLOR	HEATER(S)	JUMPER BETWEEN PINS	FUNCTION
RED	Internal Permeation Tube Oven Heater	1 to 8	Common
		2 to 7	Neutral to Load

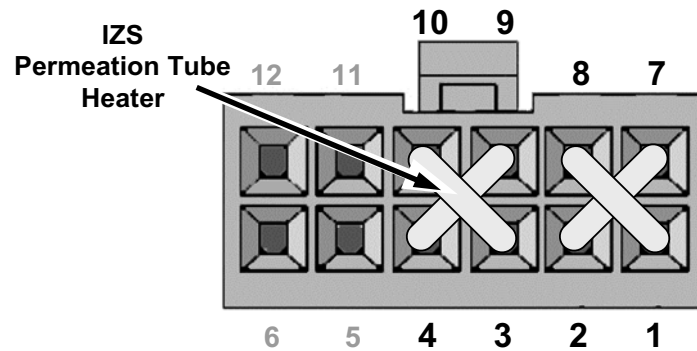

Figure 13-29: Typical Jumper Set (JP2) Set Up of Heaters

13.8. FRONT PANEL TOUCHSCREEN/DISPLAY INTERFACE

Users can input data and receive information directly through the front panel touchscreen display. The LCD display is controlled directly by the CPU board. The touchscreen is interfaced to the CPU by means of a touchscreen controller that connects to the CPU via the internal USB bus and emulates a computer mouse.

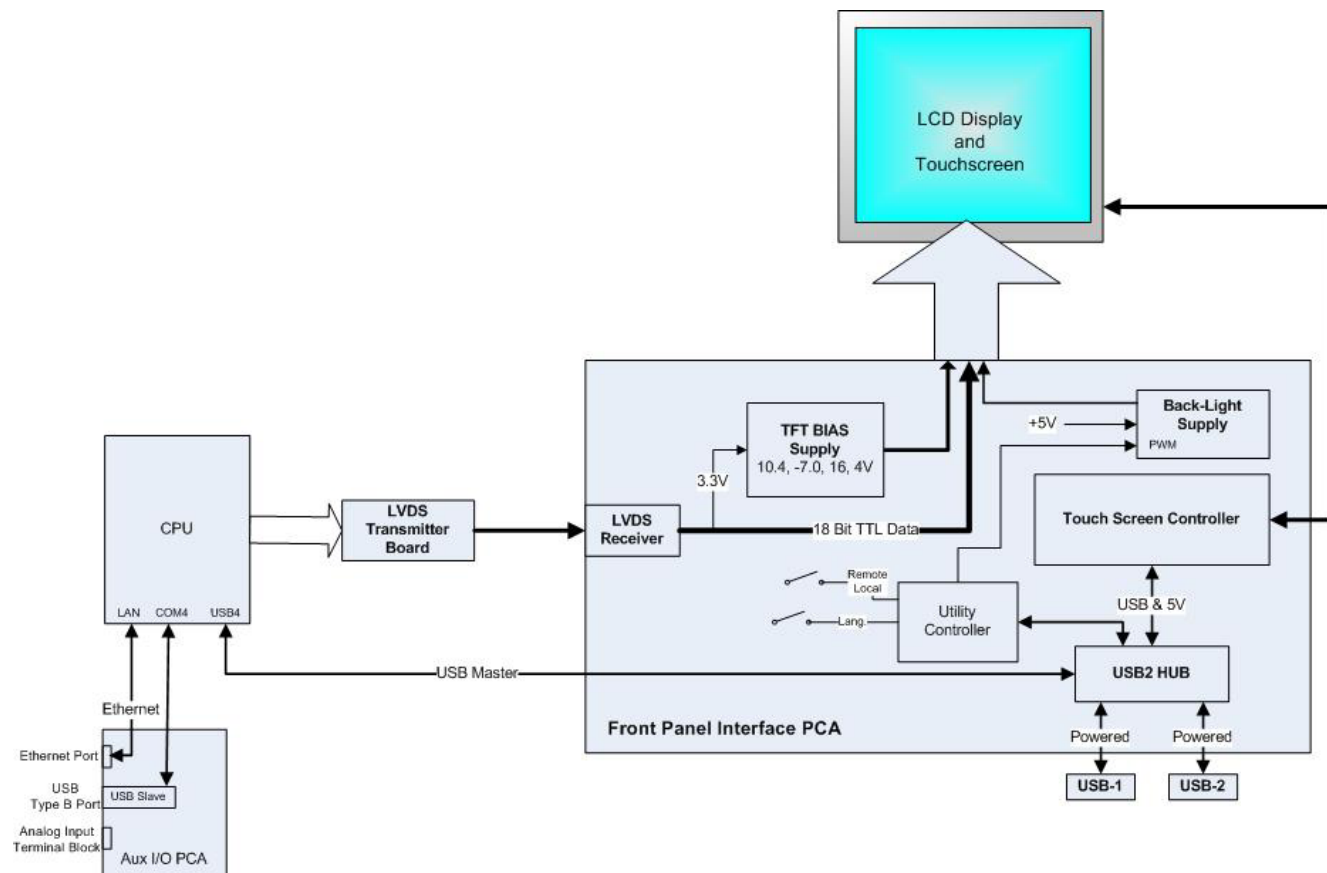

Figure 13-30: Front Panel and Display Interface Block Diagram

13.8.1. LVDS TRANSMITTER BOARD

The LVDS (low voltage differential signaling) transmitter board converts the parallel display bus to a serialized, low voltage, differential signal bus in order to transmit the video signal to the LCD interface PCA.

13.8.2. FRONT PANEL TOUCHSCREEN/DISPLAY INTERFACE PCA

The front panel interface PCA controls the various functions of the display and touchscreen. For driving the display it provides connection between the CPU video controller and the LCD display module. This PCA also contains:

- Power supply circuitry for the LCD display module
- A USB hub that is used for communications with the touchscreen controller and the two front panel USB device ports
- The circuitry for powering the display backlight

13.9. SOFTWARE OPERATION

The 9110T NO_x Analyzer has a high performance, VortexX86-based microcomputer running WINDOWS CE. Inside the WINDOWS CE shell, special software developed by Teledyne interprets user commands via the various interfaces, performs procedures and tasks, stores data in the CPU's various memory devices and calculates the concentration of the sample gas.

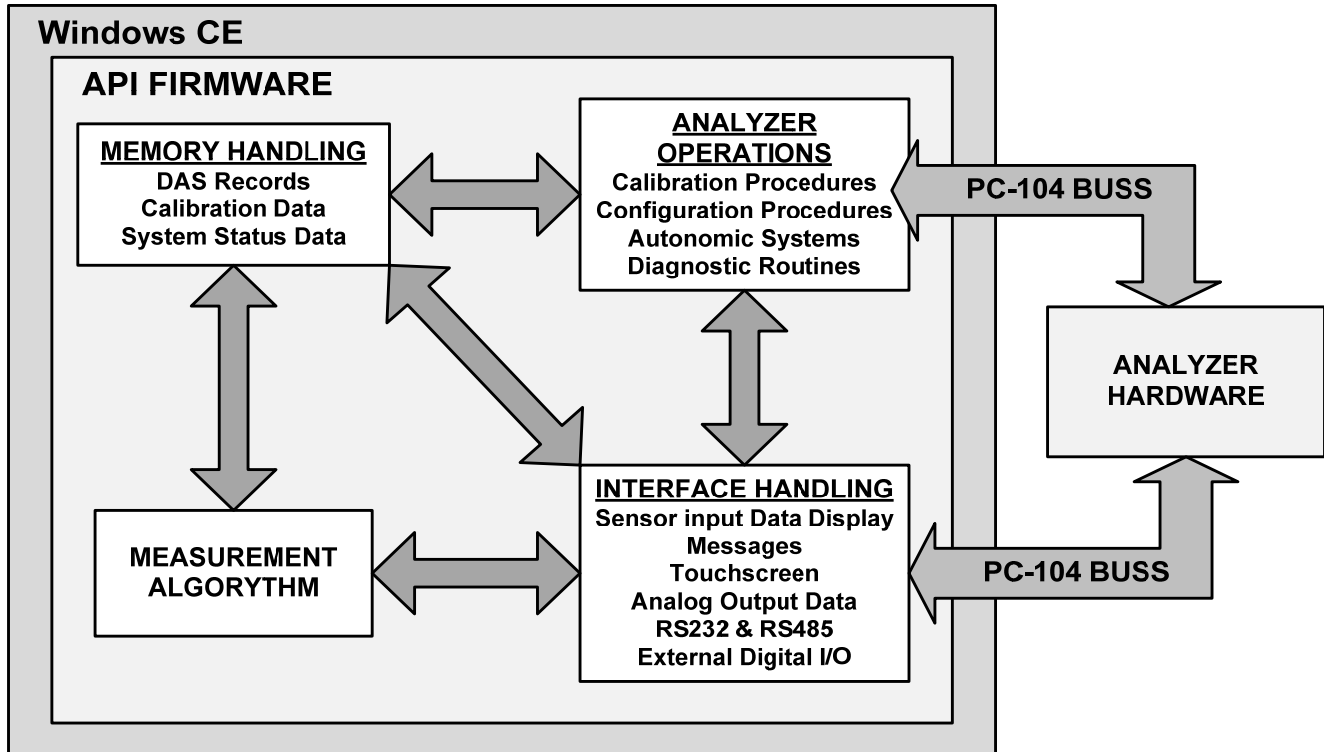

Figure 13-31: Basic Software Operation

13.9.1. ADAPTIVE FILTER

The 9110T NO_x analyzer software processes sample gas concentration data through a built-in adaptive filter. Unlike other analyzers that average the output signal over a fixed time period, the 9110T averages over a defined number of samples, with samples being about 8 seconds apart (reflecting the switching time of 4 s each for NO and NO_x). This technique is known as boxcar filtering. During operation, the software may automatically switch between two different filters lengths based on the conditions at hand.

During constant or nearly constant concentrations, the software, by default, computes an average of the last 42 samples, or approximately 5.6 minutes. This provides smooth and stable readings and averages out a considerable amount of random noise for an overall less noisy concentration reading.

If the filter detects rapid changes in concentration the filter reduces the averaging to only 6 samples or about 48 seconds to allow the analyzer to respond more quickly. Two conditions must be simultaneously met to switch to the short filter. First, the instantaneous concentration must differ from the average in the long filter by at least 50 ppb. Second, the instantaneous concentration must differ from the average in the long filter by at least 10% of the average in the long filter

13.9.2. TEMPERATURE/PRESSURE COMPENSATION (TPC)

The 9110T software includes a feature that compensates for some temperature and pressure changes that might affect measurement of NO and NO_x concentrations.

When the TPC feature is enabled (default setting), the analyzer divides the value of the PMT output signal (**PMTDET**) by a value called **TP_FACTOR**, which is calculated using the following four parameters:

- **BOX TEMP**: The temperature inside the analyzer's case measured in K. This is typically about 5 K higher than room temperature.
- **RCELL TEMP**: The temperature of the reaction cell, measured in K.
- **RCEL**: The pressure of the gas in the vacuum manifold, measured in in-Hg-A.
- **SAMP**: The pressure of the sample gas before it reaches the reaction cell, measured in in-Hg-A. This measurement is ~1 in-Hg-A lower than atmospheric pressure.

As **RCEL TEMP**, **BOX TEMP**, **RCELL** and **SAMP** pressure increase, the value of **TP_FACTOR** increases and, hence, the **PMTDET** value decreases. These adjustments are meant to counter-act changes in the concentrations caused by these parameters.

- The current value of all four of these measurements are viewable as **TEST FUNCTIONS** through the instrument's front panel display (see Section 4.1.1).
- The preset gain parameters are set at the factory and may vary from analyzer to analyzer. The TPC feature is enabled or disabled by setting the value of the variable **TPC_ENABLE** (see Section 5.8).

13.9.3. CALIBRATION - SLOPE AND OFFSET

Calibration of the analyzer is performed exclusively in software. During instrument calibration, (see Sections 9 and 10) the user enters expected values for zero and span via the front panel touchscreen control and commands the instrument to make readings of calibrated sample gases for both levels.

- The readings taken are adjusted, linearized and compared to the expected values.
- With this information, the software computes values for instrument slope and offset and stores these values in memory for use in calculating the NO_x, NO and NO₂ concentrations of the sample gas.

The instrument slope and offset values recorded during the last calibration can be viewed via the instrument's front panel (see Section 4.1.1).

14. A PRIMER ON ELECTRO-STATIC DISCHARGE

TAI considers the prevention of damage caused by the discharge of static electricity to be extremely important part of making sure that your analyzer continues to provide reliable service for a long time. This section describes how static electricity occurs, why it is so dangerous to electronic components and assemblies as well as how to prevent that damage from occurring.

14.1. HOW STATIC CHARGES ARE CREATED

Modern electronic devices such as the types used in the various electronic assemblies of your analyzer, are very small, require very little power and operate very quickly. Unfortunately, the same characteristics that allow them to do these things also make them very susceptible to damage from the discharge of static electricity. Controlling electrostatic discharge begins with understanding how electrostatic charges occur in the first place.

Static electricity is the result of something called triboelectric charging which happens whenever the atoms of the surface layers of two materials rub against each other. As the atoms of the two surfaces move together and separate, some electrons from one surface are retained by the other.

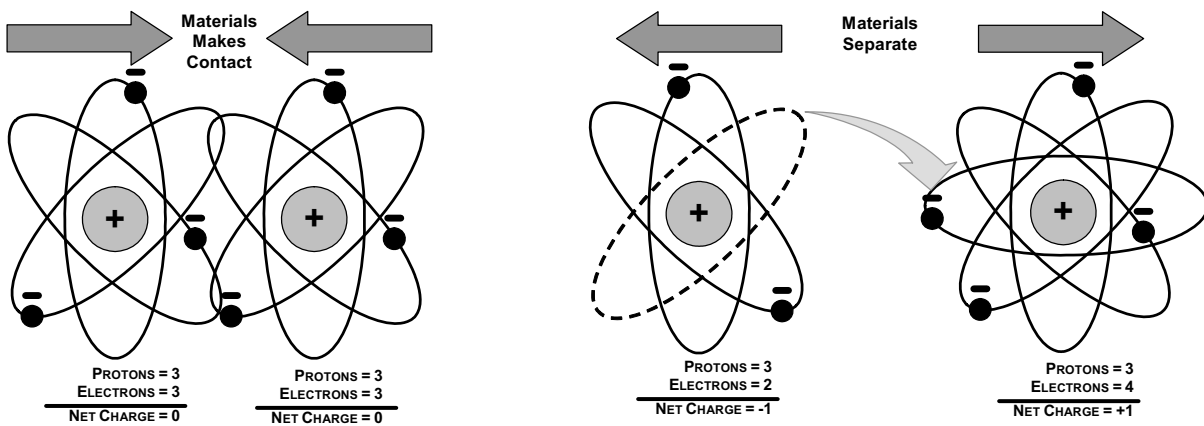

Figure 14-1: Triboelectric Charging

If one of the surfaces is a poor conductor or even a good conductor that is not grounded, the resulting positive or negative charge cannot bleed off and becomes trapped in place, or static. The most common example of triboelectric charging happens when someone wearing leather or rubber soled shoes walks across a nylon carpet or linoleum tiled floor. With each step, electrons change places and the resulting electro-static charge builds up, quickly reaching significant levels. Pushing an epoxy printed circuit board across a workbench, using a plastic handled screwdriver or even the constant jostling of Styrofoam™ pellets during shipment can also build hefty static charges.

Table 14-1: Static Generation Voltages for Typical Activities

MEANS OF GENERATION	65-90% RH	10-25% RH
Walking across nylon carpet	1,500V	35,000V
Walking across vinyl tile	250V	12,000V
Worker at bench	100V	6,000V
Poly bag picked up from bench	1,200V	20,000V
Moving around in a chair padded with urethane foam	1,500V	18,000V

14.2. HOW ELECTRO-STATIC CHARGES CAUSE DAMAGE

Damage to components occurs when these static charges come into contact with an electronic device. Current flows as the charge moves along the conductive circuitry of the device and the typically very high voltage levels of the charge overheat the delicate traces of the integrated circuits, melting them or even vaporizing parts of them. When examined by microscope the damage caused by electro-static discharge looks a lot like tiny bomb craters littered across the landscape of the component's circuitry.

A quick comparison of the values in with the those shown in the , listing device susceptibility levels, shows why *Semiconductor Reliability News* estimates that approximately 60% of device failures are the result of damage due to electro-static discharge.

Table 14-2: Sensitivity of Electronic Devices to Damage by ESD

DEVICE	DAMAGE SUSCEPTIBILITY VOLTAGE RANGE	
	DAMAGE BEGINS OCCURRING AT	CATASTROPHIC DAMAGE AT
MOSFET	10	100
VMOS	30	1800
NMOS	60	100
GaAsFET	60	2000
EPROM	100	100
JFET	140	7000
SAW	150	500
Op-AMP	190	2500
CMOS	200	3000
Schottky Diodes	300	2500
Film Resistors	300	3000
This Film Resistors	300	7000
ECL	500	500
SCR	500	1000
Schottky TTL	500	2500

Potentially damaging electro-static discharges can occur:

- Any time a charged surface (including the human body) discharges to a device. Even simple contact of a finger to the leads of a sensitive device or assembly can allow enough discharge to cause damage. A similar discharge can occur from a charged conductive object, such as a metallic tool or fixture.
- When static charges accumulated on a sensitive device discharges from the device to another surface such as packaging materials, work surfaces, machine surfaces or other device. In some cases, charged device discharges can be the most destructive.
- A typical example of this is the simple act of installing an electronic assembly into the connector or wiring harness of the equipment in which it is to function. If the assembly is carrying a static charge, as it is connected to ground a discharge will occur.
- Whenever a sensitive device is moved into the field of an existing electro-static field, a charge may be induced on the device in effect discharging the field onto the device. If the device is then momentarily grounded while within the electrostatic field or removed from the region of the electrostatic field and grounded somewhere else, a second discharge will occur as the charge is transferred from the device to ground.

14.3. COMMON MYTHS ABOUT ESD DAMAGE

- **I didn't feel a shock so there was no electro-static discharge:** The human nervous system isn't able to feel a static discharge of less than 3500 volts. Most devices are damaged by discharge levels much lower than that.
- **I didn't touch it so there was no electro-static discharge:** Electro Static charges are fields whose lines of force can extend several inches or sometimes even feet away from the surface bearing the charge.
- **It still works so there was no damage:** Sometimes the damages caused by electro-static discharge can completely sever a circuit trace causing the device to fail immediately. More likely, the trace will be only partially occluded by the damage causing degraded performance of the device or worse, weakening the trace. This weakened circuit may seem to function fine for a short time, but even the very low voltage and current levels of the device's normal operating levels will eat away at the defect over time causing the device to fail well before its designed lifetime is reached.
- These latent failures are often the most costly since the failure of the equipment in which the damaged device is installed causes down time, lost data, lost productivity, as well as possible failure and damage to other pieces of equipment or property.
- Static Charges can't build up on a conductive surface: There are two errors in this statement.
- Conductive devices can build static charges if they are not grounded. The charge will be equalized across the entire device, but without access to earth ground, they are still trapped and can still build to high enough levels to cause damage when they are discharged.
- A charge can be induced onto the conductive surface and/or discharge triggered in the presence of a charged field such as a large static charge clinging to the surface of a nylon jacket of someone walking up to a workbench.
- **As long as my analyzer is properly installed, it is safe from damage caused by static discharges:** It is true that when properly installed the chassis ground of your analyzer is tied to earth ground and its electronic components are prevented from building static electric charges themselves. This does not prevent discharges from static fields built up on other things, like you and your clothing, from discharging through the instrument and damaging it.

14.4. BASIC PRINCIPLES OF STATIC CONTROL

It is impossible to stop the creation of instantaneous static electric charges. It is not, however difficult to prevent those charges from building to dangerous levels or prevent damage due to electro-static discharge from occurring.

14.4.1. GENERAL RULES

Only handle or work on all electronic assemblies at a properly set up ESD station. Setting up an ESD safe workstation need not be complicated. A protective mat properly tied to ground and a wrist strap are all that is needed to create a basic anti-ESD workstation.

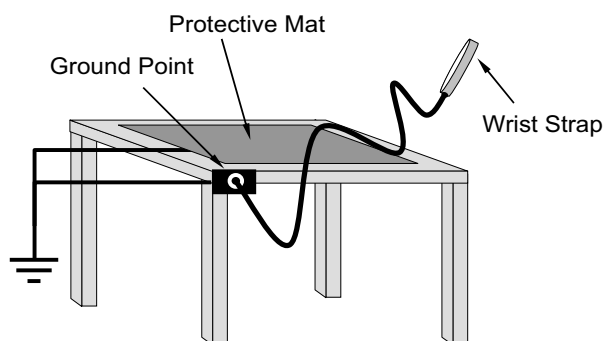

Figure 14-2: Basic anti-ESD Workbench

For technicians that work in the field, special lightweight and portable anti-ESD kits are available from most suppliers of ESD protection gear. These include everything needed to create a temporary anti-ESD work area anywhere.

- **Always wear an Anti-ESD wrist strap when working on the electronic assemblies of your analyzer.** An anti-ESD wrist strap keeps the person wearing it at or near the same potential as other grounded objects in the work area and allows static charges to dissipate before they can build to dangerous levels. Anti-ESD wrist straps terminated with alligator clips are available for use in work areas where there is no available grounded plug.
- Also, anti-ESD wrist straps include a current limiting resistor (usually around one meg-ohm) that protects you should you accidentally short yourself to the instrument's power supply.
- **Simply touching a grounded piece of metal is insufficient.** While this may temporarily bleed off static charges present at the time, once you stop touching the grounded metal new static charges will immediately begin to re-build. In some conditions, a charge large enough to damage a component can rebuild in just a few seconds.
- **Always store sensitive components and assemblies in anti-ESD storage bags or bins:** Even when you are not working on them, store all devices and assemblies in a closed anti-Static bag or bin. This will prevent induced charges from building up on the device or assembly and nearby static fields from discharging through it.
- **Use metallic anti-ESD bags for storing and shipping ESD sensitive components and assemblies rather than pink-poly bags.** The famous, pink-poly bags are made of a plastic that is impregnated with a liquid (similar to liquid laundry detergent) which very slowly sweats onto the surface of the plastic creating a slightly conductive layer over the surface of the bag.
- While this layer may equalizes any charges that occur across the whole bag, it does not prevent the build up of static charges. If laying on a conductive, grounded surface, these bags will allow charges to bleed away but the very charges that build up on the surface of the bag itself can be transferred through the bag by induction onto the circuits of your ESD sensitive device. Also, the liquid impregnating the plastic is eventually used up after which the bag is as useless for preventing damage from ESD as any ordinary plastic bag.
- Anti-Static bags made of plastic impregnated with metal (usually silvery in color) provide all of the charge equalizing abilities of the pink-poly bags but also, when properly sealed, create a Faraday cage that completely isolates the contents from discharges and the inductive transfer of static charges.
- Storage bins made of plastic impregnated with carbon (usually black in color) are also excellent at dissipating static charges and isolating their contents from field effects and discharges.

- **Never use ordinary plastic adhesive tape near an ESD sensitive device or to close an anti-ESD bag.** The act of pulling a piece of standard plastic adhesive tape, such as Scotch[®] tape, from its roll will generate a static charge of several thousand or even tens of thousands of volts on the tape itself and an associated field effect that can discharge through or be induced upon items up to a foot away.

14.5. BASIC ANTI-ESD PROCEDURES FOR ANALYZER REPAIR AND MAINTENANCE

14.5.1. WORKING AT THE INSTRUMENT RACK

When working on the analyzer while it is in the instrument rack and plugged into a properly grounded power supply:

1. Attach your anti-ESD wrist strap to ground before doing anything else.
 - Use a wrist strap terminated with an alligator clip and attach it to a bare metal portion of the instrument chassis.
 - This will safely connect you to the same ground level to which the instrument and all of its components are connected.
2. Pause for a second or two to allow any static charges to bleed away.
3. Open the casing of the analyzer and begin work. Up to this point, the closed metal casing of your analyzer has isolated the components and assemblies inside from any conducted or induced static charges.
4. If you must remove a component from the instrument, do not lay it down on a non-ESD preventative surface where static charges may lie in wait.
5. Only disconnect your wrist strap after you have finished work and closed the case of the analyzer.

14.5.2. WORKING AT AN ANTI-ESD WORK BENCH

When working on an instrument of an electronic assembly while it is resting on a anti-ESD workbench:

1. Plug your anti-ESD wrist strap into the grounded receptacle of the work station before touching any items on the work station and while standing at least a foot or so away. This will allow any charges you are carrying to bleed away through the ground connection of the workstation and prevent discharges due to field effects and induction from occurring.
2. Pause for a second or two to allow any static charges to bleed away.
3. Only open any anti-ESD storage bins or bags containing sensitive devices or assemblies after you have plugged your wrist strap into the workstation.
 - Lay the bag or bin on the workbench surface.
 - Before opening the container, wait several seconds for any static charges on the outside surface of the container to be bled away by the workstation's grounded protective mat.
4. Do not pick up tools that may be carrying static charges while also touching or holding an ESD sensitive device.

- Only lay tools or ESD-sensitive devices and assemblies on the conductive surface of your workstation. Never lay them down on any non-ESD preventative surface.
5. Place any static sensitive devices or assemblies in anti-static storage bags or bins and close the bag or bin before unplugging your wrist strap.
 6. Disconnecting your wrist strap is always the last action taken before leaving the workbench.

14.5.3. TRANSFERRING COMPONENTS BETWEEN RACK AND BENCH

When transferring a sensitive device from an installed TAI analyzer to an Anti-ESD workbench or rack:

1. Follow the instructions listed above for working at the instrument rack and workstation.
2. Never carry the component or assembly without placing it in an anti-ESD bag or bin.
3. Before using the bag or container allow any surface charges on it to dissipate:
 - If you are at the instrument rack, hold the bag in one hand while your wrist strap is connected to a ground point.
 - If you are at an anti-ESD workbench, lay the container down on the conductive work surface.
 - In either case wait several seconds.
4. Place the item in the container.
5. Seal the container. If using a bag, fold the end over and fastening it with anti-ESD tape.
 - Folding the open end over isolates the component(s) inside from the effects of static fields.
 - Leaving the bag open or simply stapling it shut without folding it closed prevents the bag from forming a complete protective envelope around the device.
6. Once you have arrived at your destination, allow any surface charges that may have built up on the bag or bin during travel to dissipate:
 - Connect your wrist strap to ground.
 - If you are at the instrument rack, hold the bag in one hand while your wrist strap is connected to a ground point.
 - If you are at a anti-ESD workbench, lay the container down on the conductive work surface.
 - In either case wait several seconds.
7. Open the container.

14.5.4. OPENING SHIPMENTS FROM TAI CUSTOMER SERVICE

Packing materials such as bubble pack and Styrofoam pellets are extremely efficient generators of static electric charges. To prevent damage from ESD, TAI ships all electronic components and assemblies in properly sealed ant-ESD containers.

Static charges will build up on the outer surface of the anti-ESD container during shipping as the packing materials vibrate and rub against each other. To prevent these static charges from damaging the components or assemblies being shipped ensure that you:

Always unpack shipments from Teledyne Customer Service by:

1. Opening the outer shipping box away from the anti-ESD work area.
2. Carry the still sealed anti-ESD bag, tube or bin to the anti-ESD work area.
3. Follow steps 6 and 7 of Section 14.2.3 above when opening the anti-ESD container at the work station.
4. Reserve the anti-ESD container or bag to use when packing electronic components or assemblies to be returned to TAI.

14.5.5. PACKING COMPONENTS FOR RETURN TO TAI CUSTOMER SERVICE

Always pack electronic components and assemblies to be sent to Teledyne Customer Service in anti-ESD bins, tubes or bags.

CAUTION
ESD Hazard



- **DO NOT use pink-poly bags.**
- **NEVER allow any standard plastic packaging materials to touch the electronic component/assembly directly.**
 - **This includes, but is not limited to, plastic bubble-pack, Styrofoam peanuts, open cell foam, closed cell foam, and adhesive tape.**
- **DO NOT use standard adhesive tape as a sealer. Use ONLY anti-ESD tape.**

Never carry the component or assembly without placing it in an anti-ESD bag or bin.

1. Before using the bag or container allow any surface charges on it to dissipate:
 - If you are at the instrument rack, hold the bag in one hand while your wrist strap is connected to a ground point.
 - If you are at an anti-ESD workbench, lay the container down on the conductive work surface.
 - In either case wait several seconds.
2. Place the item in the container.
3. Seal the container. If using a bag, fold the end over and fastening it with anti-ESD tape.
 - Folding the open end over isolates the component(s) inside from the effects of static fields.

- Leaving the bag open or simply stapling it shut without folding it closed prevents the bag from forming a complete protective envelope around the device.

Note

If you do not already have an adequate supply of anti-ESD bags or containers available, Teledyne Customer Service department will supply them (see Section 12.10 for contact information). Follow the instructions listed above for working at the instrument rack and workstation.

GLOSSARY

Term	Description/Definition
10BaseT	an Ethernet standard that uses twisted ("T") pairs of copper wires to transmit at 10 megabits per second (Mbps)
100BaseT	same as 10BaseT except ten times faster (100 Mbps)
APICOM	name of a remote control program offered by Teledyne-API to its customers
ASSY	<i>Assembly</i>
CAS	<i>Code-Activated Switch</i>
CD	<i>Corona Discharge</i> , a frequently luminous discharge, at the surface of a conductor or between two conductors of the same transmission line, accompanied by ionization of the surrounding atmosphere and often by a power loss
CE	<i>Converter Efficiency</i> , the percentage of the total amount that is actually converted (e.g., light energy into electricity; NO ₂ into NO, etc.)
CEM	<i>Continuous Emission Monitoring</i>
Chemical formulas that may be included in this document:	
CO ₂	carbon dioxide
C ₃ H ₈	propane
CH ₄	methane
H ₂ O	water vapor
HC	general abbreviation for hydrocarbon
HNO ₃	nitric acid
H ₂ S	hydrogen sulfide
NO	nitric oxide
NO ₂	nitrogen dioxide
NO _x	nitrogen oxides, here defined as the sum of NO and NO ₂
NO _y	nitrogen oxides, often called odd nitrogen: the sum of NO _x plus other compounds such as HNO ₃ (definitions vary widely and may include nitrate (NO ₃), PAN, N ₂ O and other compounds as well)
NH ₃	ammonia
O ₂	molecular oxygen
O ₃	ozone

Term	Description/Definition
SO ₂	sulfur dioxide
cm ³	metric abbreviation for <i>cubic centimeter</i> (replaces the obsolete abbreviation "cc")
CPU	<i>Central Processing Unit</i>
DAC	<i>Digital-to-Analog Converter</i>
DAS	<i>Data Acquisition System</i>
DCE	<i>Data Communication Equipment</i>
DFU	<i>Dry Filter Unit</i>
DHCP	<i>Dynamic Host Configuration Protocol</i> . A protocol used by LAN or Internet servers to automatically set up the interface protocols between themselves and any other addressable device connected to the network
DIAG	<i>Diagnostics</i> , the diagnostic settings of the analyzer.
DOM	<i>Disk On Module</i> , a 44-pin IDE flash drive with up to 128MB storage capacity for instrument's firmware, configuration settings and data
DOS	<i>Disk Operating System</i>
DRAM	<i>Dynamic Random Access Memory</i>
DR-DOS	<i>Digital Research DOS</i>
DTE	<i>Data Terminal Equipment</i>
EEPROM	<i>Electrically Erasable Programmable Read-Only Memory</i> also referred to as a FLASH chip or drive
ESD	<i>Electro-Static Discharge</i>
E TEST	<i>Electrical Test</i>
Ethernet	a standardized (IEEE 802.3) computer networking technology for local area networks (LANs), facilitating communication and sharing resources
FEP	<i>Fluorinated Ethylene Propylene</i> polymer, one of the polymers that Du Pont markets as <i>Teflon</i> [®]
Flash	non-volatile, solid-state memory
FPI	<i>Fabry-Perot Interface</i> : a special light filter typically made of a transparent plate with two reflecting surfaces or two parallel, highly reflective mirrors
GFC	<i>Gas Filter Correlation</i>
I ² C bus	a clocked, bi-directional, serial bus for communication between individual analyzer components

Term	Description/Definition
IC	<i>Integrated Circuit</i> , a modern, semi-conductor circuit that can contain many basic components such as resistors, transistors, capacitors etc in a miniaturized package used in electronic assemblies
IP	<i>Internet Protocol</i>
IZS	<i>Internal Zero Span</i>
LAN	<i>Local Area Network</i>
LCD	<i>Liquid Crystal Display</i>
LED	<i>Light Emitting Diode</i>
LPM	<i>Liters Per Minute</i>
MFC	<i>Mass Flow Controller</i>
M/R	<i>Measure/Reference</i>
NDIR	<i>Non-Dispersive Infrared</i>
MOLAR MASS	<p>the mass, expressed in grams, of 1 mole of a specific substance. Conversely, one mole is the amount of the substance needed for the molar mass to be the same number in grams as the atomic mass of that substance.</p> <p>EXAMPLE: The atomic weight of Carbon is 12 therefore the molar mass of Carbon is 12 grams. Conversely, one mole of carbon equals the amount of carbon atoms that weighs 12 grams.</p> <p>Atomic weights can be found on any Periodic Table of Elements.</p>
NDIR	<i>Non-Dispersive Infrared</i>
NIST-SRM	<i>National Institute of Standards and Technology - Standard Reference Material</i>
PC	<i>Personal Computer</i>
PCA	<i>Printed Circuit Assembly</i> , the PCB with electronic components, ready to use
PC/AT	<i>Personal Computer / Advanced Technology</i>
PCB	<i>Printed Circuit Board</i> , the bare board without electronic component
PFA	<i>Per-Fluoro-Alkoxy</i> , an inert polymer; one of the polymers that <i>Du Pont</i> markets as <i>Teflon</i> [®]
PLC	<i>Programmable Logic Controller</i> , a device that is used to control instruments based on a logic level signal coming from the analyzer
PLD	<i>Programmable Logic Device</i>
PLL	<i>Phase Lock Loop</i>
PMT	<i>Photo Multiplier Tube</i> , a vacuum tube of electrodes that multiply electrons collected and charged to create a detectable current signal
P/N (or PN)	<i>Part Number</i>

Term	Description/Definition
PSD	<i>Prevention of Significant Deterioration</i>
PTFE	<i>Poly-Tetra-Fluoro-Ethylene</i> , a very inert polymer material used to handle gases that may react on other surfaces; one of the polymers that <i>Du Pont</i> markets as <i>Teflon</i> [®]
PVC	<i>Poly Vinyl Chloride</i> , a polymer used for downstream tubing
Rdg	Reading
RS-232	specification and standard describing a serial communication method between DTE (Data Terminal Equipment) and DCE (Data Circuit-terminating Equipment) devices, using a maximum cable-length of 50 feet
RS-485	specification and standard describing a binary serial communication method among multiple devices at a data rate faster than RS-232 with a much longer distance between the host and the furthest device
SAROAD	<i>Storage and Retrieval of Aerometric Data</i>
SLAMS	<i>State and Local Air Monitoring Network Plan</i>
SLPM	<i>Standard Liters Per Minute</i> of a gas at standard temperature and pressure
STP	<i>Standard Temperature and Pressure</i>
TCP/IP	<i>Transfer Control Protocol / Internet Protocol</i> , the standard communications protocol for Ethernet devices
TEC	<i>Thermal Electric Cooler</i>
TPC	<i>Temperature/Pressure Compensation</i>
USB	<i>Universal Serial Bus</i> : a standard connection method to establish communication between peripheral devices and a host controller, such as a mouse and/or keyboard and a personal computer or laptop
VARS	<i>Variables</i> , the variable settings of the instrument
V-F	<i>Voltage-to-Frequency</i>
Z/S	<i>Zero / Span</i>