

Use and Disclosure of Data  
Information contained herein is classified as EAR99 under the  
U.S. Export Administration Regulations.  
Export, reexport or diversion contrary to U.S. law is prohibited.

# INSTRUCTIONS FOR

## Model LXT-380

### Universal Transmitter



P/N M LXT380  
Date 12-19-17



## DANGER



Toxic gases and or flammable liquids may be present in this instrument.

Personal protective equipment may be required when servicing this instrument.

Hazardous voltages exist on certain components internally which may persist for a time even after the power is turned off and disconnected.

Only authorized personnel should conduct maintenance and/or servicing. Before conducting any maintenance or servicing, consult with authorized supervisor/manager.



## EU DECLARATION OF CONFORMITY

This declaration of conformity is issued under the sole responsibility of the manufacturer

---

**APPLICATION OF COUNCIL DIRECTIVE** : 2014/34/EU

**STANDARDS TO WHICH CONFORMITY IS DECLARED** : EN 60079-0 : 2012+A11:2013; IEC 60079-0:2011  
EN 60079-1: 2014; IEC 60079-1:2014-06  
EN 60079-11: 2012; IEC60079-11:2011  
EN 60079-18:2015; IEC 60079-18:2014

**MANUFACTURER'S NAME** : TELEDYNE ANALYTICAL INSTRUMENTS

**MANUFACTURER'S ADDRESS** : 16830 Chestnut Street  
City of Industry, CA 91748  
U.S.A.

**TYPE OF EQUIPMENT** : pH, DO, Conductivity, Redox, Free Chlorine,  
Free CLO2

**EQUIPMENT CLASS** : Ex db mb [ia IIC Ga] IIC T4 Gb (Main  
Enclosure ) (-20°C ≤ Ta ≤ +55°C).  
Ex ia IIC T4 Ga (Sensor Assembly)  
(-20°C ≤ Ta ≤ +85°C).

**MODEL NUMBER** : LXT380, FCA380, CDA380

---

**I, THE UNDERSIGNED, HEREBY DECLARE THAT THE EQUIPMENT SPECIFIED ABOVE CONFORMS TO THE ABOVE STANDARD(S) PER 2014/34/EU and have been type-approved by Intertek Testing & Certification Limited, Intertek House, Cleeve Road, Leatherhead, Surrey, KT22 7SB. Intertek notified body identification number: 0359. Mark: Ex II 2 G. Code: Ex db mb [ia IIC Ga] IIC T4 Gb and Ex ia IIC T4 Ga. EC Type Certificate Number: ITS17ATEX101945X IECEx Certificate Number: IECEX ETL 17.0030X**

**SIGNATURE:** 

**FULL NAME:** Judy Thomas

**POSITION:** Quality Assurance Dir.

**Date:** 06/03/2021

**PLACE:** City of Industry, California

**SIGNATURE:** 

**FULL NAME:** Angel Alegria

**POSITION:** New Products Mngr.

**Date:** 06/03/2021

**PLACE:** City of Industry, California



## Special Conditions for Safe Use

- The end user is responsible for providing a suitably rated cable gland/seal for the electrical connection to the flameproof enclosure.
- The end user should ensure that the equipment is not installed in a location where it may be subjected to external conditions (such as high-pressure steam) which might cause a build-up of electrostatic charges on non-conducting surfaces. Additionally, cleaning of the equipment should be done only with a damp cloth.
- Flame-paths are not intended to be modified.



## Copyright © 2017 Teledyne Instruments/ Analytical Instruments

All Rights Reserved. No part of this manual may be reproduced, transmitted, transcribed, stored in a retrieval system, or translated into any other language or computer language in whole or in part, in any form or by any means, whether it be electronic, mechanical, magnetic, optical, manual, or otherwise, without the prior written consent of Teledyne Instruments/ Analytical Instruments, 16830 Chestnut Street, City of Industry, CA 91748.

### Warranty

This equipment is sold-subject to the mutual agreement that it is warranted by us free from defects of material and of construction, and that our liability shall be limited to replacing or repairing at our factory (without charge, except for transportation), or at customer plant at our option, any material or construction in which defects become apparent within one year from the date of shipment, except in cases where quotations or acknowledgements provide for a shorter period. Components manufactured by others bear the warranty of their manufacturer. This warranty does not cover defects caused by wear, accident, misuse, neglect or repairs other than those performed by TI/AI or an authorized service center. We assume no liability for direct or indirect damages of any kind and the purchaser by the acceptance of the equipment will assume all liability for any damage which may result from its use or misuse.

We reserve the right to employ any suitable material in the manufacture of our apparatus, and to make any alterations in the dimensions, shape or weight of any parts, in so far as such alterations do not adversely affect our warranty.

### Important Notice

This instrument provides measurement readings to its user, and serves as a tool by which valuable data can be gathered. The information provided by the instrument may assist the user in eliminating potential hazards caused by his process; however, it is essential that all personnel involved in the use of the instrument or its interface, with the process being measured, be properly trained in the process itself, as well as all instrumentation related to it.

The safety of personnel is ultimately the responsibility of those who control process conditions. While this instrument may be able to provide early warning of imminent danger, it has no control over process conditions, and it can be misused. In particular, any alarm or control systems installed must be tested and understood, both as to how they operate and as to how they can be defeated. Any safeguards required such as locks, labels, or redundancy, must be provided by the user or specifically requested of TI/AI at the time the order is placed.

Therefore, the purchaser must be aware of the hazardous process conditions. The purchaser is responsible for the training of personnel, for providing hazard warning methods and instrumentation per the appropriate standards, and for ensuring that hazard warning devices and instrumentation are maintained and operated properly.

Teledyne Instruments/ Analytical Instruments, the manufacturer of this instrument, cannot accept responsibility for conditions beyond its knowledge and control. No statement expressed or implied by this document or any information disseminated by the manufacturer or its agents, is to be construed as a warranty of adequate safety control under the user's process conditions.

## **Specific Model Information**

**Instrument Serial Number:** \_\_\_\_\_

Sample Gas 1: \_\_\_\_\_

Zero Gas: \_\_\_\_\_

Span Gas: \_\_\_\_\_



### Safety Messages

---

Your safety and the safety of others is very important. We have provided many important safety messages in this manual. Please read these messages carefully.

A safety message alerts you to potential hazards that could hurt you or others. Each safety message is associated with a safety alert symbol. These symbols are found in the manual and inside the instrument. The definition of these symbols is described below:



**GENERAL WARNING/CAUTION:** Refer to the instructions for details on the specific danger. These cautions warn of specific procedures which if not followed could cause bodily Injury and/or damage the instrument.



**CAUTION: HOT SURFACE WARNING:** This warning is specific to heated components within the instrument. Failure to heed the warning could result in serious burns to skin and underlying tissue.



**WARNING: ELECTRICAL SHOCK HAZARD:** Dangerous voltages appear within this instrument. This warning is specific to an electrical hazard existing at or nearby the component or procedure under discussion. Failure to heed this warning could result in injury and/or death from electrocution.



*Technician Symbol:* All operations marked with this symbol are to be performed by qualified maintenance personnel only.

No  
Symbol

*NOTE:* Additional information and comments regarding a specific component or procedure are highlighted in the form of a note.



**CAUTION:** THIS INSTRUMENT SHOULD ONLY BE USED FOR THE PURPOSE AND IN THE MANNER DESCRIBED IN THIS MANUAL.



**IF YOU USE THIS EQUIPMENT IN A MANNER OTHER THAN THAT FOR WHICH IT WAS INTENDED, UNPREDICTABLE BEHAVIOR COULD RESULT POSSIBLY ACCOMPANIED WITH HAZARDOUS CONSEQUENCES.**

This manual provides information designed to guide you through the installation, calibration operation and maintenance of your new analyzer. Please read this manual and keep it available.

Occasionally, some instruments are customized for a particular application or features and/or options added per customer requests. Please check the front of this manual for any additional information in the form of an Addendum which discusses specific information, procedures, cautions and warnings that may be peculiar to your instrument.

Manuals do get lost. Additional manuals can be obtained from TI/AI at the address given in the Appendix. Some of our manuals are available in electronic form via the internet. Please visit our website at: [www.teledyne-ai.com](http://www.teledyne-ai.com).

## Table of Contents

---

<b>List of Figures .....</b>	<b>xi</b>
<b>List of Tables .....</b>	<b>xii</b>
<b>1.0 Introduction .....</b>	<b>1</b>
1.1 MODEL LXT-380 TRANSMITTER	1
1.2 BARRIER 9120019	2
1.3 STOPPING PLUG 9310062	3
1.4 SP3X SENSOR	3
1.5 FEATURES	4
1.6 SPECIFICATIONS	5
1.6.1 INPUT SPECIFICATION	5
1.6.2 INPUT RANGES	5
1.6.3 ACCURACY	5
1.6.4 OUTPUT SIGNALS	5
1.6.5 CONTACT RELAYS	6
1.6.6 DISPLAY	6
1.6.7 ENCLOSURE	6
1.6.8 POWER	6
1.6.9 ENVIRONMENTAL CONDITIONS	6
1.6.10 SHIPPING	6
1.7 MODEL CODES	7
1.8 APPROVALS	8
1.8.1 ENCLOSURE	8
<b>2.0 INSTALLATION .....</b>	<b>9</b>
2.1 MOUNTING	9
2.2 WIRING	10
2.2.1 WIRING, POWER	12

## LXT-380 Universal Transmitter

---

2.2.2 WIRING, BARRIER 9120019	12
2.2.3 WIRING, SENSOR SP3X	14
2.2.4 WIRING, 4-20 MA OUTPUTS	15
2.2.5 WIRING, CONTACT RELAY OUTPUTS	15
2.2.6 WIRING, SERIAL OUTPUT MODBUS RTU	16
<b>3.0 OPERATION .....</b>	<b>17</b>
3.1 MAGNETIC KEYS	17
3.1.1 HOME/EXIT KEY	18
3.1.2 BACK/HOLD KEY	18
3.1.3 SELECTION ADJUSTMENT KEYS	19
3.1.4 ALPHA NUMERIC ENTRY	19
3.2 MENU STRUCTURE	19
3.2.1 HOLD (OUTPUT HOLD)	21
3.2.2 CAL (CALIBRATION MENU)	21
3.2.3 CONFIG (CONFIGURATION MENU)	22
3.2.4 INFO (INFORMATION MENU)	25
3.2.5 SIM (SIMULATION MENU)	26
3.2.6 FAULT SCREENS	27
3.2.7 SENTINEL <sup>®</sup> SCREENS	27
3.3 START UP GUIDE	28
3.3.1 CONFIGURE 4-20 MA OUTPUT RANGE	29
3.3.2 CONFIGURE 4-20 MA FAULT CONDITION AND CAL	29
3.3.3 CONFIGURE ALARM RELAYS (RELAYS OPTIONAL)	30
3.3.4 EXIT MENUS AND RETURN TO MAIN DISPLAY	31
3.3.5 SENSOR START UP	32
3.4 USER SELECTABLE OPTIONS	32
3.4.1 SCREEN LIGHTING	32
3.4.2 GRAPHICAL DISPLAY	32
3.4.3 TAG TRANSMITTER NAME	33
3.4.4 SENSOR NAME	34
3.4.5 PASSWORD PROTECTION	34
<b>4.0 CALIBRATION.....</b>	<b>37</b>

## LXT-380 Universal Transmitter

---

4.0.1 AUTO CALIBRATION DESCRIPTION	37
4.0.2 STANDARDIZE CALIBRATION DESCRIPTION	38
4.0.3 MANUAL CALIBRATION DESCRIPTION	38
4.1 pH CALIBRATION PROCEDURES	39
4.1.1 AUTO CAL USING pH 4.01, 7.00, 10.00 BUFFERS	39
4.1.2 AUTO CAL USING OTHER PH BUFFERS	40
4.1.3 STANDARDIZE	40
4.2 ORP CALIBRATION PROCEDURES	41
4.2.1 AUTO CAL WITH QUINHYDRONE	41
4.2.2 STANDARDIZE	41
4.3 PION CALIBRATION PROCEDURES	42
4.3.1 AUTO CAL USING 1, 10, 100 PPM SOLUTIONS	42
4.3.2 AUTO CAL USING NON-DECIMAL PPM SOLUTIONS	42
4.3.3 STANDARDIZE	43
4.4 SP3X DISSOLVED OXYGEN CALIBRATION PROCEDURES	43
4.5 CONDUCTIVITY SENSORS	45
4.5.1 AUTO CAL USING AIR AND CONDUCTIVITY STANDARD	45
4.5.2 STANDARDIZE	46
4.6 TDS CONDUCTIVITY SENSORS	46
4.6.1 STANDARDIZE	47
4.7 RESISTIVITY SENSORS	47
4.7.1 AUTO CAL USING AIR AND MEG-OHM PROCESS WATER	48
4.7.2 STANDARDIZE	48
<b>5.0 MAINTENANCE</b> .....	<b>49</b>
5.1 CLEANING	49
5.2 REPAIR/SERVICE	49
<b>6.0 TROUBLESHOOTING</b> .....	<b>51</b>
<b>7.0 PARTS AND ACCESSORIES</b> .....	<b>53</b>
7.1 REPLACEMENT PARTS	53

<b>8.0 SP3X SENSORS.....</b>	<b>55</b>
8.1 SP3X INSTALLATION	55
8.1.1 INSERTION	55
8.1.2 IMMERSION	56
8.1.3 FLOW THROUGH	56
8.1.4 VALVE RETRACTABLE	56
8.1.5 FLANGE FITTINGS	58
8.2 SP3X PART NUMBER CONFIGURATOR	58
8.3 SP3X SENSOR MAINTENANCE	60
8.3.1 ELECTRODE CARTRIDGE INSTALLATION	61
8.3.2 ELECTRODE CARTRIDGE REPLACEMENT	61
8.3.3 ELECTRODE CLEANING	62
8.3.4 PH ELECTRODE CARTRIDGE CLEANING	62
8.3.5 ORP ELECTRODE CARTRIDGE CLEANING	62
8.3.6 PION ELECTRODE CARTRIDGE CLEANING	63
8.3.7 DISSOLVED OXYGEN CARTRIDGES	64
8.3.8 CONDUCTIVITY AND RESISTIVITY SENSORS	65
8.4 SP3X SENSOR SPECIFICATIONS	65
8.4.1 PH ELECTRODES	66
8.4.2 ORP ELECTRODES	66
8.4.3 DISSOLVED OXYGEN	67
8.4.4 AMMONIUM ELECTRODE	67
8.4.5 BROMIDE ELECTRODE	67
8.4.6 CALCIUM ELECTRODE	67
8.4.7 CHLORIDE ELECTRODE	68
8.4.8 CUPRIC ELECTRODE	68
8.4.9 CYANIDE ELECTRODE	68
8.4.10 FLUORIDE ELECTRODE	69
8.4.11 POTASSIUM ELECTRODE	69
8.4.12 SILVER ELECTRODE	69
8.4.13 SODIUM ELECTRODE	69
8.4.14 SULFIDE ELECTRODE	70

## LXT-380 Universal Transmitter

---

<b>Appendix.....</b>	<b>71</b>
A. Auto Cal Buffer Tables	71
B. LXT-380 Hart Menu	72
C. MODBUS RTU REGISTER LISTING	74
D. RESISTIVITY TEMPERATURE COMPENSATION	81
E. Drawings	82
F. Company Address	85

**List of Figures**

---

Figure 2-1: Dimensions SS Housing ..... 10  
Figure 2-2: LXT-380 Transmitter Wiring Terminals ..... 11  
Figure 2-3: B80 Barrier Wiring..... 13  
Figure 2-4: SP3X Sensor Connector Wiring ..... 14  
Figure 2-5: Wiring for HART® Communication..... 15  
Figure 3-1: LXT-380 Screen Map ..... 20



## List of Tables

---

Table 1 Saturation Index .....	44
Table 2 Altitude Correction.....	45



**This is a general purpose instrument designed for use in a non-hazardous area. It is the customer's responsibility to ensure safety especially when combustible gases are being analyzed since the potential of gas leaks always exist.**

**The customer should ensure that the principles of operating this equipment are well understood by the user. Misuse of this product in any manner, tampering with its components, or unauthorized substitution of any component may adversely affect the safety of this instrument.**

**Since the use of this instrument is beyond the control of Teledyne Analytical Instruments, referred as TAI, no responsibility by TAI, its affiliates, and agents for damage or injury from misuse or neglect of this equipment is implied or assumed.**

**Blank Page**

## 1.0 Introduction

---



The Teledyne Model LXT-380 transmitter is a single or dual channel, intelligent, multiparameter transmitter designed for the online continuous measurement of pH, ORP, pION, dissolved oxygen, conductivity, resistivity and in a hazardous industrial environment. The Model LXT-380 transmitter communicates digitally with any Teledyne SP3X digital sensor, automatically configuring the transmitter's menus and display screens to the measured parameter.

The Model LXT-380 transmitter can be loop powered or 24 VDC powered. The standard configuration has a 4-20 mA output and a RS485 serial communication port with MODBUS<sup>®</sup> RTU output. A HART<sup>®</sup> communication version (single channel version only) is also available. Alarm relays are optionally available on any 24 VDC powered transmitter.

### 1.1 MODEL LXT-380 TRANSMITTER

IECEX: ETL 17.0030X

ATEX: ITS17ATEX101945X

  1180 II 2 G Ex db mb [ja IIC Ga] IIC T4 Gb

This Model LXT-380 Transmitter is intended for installation in hazardous locations with Zone 1, Ex db mb Gb classification. Ambient temperature conditions must be within  $-20^{\circ}\text{C} \leq T_a \leq +55^{\circ}\text{C}$  to comply with product approval.



Power connections into the transmitter must be made with flame-proof conduit and cable glands certified for hazardous locations and compatible with Ex db mb Gb certified equipment.

- Ensure installation complies with all local, state and national codes for the installation of this equipment in hazardous locations.
- Refer to Control Drawing T1700004 (see Appendix) for specific installation requirements.
- Do not install any equipment approved for non-hazardous locations in a hazardous area.
- Do not install this equipment into a Zone 0 location.
- Substitution of components is NOT PERMITTED and may impact intrinsic safety.

## 1.2 BARRIER 9120019

IECEX: DNV 14.0024X

ATEX: DNV 14ATEX4192X

 1180  I M2 (M1) Ex db mb [ia Ma] I Mb

Barrier part number 9120019 is intended for installation in hazardous locations with Zone 1, Ex d Gb classification. The barrier is installed into the LXT-380 flame-proof housing and performs two important functions. First, the barrier provides a flame-proof termination between the Model LXT-380 Transmitter Model SP3X Sensor. Second, the barrier provides intrinsically safe outputs to the SP3X Sensor by limiting available energy to the SP3X Sensor. The barrier may not be modified, altered or substituted with any components which may impair the safety of the system.

- Ensure the installation complies with all local, state and national codes for the installation equipment in hazardous locations.
- Refer to Control Drawing T1700004 for specific install requirements. (See Appendix).
- Do not install equipment approved for non-hazardous locations in a hazardous area.

- Do not install this equipment into a Zone 0 location.
- Substitution of components is NOT PERMITTED and may impact intrinsic safety.
- Ensure a minimum 5 full threads of engagement.
- Connect and verify green wire to LXT-380 grounding lug.

### 1.3 STOPPING PLUG 9310062

IECEX: SIR 07.0082X

ATEX: SIRA 07ATEX1240X

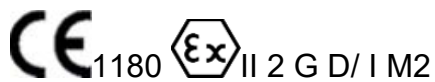

Ex d I/II C, Ex e I/II

Ex tD A21 IP6X

Stopping plug P/N 9310062 is intended for installation in hazardous locations with Zone 1, Ex d Gb classification. The plug is factory installed into the LXT-380 flame-proof housing to maintain the flame-proof integrity for unused wiring ports in single channel configuration. Do not remove or modify the plug or flame-path of the plug. Verify that the plug is tightened to a torque of 55Nm (41ft-lbs).

- Ensure the installation complies with all local, state and national codes.
- Refer to Control Drawing T1700004 for specific install requirements. (See Appendix).
- DO NOT substitute or alter this component as it may impact flame-proof integrity.

### 1.4 SP3X SENSOR

IECEX: ETL 17.0030X

ATEX: ITS17ATEX101945X

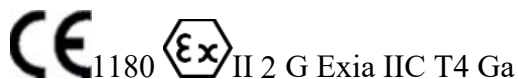

The Model SP3X Sensor is intrinsically safe and intended for installation in hazardous locations with Zone 0, Ex ia Ga classification. Energy available to the sensor is limited by the barrier to intrinsically safe levels. The maximum stored energy in the SP3X Sensor is below the level needed to generate spark ignition of the environment under any condition. Ambient temperature conditions must within  $-20^{\circ}\text{C} \leq T_a \leq +85^{\circ}\text{C}$  to comply with the product approval.

- Ensure that the installation complies with all local, state and national codes for the installation of this equipment in hazardous locations.
- Refer to Control Drawing T1700004 for specific installation requirements. (See Appendix).
- Do not install any equipment approved for non-hazardous locations in a hazardous area.
- Substitution of components is NOT PERMITTED and may impact intrinsic safety.
- To avoid the danger of electrostatic charging, the SP3X sensor must be installed into a tank, vessel, piping or other liquid containment structure that is electrostatically connected to ground.

## 1.5 FEATURES

- Multi-Parameter, pH, ORP, Specific Ion, Dissolved Oxygen, Conductivity, Resistivity
- Simple, user friendly menu structure
- Noise free digital communication with sensors
- Reads and writes calibration data to sensor
- Dual Channel option has interactive channels, pH compensated readings, interfering ion corrections
- A 4-20mA output and MODBUS<sup>®</sup> RTU is standard, HART<sup>®</sup> is optional

## 1.6 SPECIFICATIONS

### 1.6.1 INPUT SPECIFICATION

Digital protocol, all Teledyne SP3X Sensors

### 1.6.2 INPUT RANGES

pH	-1.00 - 15.00 pH
ORP	-1500 - +1500 mV
pION	000.1 - 999.9, Auto Ranging: ppb ↔ ppm ↔ ppt (thousand)
Dissolved Oxygen	000.1 - 999.9, Auto Ranging: ppb ↔ 20.00 ppm, % SAT, mg/L
Conductivity	0.000 - 2.000, Auto Ranging: μS ↔ mS ↔ S
TDS	0.00 - 9999 ppm
Resistivity	0.00 - 50.00 MO
Temperature	100 K-ohm TC, -20°C + 85°C

### 1.6.3 ACCURACY

pH	0.02 pH
ORP	± 1 mV
pION	Specific to electrode type
Dissolved Oxygen	2% of range
Conductivity	2% of range
Resistivity	2% of range
Temperature	± 0.3°C

### 1.6.4 OUTPUT SIGNALS

4-20 mA output	(standard, one per Channel), Fault Condition: 3.5 mA, 22 mA or none
Modbus RTU	(standard)
HART®	(optional)



### 1.6.5 CONTACT RELAYS

(Optional) Three (3) SPDT, 1 form C, 250 VAC, 10 Amp resistive maximum, relays, user configurable as Hi/Lo alarms with expiration timer, Periodic Timers or Fault alarms.

### 1.6.6 DISPLAY

128 x 64 pixels (2.0" x 1.1") LCD, Black on Grey background on loop powered instruments, Blue on White background with LED backlight on 24 VDC powered instruments, English, numeric and graphical displays.

### 1.6.7 ENCLOSURE

Explosion Proof	Certified: FM, CSA, ATEX and IECEx
Materials:	Electro Polished 316 SS
Mounting:	2 x M4 (3/16") and 3 x 3/4" FNPT

### 1.6.8 POWER

Code -0	Loop powered, 24 VDC 600 $\Omega$ maximum load (18-36VDC @ 35 mW minimum)
Code -1	24 VDC (18-36 VDC @ 250 mW minimum)

### 1.6.9 ENVIRONMENTAL CONDITIONS

Outdoor use:	(IP65)
Ambient Temp.:	-20°C to +55°C
Storage Temp.:	-30°C to +85°C
Relative Humidity:	0 – 80%, up to 31°C Decreasing linearly to 50% RH at 40°C
Altitude:	Up to 2000 m (6500 Ft.)

### 1.6.10 SHIPPING

Size:	5.5" x 5.1" x 5" (14 cm x 13 cm x 12.7 cm)
Weight:	316 SS, 8.0 lbs. (3.65 kg)

**1.7 MODEL CODES**

<b>Model LXT-380-</b>						
1st channel:	<b>1</b> (SP3X) SP3X Digital Sensor, pH, ORP, pION, DO, DO90 ppb DO, Conductivity, Resistivity					
	2nd Channel	<b>0</b> No Second Channel				
		<b>1</b> (SPX3) SPX3 Digital Sensor, pH, ORP, pION, DO, Conductivity, Resistivity				
	Power Supply	<b>-0</b> Loop Powered Transmitter				
		<b>-1</b> 24 VDC Powered Transmitter				
	Relay Option	<b>0</b> No Relays				
		<b>1</b> (3) for 1C 250 V 3A Relays				
		Outputs	<b>0</b> 4-20 mA output and Modbus			
	<b>1</b> HART®					
	<b>2</b> x 4-20 mA & MODBUS					
						<b>00</b> No Mounting
<b>Model LXT-380</b>	<b>1</b>	<b>1</b>	<b>-2</b>	<b>1</b>	<b>2</b>	<b>00</b>

The above example shows part# LXT380-11-112-00: a two channel LXT-380 transmitter for use with two SP3X sensors, 24 VAC powered with two 4-20 mA outputs and MODBUS RTU and no mounting bracket.

## 1.8 APPROVALS

### 1.8.1 ENCLOSURE

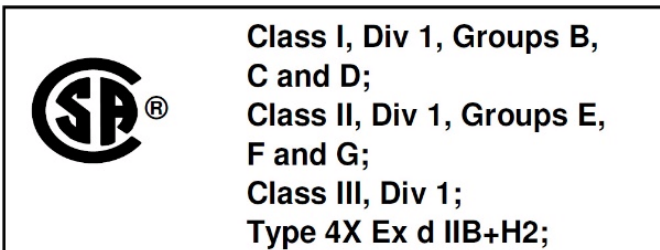
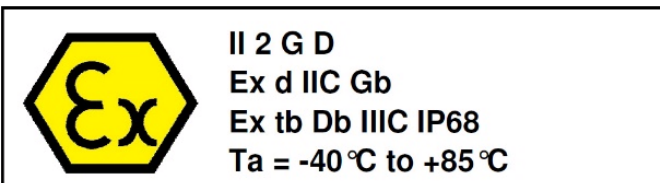
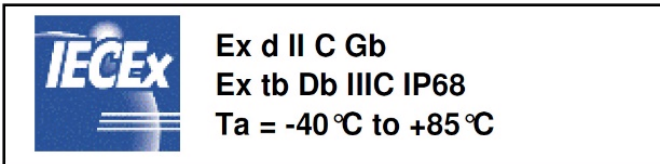
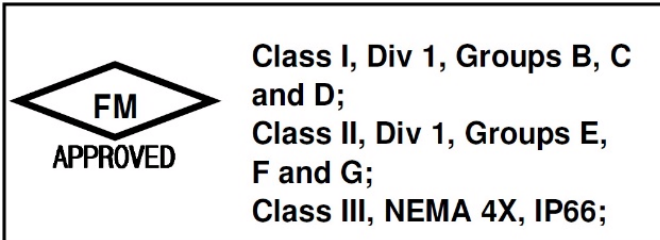

## 2.0 INSTALLATION

### 2.1 MOUNTING

Mount the LXT-380 in a location where there is easy access to the analyzer and sensors. Install the system in an area where vibrations, electromagnetic and radio frequency interference are minimized or absent. Do not mount in direct sunlight or areas of extreme heat. The IP65 LXT-380 is suitable for outdoor use but it is best to mount it with a protective cover or sunshield to prevent discoloring over the years.

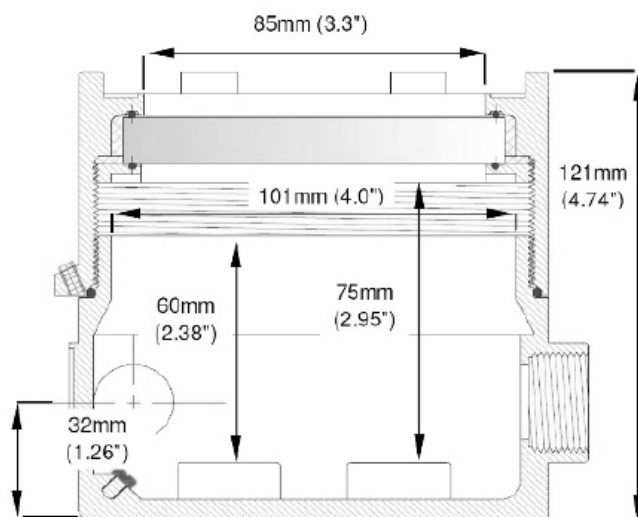

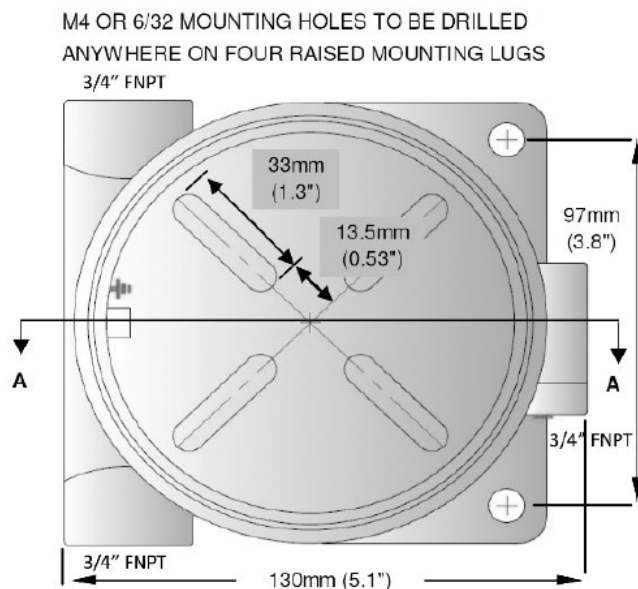

Figure 2-1: Dimensions SS Housing

## 2.2 WIRING

The LXT-380 installation consists of a flame-proof transmitter with enclosure; an integral intrinsically-safe energy limiting barrier and flame-proof seal; and an Intrinsically-safe sensor. Substitution of parts or unauthorized repairs are prohibited and will invalidate certification. Examples of unauthorized repairs include flame-path alteration or modification of flame-proof components. Omission of components, including but not limited to flame-proof conduit, flame-proof seals and stopping plugs is not permitted. Flame-proof stopping plug shall be tightened to a specified torque of 55Nm (41ft-lbs). Refer to local, state and national codes for specific installation requirements and refer to additional documents as necessary (NFPA33, NEC 500 and 516, IEC 60079-14).

Electrical wiring should only be conducted by qualified personnel. See the LXT-380 Wiring Diagram in Figure 2.2.

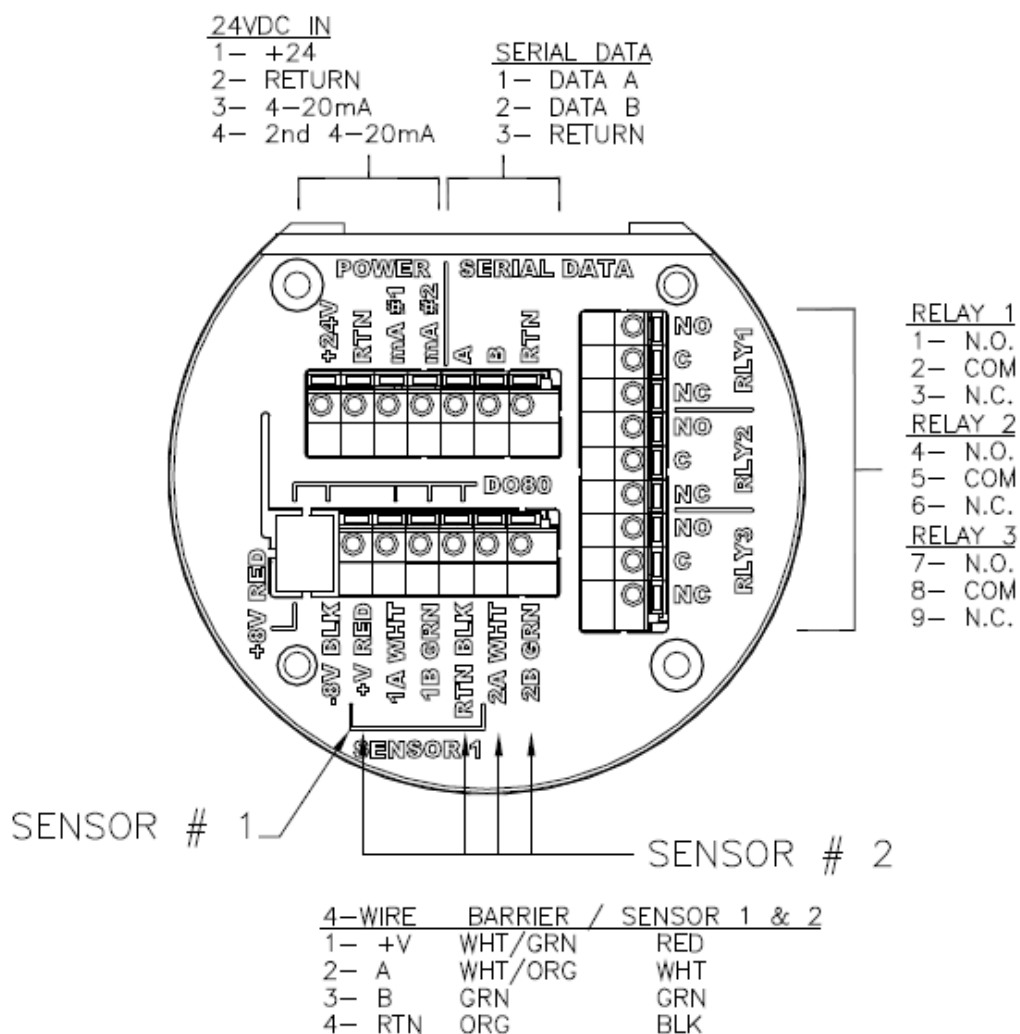

Figure 2-2: LXT-380 Transmitter Wiring Terminals

**WARNING: RISK OF ELECTRICAL SHOCK**  
**DISCONNECT POWER BEFORE OPENING**  
**INSTRUMENT.**



**WARNING** ELECTRICAL INSTALLATION MUST BE IN ACCORDANCE WITH THE NATIONAL ELECTRICAL CODE (ANSI/NFPA-70), CANADIAN ELECTRICAL CODE AND/OR ANY OTHER APPLICABLE NATIONAL OR LOCAL CODES.



### **2.2.1 WIRING, POWER**

Field connections, including input power and user wiring is to be supplied via conduit suitable for the environment classification. Mount the enclosure and connect with conduit as per the conduit manufacturers recommendations. Pull wiring thru the conduit and attach to the terminals listed below. Tighten all joints and seal the conduit as required to ensure compliance with installation requirements.

#### **Loop Powered (2 wire configuration)**

Attach the 24VDC signal cable to terminals #1 and #2 as shown in Figure 2.2 and on the diagram inside of the LXT-380 cover. Feed the cable through the gland fitting on the left hand side of the LXT-380. Tighten the cable gland to provide a good seal to the cable. The instrument can be powered up at this point with no harm to the analyzer but it is best to wait until the sensor is installed.

#### **24VDC (4 wire configuration)**

Attach the 24VDC power cable to terminals #1 and #2 as shown in Figure 2.2 and on the diagram inside of the LXT-380 cover. Attach the 4-20 mA1 cable to terminals #3 (out) and #2 (return) single channel unit and attach the 4-20 mA2 cable to terminals #4 (out) and #2 (return) for a two channel instrument. Feed the cables through the gland fitting on the left hand side of the LXT-380. Tighten the cable gland to provide a good seal to the cable.

The instrument can be powered up at this point with no harm to the analyzer but it is best to wait until the sensor is installed.

### **2.2.2 WIRING, BARRIER 9120019**

Pass the barrier cable thru the selected  $\frac{3}{4}$ " NPT port and tighten to complete flameproof Ex-d seal. Ensure at least 5 full threads of engagement. Insert the corresponding wires into the terminal block locations identified below. For single channel configurations, connect the White/Green wire to position +V RED above the label Sensor #1. Connect the White/Orange wire to position 1A WHT and connect the Green wire to the 1B GRN position. Connect the Orange wire to the RTN BLK position. Connect Green Grounding wire to the chassis

ground lug provided inside the LXT-380 housing. If the installation is a single channel unit remember to install the sealing plug (supplied) and tighten to 55nM (41ft-lbs) to maintain the flameproof integrity.

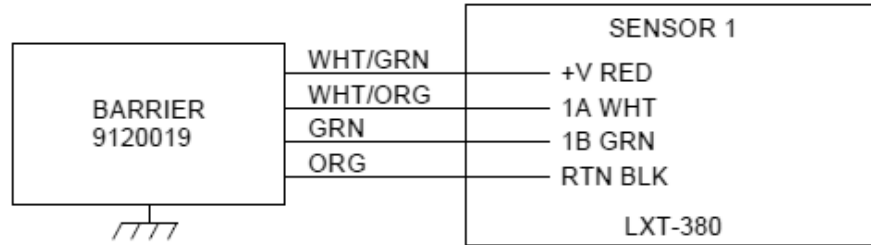

LXT-380 SINGLE CHANNEL SENSOR WIRING

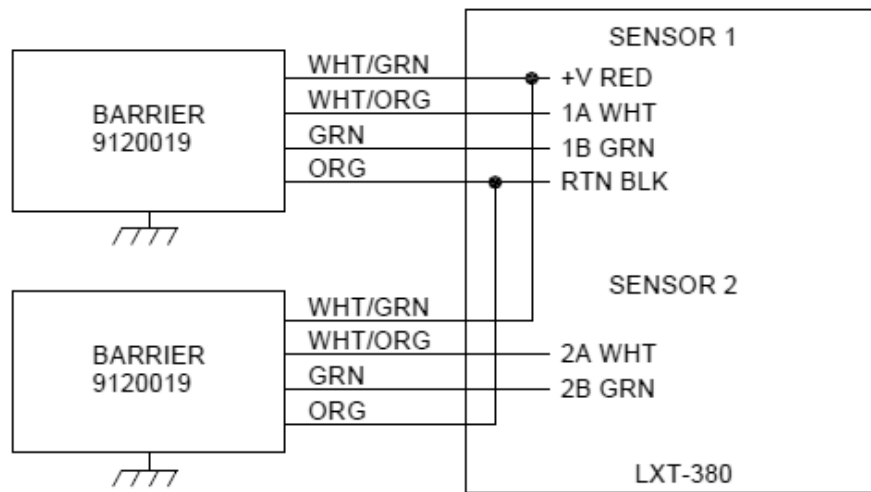

LXT-380 DUAL CHANNEL SENSOR WIRING

*Figure 2-3: B80 Barrier Wiring*



**2.2.3 WIRING, SENSOR SP3X**

Mount the SP3X sensor into the process as needed. Route the sensor cabling and attach the connector as follows (See Figure 2-4 SP3X Sensor Connector Wiring): Slide parts onto cable including Backshell, Clamping Cage, Gromet and Shielding Ring. Strip wire insulation as indicated below and slide into Housing. Gently tighten the Backshell to the Housing to fix the cable. Insert the individual wire conductors into the location identified:

White=1; Red=2; Black=3; and Green=4. Tighten the four (4) screws to secure the conductors. Slide the Housing forward and attach it to the Plug assembly. Tighten the Housing and Backshell to secure the connector. Insert the plug into the Barrier and rotate the knurl counter-clockwise to complete the installation.

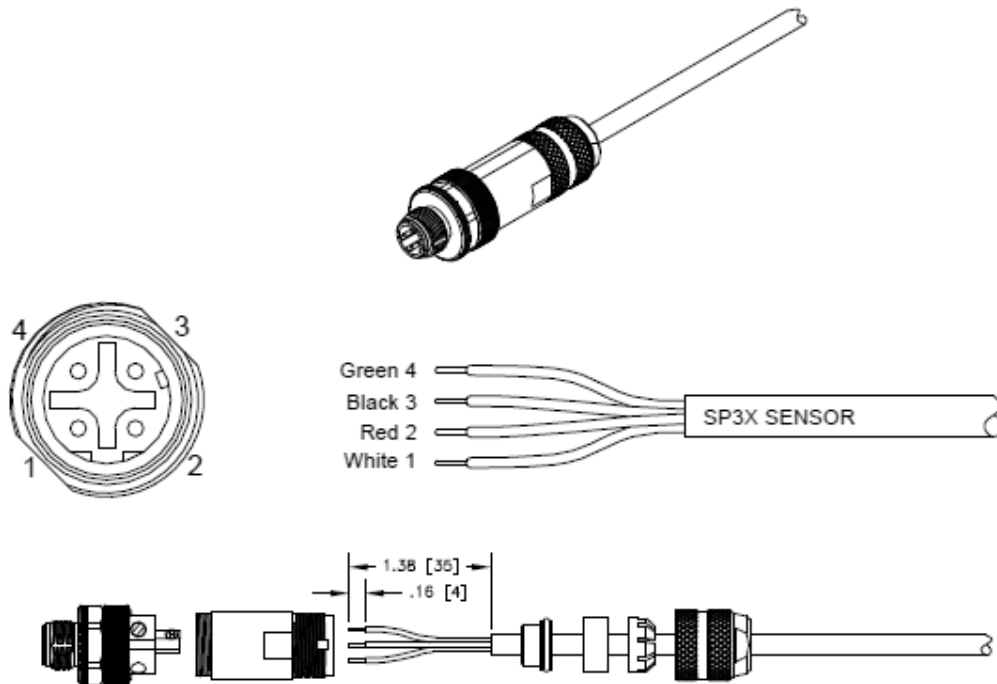

*Figure 2-4: SP3X Sensor Connector Wiring*

### 2.2.4 WIRING, 4-20 MA OUTPUTS

#### Loop Powered Instruments:

Connect the 4-20 mA cable to terminals #1 (+24V) and #2 (GND), Model LXT-380-XX-0 X-XX.

#### 24 VDC powered instruments:

For instruments powered by 24VDC (Model LXT-380-XX-1X-XX), connect the 4-20 mA cable(s) to terminals #3 (out) for channel 1 and #2 (return) and to terminals #4 (out) for channel 2 and #2 (return).

Transmitters with HART® Communication can be wired as shown below. See HART® Communication menu in Appendix 9.2:

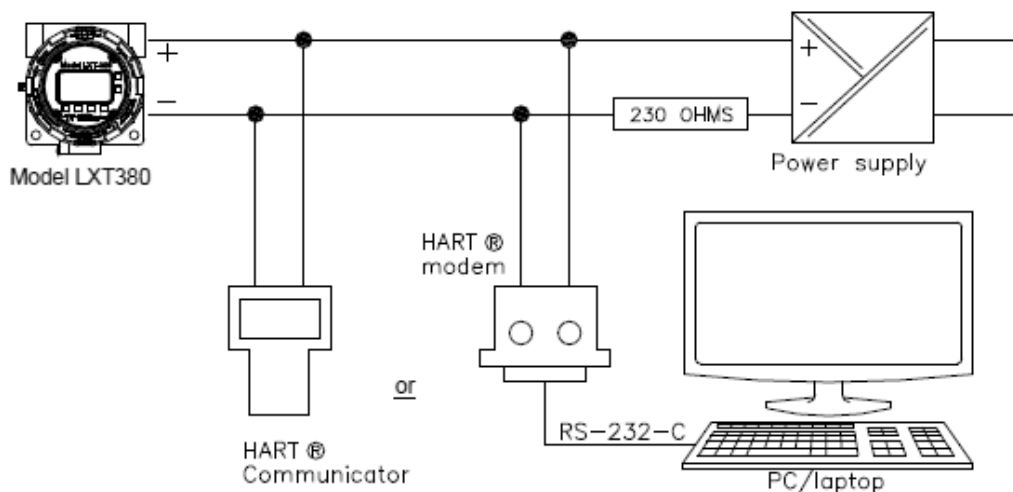

Figure 2-5: Wiring for HART® Communication

### 2.2.5 WIRING, CONTACT RELAY OUTPUTS

The standard configuration has three SPDT 230V 5 A relays that can be wired either **normally open (NO)** or **normally closed (NC)**. The default configuration is set to use the relays as normally open.

**2.2.6 WIRING, SERIAL OUTPUT MODBUS RTU**

Attach the sensor wires as shown in Figure 2-2 or as described on the diagram inside the LXT-380 cover. Feed the sensor cable through the gland fitting on the left hand side of the LXT-380. Do not use the same gland fitting for the AC power or Alarm/Relays. See MODBUS command register in Appendix D.

### 3.0 OPERATION

---

The Model LXT-380 transmitter communicates digitally with any Teledyne SP3X digital sensor. The measurement identity is contained in the sensor's memory. When an SP3X sensor is connected to the transmitter it automatically configures the transmitter's menus and display screens to the measured parameter.



#### 3.1 MAGNETIC KEYS

The keys on the Model LXT-380 transmitter are magnetic Hall Effect switches.

Use the magnetic end of the supplied instrument screw driver to actuate the switches. Bringing the magnet within 1/4" (6 mm) of the key will trigger the switch. The functions associated with each key are displayed on the screen, above or beside the key for the Selection Adjustment Keys and to the left of the key for the HOME and BACK keys. **Actuate any Selection Adjustment key twice within one second to enter the HOME Menu Screen.**

**3.1.1 HOME/EXIT KEY**

The **HOME** key performs two functions, it selects which Home Screen is displayed and it returns the active screen to the HOME Menu Screen from anywhere inside the menu structure.

**Three Display screens** are available:

1. **DATA SCREEN:** Displays the measurement type, numerical value, engineering Units, % Output of the 4-20 mA channel and temperature.
2. **mV SCREEN:** Displays the measurement type, the sensor’s raw millivolt Value, % Output of the 4-20 mA channel and temperature.
3. **GRAF SCREEN:** Displays a Graphical representation of the 4-20 mA channel % Output, the measurement type, the engineering units, and temperature. Only one of the three graphical display styles is available through the HOME key, either the Bar, Gauge or Line display. Choose which style will be displayed in the Graph Menu. (pathway to Graph Menu: CONFIG → XMTR → LCD → Graph menu)

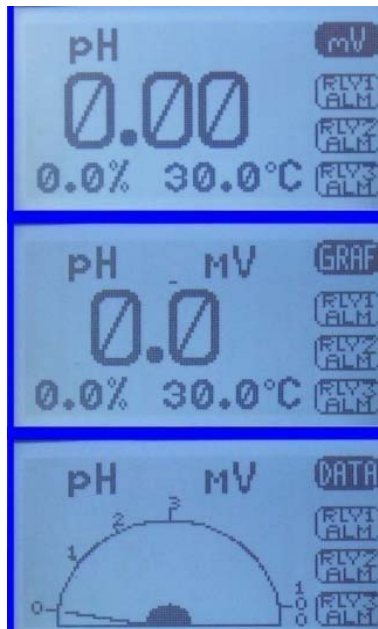

Each of the above screens also displays the condition of the optional Alarm Relays, black if energized and white if de-energized.

The HOME key changes to the **EXIT** key in the HOME Menu Screen, pressing EXIT prompts the user to “Save Changes” YES/NO when exiting the HOME Menu. YES applies any changes made in the menus, NO exits the HOME Menu without applying any changes made in the menus.

**3.1.2 BACK/HOLD KEY**

The **BACK** key changes the screen to the previously displayed screen when inside a menu, it moves BACK one screen. On a dual channel transmitter it toggles between the PV1, PV2 and Dual Channel Screens. The **HOLD** key toggles the output



HOLD function ON/OFF in the MENU HOME screen.

### 3.1.3 SELECTION ADJUSTMENT KEYS

The (4) Selection/Adjustment keys allow navigation and numerical adjustments to be made in the MENUs. **To enter the HOME Menu screen actuate any of the Selection/Adjustment keys twice within one second.** The various Menu choices and adjustment tools are displayed above the buttons once inside the MENU.

### 3.1.4 ALPHA NUMERIC ENTRY

The LABEL and PASSWORD (Caps and Numbers only) Menus allow alphanumeric entry. Entry is accomplished by scrolling through the alphanumeric list with the ▲ (forward) and ▼ (backwards) arrows to the character of choice and then moving to the NEXT digit. Actuating and holding the ▲ or ▼ keys will initiate two speed auto scrolling. The character set is sequentially listed below. The first character in the set is an empty space.

! ” # \$ % & ‘ ( ) \* + , - . / 0 1 2 3 4 5 6 7 8 9 : ; < = > ? @ A B C D  
E F G H I J K L M N O P Q R S T U V W X Y Z [ ¥ ] ^ \_ ‘ a b c d e f g h  
I j k l m n o p q r s t u v w x y z { | } → ←

## 3.2 MENU STRUCTURE

There are 4 main function screens on the LXT-380 with numerous subfunctions and screens. Figure 3-1 is a screen map of the LXT-380 display.

<b>CAL</b> <b>(Calibration)</b>	Auto	Cal 1 (Offset) using Calibration Solution			
		Cal 2 (Slope) using Calibration Solution			
	Standardize	Enter Grab Sample Determined Value			
	Manual	Enter Offset, the PV value and associated mV			
		Enter Slope, mV/pH, mV/decade, mV/ppm...			
Temp	Enter measured Temperature				
<b>CONFIG</b> <b>(Configuration)</b>	XMTR	LCD	Set Up	Temp. Format	°C or °F
				Contrast	Adj. 0-100%
				Back Light	Enter ON time
				Range Lock	Choose: Auto, ppb, ppm, ppt
			Graph	Line	Screen Duration
				Gauge	
				Bar	
			Label	TAG ID	Enter Name
				TAG	ON/OFF
		POP UP		ON/OFF	
		SENSOR		Enter Name	
		Output	4-20 mA (1 or 2)	Range (PV or Temp.)	4 mA = 20 mA =
				Cal (more)	Trim 4.00 mA Trim 20.00 mA
				Fault (more)	3.5 mA 22 mA NONE
				RELAY	Relay 1
	Timed		Period, Duration		
	Fault				
	Relay 2		Alarm	Set Point	
			Timed	Period, Duration	
	Fault				
	Relay 3		Alarm	Set Point	
		Timed	Period, Duration		
	Fault				
	HOLD	Time out: None, 15 min, 30 min...			
	Serial	Address			
		Baud rate			
		Format			
	Password	Menu	Off/On " _ _ _ _ "		
		CAL	Off/On " _ _ _ _ "		
		CNFG	Off/On " _ _ _ _ "		
SIM		Off/On " _ _ _ _ "			
Sensor	Sensor 1 or 2	Type	Choose Type: pH, Cond, ORP.....		
		T COMP	Enter % Comp		
		ISO PT	Enter mV value		
	Qty of Sensors	Choose 1 sensor or 2 sensors			
	COMP	Dissociation, Interference, Percentage, OFF			
Load Default	Sensor/Transmitter	Yes/No			
DAMP	Enter Signal Dampening (# of readings to average, 0-100)				
<b>INFO</b> <b>(Information)</b>	XMTR	Configuration, Serial #, Name, Outputs			
	Sensor	Calibration logs, Serial #, Name			
<b>SIM</b> <b>(Simulate)</b>	System	Sensor 1 or 2	Fixed value Ramp		
		Relays	#1 ON/OFF		
	#2 ON/OFF				
	#3 ON/OFF				
	4-20 mA	4-20 mA Ch 1	Enter Value		
4-20 mA Ch 2		Enter Value			

Figure 3-1: LXT-380 Screen Map

Double tap any Selection/Adjustment key to enter the HOME Menu Screen. Five menu choices will appear, **CAL, CONFIG, INFO, SIM and HOLD**. Each of the Menus is detailed below.

### 3.2.1 HOLD (OUTPUT HOLD)

Actuating the HOLD Key activates the HOLD function, HOLD is ON, displayed.

- Freezes the 4-20 mA output at the last value prior to activation
- Freezes optional Alarm Relays in the current state
- While in the HOLD mode the % Output display toggles between the last value and HOLD



Actuating HOLD again turns the hold function off, Hold is OFF, displayed. The HOLD function remains ON until it is turned OFF. (See Time Out in CONFIG>XMTR>OUTPUT>HOLD).

### 3.2.2 CAL (CALIBRATION MENU)

Four options are available, **AUTO, STAND, MANUAL and TEMP**. On dual channel instruments choose Sensor 1 or Sensor 2 when prompted.

The first screen asks, “**Is this a New Sensor, YES / NO**”. If YES the calibration history from the previous sensor is cleared from memory and a new register is started, if NO then the calibration is written to the memory stack, three sets of data are stored.

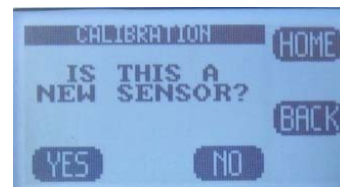

- **AUTO** is a two point calibration. The calibration proceeds in two steps, Auto Cal 1 is an offset calibration and Auto Cal 2 is a slope calibration. Auto Cal provides automatic solution recognition of the calibration solutions used for each measurement in accordance with the following list:
  1. pH Calibration Buffers (US Standard), pH 4.01, pH 7.00 and pH 10.00 (see Appendix A).



2. ORP Calibration Solutions: Quinhydrone saturated: pH 4.01= +89 mV, pH 7.00= +266 mV.
3. pION Calibration Solutions: 1.00, 10.00, 100.0 ppb, ppm, ppt (thousand).
4. Dissolved Oxygen: Zero ppm (Sodium sulfite, Na<sub>2</sub>SO<sub>3</sub> in water), Air saturated water, 8.25 ppm.

Any two solutions can be used for AUTO calibration however if solutions other than those listed above are used for calibration then the calibration values must be entered manually.



- **STAND** is standardization, a single point calibration. Standardizations are typically used to adjust the process reading to agree with a laboratory determined “grab sample” reading.
- **MANUAL** is a data entry screen. Manual calibration allows the user to enter a concentration with the corresponding mV value and a slope for an electrode. Laboratory generated calibration data for an electrode can be input to a remote analyzer where calibration is difficult or impractical.
- **TEMP** allows the displayed temperature to be trimmed to agree with actual process temperature.



### 3.2.3 CONFIG (CONFIGURATION MENU)

Four options are available in the Configure Menu, **XMTR**, **SENSOR**, **LOAD DEFAULT** and **Dampen**.

1. **XMTR** enters the Transmitter Configuration menu.

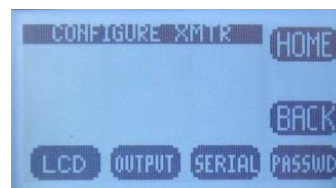
- **LCD** access the Display Configuration Menu.
- **SETUP** adjust screen lighting characteristics.
  - **Temp.** Choose °C or °F.
  - **CONT** adjust Contrast.
  - **BACK LIGHT** adjust Backlight Timeout, from always ON to OFF after 10 minutes.



- **GRAPH** provides the choice of which Graph style is displayed on the Home screen.
  - **LINE**, Moving average, vertical scale set to 0-100% of the 4-20 mA output and user defined time scale. 
  - **GAUGE**, Current reading 0-100% of 4-20 mA range.
  - **BAR**, Current reading 0-100% of 4-20 mA range.
- **LABELS**
  - **TAG**, Enter up to 2 lines x 16 characters, example, Name, tag #...  
Displayed in INFO screen 
  - **TAG ON**, Turn TAG ON/OFF, adds TAG to Main Display Sequence, DATA → mV → GRAF → TAG → DATA
  - **POP UP**, Turns ON/OFF, the double tap HOME Screen pop up memo
  - **SENSOR**, Enter up to 2 lines x 16 characters
- **OUTPUT** access the Output Configuration Menu
  - **4-20 mA** configure 4-20 mA output (PV or Temp or More) 
    - **RANGE** Enter 4 mA value and 20 mA value
    - **CAL** Trim 4.00 mA output and 20.00 mA output
    - **FAULT** Choose fault condition 3.5 mA, 22 mA, None

- **Optional** 2<sup>nd</sup> 4-20 mA, same as above
- **RELAY**

- **RLY1,2,3** Choose relay type:

- **Alarm**, enter the Set point ON, Set Point OFF, Expiration time, Delay ON and Delay OFF times and the State, **energize**: changes state from de-energized to energized on alarm.



- **Timed**, Enter Period, Duration times and Hold On/Off.
- **Fault**, No input required, relay condition changes from energize to deenergize.
- **Disable**, Inactivates relay and removes the relay button from the HOME screen display.

- **HOLD**, Freezes outputs at current value and locks relays in their current state.
  - **Hold Timeout**, Removes HOLD after a certain period of time, default setting: No Timeout, selections include 15 minutes, ½ hour, 1 hour.

- **SERIAL MODBUS** configure serial output

- **ADDRESS**, enter address: 001 to 247
- **BAUD**, Choose baud rate, default 9600
- **FORMAT**, set serial data format, default value: 8N1, 8 bit, no parity bit, 1 stop bit



- **SERIAL HART** configure output

- **ADDRESS**, enter address: 01-63
- **BAUD**, default 1200, no adjustment available
- **FORMAT**, default value: 8O1, 8 bit, Odd parity bit, 1 stop bit, no adjustment available.



- **PASSWD** Enter 4 character password to protect access to MENU Level, CAL Menu, CONFIG Menu and SIM Menu

(simulate). Each level can be turned ON or OFF and can have a unique password.



- **MENU ON/OFF**----- Locks Main Menu
- **CAL ON/OFF**-----Locks CAL and CONFIG
- **CONFIG ON/OFF**-----Locks CONFIG
- **SIM ON/OFF**-----Locks SIM and CONFIG

2. **SENSOR** enters the sensor configuration menu.

• **Choose SENSOR 1 or 2**

- **TYPE**, Allows LXT-380 transmitter to configure the SP3X sensor. For use only when switching the measurement electrode type in an SP3X sensor, i.e. for a pH electrode to a pION electrode. Select Sensor Type: pH, ORP, DO<sub>2</sub>, NH<sub>3</sub>, NH<sub>4</sub><sup>+</sup>, Br<sup>-</sup>, Ca<sup>++</sup>, Cl<sup>-</sup>, Conductivity, Resistivity, Cu<sup>++</sup>, CN<sup>-</sup>, F<sup>-</sup>, NO<sub>3</sub><sup>-</sup>, K<sup>+</sup>, Ag<sup>+</sup>, Na<sup>+</sup>, S<sup>-</sup>
- **T COMP**, Enter % temperature compensation per degree: pH, pION 0.33%, ORP 0.00%, DO<sub>2</sub> 4%, Conductivity 2%, Resistivity -5% (see Table Appendix E)
- **ISO PT**, Enter Iso Potential value in mV. The Iso Potential is the point where changes in the temperature do not cause changes to the signal.
- **COMP** Dual Channel Only, Sets compensation type: **Dissociation** (pKa), NH<sub>4</sub><sup>+</sup>, Free Chlorine, HF, S<sup>-2</sup>, **Interference**, X ppm Sensor 2 = 1 ppm Sensor 1, **Percentage** % change per pH.
- **Qty of SENSORS**, Choose 1 or 2



3. **Load Default** resets all Menus to factory default configuration.

### 3.2.4 INFO (INFORMATION MENU)

The Information Menu provides two choices:

1. **Transmitter Screen**, details the Name, Power type, Serial #, Firmware version and the output configuration(s).
2. **Sensor Screen**, details the Name, Part #, Serial # and three sets of Calibration data.

### 3.2.5 SIM (SIMULATION MENU)

The Simulation menu allows the Input or Output signals to be simulated.

- **SYSTEM** allows the input to be simulated. Two choices are available, **FIXED** is a fixed value, **RAMP** varies the signal across the 4-20 mA range, from the lowest value to the highest value and back, activating and deactivating relays if present. The **RAMP** has two adjustments the Ramp period, 30 seconds to 2 minutes and Duration; 1 cycle, 5, 10, 20, 30 minutes.
- **RELAYS** allows individual relays, #1, #2, and #3 to be activated and deactivated.
- **4-20 mA** allows the output to be simulated from 4.00 mA to 20.00 mA.

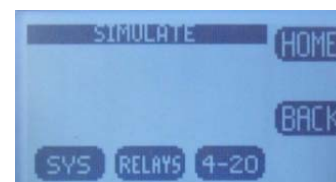
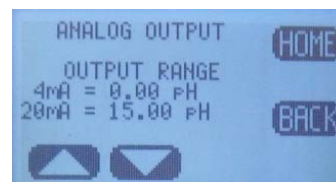

### 3.2.6 FAULT SCREENS

Fault	Definition	Recommendation
Memory Error	AN ERROR WAS FOUND WITH THE MEMORY OF THE MICROCONTROLLER	RETURN TO FACTORY FOR SERVICE
Input Voltage OOT	POWER IS OUT OF TOLERANCE	CHECK WIRING TO THE TRANSMITTER
+12V OOT	ONBOARD 12V IS OUT OF TOLERANCE	RETURN TO FACTORY FOR SERVICE
+3.3V OOT	ONBOARD 3.3V IS OUT OF TOLERANCE	RETURN TO FACTORY FOR SERVICE
Loss of Comm	COMMUNICATION WITH THE SENSOR WAS LOST	CHECK WIRING TO THE SENSOR
No Sensor	NO SENSOR WAS FOUND AT START-UP	CHECK WIRING TO THE SENSOR
Cal Failed	SENSOR CALIBRATION FAILED	1) CLEAN SENSING TIP 2) VERIFY SOLUTIONS 3) DO NOT LEAVE UNATTENDED 4) RE-CALIBRATE
Relay 1 Expired	RELAY 1 TIME ON EXPIRED	1) CHECK SENSOR OP 2) CHECK AUX EQUIP A) PUMPS B) TANKS
Relay 2 Expired	RELAY 2 TIME ON EXPIRED	1) CHECK SENSOR OP 2) CHECK AUX EQUIP A) PUMPS B) TANKS
Relay 3 Expired	RELAY 3 TIME ON EXPIRED	1) CHECK SENSOR OP 2) CHECK AUX EQUIP A) PUMPS B) TANKS

### 3.2.7 SENTINEL<sup>®</sup> SCREENS

The SENTINEL feature allows the Model LXT-380 transmitter to provide Pre-pHault diagnostic information about the accuracy of a pH, ORP or pION measurement. The SENTINEL displays a filled triangular gauge that decreases proportionally to the degradation of the reference electrode. A filled gauge indicates a properly functioning measurement while the emptying gauge indicates the remaining life of the electrode. This Pre-pHault diagnostic alerts the user to potential problems and provides a visual indicator of the sensor's remaining life before the measurement actually fails.

The Model LXT-380 transmitter only displays the SENTINEL functions when a Model SP3X SENTINEL sensor is connected. The Model SP3X SENTINEL sensor uses Diagnostic electrodes designated by Part #'s 20053XX, these electrodes use a triaxial connector with a,

PV connection (pH, ORP, Ion), Reference connection and Diagnostic connection.

On a dual channel instrument an asterisk \* will be displayed in the sensor name block, SENSOR 2 \*. The SENTINEL function will only be visible in the Single Screen mode, not in the Dual Screen mode. Toggle the BACK Key from Dual → Sensor 1 → Sensor 2 to see the SENTINEL function.

### Configure SENTINEL Function

The SENTINEL function is located in the Configure Sensor menu:

CONFIG → SENSOR → SENSOR 1 or 2 → MORE → SNTL

There are three values displayed:

$V_o$  = SENTINEL Voltage offset, The diagnostic voltage of a new electrode

$V_e$  = SENTINEL expiration Voltage,  $V_o$  + Range

RANGE = The shift in the diagnostic voltage required to trigger diagnostic fault.

The default values of  $V_o$  = 0.0 mV and the Range = 60 mV are good for most situations. The starting diagnostic voltage is typically near 0 mV on a new electrode and if the readings have drifted 60 mV apart (a full pH unit) then electrode service is required.



### 3.3 START UP GUIDE

Install and wire the LXT-380 Transmitter as described in Sections 2.1 and 2.2 above.

Connect the sensor to the transmitter as described in Section 2.2 above.

Supply power to the Model LXT-380 transmitter.

Verify the proper measurement type is displayed, pH, ORP or Ion. The sensor automatically uploads the measured parameter, the



calibration data and the range of measurement to the transmitter. The default configuration of the 4-20 mA output is the range of the sensor, 0-14 pH for pH sensors, -1500 - +1500 for ORP or 0-XXXX ppm for a pION Sensor. To change the 4-20 mA range, follow the instructions in Section 3.3.1 below.

### 3.3.1 CONFIGURE 4-20 MA OUTPUT RANGE

- Double press any key except the HOME key to enter the HOME Menu. Follow the path below to set the 4-20 mA range.
- HOME Menu → Press CONFIG → XMTR → OUTPUT → 4-20 (1)(2) → PV or TEMP.
- Press CHANGE to enter New Values.
- Choose 4 mA value, press OK.
- Enter value using ▲ or ▼ and NEXT to move to the next digit, press OK→Back.
- Choose 20 mA value, press OK.
- Enter value using ▲ or ▼ and NEXT to move to the next digit, press OK→Back.
- Press BACK to return to the CONFIGURE 4-20 mA screen or HOME to return to the HOME Menu screen.

### 3.3.2 CONFIGURE 4-20 MA FAULT CONDITION AND CAL

- In the CONFIGURE 4-20 mA screen, Press **MORE** → **FAULT** or
- Choose **Low Fault 3.5 mA** or **Hi Fault 22 mA** or **NONE**, (default setting **NONE**), Press OK.
- Press BACK → **CAL**, connect DVM to 4-20 mA line, Press 4.00 mA then adjust value to the DVM reading, Press 20.00 mA and adjust value to the DVM reading. The 4-20 mA output is calibrated. (PW=0000)

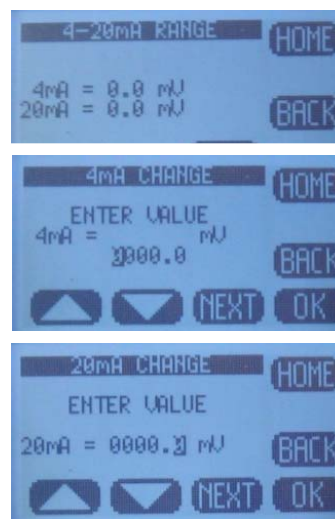



### 3.3.3 CONFIGURE ALARM RELAYS (RELAYS OPTIONAL)

- HOME Menu → Press CONFIG → XMTR → OUTPUT → RELAYS→RLY1
- Choose the **ALARM**, **TIMER**, **FAULT** or **DISABLE** mode for Relay 1.
- **ALARM** Displays:
  - **SET POINT ON:** The Process Variable Value that activates the relay.
  - **EXPIRATION:** Enter a time that should not be exceeded before the PV should have changed enough to activate the OFF set point. At the Expiration time the relay is deactivated and a Fault condition is initiated. Fault: Relay 1 Time expired: Cause: Loss of reagent, failed sensor ....
  - **Delay ON:** The amount of time the PV must remain above/below the set point before the relay activates.
  - **SET POINT OFF:** The Value of the process variable that deactivates the relay.
    - SET POINT OFF > Set Point → Low Set Point
    - SET POINT OFF < Set Point → Hi Set Point
  - **Delay OFF:** The amount of time the PV must remain above/below the hysteresis point before the relay deactivates.
  - **STATE: Energize** (relay is energized on activation) NO relay closes on activation/**De-energize** (The energized relay is de-energized on activation) NO relay opens on activation.
- **TIMER** activates the relay periodically for a specific duration, user configured period and duration.
- **FAULT** sets the relay condition to a de-energize state and a NO relay opens and a NC relay closes in response to a Fault condition.



- **DISABLE** turns off the relay and removes it's icon from the HOME screen.

### Setting up an Alarm Relay

- Choose **ALARM**
- Press **CHANGE** to enter new values
- Choose ON Set Point, Press OK.
- Enter value using ▲ or ▼ and NEXT to move to the next digit, press OK, press BACK (Min – Max values indicate the range of acceptable values)
- Choose Expiration, Press OK.
- Choose time from drop down menu using ▲ or ▼, press OK, press BACK.
- Choose Delay ON, Press OK.
- Enter value using ▲ or ▼ and NEXT to move to the next digit, press OK, press BACK.
- Choose OFF Set Point, Press OK.
- Enter value using ▲ or ▼ and NEXT to move to the next digit, press OK, press BACK.
- Choose Delay OFF, Press OK.
- Enter value using ▲ or ▼ and NEXT to move to the next digit, press OK, and press BACK when done to exit Relay 1.
- Repeat for Relay 2 and Relay 3.



### 3.3.4 EXIT MENUS AND RETURN TO MAIN DISPLAY

- Press HOME Key to return to the Home Menu Screen.
- Press Hold to turn OFF Hold.
- Press EXIT Key to exit the menu.



- “Save Changes?” press YES.
- Choose Display Mode, **DATA**, **mV** or **GRAF** by pressing selection Key. The selection key displays which screen will be displayed next.
  - The type of graphical display used, Line, Bar or Gauge is selected in CONFIG → XMTR → LCD → GRAPH → LINE, GAUGE, BAR.

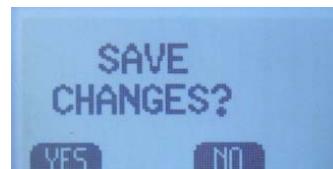

### 3.3.5 SENSOR START UP

All sensors are supplied with protective caps over the sensing end. Remove the cap(s) from the sensor before installing in the process. All sensors were calibrated at the factory before shipment, no calibration should be necessary before use.

Allow the sensor to equilibrate to the process solution conditions for ½ hour before verifying the reading against a grab sample. If calibration is required follow the instruction in Section 4.0 below.

## 3.4 USER SELECTABLE OPTIONS

### 3.4.1 SCREEN LIGHTING

LED back lighting is available on DC powered instruments only and this feature is inactive on all loop powered instruments.

Contrast can be adjusted for optimal viewing. The Backlight can be adjusted to timeout after a set period of time or remain on.

**Location:** CONFIG → XMTR → LCD → Set Up → CONT, BACK LIGHT.

### 3.4.2 GRAPHICAL DISPLAY

There are three graphical display choices:

- **LINE**, The Line graph is a moving average of the process variable with the 4-20 mA range as the maximum/minimum values and a choice of time scales.

The Time scale is the amount of time displayed across the full screen. Choices include:

Full Screen Period	15 min.	1 hour	12 hr.	1 day	2 days
Sample Rate ( 1 point every)	10 sec.	40 sec.	8 min.	15 min.	30 min.

- **GAUGE**, Live reading displaying 0-100% of 4-20 mA range. The Alarm Relay number(s), #1, #2 and #3 mark the respective set points on graph.
- **BAR**, Live reading displaying 0-100% of 4-20 mA range. The Alarm Relay number(s), #1, #2 and #3 mark the respective set points on graph.

Pressing OK after selecting a Graphical Display will exit the menu structure and return to the Main Display.

**Location:** CONFIG → XMTR → LCD → GRAPH.

### **3.4.3 TAG TRANSMITTER NAME**

Two 16 character lines are available for naming the transmitter, Upper and Lower case characters, Numbers and Punctuation are available. The information entered will be displayed in the INFO screen and optionally in the Main display sequence if activated in the TAG ON menu. The character set is listed below sequentially; the first character in the set is an empty space.

! ” # \$ % & ‘ ( ) \* + , - . / 0 1 2 3 4 5 6 7 8 9 : ; < = > ? @ A B C D E F  
 G H I J K L M N O P Q R S T U V W X Y Z [ ¥ ] ^ \_  
 ‘ a b c d e f g h I j k l m n o p q r s t u v w x y z { | } → ←

Entry is accomplished by scrolling through the alphanumeric list with the ▲ (forward →) and ▼ (backwards ←) arrows to the character of choice and then pressing **NEXT** to advance the cursor to the next digit. Pressing and holding the ▲ or ▼ keys will initiate two speed auto scrolling. Press **BACK** to exit the screen.

**Location:** CONFIG → XMTR → LCD → LABELS → TAG



### 3.4.4 SENSOR NAME

Two 16 character lines are available for naming the Sensor, Upper and Lower case characters, Numbers and Punctuation are available. The information entered will be displayed in the INFO screen. Entry is accomplished by scrolling through the alphanumeric list with the ▲ (forward →) and ▼ (backwards ←) arrows to the character of choice and then pressing **NEXT** to advance the cursor to the next digit. Pressing and holding the ▲ or ▼ keys will initiate two speed auto scrolling. Press **BACK** to exit the screen.

**Location:** CONFIG → XMTR → LCD → LABELS → SENSOR

### 3.4.5 PASSWORD PROTECTION

**PASSWD** Enter a 4 character password to protect access to MENU Level, CAL Menu, CONFIG Menu and SIM Menu (simulate). Each level can be turned ON or OFF and can have a unique password. Upper Case Characters and Numbers are available for use.

Place the cursor in front of the level to be changed and Press **OK**. Move the cursor to **ON** and press **OK** to change the password status from OFF to ON.

Entry is accomplished by scrolling through the alphanumeric list with the ▲ (forward →) and ▼ (backwards ←) arrows to the character of choice and then pressing **NEXT** to advance the cursor to the next digit. Pressing and holding the ▲ or ▼ keys will initiate two speed auto scrolling.

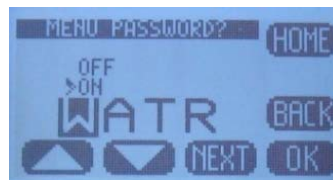

- **MENU ON/OFF:** Locks Main Menu
- **CAL ON/OFF :** Locks CAL and CONFIG
- **CONFIG ON/OFF:** Locks CONFIG
- **SIM ON/OFF:** Locks SIM and CONFIG

In the case of a **Lost or Forgotten password** enter **MSTR** to access the screen.

**Location:** CONFIG → XMTR → PSSWD

**Blank Page**

## 4.0 CALIBRATION

The Model LXT-380 transmitter provides three methods of calibration:

1. Auto Calibration
2. Standardize Calibration
3. Manual Calibration



### 4.0.1 AUTO CALIBRATION DESCRIPTION

Auto calibration is the primary calibration method for all measurements. AUTO calibration automatically recognizes the calibration solution the sensor is in and proposes the actual temperature compensated value for acceptance. AUTO calibration can be a single point or two point calibration. A single point calibration sets the zero point or offset value of the sensor. The second calibration sets the slope or span of the sensor.

When the AUTO key is pressed the transmitter displays the PV (Process Variable) and the associated mV signal from the sensor. When the reading has stabilized a calibration value is AUTOMATICALLY proposed, i.e. 7.00 pH, 10 ppm Fluoride ion, 0.00 mg/L Dissolved Oxygen.

**The user is prompted to accept the proposed calibration value or enter and accept another value.** Once Cal 1 is accepted the user is asked to continue to Cal 2, yes/no. If yes, then a second calibration value is proposed when the sensor has stabilized in the second calibration solution. Accept the value and the calibration is complete.

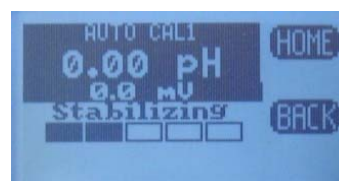

At the end of each calibration the Offset and Slope are displayed in the respective units, pH, mV, ppm, mg/l.



#### 4.0.2 STANDARDIZE CALIBRATION DESCRIPTION

A Standardize Calibration is a single point calibration where the transmitter's reading is adjusted to agree with a solution of known value, either a calibration standard, a grab sample or laboratory determined value. In many cases the constituents and the pressure and temperature of the process solution are very different from the calibration solution. In these cases, once the sensor has equilibrated, the Zero Point or Offset value may have shifted from the original calibration point. Standardization allows for correction of this type of offset.

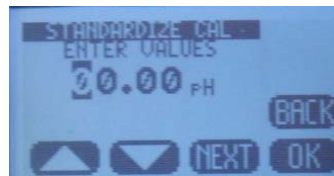

When the STAND key is pressed, the user is prompted to ENTER VALUE. The user enters the value they want the transmitter to read and press OK. The user is then prompted to accept the value, yes/no, and the calibration is complete. Standardizations are single point calibrations.

At the end of each calibration the Offset and Slope are displayed in the respective units, pH, mV, ppm, mg/l.

#### 4.0.3 MANUAL CALIBRATION DESCRIPTION

Manual calibration allows the user to enter calibration data for an electrode into the transmitter without performing a calibration. A MANUAL Calibration requires the entry of three pieces of data, (1) A concentration with the (2) corresponding mV value and (3) a slope for the electrode. This allows laboratory generated calibration data for an electrode to be entered in a remote analyzer where calibration is difficult or impractical.

Example: MANUAL Calibration for a pH electrode:

1. Calibrate the pH electrode in the laboratory.
2. Record the mV value of some pH Standard, pH 7.00 buffer = 6.8 mV (any pH – mV pair will work).
3. Calculate and Record the slope of the electrode, 58.2 mV/pH.
4. Install the electrode into the field mounted

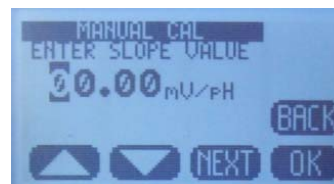
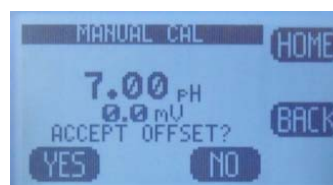

sensor.

5. Press **MANUAL** and enter the pH value, 7.00 pH, press **mV** and enter the corresponding mV value, 6.8 mV, press **OK**, Accept Offset?, press **YES**, enter slope 58.2 mV/pH, press **OK**, Accept Slope?, Press **YES**.

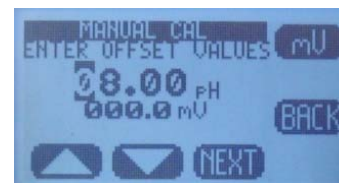

6. The Calibration is complete, the Offset and Slope values are displayed, press **OK** to exit.

## 4.1 pH CALIBRATION PROCEDURES

AUTO Calibration recognizes pH 4.01, pH 7.00 and pH 10.00 buffer solutions for automatic, temperature compensated calibrations. Any calibration solutions can be used but the pH value will have to be entered manually. Follow the steps below to accomplish a pH calibration. Example uses pH 7.00 and pH 4.01 buffers.

### 4.1.1 AUTO CAL USING pH 4.01, 7.00, 10.00 BUFFERS

Action	Prompt
Double Press any Button	MENU HOME, Hold is OFF
Press <b>HOLD</b>	Hold freezes 4-20 mA Output and locks Alarm Relays during Calibration
Press <b>CAL</b>	Is this a new Sensor? (Yes erases CAL Log in INFO, NO adds CAL to existing Log)
Press Yes/ <b>NO</b>	Place Sensor in CAL Solution ( use pH 7.00 buffer)
Press <b>AUTO</b> then <b>CAL 1</b>	STABILIZING, 7.00 pH x.x mV, 7.00 pH corrected Accept Cal 1?
Press <b>YES</b>	CAL1 Value 7.00 pH, Continue to CAL2? Move sensor to 4.01 pH buffer solution
Press <b>YES</b>	STABILIZING, 4.00 pH xxx.x mV, 4.00 pH corrected Accept Cal?
Press <b>YES</b>	OFFSET: 7.00 pH x.x mV, SLOPE: 59.16 mV/pH (data written to Log)
Press <b>OK</b>	Calibration complete
Press <b>HOME</b>	Hold is ON
Press <b>HOLD</b>	Turn off Hold
Press <b>EXIT</b>	Main Display

### 4.1.2 AUTO CAL USING OTHER PH BUFFERS

Action	Prompt
Double Press any Button	MENU HOME, Hold is OFF
Press <b>HOLD</b>	Hold freezes 4-20 mA Output and locks Alarm Relays during Calibration
Press <b>CAL</b>	Is this a new Sensor? (Yes erases CAL Log in INFO, NO adds CAL to existing Log)
Press <b>YES/NO</b>	Place Sensor in CAL Solution
Press <b>AUTO then CAL 1</b>	STABILIZING, xx.xx pH x.x mV, 7.00 pH corrected Accept Cal?
Press <b>NO</b>	Enter CAL 1 Value
Press <b>▲ ▼ NEXT</b>	xx.xx pH (use arrows and NEXT to enter pH Buffer value)
Press <b>OK</b>	xx.xx pH, xxx.x mV, Accept this Value
Press <b>YES</b>	CAL 1 Value xx.xx pH, Continue to CAL 2? (Place Sensor in 2 <sup>nd</sup> calibration buffer)
Press <b>YES</b>	STABILIZING, xx.xx pH xxx.x mV, 4.00 pH corrected Accept Cal?
Press <b>NO</b>	Enter CAL 2 Value
Press <b>▲ ▼ NEXT</b>	xx.xx pH (use arrows and NEXT to enter pH Buffer value)
Press <b>OK</b>	xx.xx pH, xxx.x mV, Accept this Value
Press <b>YES</b>	OFFSET: xx.xx pH x.x mV, SLOPE: 59.16 mV/pH (data written to Log)
Press <b>OK</b>	Calibration complete
Press <b>HOME</b>	Hold is ON
Press <b>HOLD</b>	Turn off Hold
Press <b>EXIT</b>	Main Display

### 4.1.3 STANDARDIZE

Leave the sensor in the process solution, take a grab sample from the process and determine the pH or place sensor in a calibration standard solution.

Action	Prompt
Double Press any Button	MENU HOME, Hold is OFF
Press <b>HOLD</b>	Hold freezes 4-20 mA Output and locks Alarm Relays during Calibration
Press <b>CAL</b>	Is this a new Sensor? (Yes, erases CAL Log in INFO, NO adds CAL to existing Log)
Press <b>NO</b>	Place Sensor in CAL Solution (or leave in the process solution)
Press <b>STAND</b>	Enter Value
Press <b>▲ ▼ NEXT</b>	xx.xx pH (use arrows and NEXT to enter process pH value)
Press <b>OK</b>	xx.xx pH, xxx.x mV, Accept Value?
Press <b>YES</b>	OFFSET: xx.xx pH x.x mV, SLOPE: xx.xx mV/pH (this data written to Log)
Press <b>OK</b>	Back to Cal Menu
Press <b>HOME</b>	Hold is ON (Press HOLD to turn off Hold)
Press <b>HOLD</b>	Turn off Hold
Press <b>EXIT</b>	Main Display

## 4.2 ORP CALIBRATION PROCEDURES

AUTO Calibration recognizes Quinhydrone solutions (mV<sub>a</sub>), pH 7.00 quinhydrone solution (90 mV) and pH 4.01 quinhydrone solution (267 mV) for automatic ORP calibrations. Any calibration solutions can be used but the ORP value will have to be entered manually. Follow the steps below to accomplish an ORP calibration.

### 4.2.1 AUTO CAL WITH QUINHYDRONE

Action	Prompt
Double Press any Button	MENU HOME, Hold is OFF
Press HOLD	Hold freezes 4-20 mA Output and locks Alarm Relays during Calibration
Press CAL	Is this a new Sensor? (Yes erases CAL Log in INFO, NO adds CAL to existing Log)
Press Yes/NO	Place Sensor in CAL Solution ( use pH 7.00 Q solution)
Press AUTO then CAL 1	STABILIZING, xxx.x mV, xxx.x mV <sub>a</sub> , 90.0 mV corrected Accept Cal?
Press YES	CAL1 Value 90.0 mV, Continue to CAL2? Move sensor to pH 4.01 Q solution
Press YES	STABILIZING, 269.2 mV 267.0 mV <sub>a</sub> , 267 mV corrected Accept Cal?
Press YES	OFFSET: 90.0 mV <sub>a</sub> , 87 mV, SLOPE: 1.02 mV/ mV <sub>a</sub> (data written to Log)
Press OK	Calibration complete
Press HOME	Hold is ON
Press HOLD	Turn off Hold
Press EXIT	Main Display

### 4.2.2 STANDARDIZE

Leave the sensor in the process solution, take a grab sample from the process and determine the ORP.

Action	Prompt
Double Press any Button	MENU HOME, Hold is OFF
Press HOLD	Hold freezes 4-20 mA Output and locks Alarm Relays during Calibration
Press CAL	Is this a new Sensor? (Yes, erases CAL Log in INFO, NO adds CAL to existing Log)
Press NO	Place Sensor in CAL Solution (or leave in the process solution)
Press STAND	Enter Value
Press ▲ ▼ NEXT	xx.xx mV (use arrows and NEXT to enter process ORP value)
Press OK	xxx.x mV, xxx.x mV, Accept Value?
Press YES	OFFSET: xxx.x mV xxx.x mV, SLOPE: xx.xx mV/mV (this data written to Log)
Press OK	Back to Cal Menu
Press HOME	Hold is ON (Press HOLD to turn off Hold)
Press HOLD	Turn off Hold
Press EXIT	Main Display

### 4.3 PION CALIBRATION PROCEDURES

AUTO Calibration recognizes 1, 10 or 100 ppm/ppb calibration solutions. Any calibration solutions can be used but the ppm value will have to be entered manually. Follow the steps below to accomplish a pION calibration.

#### 4.3.1 AUTO CAL USING 1, 10, 100 PPM SOLUTIONS

Action	Prompt
Double Press any Button	MENU HOME, Hold is OFF
Press <b>HOLD</b>	Hold freezes 4-20 mA Output and locks Alarm Relays during Calibration
Press <b>CAL</b>	Is this a new Sensor? (Yes erases CAL Log in INFO, NO adds CAL to existing Log)
Press <b>Yes/NO</b>	Place Sensor in CAL Solution ( use 10 ppm solution)
Press <b>AUTO then CAL 1</b>	STABILIZING, 10.00 ppm, xxx.x mV, 10.00 ppm corrected, Accept Cal?
Press <b>YES/NO</b>	CAL1 Value 10.00 ppm, Continue to CAL2? Move sensor to 100 ppm solution
Press <b>YES</b>	STABILIZING, 100.0 ppm, xx.xx mV, 100 ppm corrected, Accept Cal?
Press <b>YES</b>	OFFSET: 10.00 ppm, 310 mV, SLOPE: 55.1 mV/ decade (data written to Log)
Press <b>OK</b>	Calibration complete
Press <b>HOME</b>	Hold is ON
Press <b>HOLD</b>	Turn off Hold
Press <b>EXIT</b>	Main Display

#### 4.3.2 AUTO CAL USING NON-DECIMAL PPM SOLUTIONS

Action	Prompt
Double Press any Button	MENU HOME, Hold is OFF
Press <b>HOLD</b>	Hold freezes 4-20 mA Output and locks Alarm Relays during Calibration
Press <b>CAL</b>	Is this a new Sensor? (Yes erases CAL Log in INFO, NO adds CAL to existing Log)
Press <b>YES/NO</b>	Place Sensor in CAL Solution
Press <b>AUTO then CAL 1</b>	STABILIZING, xx.xx pH x.x mV, 10.00 ppm corrected Accept Cal?
Press <b>NO</b>	Enter CAL 1 Value
Press <b>▲ ▼ NEXT</b>	xxxx.x ppm (use arrows and NEXT keys to enter Cal value)
Press <b>OK</b>	xxxx.x ppm, xxx.x mV, Accept this Value
Press <b>YES</b>	CAL 1 Value xxxx.x ppm, Continue to CAL 2? (Place Sensor in 2 <sup>nd</sup> calibration solution)
Press <b>YES</b>	STABILIZING, xxxx.x ppm xxx.x mV, xxx.x ppm corrected Accept Cal 2?
Press <b>NO</b>	Enter CAL 2 Value
Press <b>▲ ▼ NEXT</b>	xxxx.x ppm (use arrows and NEXT keys to enter Cal value)
Press <b>OK</b>	xxxx.x ppm, xxx.x mV, xxx.x ppm corrected Accept Cal 2?
Press <b>YES</b>	OFFSET: xxxx.x ppm xxx.x mV, SLOPE: 55.40mV/decade (data written to Log)
Press <b>OK</b>	Calibration complete
Press <b>HOME</b>	Hold is ON
Press <b>HOLD</b>	Turn off Hold
Press <b>EXIT</b>	Main Display

### 4.3.3 STANDARDIZE

Leave the sensor in the process solution, take a grab sample from the process and determine the Ion concentration.

Action	Prompt
Double Press any Button	MENU HOME, Hold is OFF
Press HOLD	Hold freezes 4-20 mA Output and locks Alarm Relays during Calibration
Press CAL	Is this a new Sensor? (Yes, erases CAL Log in INFO, NO adds CAL to existing Log)
Press NO	Place Sensor in CAL Solution (or leave in the process solution)
Press STAND	Enter Value
Press ▲ ▼ NEXT	xxxx.x ppm (use arrows and NEXT to enter process Ion ppm value)
Press OK	xxxx.x ppm, xxx.x mV, Accept Value?
Press YES	OFFSET: xxxx.x ppm xxx.x mV, SLOPE: xx.xx mV/DEC (this data written to Log)
Press OK	Back to Cal Menu
Press HOME	Hold is ON (Press HOLD to turn off Hold)
Press HOLD	Turn off Hold
Press EXIT	Main Display

## 4.4 SP3X DISSOLVED OXYGEN CALIBRATION PROCEDURES

The dissolved oxygen AUTO Cal acknowledges zero ppm, mg/l, % SAT for CAL 1 and the temperature compensated value for atmospheric oxygen, 8.25 ppm, mg/l at 25°C or 100 % SAT for CAL 2.

The zero point is set by placing the sensor into an oxygen free solution and verifying the displayed value drops to a value below 1 mV. The sensor will take a few minutes to equilibrate to the zero oxygen solution but for the highest accuracy it is best to wait 15-20 minutes before initiating a calibration. The typical sensor will burn down to 0.5 – 0.7 mV in an hour or so in a zero ppm solution. A zero ppm O<sub>2</sub> solution can be made by adding approximately 5 grams of sodium sulfite to a liter of distilled water or purging the sample with nitrogen gas.

The slope (CAL 2) is set by placing the sensor in air saturated distilled water or water saturated (100% humidity) air. The easiest method is to suspend the sensor vertically in beaker with a ½” of water in the bottom slightly above the water.

A STANDardize calibration adjusts the CAL 2 value, resetting the slope of the sensor, mV/ppm.

The actual concentration in mg/L (C) is equal to the Saturation value at the given temperature multiplied by the altitude and air pressure corrections. Determine the calibration temperature and look up the saturation value (S) in Table 1 below. Then determine the altitude correction (K) from Table 2 and the current air pressure in bar (P), 1 bar equals 14.7 psi. Use 1 bar if the actual air pressure is unknown.

$$C = S \times K \times P$$

**Example:**

Temperature = 20°C → Saturation = 9.08 mg/L, Altitude = 1200 Ft. → K = 0.960, Air Pressure 1.014 bar:

$$C = 9.08 \times 0.960 \times 1.014 = 8.84 \text{ mg/L}$$

The LXT-380 transmitter uses the temperature compensated Saturation Index for AUTO Cal, however the user can enter the altitude and pressure compensated value of 8.84 ppm as the calibration value when prompted to “Accept Value?” in CAL 2.

*Table 1 Saturation Index*

Temperature °C (°F)	Saturation mg/L	Temperature °C (°F)	Saturation mg/L	Temperature °C (°F)	Saturation mg/L
<b>0 (32)</b>	14.64	<b>14 (57)</b>	10.28	<b>28 (82)</b>	7.82
<b>1 (34)</b>	14.23	<b>15 (59)</b>	10.06	<b>29 (84)</b>	7.69
<b>2 (36)</b>	13.83	<b>16 (61)</b>	9.85	<b>30 (86)</b>	7.55
<b>3 (38)</b>	13.45	<b>17 (63)</b>	9.64	<b>31 (88)</b>	7.42
<b>4 (39)</b>	13.09	<b>18 (64)</b>	9.45	<b>32 (90)</b>	7.30
<b>5 (41)</b>	12.75	<b>19 (66)</b>	9.26	<b>33 (91)</b>	7.18
<b>6 (43)</b>	12.42	<b>20 (68)</b>	9.08	<b>34 (93)</b>	7.06
<b>7 (45)</b>	12.11	<b>21 (70)</b>	8.90	<b>35 (95)</b>	6.94
<b>8 (46)</b>	11.81	<b>22 (72)</b>	8.73	<b>36 (97)</b>	6.83
<b>9 (48)</b>	11.53	<b>23 (73)</b>	8.57	<b>37 (99)</b>	6.72
<b>10 (50)</b>	11.25	<b>24 (75)</b>	8.41	<b>38 (100)</b>	6.61
<b>11 (52)</b>	10.99	<b>25 (77)</b>	8.25	<b>39 (102)</b>	6.51
<b>12 (54)</b>	10.75	<b>26 (79)</b>	8.11	<b>40 (104)</b>	6.41
<b>13 (55)</b>	10.51	<b>27 (81)</b>	7.96		

Table 2 Altitude Correction

Altitude m (Ft.)	K	Altitude m (Ft.)	K	Altitude m (Ft.)	K
Sea Level 0	1.000	700 (2300)	0.922	1400 (4600)	0.849
50 (160)	0.994	750 (2450)	0.916	1450 (4750)	0.844
100 (330)	0.988	800 (2600)	0.911	1500 (4900)	0.839
150 (500)	0.982	850 (2800)	0.905	1550 (5100)	0.834
200 (660)	0.977	900 (2950)	0.900	1600 (5250)	0.830
250 (820)	0.971	950 (3100)	0.895	1650 (5400)	0.825
300 (980)	0.966	1000 (3300)	0.890	1700 (5600)	0.820
350 (1200)	0.960	1050 (3450)	0.885	1750 (5750)	0.815
400 (1300)	0.954	1100 (3600)	0.879	1800 (5900)	0.810
450 (1500)	0.949	1150 (3775)	0.874	1850 (6050)	0.805
500 (1650)	0.943	1200 (3950)	0.869	1900 (6200)	0.801
550 (1800)	0.938	1250 (4100)	0.864	1950 (6375)	0.796
600 (2000)	0.932	1300 (4250)	0.859	2000 (6550)	0.792
650 (2150)	0.927	1350 (4400)	0.854		

## 4.5 CONDUCTIVITY SENSORS

AUTO Calibration recognizes air for zero point (Cal 1) and 50 $\mu$ S, 100 $\mu$ S, 500 $\mu$ S, 1mS, 5mS, 10mS, 50mS and 100mS solutions for the span (Cal 2). Any calibration solutions can be used but the conductivity value will have to be entered manually. Use a calibration standard near the conductivity of the process solution. Example uses air and 1mS.

### 4.5.1 AUTO CAL USING AIR AND CONDUCTIVITY STANDARD

Action	Prompt
Double Press any Button	MENU HOME, Hold is OFF
Press <b>HOLD</b>	Hold freezes 4-20 mA Output and locks Alarm Relays during Calibration
Press <b>CAL</b>	Is this a new Sensor? (Yes erases CAL Log in INFO, NO adds CAL to existing Log)
Press <b>Yes/NO</b>	Remove the Sensor from Solution and dry the front end, Air = 0.00 $\mu$ S
<b>To perform zero CAL press CAL 1, to skip zero cal press CAL 2, only if a zero cal was previously done on the sensor</b>	
Press <b>AUTO</b> then <b>CAL 1</b>	STABILIZING, 0.00 $\mu$ S, 1.17 V, 0.00 $\mu$ S corrected, Accept Cal?
Press <b>YES</b>	CAL 1 Value 0.00 $\mu$ S, Continue to CAL2? Move sensor to 1.00 mS solution



Press YES	STABILIZING, 1.00 mS, 98X.X mV, 1.000 $\mu$ S corrected, Accept Cal?
Press YES	OFFSET: 0.00 ppm, 174.4 mV, SLOPE: 984 (data written to Log)
Press OK	Calibration complete
Press HOME	Hold is ON
Press HOLD	Turn off Hold
Press EXIT	Main Display

#### 4.5.2 STANDARDIZE

With the sensor in the process solution, take a grab sample from the process and determine the conductivity using a qualified laboratory conductivity meter.

Action	Prompt
Double Press any Button	MENU HOME, Hold is OFF
Press HOLD	Hold freezes 4-20 mA Output and locks Alarm Relays during Calibration
Press CAL	Is this a new Sensor? (Yes, erases CAL Log in INFO, NO adds CAL to existing Log)
Press NO	With the sensor in the process solution
Press STAND	Enter the laboratory determined conductivity value
Press ▲ ▼ NEXT	xxx.xx $\mu$ S/mS (use arrows and NEXT to enter process value)
Press OK	xxx.xx $\mu$ S/mS, xxx.x mV, Accept Value?
Press YES	OFFSET: 0.00 $\mu$ S 1.0 mV, SLOPE: xx.xx mV/ppm (this data written to Log)
Press OK	Back to Cal Menu
Press HOME	Hold is ON (Press HOLD to turn off Hold)
Press HOLD	Turn off Hold
Press EXIT	Main Display

## 4.6 TDS CONDUCTIVITY SENSORS

The Total Dissolved Solids measurement (TDS) on the Model LXT-380 transmitter is made with an SP3X conductivity sensor and a correlation factor. (*Conductivity in  $\mu$ S x correlation factor = ppm*).

Conductivity is a measurement of a solution's electrolytic conductivity, 1/ohms. The type of dissolved ions in the solution is irrelevant to the measurement. TDS is a measurement of concentration, ppm (mg/L). Since different salts contribute different amounts of conductivity to a solution, TDS measurements are only valid between solutions of the same chemical makeup. As an example, 1000 ppm of TDS in natural waters has a conductivity around 1400  $\mu$ S (correlation factor 0.6712), 1000 ppm of KCl has a conductivity around 2000  $\mu$ S (correlation factor 0.5000) and 1000 ppm of NaOH has a conductivity

around 6000  $\mu\text{S}$  (correlation factor 0.1667). All three solutions have a TDS of 1000 ppm but the conductivities are 1400  $\mu\text{S}$ , 2000  $\mu\text{S}$  and 6000  $\mu\text{S}$ . A TDS measurement is only valid for a solution with the same chemical make up as the solution used for calibration.

Calibration is accomplished in two steps; Step 1 Conductivity AUTO Calibration of the sensor (see section 4.7.1 above) and then Step 2 correlation of conductivity to the TDS. The second step can be done by entering the correlation factor into the CONFIG  $\rightarrow$  SENSOR  $\rightarrow$  TDS menu or by standardizing the sensor in a solution of known TDS in the CAL  $\rightarrow$  STAND menu by entering the TDS value. Since the correlation of conductivity to concentration is not linear it is best to calibrate the sensor near the measured value.

#### 4.6.1 STANDARDIZE

With the sensor in the process solution, take a grab sample from the process and determine the TDS using a qualified laboratory method.

Action	Prompt
Double Press any Button	MENU HOME, Hold is OFF
Press <b>HOLD</b>	Hold freezes 4-20 mA Output and locks Alarm Relays during Calibration
Press <b>CAL</b>	Is this a new Sensor? (Yes, erases CAL Log in INFO, NO adds CAL to existing Log)
Press <b>NO</b>	With the sensor in the process solution or calibration standard
Press <b>STAND</b>	Enter the laboratory determined TDS value
Press <b>▲ ▼ NEXT</b>	xxx.xx ppm (use arrows and NEXT to enter process value)
Press <b>OK</b>	xxx.xx ppm, xxx.x mV, Accept Value?
Press <b>YES</b>	Current value: xx.xx ppm, Desired value: xx.xx ppm, Offset: xx.xx ppm
Press <b>OK</b>	Back to Cal Menu
Press <b>HOME</b>	Hold is ON (Press HOLD to turn off Hold)
Press <b>HOLD</b>	Turn off Hold
Press <b>EXIT</b>	Main Display

## 4.7 RESISTIVITY SENSORS

AUTO Calibration recognizes Air for zero point (Cal 1) and a Meg-Ohm process solution for the span (Cal 2). Use the actual process solution or a solution near the resistivity of the process solution. The example below uses air and 15 M $\Omega$ . The Cal 1, air calibration value is very stable and need not be done for every calibration.

### 4.7.1 AUTO CAL USING AIR AND MEG-OHM PROCESS WATER

Action	Prompt
Double Press any Button	MENU HOME, Hold is OFF
Press <b>HOLD</b>	Hold freezes 4-20 mA Output and locks Alarm Relays during Calibration
Press <b>CAL</b>	Is this a new Sensor? (Yes erases CAL Log in INFO, NO adds CAL to existing Log)
Press <b>Yes/NO</b>	Remove the Sensor from Solution and dry the front end
<b>To perform zero CAL press CAL 1, to skip zero cal press CAL 2, only if a zero cal was previously done on the sensor</b>	
Press <b>AUTO</b> then <b>CAL 1</b>	STABILIZING, 55.000 MΩ, 1.20 V, 55.000 MΩ corrected, Accept Cal?
Press <b>YES</b>	CAL 1 Value 55.000 MΩ, Continue to CAL2? Move sensor to MΩ solution
Press <b>YES</b>	STABILIZING, 9.875 MΩ, 517 mV, 9.875 MΩ corrected, Accept Cal?
Press <b>NO</b>	Enter actual MΩ value of the solution, Accept Cal
Press <b>YES</b>	OFFSET: 55.000 MΩ, 1.20 V , SLOPE: 0.938 (data written to Log)
Press <b>OK</b>	Calibration complete
Press <b>HOME</b>	Hold is ON
Press <b>HOLD</b>	Turn off Hold
Press <b>EXIT</b>	Main Display

### 4.7.2 STANDARDIZE

With the sensor in the process solution, take a grab sample from the process and determine the conductivity using a qualified laboratory conductivity meter.

Action	Prompt
Double Press any Button	MENU HOME, Hold is OFF
Press <b>HOLD</b>	Hold freezes 4-20 mA Output and locks Alarm Relays during Calibration
Press <b>CAL</b>	Is this a new Sensor? (Yes, erases CAL Log in INFO, NO adds CAL to existing Log)
Press <b>NO</b>	With the sensor in the process solution
Press <b>STAND</b>	Enter the laboratory determined conductivity value
Press <b>▲ ▼ NEXT</b>	xxx.xx MΩ (use arrows and NEXT to enter process value)
Press <b>OK</b>	Current Value xx.xx MΩ, Desired Value: xx.xx MΩ, Offset XX.XX OK?
Press <b>OK</b>	Back to Cal Menu
Press <b>Home</b>	Hold is ON (Press HOLD to turn off Hold)
Press <b>HOLD</b>	Turn off Hold
Press <b>EXIT</b>	Main Display

## 5.0 MAINTENANCE

---

No periodic maintenance is required for the Teledyne Model LXT-380 Transmitter.

Do not open the LXT-380 enclosure in a hazardous environment without ensuring that NO hazardous gases, vapor or dust is present. Remove power prior to opening cover and/or performing any service, repair or cleaning.

When you open the front cover and/or cable glands, make sure that the seals are clean and correctly fitted when the unit is re-assembled in order to maintain the housing's NEMA 4X weatherproof integrity against water and water vapor.

### 5.1 CLEANING

The Model LXT-380 transmitter requires no periodic maintenance, except to make sure the front window is kept clean in order to permit a clear view of the display and allow proper operation of the navigation buttons. If the window becomes soiled, clean it using a soft damp cloth or soft tissue. To deal with more stubborn stains, a neutral detergent or spray cleaner like Windex may be used. Never use harsh chemicals or solvents.

### 5.2 REPAIR/SERVICE

Repairs on LXT-380 transmitter components may be accomplished only after declassifying the area and assuring that NO hazardous environment exists. Additionally, the power supplying the transmitter shall be de-energized.

Replacement of components may only be accomplished by replacing the complete three (3) circuit board assembly with similar parts. No board-level components are serviceable and shall be returned to the manufacturer for repair.

**Blank Page**

## 6.0 TROUBLESHOOTING

Symptom	Probable cause	Remedy
Blank Display	No Power	Check power source, 24VDC loop, 24VDC
	Sensor Failure, causing power draw down below transmitter threshold	Unplug sensor from transmitter, replace sensor if instrument powers up.
Incorrect Readings	Sensor needs calibration	Perform a standardization calibration. See INFO for calibration log
	Incorrect Temperature measurement  Temperature Compensation set up incorrectly	Calibrate/Trim Temperature to correct value  Verify: 0.33% for pH, plon 0.00% for ORP 4.0% for DO
"Looking For Sensor" prompt	Lost connection between sensor and transmitter	Check sensor connection to transmitter, loose connector? Visually inspect cable for cuts or crushed areas, replace sensor if cable is compromised

**Blank Page**

## 7.0 PARTS AND ACCESSORIES

### 7.1 REPLACEMENT PARTS

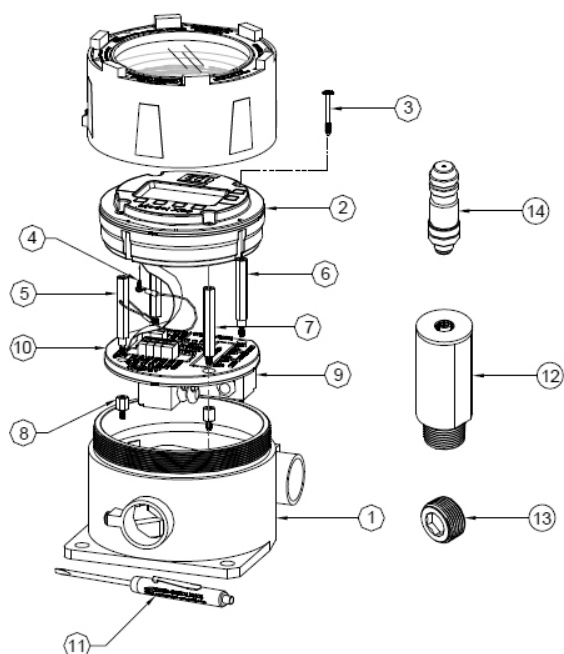

Item #	Part #	Description
1	9250055	Housing, X/P Stainless Steel 3/4" PORTS
2	2000150-x	Assembly, Module LXT-380 Sensor & Display
3	3200005	Screw, Stainless Steel 6-32x1 Modified
4	9730204	Screw, Stainless Steel #2x 1/4" Self-Tap
5	3000022	Lanyard, PCB Support LXT-380
6	3600566	Standoff, 1/4" HEX M/F 6-32x1.75" Stainless Steel Modified
7	9941626	Standoff, 1/4" HEX M/F 6-32x1.75" Stainless Steel
8	9941605	Standoff, 1/4" HEX M/F 6-32x 5/16" Stainless Steel
9	2100240-x	Assembly, PCB LXT-380 Connector Board
10	3400015	Cover LXT-380 Connector Board
11	9680044.1	Magnetic Screwdriver
12	9120019	Barrier, I/S LXT-380 to SP3X
13	9310062	Plug, Flameproof X/P 3/4" NPT Stainless Steel
14	9080837	Connector, M12 4POS Plug SP3X Sensor



**Blank Page**

## 8.0 SP3X SENSORS

---

SP3X sensors are a family of digital sensors designed for use with the Model LXT-380 transmitters. SP3X sensors accept the standard Teledyne electrode cartridges. The SP3X sensors convert the analog signals into a temperature compensated digital protocol that allows two way communications with the transmitter. The type of sensor, identity and serial number are stored in the sensor's memory along with three calibration registers. When connected to a Teledyne digital analyzer the sensor's information is uploaded to the analyzer configuring the displays and outputs to the values appropriate to the sensor's measured parameter. Connect an SP3X pH sensor to a Model LXT-380 Transmitter and the Transmitter configures itself into a calibrated pH transmitter.

The internal components of the SP3X sensors, the signal conditioner, temperature sensor and cable assembly are epoxy encapsulated inside the 3/4" O.D. housing. Epoxy encapsulation of the components increases the reliability of the sensor by eliminating failures caused by wiring and connector breakage. The SP3X sensors use the same easily replaceable electrode cartridges as the S10 and S17 sensor assemblies.

### 8.1 SP3X INSTALLATION

Four typical installation configurations are available for Teledyne sensors: insertion, immersion, flow-through and valve-retraction. Although there are many ways to accomplish these mounting configurations, Teledyne recommends the following installation configurations.

#### 8.1.1 INSERTION

The SP3X sensor is installed using a 3/4" MNPT compression fitting with choice of nylon, Teflon or 316 SS ferrule. The 3/4" MNPT can be inserted into a pipe Tee or through a tank wall, the SP3X is then inserted through the fitting and compression gland is tightened to secure the

sensor in place. The torque specification for the gland fitting is 20-ft/lbs. Over-tightening of the nut may swage the nylon or Teflon ferrules to the housing crushing the internal sensor components.

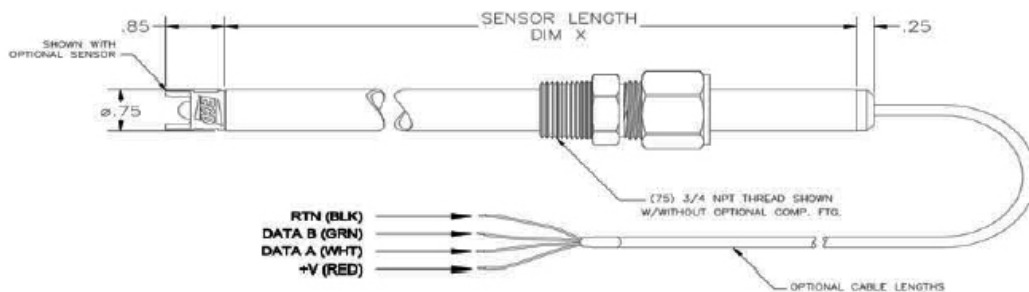

### 8.1.2 IMMERSION

The 3/4" MNPT compression fitting is reversed and threaded into an extension/immersion pipe so the compression gland is facing the measurement end of the sensor. Feed the cable through the immersion tube, insert the SP3X sensor at least 5" into the tube and tighten the sensor in place.

### 8.1.3 FLOW THROUGH

Although the insertion configuration can be used as a flow-through mounting by inserting the SP3X sensor into a pipe tee, Teledyne has various flow cells available for convenience. The flow cells are 2.0" diameter by 5" long, ported 1/2" FNPT through and 3/4" FNPT for the sensor. The flow cells are available in 316 Stainless Steel, PVC and Kynar. Use of the flow cell can facilitate an optional spray cleaning nozzle for the electrode. Connecting 40+ psi of water or air to the nozzle will remove particulate materials or biofilms from the sensor tip. Detergents or solvents can be used to remove greases or oils from the sensor while acids can be used for hard water scale.

### 8.1.4 VALVE RETRACTABLE

The SP3X sensor is optionally designed for valve retraction service, (-1) Sensor Style. Mounting is directly into a process line or through a

tank wall. The ball valve system allows the sensor to be removed from service without shutting down the line or emptying the tank. Teledyne recommends the valve-retraction mounting for ease of maintenance or in applications where the process line cannot be shut down and the pressure does not exceed 100 psig.

To remove the sensor from the valve assembly refer to the following directions:

**CAUTION:** *Do not put hands or fingers between the safety lanyard cables and any part of the sensor. Use the external cable seal/handle to pull or guide the sensor through the valve.*



1. Loosen the small swage nut at the rear of the fitting assembly slowly as this compression fitting is holding the sensor in place. **CAUTION** the sensor may snap back quickly if it is under pressure. (do not remove the nut from the body of the fitting).
2. Slide the sensor to its stop by pulling it through the ball valve. The safety lanyards will be extended, confirming that the sensor is fully retracted. Note: the safety lanyards are redundant protection; the sensor will come to a stop when the high pressure stop reaches the front of the retainer fitting.
3. Close the ball valve.
4. Remove the **handle retaining nut** and the valve handle.
5. Remove the **safety lanyards** from the valve stem.
6. For the stainless steel ball valves, loosen and remove the large **retainer nut** from the **retainer fitting**. For Kynar ball valves, loosen and remove the union nut on the sensor side of the ball valve.
7. Firmly pull the **retainer fitting** from the valve. The sensor will be removed with the fitting.

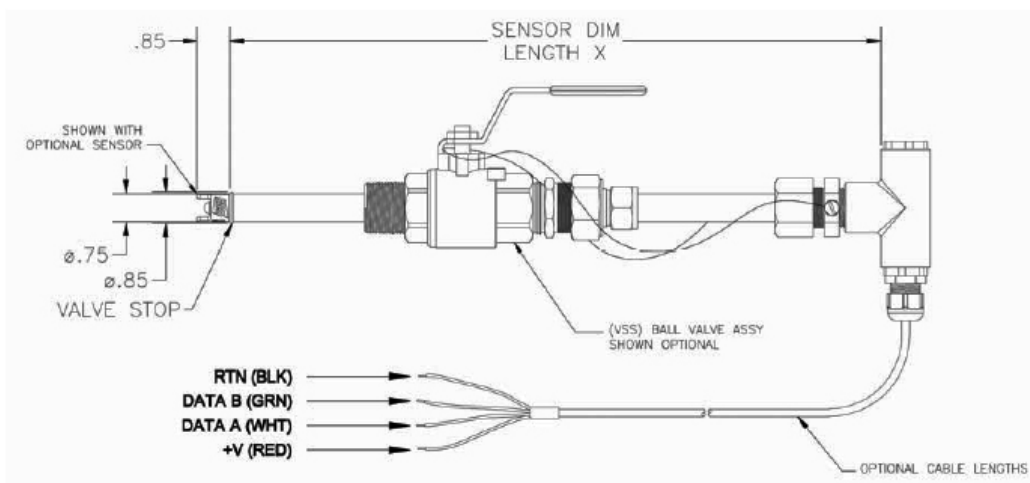

### 8.1.5 FLANGE FITTINGS

Flange mountings can be accomplished with the insertion and valve-retraction configurations using the desired flange and by mounting the gland fitting or valve-retraction assembly to the flange.

## 8.2 SP3X PART NUMBER CONFIGURATOR

SP3X sensors are available in five measurement types, (-0) a millivolt style for pH, ORP and ion selective measurements, (-1) dissolved oxygen style, (-2) contacting conductivity style, (-3) inductive conductivity style and (-4) resistivity style. Each style is available in a variety of materials and insertion lengths.

SP3X Digital Sensor	
<b>Measurement Type</b>	
-0	SP3X Digital Sensor, pH, ORP, pION measurement
-1	SP3X Digital Sensor, Dissolved Oxygen measurement
-2	SP3X Digital Sensor, Contacting Conductivity, 1µS to 50 mS
-5	SP3X Diagnostic Sensor, pH, ORP, pION measurement SENTINEL SP3X Sensor
-6	SP3X Digital sensor, ppb Dissolved Oxygen
-7	SP3X Digital Sensor, Resistivity
<b>Sensor Style</b>	
0	Insertion Style (Standard)
1	Valve Retractable Style with flanged blow out protector
<b>Housing Material</b>	
-0	Stainless Steel, ¾" O.D., (Standard)
-2	Hastelloy, ¾" O.D.
-5	Polypropylene, 1" O.D.
-9	Other Material, Consult with Factory
<b>Housing Length</b>	
0	10" length
1	17" length
2	24" length
3	30" length
4	36" length
<b>Process Connection</b>	
00	No Fitting or Valve Assembly
01 (75)	¾" MNPT SS Fitting with Nylon Ferrule
02 (75HT)	¾" MNPT, 316 SS gland, Teflon ferrule
03 (75SF)	¾" MNPT, 316 SS gland, SST ferrule
04 (75HC)	¾" MNPT, Hastelloy gland, Teflon ferrule
06 (75PP)	¾" MNPT, All Polypropylene gland fitting
07 (75K)	¾" MNPT, All Kynar gland Fitting
08 (75TFE)	¾" MNPT, All Teflon gland fitting
29	Other Fittings, Consult Factory
30 (VSS)	1" NPT 316 Stainless Steel Valve Retraction Assembly, nylon
31 (VSSHT)	1" NPT 316 Stainless Steel Valve Retraction Assembly, Teflon
32 (VSSE)	1" NPT 316 Stainless Steel Valve Retraction Assembly Toroidal
33 (VHC)	1" NPT Hastelloy Valve Retraction Assembly
36 (VPP)	1" NPT All Poly Propylene Valve Retraction Assembly
37 (VKY)	1" NPT All Kynar Valve Retraction Assembly
59	Other Assemblies, Consult Factory
80	1/1.5" Sanitary Flange, 316ss, Viton o-rings, nylon ferrule
81	2" Sanitary Flange, 316ss, Viton o-rings, nylon ferrule
82	2 ½" Sanitary Flange, 316ss, Viton o-rings, nylon ferrule
99	Other Fittings, Consult Factory
<b>Detachable Cable Connector</b>	
0	None
1	Straight (axial) Connector
2	Right Angle Connector

							<b>Cable Length</b>		
							-0 No Cable (Detachable Cable Version only)		
							-1 10 ft. (Standard)		
							-2 20 ft.		
							-3 30 ft.		
							-4 40 ft.		
							-5 50 ft.		
							-A 100 ft.		
							<b>"T" Handle</b>		
							0 No "T" Handle		
							1 (T) "T" Style handle with Lanyards for Valve Retractable		
							2 (TP) "T" Style handle, 3/8" polypro fitting (1000096)		
							3 (TS) "T" Style handle, 3/8" stainless steel fitting (1000098)		
							4 (TN) "T" Style handle , 1" Nylon fitting (1000104)		
							5 (TD) 3/4" Tee for INSERTION w/ Detachable Conn (2000092)		
							6 (TDV) 3/4" Tee for VALVE w/ Detachable Conn (2000166)		
							7 (1TD) 1" Tee for INSERTION w/ Detachable Conn (2000119)		
							8 (1TDV) 1" Tee for VALVE w/ Detachable Conn (2000118)		
							<b>O-rings Guard &amp; Fittings</b>		
							0 Viton Any/All		
							1 HF Viton Cond Guard		
							2 EPR Cond Guard		
							3 Kalrez Cond Guard		
							4 CV75 Cond Guard		
							5 HF Viton Valve & Fitting		
							6 EPR Valve & Fitting		
							7 Kalrez Valve & Fitting		
							9 CV-75 Valve & Fitting		
							A HF Viton Grd & Val & Fit		
							B EPR Grd & Val & Fit		
							C Kalrez Grd & Val & Fit		
							D CV-75 Grd & Val & Fit		
SP3X	-0	0	-0	0	01	-0	1	1	0

### 8.3 SP3X SENSOR MAINTENANCE

All electrochemical sensors require periodic cleaning and/or replacement. The life of an electrode is dependent on the process conditions it is exposed to, a pH electrode may last a year or longer in potable water and only a few weeks in a hot caustic bath. The chemical constituents in the process may coat the electrode surfaces requiring the electrode to be removed and cleaned or replaced.

Cleaning agents should be specific to the type of coating, detergents and alcohols for removing greases and oils, acids for

removing hard water scales and metallic deposits or spray washing for flocculants and biofilms.

### 8.3.1 ELECTRODE CARTRIDGE INSTALLATION

Unless ordered separately, electrode cartridges are generally shipped installed in a sensor. Sensors ordered without an electrode are shipped with a shipping plug to keep contamination from getting inside the sensor during shipment or storage. The following procedure explains how to install the electrode cartridge in the sensor assembly:

1. Remove the shipping plug by turning it counterclockwise.
2. Remove the electrode cartridge from the protective soaker boot. *Be careful not to flex the electrode body while removing the tape and the protective boot.*
3. Rinse the electrode tip in tap water and wipe the electrode body dry then lubricate the o-ring seals with the included lubricant. *Save the protective soaker boot in the event the electrode must be stored at a future time.*
4. Carefully insert the electrode cartridge into the sensor assembly by turning until **hand tight**. The first o-ring, closest to the front of the electrode, will be slightly visible if held horizontally.

*Note: If excess force is required during electrode installation, check for proper thread engagement or for an obstruction.*

### 8.3.2 ELECTRODE CARTRIDGE REPLACEMENT

Periodic replacement of the electrode cartridge is required for pH, ORP and Specific Ion sensors. The following procedure explains how to replace the electrode cartridge in the sensor assembly:

1. Remove the electrode cartridge from the front of the sensor assembly by turning it counterclockwise.
2. For installation procedure follow steps 2, 3, and 4 in section 8.3.1 electrode cartridge installation.



### 8.3.3 ELECTRODE CLEANING

An important aspect of sensor maintenance is the service of the electrode cartridge. After being in operation, an electrode may begin to exhibit slow response or non-reproducible measurements. This may be due to coating of the measurement electrode or clogging of the reference junction. Regular electrode cleaning reduces problems associated with the coating and clogging. Frequency of cleaning will depend on the process and application. The following procedures are used to clean pH and ORP electrodes.

If possible, the electrode should be cleaned without removing it from the sensor body. However, if the electrode must be removed, the o-rings must be inspected and re-lubricated. See section 3.10.

### 8.3.4 PH ELECTRODE CARTRIDGE CLEANING

Remove the sensor from the process and carefully wash the wetted end of the electrode cartridge in a mild solution of detergent and water or with methyl alcohol. If the electrode response is not improved, soak the electrode in 0.1 molar HCl for 5 minutes. Remove and rinse the electrode with tap water and soak in 0.1 molar NaOH for 5 minutes.

Remove the electrode from the NaOH solution, rinse the electrode and soak in a 4 pH buffer solution for 10 minutes. This should improve the response of the electrode. If not, replace the electrode.

If the electrode must be left out of the process for an extended period of time, store it in a solution of water saturated with KCl or a 4.0 pH buffer solution. *Teledyne does not recommend the storage of electrodes in distilled or deionized water.*

### 8.3.5 ORP ELECTRODE CARTRIDGE CLEANING

Cleaning the platinum surface to remove coating can be done using an abrasive cleaner like 600-800 grit wet/dry sand paper or chemical reagents specific for the type of coating. Abrasive cleaning is the most common method of cleaning and is usually sufficient to restore the platinum surface; however, some processes can form a hard coating requiring chemical cleaning with a strong acid solution. Acid solutions greater than 10% are not recommended.

### 8.3.6 PION ELECTRODE CARTRIDGE CLEANING

Ion selective electrodes require periodic service. Weekly checks should be performed to assure the accuracy of the measurement.

The ion selective crystal that senses the ion concentration can become sluggish in response due to coating or reactions with the process solution. Periodic cleaning or polishing will minimize drift and maintain the sensors response.

#### CLEANING

The solid state crystal based electrodes, bromide, chloride, copper, cyanide, fluoride, silver, sulfide are fairly robust and can be cleaned with alcohols, detergents or dilute acids to remove coatings caused by greases, oils or films. A soft tooth brush or paper towel should be used to remove stubborn coatings. Do not clean with a wire brush. Metal carryover from the brush will compromise the measurement. Cleaning should be followed by polishing before calibrating the sensor.

The PVC membrane sensors,  $\text{Ca}^{++}$ ,  $\text{K}^+$ ,  $\text{NH}_4^+$ ,  $\text{NO}_3^-$  are fragile membranes and should be cleaned using a soft artist style paint brush while rinsing with a stream of water. Dilute dish washing detergents can be used to remove oily films. Solvents or strong acid/alkaline solution will irreparably harm the electrode.

Calibration may be necessary after cleaning.

#### POLISHING

Abrasive polishing is only recommended for the solid state crystal style Combination Electrodes. Teledyne supplies two styles of abrasive cleaning kits, a package of light blue colored polishing strips or a small vial of 0.3 micron alumina powder with Q-tips with the fluoride electrodes.

The sensing surface of solid state electrodes can wear over time, which causes drift, poor reproducibility and loss of response in low level samples. The electrode can be restored by polishing the sensing surface with a polishing kit. The polishing kit can also be used if the sensing surface has been etched or chemically poisoned.

### Fluoride Electrodes

- a. Moisten the end of the Q-tip with water and dip it in the alumina polishing powder to pick up a small amount of the powder.
- b. Rub the polishing powder onto the fluoride crystal in a circular motion and moisten the tip if necessary to produce a liquid consistency more than a paste.
- c. Polish the electrode for about 30 seconds and examine the tip for a shiny surface, repeat if necessary.
- d. Rinse the electrode with distilled water and soak the electrode in a low ppm Calibration solution for a few minutes.
- e. Perform a Two Point Calibration.

### Other Solid State electrodes, Bromide, Cadmium, Chloride, Copper, Lead, Sulfide, Silver...

- a. Place a few drops of distilled water on the blue polishing strip to wet the polishing surface.
- b. Hold the electrode with the sensing surface facing up.
- c. Slide the polishing strip back and forth across the electrode tip, the sensing tip will be abraded and a new electrode surface will be generated.
- d. Polish the electrode for about 30 seconds and examine the tip for a shiny surface, repeat if necessary.
- e. Rinse the electrode with distilled water and soak the electrode in a low ppm Calibration solution for a few minutes.
- f. Perform a Two Point Calibration.

### 8.3.7 DISSOLVED OXYGEN CARTRIDGES

The Teflon membrane of the Dissolved Oxygen sensors is fragile and should be cleaned using a soft cloth or an artist style paint brush while rinsing with a stream of water. Dilute dish washing detergents can be used to remove oily films. Solvents are not recommended as they could diffuse through the membrane and harm the electrode. Strong acid/alkaline solutions should not harm the electrode but should only be used as a last resort before replacing the electrode.

### 8.3.8 CONDUCTIVITY AND RESISTIVITY SENSORS

Cleaning agents should be specific to the type of coating, detergents or alcohols for removing greases and oils, acids for removing hard water scales and metallic deposits or spray washing with water and a soft brush for flocculants and biofilms.

Resistivity sensors rarely need cleaning due to the nature of the measurement. If cleaning is necessary or the sensor has been in service for greater than two years follow the instructions listed below.

Rinse the sensing end with alcohol, methanol, ethanol or isopropyl will work fine.

Soak for 5 minutes in a dilute nitric acid solution, a 3.5% solution is made by a 20:1 dilution of concentrated Nitric Acid (5 ml HNO<sub>3</sub> in 100ml of water).

Then rinse thoroughly with tap water and soak in distilled water for 5-10 minutes.

## 8.4 SP3X SENSOR SPECIFICATIONS

**Dimensions:** SP3X - 3/4"OD x 10" Length.  
Optional lengths: 17", 24", 30", 36" .... in 6" increments to 8 ft.

**Cable Length:** 10' standard. Optional lengths in 10' increments, 4 conductors shielded.

**Housing Materials:** Standard, 316 Stainless Steel.  
Optional: Hastelloy (H), C-22.

**O-Ring Materials:** Viton™ (VIT), Standard, Ethylene Propylene (EPR).  
Optional: Fluoro-silicone (FSIL), Silicone (SIL), KALREZ™ (KLZ), CV75 (CV).

**Process Connections:**

-75: 3/4" 316 SS gland fitting with nylon ferrule.

-75PP: 3/4" poly propylene gland fitting with ferrule.

-75SF: 3/4" 316 SS gland fitting with stainless steel ferrule.

-75TFE: 3/4" Teflon™ gland fitting with Teflon™ ferrule.

-100: 1" Teflon™ glands fitting for PVDF housing only.

-VSS: 1" 316 SS valve retraction assembly.

-VKY: 1" PVDF valve retraction assembly.

**Shipping Weight:** SP3X 2.5 lbs (1.2 kg).  
SP3X with VSS 5.8 lbs (2.65 kg).

#### 8.4.1 PH ELECTRODES

Part#	Description	pH Range	Temperature	Max. Pressure
2005005-HPW	High Purity Water, RADEL Body, dbl jct TFE Ref, Full bulb pH glass,	2-12 pH	-10°-90°C	150 psig
2005145	General Purpose, RADEL body, dbl jct TFE Ref, Flat pH glass,	0-14 pH	-10°-90°C	150 psig
2005146	General Purpose, PEEK body, dbl jct ceramic Ref, Flat pH glass,	0-14 pH	-10°-90°C	150 psig
2005148	Non aqueous service, RADEL body, dbl jct TFE Ref, Flat pH glass,	0-14 pH	-10°-90°C	150 psig
2005157	Hi Temp/ Hi pH, PEEK body, dbl jct TFE Ref, Hemi pH glass,	0-14 pH	0°-130°C	150 psig
2005059	Recessed Bulb, RADEL Body, dbl jct TFE Ref, Hemi pH glass,	0-14 pH	-10°-90°C	150 psig
2005066	Chemical Resistant, PEEK body, triple jct TFE Ref, Flat pH glass,	0-14 pH	0°-130°C	150 psig
2005169	Chemical Resistant, PEEK body, dbl jct TFE Ref, Hemi pH glass,	0-14 pH	0°-130°C	150 psig
2005130	Sulfide Resistant, PEEK body, triple jct TFE Ref, Hemi pH glass,	0-14 pH	0°-130°C	150 psig
2005150	Solvent Resistant, PEEK body, dbl jct TFE Ref, Flat pH glass,	0-14 pH	-10°-90°C	150 psig
2005103	Fluoride resistant, Peek body, Rugged pH glass, dbl jct TFE Ref,	0-14 pH	-10°-90°C	150 psig
2005013	pH, antimony, RADEL body, TFE junction	3-10 pH	10°-50°C	150 psig

#### 8.4.2 ORP ELECTRODES

**Part#: 2005167 (2005367 SENTINEL)**

ORP sensor: Platinum

Construction: PEEK body,

Reference Electrode: double porous Teflon junction

Measurement Range: -1500 mV - +1500 mV

Temperature Range: -10° - 80°C

Pressure Range: 150 psig

### **8.4.3 DISSOLVED OXYGEN**

**Part#: 2005622**

2 mil Teflon membrane

Galvanic cell: Silver/Lead

Construction: PEEK body,

Measurement Range: 0-20 ppm

Temperature Range: -10° - 85°C

Pressure Range: 30 psig

### **8.4.4 AMMONIUM ELECTRODE**

**Part #: 2005083 (2005383 SENTINEL)**

ISE sensor: PVC membrane

Construction: Radel (PES) body,

Reference Electrode: double porous Teflon junction

Measurement range: 0.05 - 18,000 ppm

pH Range: 2-10 pH

Temperature Range: 0° - 40°C

Pressure Range: 50 psig

### **8.4.5 BROMIDE ELECTRODE**

**Part #: 2005062 (2005362 SENTINEL)**

ISE sensor: solid state AgS/AgBr membrane

Construction: Radel (PES) body,

Reference Electrode: double porous Teflon junction

Measurement range: 0.1 - 80,000 ppm

pH Range: 2-12 pH

Temperature Range: 0°-50°C

Pressure Range: 150 psig

### **8.4.6 CALCIUM ELECTRODE**

**Part #: 2005043 (2005343 SENTINEL)**

ISE sensor: PVC membrane

Construction: Radel (PES) body,  
Reference Electrode: double porous Teflon junction  
Measurement range: 0.1 - 40,000 ppm  
pH Range: 2.5 - 10 pH  
Temperature Range: 0°-40°C  
Pressure Range: 50 psig

#### **8.4.7 CHLORIDE ELECTRODE**

**Part #: 2005008 (2005308 SENTINEL)**

ISE sensor: solid state AgS/AgCl membrane  
Construction: Radel (PES) body,  
Reference Electrode: double porous Teflon junction  
Measurement range: 2 - 35,000 ppm  
pH Range: 2-12 pH  
Temperature Range: 0°-80°C  
Pressure Range: 150 psig

#### **8.4.8 CUPRIC ELECTRODE**

**Part #: 2005058 (2005358 SENTINEL)**

ISE sensor: solid state CuS membrane  
Construction: Radel (PES) body,  
Reference Electrode: double porous Teflon junction  
Measurement range: 1 ppb – 6,300 ppm  
pH Range: 2 - 8 pH  
Temperature Range: 0°-80°C  
Pressure Range: 150 psig

#### **8.4.9 CYANIDE ELECTRODE**

**Part #: 2005042 (2005342 SENTINEL)**

ISE sensor: solid state AgS/AgCN membrane  
Construction: Radel (PES) body,  
Reference Electrode: double porous Teflon junction  
Measurement range: 0.1- 260 ppm  
pH Range: 11-13 pH  
Temperature Range: 0°-80°C  
Pressure Range: 150 psig

**8.4.10 FLUORIDE ELECTRODE****Part #: 2005163 (2005363 SENTINEL)**

ISE sensor: solid state LaF crystal

Construction: PEEK body,

Reference Electrode: double porous Teflon junction

Measurement range: 0.02 - 2,000 ppm

pH Range: 5-8 pH

Temperature Range: 0° - 80°C

Pressure Range: 50 psig

**8.4.11 POTASSIUM ELECTRODE****Part #: 2005034 (2005334 SENTINEL)**

ISE sensor: PVC membrane

Construction: Radel (PES) body,

Reference Electrode: double porous Teflon junction

Measurement range: 0.1- 40,000 ppm

pH Range: 2-12 pH

Temperature Range: 0°-40°C

Pressure Range: 50 psig

**8.4.12 SILVER ELECTRODE****Part #: 2005016 (2005316 SENTINEL)**

ISE sensor: solid state AgS membrane

Construction: PEEK body,

Reference Electrode: double porous Teflon junction

Measurement range: 0.1-107,000 ppm

pH Range: 2-14 pH

Temperature Range: 0°-80°C

Pressure Range: 150 psig

**8.4.13 SODIUM ELECTRODE****Part #: 2005031 (2005331 SENTINEL)**

ISE sensor: Sodium selective Glass membrane

Construction: PEEK body,

Reference Electrode: double porous Teflon junction

Measurement range: 0.2 - 23,000 ppm

pH Range: 2-14 pH (pH must be 3 units higher than pNa)



Temperature Range: 0°-80°C

Pressure Range: 150 psig

#### **8.4.14 SULFIDE ELECTRODE**

**Part #: 2005122 (2005322 SENTINEL)**

ISE sensor: solid state AgS membrane

Construction: PEEK body,

Reference Electrode: double porous Teflon junction

Measurement range: 0.01 - 32,000 ppm

pH Range: 11-14 pH

Temperature Range: 0°-80°C

Pressure Range: 150 psig

## Appendix

---

### A. Auto Cal Buffer Tables

°C	pH	pH	pH
0	4.00	7.115	10.32
5	4.00	7.085	10.25
10	4.00	7.06	10.18
15	4.00	7.04	10.12
20	4.00	7.015	10.06
25	4.005	7.00	10.01
30	4.015	6.985	9.97
35	4.025	6.98	9.93
40	4.03	6.975	9.89
45	4.045	6.975	9.86
50	4.06	6.97	9.83
55	4.075	6.97	
60	4.085	6.97	
65	4.10	6.98	
70	4.13	6.99	
75	4.14	7.01	
80	4.16	7.03	
85	4.18	7.05	
90	4.21	7.08	

B. LXT-380 Hart Menu

LXT-380 Root Menu						
<b>1 DEVICE SETUP</b> 	<b>DEVICE SETUP</b>	<b>CALIBRATION</b>				
	<b>1 CALIBRATION</b>	<b>1 AUTO</b>				
		<b>2 STANDARDIZE</b>				
		<b>3 MANUAL</b>				
		<b>4 TEMP</b>				
	<b>2 BASIC SETUP</b>	<b>CONFIG</b>				
		<b>1 XMTR</b>	<b>XMTR CONFIG</b>	<b>1 ANALOG</b>	<b>1 SCALE</b>	<b>ANALOG SCALE</b>
						<b>1 UPPER</b>
				<b>2 LOWER</b>		
			<b>2 PID</b>	<b>PID CONFIG</b>	<b>1 P Term</b>	
					<b>2 I Term</b>	
					<b>3 D Term</b>	
			<b>3 CALIBRATE</b>	<b>CALIBRATE</b>	<b>1 Zero cal</b>	
					<b>2 Gain cal</b>	
		<b>3 Save</b>				
<b>2 ALARMS</b>	<b>ALARM CONFIG</b>	<b>1 Alrm 1 thresh</b>				
		<b>2 Alrm 1 hyst</b>				

				3 Alarm 1 dly on	
				4 Alarm 1 dly off	
				5 Alarm 2 thresh	
				6 Alarm 2 hyst	
				7 Alarm 2 dly on	
				8 Alarm 2 dly off	
				9 Alarm 3 thresh	
				10 Alarm 3 hyst	
				11 Alarm 3 dly on	
				12 Alarm 3 dly off	
			3 Address		
		2 Device information	DEVICE INFORMATION		
			1 Distributor		
			2 Model		
			3 Dev ID		
			4 Cfg chng count		
			5 Tag		
			6 Long tag		
			7 Date		
			9 Descriptor		
			10 Message		
			11 Final asmbly num		
	3 INFORMATION	INFORMATION			
		1 XMTR	XMTR INFO		
			1 Serial #		
			2 FW Rev		
			3 HW Rev		
			4 Fld dev rev		
		2 SENSOR	SENSOR INFO		
			1 Serial #		
			2 FW Rev		
			3 HW Rev		
		3 DEVICE	DEVICE INFORMATION		
			1 Distributor		
			2 Model		
			3 Dev ID		
			4 Cfg chng count		
			5 Tag		
			6 Long tag		
			7 Date		
			9 Descriptor		
			10 Message		
			11 Final asmbly num		
2 PV					
3 Temperature					
4 Output %					
5 Sensor Name					

## C. MODBUS RTU REGISTER LISTING

### 03 (0X03) READ HOLDING REGISTERS

This function code is used to read the contents of a contiguous block of holding registers in a remote device. The Request Protocol Data Unit specifies the starting register address and the number of registers. In the Protocol Data Unit Registers are addressed starting at zero. Therefore registers numbered 1-16 are address as 0-15.

The register data in the response message are packed as to bytes per register, with the binary contents right justified within each byte. For each register, the first byte contains the high order bits and the second contains the low order bits.

#### Request

Modbus ID (Slave Address)	1 Byte	1 to 247 (0x01 to 0xF7)
Function code	1 Byte	0x03
Starting Address	2 Bytes	0x0000 to 0xFFFF
Quantity of Registers	2 Bytes	1 to 125 (0x01 to 0x7D)
CRC	2 Bytes	calculated

#### Response

Modbus ID (Slave Address)	1 Byte	1 to 247 (0x01 to 0xF7)
Function code	1 Byte	0x03
Byte Count	1 Byte	2 X N*
Register Value(s)	*N X 2 Bytes	
CRC	2 Bytes	calculated
*N = Quantity of Registers		

#### Error

Modbus ID (Slave Address)	1 Byte	1 to 247 (0x01 to 0xF7)
Error Code	1 Byte	0x86
Exception Code	1 Byte	01, 02, 03 or 04
CRC	2 Bytes	calculated

**06 (0X06) WRITE SINGLE REGISTER**

This function code is used to write a single holding register in a remote device. The Request Protocol Data Unit specifies the address of the register to be written. Registers are addressed starting at zero. Therefore register number 1 is addressed as 0.

The normal response is an echo of the request, returned after the register contents have been written.

**Request**

Modbus ID (Slave Address)	1 Byte	1 to 247 (0x01 to 0xF7)
Function code	1 Byte	0x06
Register Address	2 Bytes	0x0000 to 0xFFFF
Register Value	2 Bytes	0x0000 to 0xFFFF
CRC	2 Bytes	calculated

**Response**

Modbus ID (Slave Address)	1 Byte	1 to 247 (0x01 to 0xF7)
Function code	1 Byte	0x06
Register Address	2 Bytes	0x0000 to 0xFFFF
Register Value	2 Bytes	0x0000 to 0xFFFF
CRC	2 Bytes	calculated

\*N = Quantity of Registers

**Error**

Modbus ID (Slave Address)	1 Byte	1 to 247 (0x01 to 0xF7)
Error Code	1 Byte	0x86
Exception Code	1 Byte	01, 02, 03 or 04
CRC	2 Bytes	calculated

## REGISTERS

Per the Modbus Application Protocol Specification (V1.1b)

Name	Meaning (2 bytes each register)	Number of Registers	Return Data Format	Read Write	Requires Storage Initiate	Register #	
						dec	hex
Modbus ID (slave address)	Defined as 1 to 247 per the Modbus Application Protocol Specification (V1.1b)	1	16 bit Integer	RW		0	00
Data Format	Data Format of the User Bus to the LXT-380 (0-DF8N2, 1-DF8O1, 2-DF8E1, 3-DF8N1)	1	16 bit Integer	RW		1	01
Baud Rate	Baud Rate of the User Bus to the LXT-380 (0-1200, 1-2400, 2-4800, 3-9600)	1	16 bit Integer	RW		2	02
BusMessage	total message count detected by the slave (remote device)	1	16 bit Integer	R		3	03
BusCommunicationsError	total CRC error count	1	16 bit Integer	R		4	04
SlaveExceptionError	total count of exceptions detected	1	16 bit Integer	R		5	05
SlaveMessage	total messages addressed to the slave (remote device)	1	16 bit Integer	R		6	06
SlaveNoResponse	total count of messages not responded to by the slave (remote device)	1	16 bit Integer	R		7	07
SlaveNAK	total Negative Acknowledges returned by slave (remote device)	1	16 bit Integer	R		8	08
SlaveBusy	total count of "slave busy" was returned for an address message	1	16 bit Integer	R		9	09
BusCharacterOverrun	count of messages that couldn't be handled due to character over-run condition	1	16 bit Integer	R		10	0A
Reset all Modbus Error Counters	Resets all of the Modbus Error counters (defined in Modbus spec) to 0, Write any value.	1	16 bit Integer	W		11	0B
Product LXT-380 Model Number (Modbus)	The Model Number of the Unit polled	1	16 bit Integer	R		12	0C
LXT-380 Serial Number (hi word)	Unit Serial Number (32 bit integer hi word, bytes 3 and 2)	2	32 bit Long Integer	R		13	0D
LXT-380 Serial Number (lo word)	Unit Serial Number (32 bit integer lo word, bytes 1 and 0)					14	0E
LXT-380 Mode	Unit operating mode (1-Startup, 2-Sensor Search, 3-Operate)	1	16 bit Integer	R		15	0F
LXT-380 Fault Status	Unit Fault flags, bit defined	1	16 bit Integer	R		16	10
LXT-380 2nd Fault Status	Unit Fault flags (2nd word reserved, currently not used)	1	16 bit Integer	R		17	11
LXT-380 Warning Status	Unit Warning flags, bit defined	1	16 bit Integer	R		18	12
LXT-380 2nd Warning Status	Unit Warning flags (2nd word reserved, currently not used)	1	16 bit Integer	R		19	13
LXT-380 FW Rev	Firmware revision of the Control BD in ASC, ex. " 1".	1	16 bit Integer	R		20	14
Relay Number to read/write	Relay number to access data (0 - Relay 1, 1 - Relay 2, 2 - Relay 3)	1	16 bit Integer	RW		21	15
Relay Type	Read/Write Relay Type (0 - Fault Type, 1 - Alarm Type, 2 - Disabled, 3 - Timed)	1	16 bit Integer	RW	Y	22	16

Relay ON Setpoint (hi word)	Read/Write Relay ON Setpoint (byte 3 and byte 2)	2	32 bit Floating Point	RW	Y	23	17
Relay ON Setpoint (lo word)	Read/Write Relay ON Setpoint (byte 1 and byte 0)					24	18
Relay OFF Setpoint (hi word)	Read/Write Relay OFF Setpoint (byte 3 and byte 2)	2	32 bit Floating Point	RW	Y	25	19
Relay OFF Setpoint (lo word)	Read/Write Relay OFF Setpoint (byte 1 and byte 0)					26	1A
Relay ON Delay (hi word)	Read/Write Relay turn on Delay time (byte 3 and byte 2)	2	32 bit Floating Point	RW	Y	27	1B
Relay ON Delay (lo word)	Read/Write Relay turn on Delay time (byte 1 and byte 0)					28	1C
Relay OFF Delay (hi word)	Read/Write Relay turn off Delay time (byte 3 and byte 2)	2	32 bit Floating Point	RW	Y	29	1D
Relay OFF Delay (lo word)	Read/Write Relay turn off Delay time (byte 1 and byte 0)					30	1E
Relay Energized State	Read/Write Relay 0 - Energized, 1 - De-Energized	1	16 bit Integer	RW	Y	31	1F
Relay Expiration	Read/Write Expiration Time, used with alarm type (0 - None, 2 - 5min., 3 - 10min., 4 - 15min., 6 - 30min.)	1	16 bit Integer	RW	Y	32	20
Relay Period	Read/Write Timed Relay Period (0 - 15min., 1 - 30min., 2 - 1hr., 3 - 2hr., 4 - 4hr., 5 - 8hr., 6 - 24hr.)	1	16 bit Integer	RW	Y	33	21
Relay Duration	Read/Write Timed Relay Duration (0 - 15sec., 1 - 30sec., 2 - 1min., 3 - 2min., 4 - 5min., 5 - 15min., 6 - 10min.)	1	16 bit Integer	RW	Y	34	22
Relay Hold Time	Read/Write Timed Relay Hold Time (0 - Off, 1 - held for the duration time, 2 - duration + 15sec., 3 - duration + 30sec., 4 - duration + 1min., 5 - duration + 2min., 6 - duration + 5 min., 7 - duration + 15min., 8 - duration + 30min.)	1	16 bit Integer	RW	Y	35	23
4-20 mA Channel Number to read/write	4-20 mA channel number to access data (0 - 1st 4-20mA, 1 - 2nd 4-20)	1	16 bit Integer	RW	Y	36	24
4-20 Analog Type	Read/Write 4-20 Type (0 - Range, 1 - Temperature, 2 - Sentinel)	1	16 bit Integer	RW	Y	37	25
4-20 Analog Range, 4mA range (hi word)	Read/Write 4mA range (bytes 3 and 2) applies to both range and temperature types	2	32 bit Floating Point	RW	Y	38	26
4-20 Analog Range, 4mA range (lo word)	Read/Write 4mA range (bytes 1 and 0) applies to both range and temperature types					39	27
4-20 Analog Range, 20mA range (hi word)	Read/Write 4mA range (bytes 3 and 2) applies to both range and temperature types	2	32 bit Floating Point	RW	Y	40	28
4-20 Analog Range, 20mA range (lo word)	Read/Write 4mA range (bytes 1 and 0) applies to both range and temperature types					41	29
Long Tag Line number to read/write	Tag Line number to access data (0 - Line 1, 1 - Line 2)	1	16 bit Integer	RW	Y	42	2A
Long Tag Line 1 (16 characters max)	ASCII character bytes 0 and 1, ex. "AB" A - 65 (41 hexadecimal), B - 66 (42 hex), send 6566 (4142 hex). The characters permitted are space ' ' (32 base 10, 20 hex) through 'J' 125 base 10, 7D hex).	1	16 bit Integer	RW	Y	43	2B
Long Tag Line	ASCII bytes 2 and 3	1	16 bit Integer	RW	Y	44	2C
Long Tag Line	ASCII bytes 4 and 5	1	16 bit Integer	RW	Y	45	2D
Long Tag Line	ASCII bytes 6 and 7	1	16 bit Integer	RW	Y	46	2E
Long Tag Line	ASCII bytes 8 and 9	1	16 bit Integer	RW	Y	47	2F
Long Tag Line	ASCII bytes 10 and 11	1	16 bit Integer	RW	Y	48	30
Long Tag Line	ASCII bytes 12 and 13	1	16 bit Integer	RW	Y	49	31
Long Tag Line	ASCII bytes 14 and 15	1	16 bit Integer	RW	Y	50	32
Initiate LXT-380 Parameter Storage	Signals the user has completed entering the data and wants it stored. Write any value.	1	16 bit Integer	RW		51	33
Sensor Channel to read/write	Sensor channel number to access data (0 - Sensor 1, 1 - Sensor 2)	1	16 bit Integer	RW		52	34
SP3X Mode	Unit operating mode (0-	1	16 bit Integer	R		53	35



SP3X Serial Number (hi word)	Unit Serial Number (32 bit integer hi word)	2	32 bit Long Integer	R		54	36
SP3X Serial Number (lo word)	Unit Serial Number (32 bit integer lo word)					55	37
SP3X Fault Status		1	16 bit Integer	R		56	38
SP3X Sensor Type	Specific SP3X sensor type (see SP3X Sensor Types tab)	1	16 bit Integer	R		57	39
SP3X Sensor Chemical Type	Specific chemicals the SP3X is set to detect (see SP3X Sensor Types tab)	1	16 bit Integer	RW	Y	58	3A
SP3X Max Range (hi word)	Max sensor range (bytes 3 and 2)	2	32 bit Floating Point	R		59	3B
SP3X Max Range (lo word)	Max sensor range (bytes 1 and 0)					60	3C
SP3X Min Range (hi word)	Min sensor range (bytes 3 and 2)	2	32 bit Floating Point	R		61	3D
SP3X Min Range (lo word)	Min sensor range (bytes 1 and 0)					62	3E
SP3X Sensor Value (hi word)	Current sensor value (bytes 3 and 2)	2	32 bit Floating Point	R		63	3F
SP3X Sensor Value (lo word)	Current sensor value (bytes 1 and 0)					64	40
SP3X Sensor Voltage (hi word)	Corresponding sensor voltage to the sensor value (byte 3 and byte 2)	2	32 bit Floating Point	R		65	41
SP3X Sensor Voltage (lo word)	Corresponding sensor voltage to the sensor value (byte 1 and byte 0)					66	42
SP3X Sensor Temperature (hi word)	Sensor Temperature (bytes 3 and 2)	2	32 bit Floating Point	R		67	43
SP3X Sensor Temperature (lo word)	Sensor Temperature (bytes 1 and 0)					68	44
SP3X Sensor is a Sentinel	Sensor is a Sentinel Type (0 - No, 1 - Yes)	1	16 bit Integer	R		69	45
SP3X Sentinel Life %	% of Sensor life remaining	1	16 bit Integer	R		70	46
SP3X Sentinel Vs (hi word)	Scaled Sentinel Voltage (in mV) normalized to Vo (bytes 3 and 2)	2	32 bit Floating Point	R		71	47
SP3X Sentinel Vs (lo word)	Scaled Sentinel Voltage (in mV) normalized to Vo (bytes 1 and 0)					72	48
SP3X Sentinel Vo (hi word)	Sentinel 100% value (in mV) on the life relative to 0V (bytes 3 and 2)	2	32 bit Floating Point	RW	Y	73	49
SP3X Sentinel Vo (lo word)	Sentinel 100% value (in mV) on the life relative to 0V (bytes 1 and 0)					74	4A
SP3X Sentinel Range (hi word)	Sentinel Range (bytes 3 and 2)	2	32 bit Floating Point	RW	Y	75	4B
SP3X Sentinel Range (lo word)	Sentinel Range (bytes 1 and 0)					76	4C
Sensor Full Name (18 characters max)	ASCII character bytes 0 and 1, ex. "AB" A - 65 (41 hexadecimal), B - 66 (42 hex), send 6566 (4142 hex). The characters permitted are space ' ' (32 base 10, 20 hex) through 'j' 125 base 10, 7D hex).	1	16 bit Integer	RW	Y	77	4D
Sensor Full Name	ASCII bytes 2 and 3	1	16 bit Integer	RW	Y	78	4E
Sensor Full Name	ASCII bytes 4 and 5	1	16 bit Integer	RW	Y	79	4F
Sensor Full Name	ASCII bytes 6 and 7	1	16 bit Integer	RW	Y	80	50
Sensor Full Name	ASCII bytes 8 and 9	1	16 bit Integer	RW	Y	81	51
Sensor Full Name	ASCII bytes 10 and 11	1	16 bit Integer	RW	Y	82	52
Sensor Full Name	ASCII bytes 12 and 13	1	16 bit Integer	RW	Y	83	53
Sensor Full Name	ASCII bytes 14 and 15	1	16 bit Integer	RW	Y	84	54
Sensor Full Name	ASCII bytes 16 and 17	1	16 bit Integer	RW	Y	85	
Sensor Abbreviated Name (8 characters max)	ASCII character bytes 0 and 1, ex. "AB" A - 65 (41 hexadecimal), B - 66 (42 hex), send 6566 (4142 hex). The characters permitted are space ' ' (32 base 10, 20 hex) through 'j' 125 base 10, 7D hex).	1	16 bit Integer	RW	Y	86	56

Sensor Abbreviated Name	ASCII bytes 2 and 3	1	16 bit Integer	RW	Y	87	57
Sensor Abbreviated Name	ASCII bytes 4 and 5	1	16 bit Integer	RW	Y	88	58
Sensor Abbreviated Name	ASCII bytes 6 and 7	1	16 bit Integer	RW	Y	89	59
Initiate SP3X Storage	Signals the user has completed entering the data and wants it stored. Write any value.	1	16 bit Integer	W		90	5A
Cal log number to read	Cal log number to read (0 - Cal Log 1, 1 - Cal Log 2, 2 - Cal Log 3)	1	16 bit Integer	RW		91	5B
SP3X Cal Log slope (hi word)	(bytes 3 and 2)	2	32 bit Floating Point	R		92	5C
SP3X Cal Log slope (lo word)	(bytes 1 and 0)					93	5D
SP3X Cal Log offset (hi word)	(bytes 3 and 2)	2	32 bit Floating Point	R		94	5E
SP3X Cal Log offset (lo word)	(bytes 1 and 0)					95	5F
SP3X Cal Log offset Voltage (hi word)	(bytes 3 and 2)	2	32 bit Floating Point	R		96	60
SP3X Cal Log offset Voltage (lo word)	(bytes 1 and 0)					97	61

### Fault Status

Bit #	bit meaning
0	Memory Error, either a Program Flash, RAM or NVM RAM checksum error has occurred
1	Input Voltage Out Of Tolerance
2	The On Board +12V is Out of Tolerance
3	The On Board +3.3V is Out of Tolerance
4	The Transmitter has lost communication link with the Sensor
5	There is no Sensor connected
6	Sensor Calibration Failed
7	Relay 1 on-time expired
8	Relay 2 on-time expired
9	Relay 3 on-time expired
10	Sentinel Error (useable life has expired)
11	Sentinel Poisoned
12	Membrane Error
13	NU
14	NU
15	NU

### WARNING STATUS

Bit #	bit meaning
0	The Sensor has changed from previously connect Sensor
1	Not Used (NU)
2	NU
3	NU
4	NU
5	NU
6	NU
7	NU
8	NU
9	NU
10	NU
11	NU
12	NU
13	NU
14	NU
15	NU

## Sensor Type

Data		Meaning		
Decimal	Hexadecimal	Chemical	Sensor Type	Measurement Units
0	0000	Unknown Chemical	None	None
1	0001	Ammonia	mV	ppm
2	0002	Ammonium	mV	ppm
3	0003	Bromide	mV	ppm
4	0004	Calcium	mV	ppm
5	0005	Chloride	mV	ppm
6	0006	Conductivity	Conductivity	S
7	0007	Cupric	mV	ppm
8	0008	Cyanide	mV	ppm
9	0009	DO	mV	ppm
10	000A	DO	mV	% saturation
11	000B	DO	mV	mg/L
12	000C	Fluoride	mV	ppm
13	000D	Hardness (CaCO <sub>3</sub> )	mV	ppm
14	000E	Nitrate	mV	ppm
15	000F	ORP	mV	mVa
16	0010	pH	mV	none
17	0011	Potassium	mV	ppm
18	0012	Resistivity	Conductivity	Ohm (W)
19	0013	Silver	mV	ppm
20	0014	Sodium	mV	ppm
21	0015	Sulfide	mV	ppm
22	0016	Turbidity	TR6	FNU
23	0017	Turbidity	TR6	NTU
24	0018	Turbidity	TR6	ppm
25	0019	Turbidity	TR6	mg/L
26	001A	Turbidity	TR6	% solid
27	001B	DO	DO80	ppm
28	001C	DO	DO80	% saturation
29	001D	DO	DO80	mg/L
30	001E	Calcium	mV	mg/L
31	001F	TDS	Conductivity	ppm
32	0020	Nitrite	mV	ppm
33	0021	TCA (max range)	TCA	mg/L
34	0022	TCA (min range)	TCA	mg/L
35	0023	FCA (max range)	FCA	mg/L
36	0024	FCA (min range)	FCA	mg/L

## D. RESISTIVITY TEMPERATURE COMPENSATION

The temperature coefficient of pure water changes with concentration and temperature. The graph below shows the % change per °C for 18.2 MΩ water. For the range of 20°- 40°C the mean value is -5% per °C, this is the default value set in the Model LXT-380. The temperature coefficient of 10 MΩ water drops to a mean value of -2.6%. The standard Resistivity temperature coefficient of -2.0%/°C is valid for all values below 1.0 MΩ water.

The Temperature Coefficient is set in CONFIG→SENSOR→T COMP→-5.000%

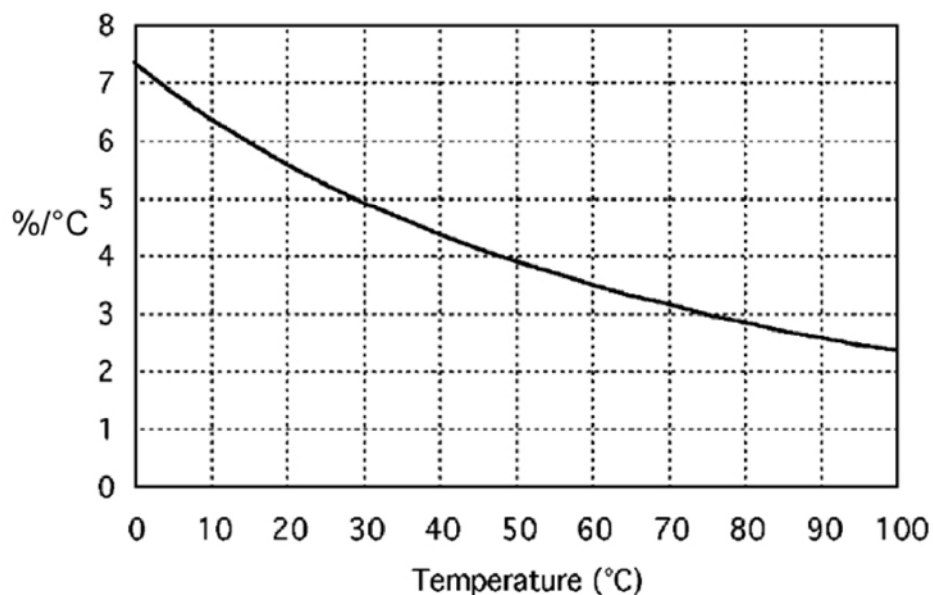

E. Drawings

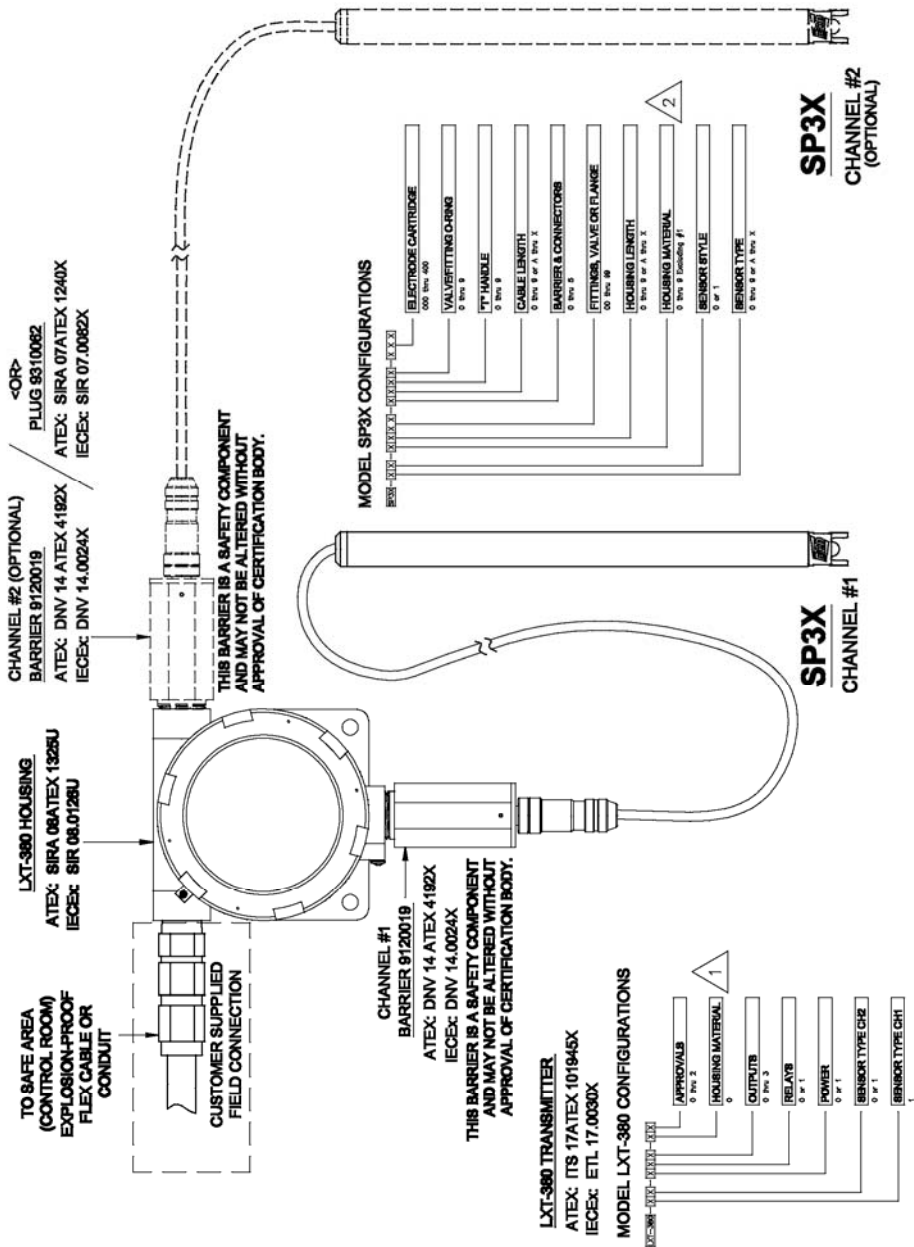

**2** DOES NOT CONTAIN, BY MASS, MORE THAN 10% IN TOTAL OF ALUMINUM, MAGNESIUM, TITANIUM AND ZIRCONIUM. DOES NOT CONTAIN, BY MASS, MORE THAN 7.5% IN TOTAL OF MAGNESIUM, TITANIUM AND ZIRCONIUM.

**1** DOES NOT CONTAIN, BY MASS, MORE THAN 7.5% IN TOTAL OF MAGNESIUM; TITANIUM AND ZIRCONIUM.

DO NOT CHANGE WITHOUT AUTHORIZATION OF CERTIFICATION AGENCY.

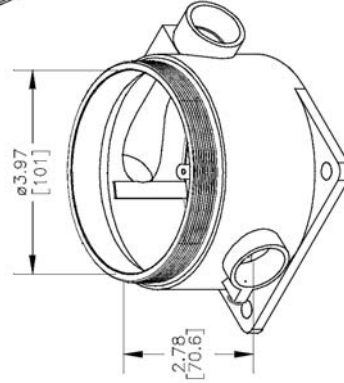
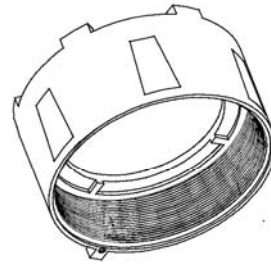
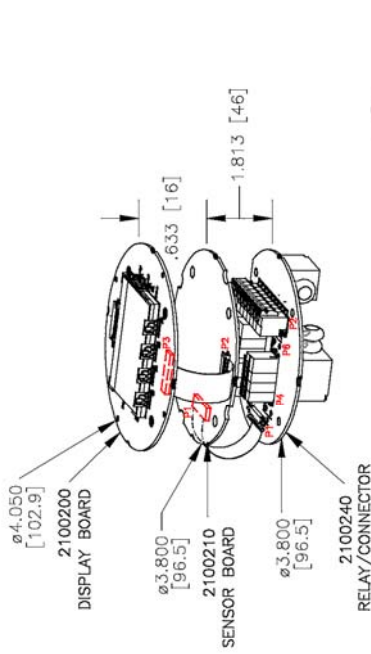

**LXT-380 VOLUME**  
 EMPTY: 640 CC  
 POPULATED: 190 CC  
 FREE: 450 CC

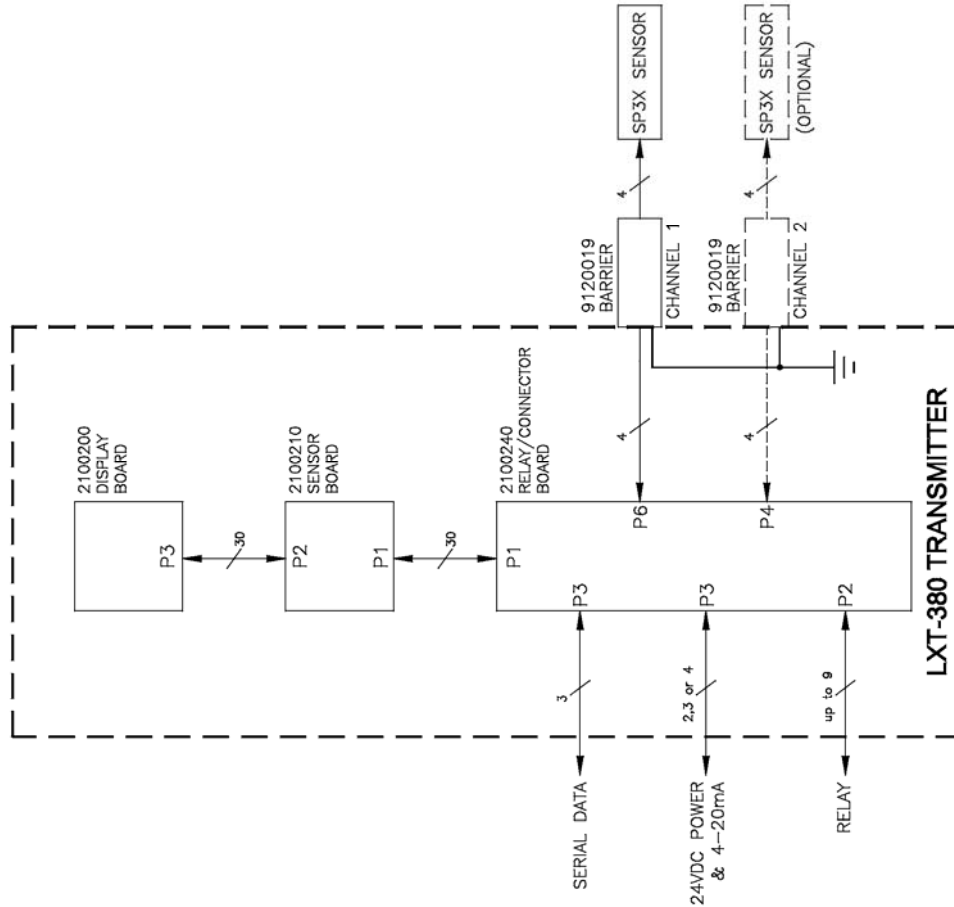

DO NOT CHANGE WITHOUT AUTHORIZATION OF CERTIFICATION AGENCY.

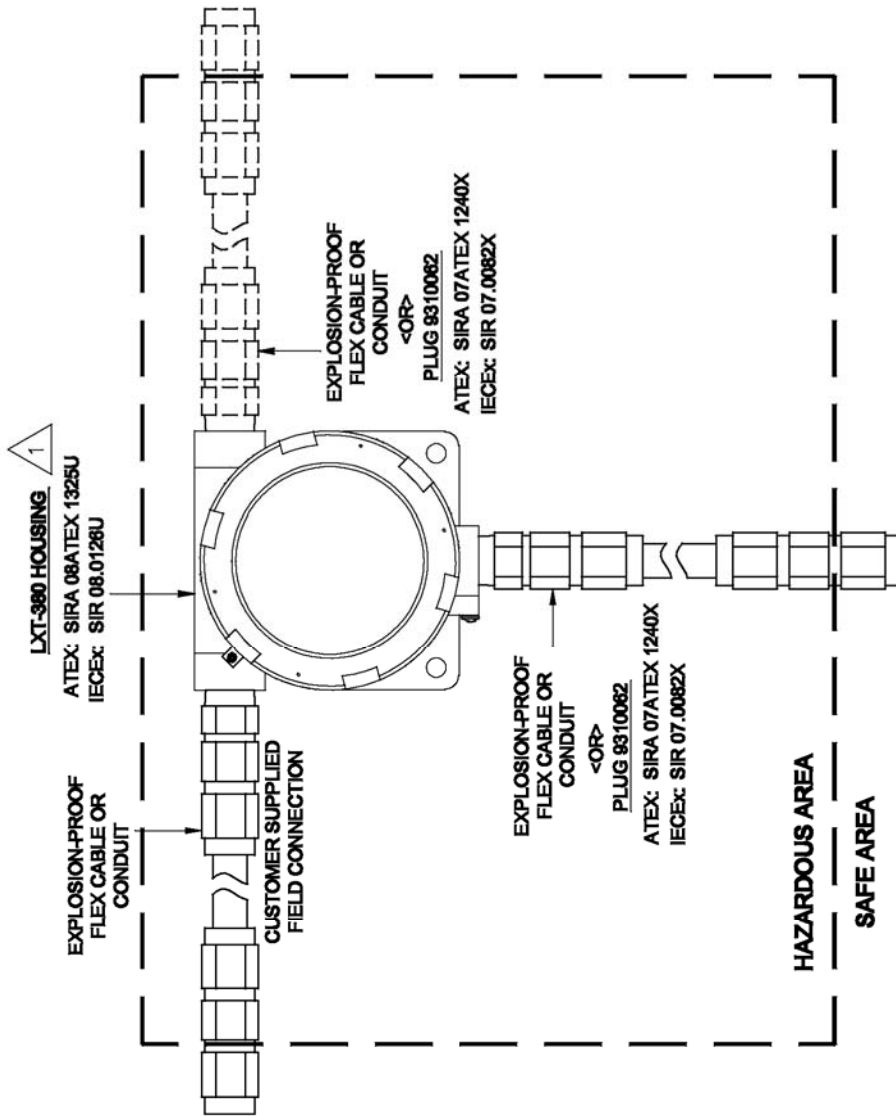

1 DOES NOT CONTAIN, BY MASS, MORE THAN 7.5% IN TOTAL OF MAGNESIUM; TITANIUM AND ZIRCONIUM. **DO NOT CHANGE WITHOUT AUTHORIZATION OF CERTIFICATION AGENCY.**

## F. Company Address

**TELEDYNE ELECTRONIC TECHNOLOGIES**  
***Analytical Instruments***

16830 Chestnut Street  
City of Industry, CA 91748

Telephone: (626) 934-1500  
Fax: (626) 961-2538

Web: [www.teledyne-ai.com](http://www.teledyne-ai.com)  
or your local representative

email: [ask\\_tai@teledyne.com](mailto:ask_tai@teledyne.com)

**IMPORTANT:** Orders for replacement parts should include the model number, serial number, and range of the analyzer for which the parts are intended.