

Use and Disclosure of Data
Information contained herein is classified as EAR99 under the
U.S. Export Administration Regulations.
Export, reexport or diversion contrary to U.S. law is prohibited.

INSTRUCTION, OPERATING AND MAINTENANCE MANUAL FOR

GC-PRO TCD



P/N M89443
DATE 4/05/13



DANGER



Toxic and/or flammable gases or liquids may be present in this monitoring system. Personal protective equipment may be required when servicing this instrument. Hazardous voltages exist on certain components internally which may persist for a time even after the power is turned off and disconnected. Only authorized personnel should conduct maintenance and/or servicing. Before conducting any maintenance or servicing, consult with authorized supervisor/manager.

Copyright © 2013 Teledyne Analytical Instruments

All Rights Reserved. No part of this manual may be reproduced, transmitted, transcribed, stored in a retrieval system, or translated into any other language or computer language in whole or in part, in any form or by any means, whether it be electronic, mechanical, magnetic, optical, manual, or otherwise, without the prior written consent of Teledyne Analytical Instruments, 16830 Chestnut Street, City of Industry, CA 91748.

Warranty

This equipment is sold subject to the mutual agreement that it is warranted by us free from defects of material and of construction, and that our liability shall be limited to replacing or repairing at our factory (without charge, except for transportation), or at customer plant at our option, any material or construction in which defects become apparent within one year from the date of shipment, except in cases where quotations or acknowledgements provide for a shorter period. Components manufactured by others bear the warranty of their manufacturer. This warranty does not cover defects caused by wear, accident, misuse, neglect or repairs other than those performed by Teledyne or an authorized service center. We assume no liability for direct or indirect damages of any kind and the purchaser by the acceptance of the equipment will assume all liability for any damage which may result from its use or misuse.

We reserve the right to employ any suitable material in the manufacture of our apparatus, and to make any alterations in the dimensions, shape or weight of any parts, in so far as such alterations do not adversely affect our warranty.

Important Notice

This instrument provides measurement readings to its user, and serves as a tool by which valuable data can be gathered. The information provided by the instrument may assist the user in eliminating potential hazards caused by his process; however, it is essential that all personnel involved in the use of the instrument or its interface be properly trained in the process being measured, as well as all instrumentation related to it.

The safety of personnel is ultimately the responsibility of those who control process conditions. While this instrument may be able to provide early warning of imminent danger, it has no control over process conditions, and it can be misused. In particular, any alarm or control systems installed must be tested and understood, both as to how they operate and as to how they can be defeated. Any safeguards required such as locks, labels, or redundancy, must be provided by the user or specifically requested of Teledyne at the time the order is placed.

Therefore, the purchaser must be aware of the hazardous process conditions. The purchaser is responsible for the training of personnel, for providing hazard warning methods and instrumentation per the appropriate standards, and for ensuring that hazard warning devices and instrumentation are maintained and operated properly.

Teledyne Analytical Instruments, the manufacturer of this instrument, cannot accept responsibility for conditions beyond its knowledge and control. No statement expressed or implied by this document or any information disseminated by the manufacturer or its agents, is to be construed as a warranty of adequate safety control under the user's process conditions.



Safety Messages

Your safety and the safety of others are very important. We have provided many important safety messages in this manual. Please read these messages carefully.

A safety message alerts you to potential hazards that could hurt you or others. Each safety message is associated with a safety alert symbol. These symbols are found in the manual and inside the instrument. The definition of these symbols is described below:



GENERAL WARNING/CAUTION: Refer to the instructions for details on the specific danger. These cautions warn of specific procedures which if not followed could cause bodily Injury and/or damage the instrument.



CAUTION: HOT SURFACE WARNING: This warning is specific to heated components within the instrument. Failure to heed the warning could result in serious burns to skin and underlying tissue.



WARNING: ELECTRICAL SHOCK HAZARD: Dangerous voltages appear within this instrument. This warning is specific to an electrical hazard existing at or nearby the component or procedure under discussion. Failure to heed this warning could result in injury and/or death from electrocution.



Technician Symbol: All operations marked with this symbol are to be performed by qualified maintenance personnel only.

No
Symbol

NOTE: Additional information and comments regarding a specific component or procedure are highlighted in the form of a note.



STAND-BY: This symbol indicates that the instrument is on Stand-by but circuits are active.

CAUTION: THE ANALYZER SHOULD ONLY BE USED FOR THE PURPOSE AND IN THE MANNER DESCRIBED IN THIS MANUAL.



IF YOU USE THE ANALYZER IN A MANNER OTHER THAN THAT FOR WHICH IT WAS INTENDED, UNPREDICTABLE BEHAVIOR COULD RESULT POSSIBLY ACCOMPANIED WITH HAZARDOUS CONSEQUENCES.

This manual provides information designed to guide you through the installation, calibration and operation of your new analyzer. Please read this manual and keep it available.

Occasionally, some instruments are customized for a particular application or features and/or options added per customer requests. Please check the front of this manual for any additional information in the form of an Addendum which discusses specific information, procedures, cautions and warnings that may be specific to your instrument.

Manuals do get misplaced. Additional manuals can be obtained from Teledyne at the address given in the Appendix. Some of our manuals are available in electronic form via the internet. Please visit our website at: www.teledyne-ai.com.

Additional Safety Information

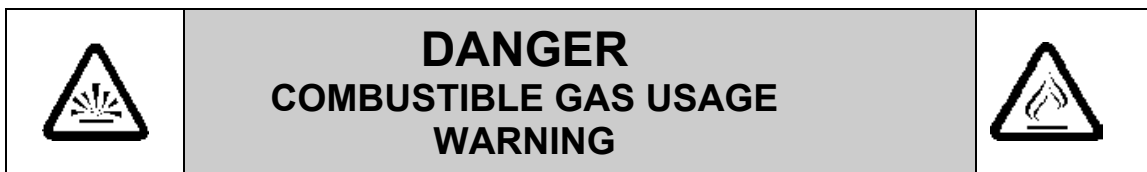

This is a general purpose instrument designed for use in a non-hazardous area. It is the customer's responsibility to ensure safety especially when combustible gases are being analyzed since the potential of gas leaks always exist.

The customer should ensure that the principles of operating of this equipment are well understood by the user. Misuse of this product in any manner, tampering with its components, or unauthorized substitution of any component may adversely affect the safety of this instrument.

Since the use of this instrument is beyond the control of Teledyne, no responsibility by Teledyne, its affiliates, and agents for damage or injury from misuse or neglect of this equipment is implied or assumed.

WARNING: *If toxic or flammable gases are used, always purge the entire system before performing any maintenance and always leak check the system after removing any tubing or fittings on the sample system. See the procedures for purging and leak checking this instrument on the following pages.*



If toxic gases or other hazardous materials are introduced into the sample system, the same precautions regarding leak checking and purging apply to the sample lines and sample supply or delivery lines.

WARNING: *ELECTRICAL SHOCK HAZARD. ONLY AUTHORIZED AND SUITABLY TRAINED PERSONNEL SHOULD PERFORM WORK INSIDE OF THE INSTRUMENT. COMPONENTS WITHIN THE COVER, INSIDE THE ISOTHERMAL CHAMBER (SAMPLE SYSTEM), AND ON PC BOARDS MAY CONTAIN DANGEROUSLY HIGH VOLTAGE SUFFICIENT TO CAUSE SERIOUS INJURY OR DEATH.*



There are the following three types of inaccessible shock hazards within the Analyzer:

- 1. Line voltages and line related voltages such as 115 VAC which exists within the 230 VAC versions as well. These voltages stop when the Analyzer is turned off and the mains (line) cord is removed from the instrument.*
- 2. External hazardous voltages which may be connected to the Analyzer alarm relay connections.*

WARNING: *THIS INSTRUMENT IS DESIGNED TO BE OPERATED IN A NONHAZARDOUS AREA. DEPENDING ON THE APPLICATION, TOXIC GASES OR FLAMMABLE/EXPLOSIVE GASES MAY BE PRESENT. IT IS THEREFORE, THE CUSTOMER'S RESPONSIBILITY TO ENSURE THAT PROPER TRAINING AND UNDERSTANDING OF THE PRINCIPLES OF OPERATION OF THIS EQUIPMENT ARE UNDERSTOOD BY THE USER. SINCE THE USE OF THIS INSTRUMENT IS BEYOND THE CONTROL OF TELEDYNE, NO RESPONSIBILITY BY TELEDYNE, ITS AFFILIATES AND AGENTS FOR DAMAGE OR INJURY RESULTING FROM MISUSE OR NEGLIGENCE OF THIS INSTRUMENT IS IMPLIED OR ASSUMED. MISUSE OF THIS PRODUCT IN ANY MANNER, TAMPERING WITH ITS COMPONENTS OR UNAUTHORIZED SUBSTITUTION OF ANY COMPONENT MAY ADVERSELY AFFECT THE SAFETY OF THIS INSTRUMENT.*



CAUTION: *WHEN OPERATING THIS INSTRUMENT, ALL COVERS SECURELY FASTENED. THE GAUGES*



**MUST BE IN PROPER WORKING ORDER. DO NOT
OVERPRESSURIZE THE SYSTEM.**

**READ THIS MANUAL BEFORE OPERATING THE
INSTRUMENT AND ADHERE TO ALL WARNINGS
INCLUDED IN THIS MANUAL.**

Table of Contents

Safety Messages	iii
Additional Safety Information	v
List of Figures	xii
List of Tables	xiii
Introduction	1
1.1 Main Features of the Analyzer	1
1.2 Principle of Operation	3
1.3 Analyzer Description	3
1.4 Applications	7
Operational Theory	9
2.1 Introduction	9
2.2 Modes of Operation	10
2.3 Analyzer Subsystems	11
2.3.1 Sample System	11
2.3.2 Gas Flow Control System	12
2.3.3 Gas Separation System	14
2.4 Detector Cell	14
Installation	17
3.1 Unpacking the Analyzer	17
3.2 Mounting the Analyzer	17
3.3 User Connections	18
3.3.1 Electrical Power Connections	18
3.3.2 Electronic Connections	18
3.3.2.1 Primary Input Power	19
3.3.2.2 Fuse Installation	20

3.3.2.3 50-Pin Equipment Interface Connector	20
3.3.2.4 Analog Output	20
3.3.2.5 Alarm Relays	22
3.3.2.6 Digital Remote Cal Inputs	24
3.3.2.7 'Measure Once' (or one shot measurement) contacts	25
3.3.2.9 Pin Out Table	25
3.3.2.10 RS-232 Port	28
3.3.3 Gas Connections	29
3.3.3.1 Effluent	31
3.3.3.2 Sensor Vent	31
3.3.3.3 Carrier Gas Connection	31
3.3.4 Sample and Span Gas Connections	31
3.4 Placing the System in Operation	32
Operation	33
4.1 Equipment	34
4.2 Preliminary Power-Off Check List	34
4.3 Powering Up the Unit	35
4.4 Activating the Support Gases	38
4.4.1 Carrier Gas	38
4.4.2 Span Gas	38
4.5 Analyzer Operation	38
4.5.1 Default Parameters	39
4.5.2 The HOME Screen	40
4.5.3 The MENU Screen	41
4.5.4 Standby	42
4.5.5 Overlay Chromatogram	44
4.5.6 Timing	46
4.5.6.1 TCD Amplifier Gain	50
4.5.7 Temperature	50

4.5.7.1 Thermocouple	51
4.5.7.2 Settings	52
4.5.7.3 PID Settings	53
4.5.7.4 Status	54
4.5.8 Group Setup	55
4.5.9 Analog Adjust	58
4.5.10 Calibration	59
4.5.10.1 Span	60
4.5.10.2 Alt Span	62
4.5.10.3 Auto cal	65
4.5.11 Self Test	66
4.5.12 Settings	68
4.5.12.1 Alarms	69
4.5.12.2 Range	72
4.5.12.3 Change Stream	74
4.5.12.4 Time	75
4.5.12.5 Password	76
4.5.12.6 Communication	76
4.5.12.7 Detector	78
4.5.12.8 Set TCD	79
4.5.12.9 Cycle Mode	80
4.5.13 Analysis Mode	80
4.5.13.1 T-Time	81
4.5.13.2 T_Cycle	82
4.5.13.3 Chromatogram	83
4.5.13.4 VS Count	85
4.5.13.5 Cold Boot	85
Maintenance & Troubleshooting	89
Appendix	91
A.1 Specifications and Initial Settings:	91



GC-Pro TCD

A.2 Recommended Spare Parts List	92
A.3 Drawing List	93
Appendix B	95
B1. VNC for GC-Pro TCD	95
Appendix C	101
C1 Addendum and Testing Results	101

List of Figures

Figure 1-1: GC-Pro TCD Front Panel.....	4
Figure 1-2: GC-Pro TCD Rear Panel	5
Figure 1-3: Internal PCB Arrangement.....	6
Figure 1-4: GC-Pro TCD Internal View.....	6
Figure 2-1: Internal Temperature Controllers	12
Figure 2-2: Typical Piping Diagram Used in the GC-Pro TCD.....	13
Figure 2-3: Thermal Conductivity Cell Operating Principle.....	14
Figure 3-1: GC-Pro TCD Rear Panel with Optional Gas Manifold.	19
Figure 3-2: Equipment Interface Connector Pin Arrangement.....	20

List of Tables

Table 3-1: Analog Output Connections — Middle Connector 21

Table 3-2: Analog Concentration Output—Example..... 22

Table 3-3: Alarm Relay Contact Pins — Top Connector 23

Table 3-4: Remote Calibration Connections — Bottom Connector 24

Table 3-5: ‘Measure Once’ Relay Connections 25

Table 3-6: Pin out of Alarm Relay O/P (Top) 50 pin D-Sub
Connector 26

Table 3-7: Pin out of Analog Signal (Middle) 50 pin D-Sub
Connector 26

Table 3-8: Pin out of Standard (Bottom) 50 pin D-Sub Connectors 27

Table 3-9: Commands via RS-232 Input 28

Table 3-10: Required RS-232 Options 28

Introduction

The GC-Pro TCD Analyzer is a microprocessor controlled digital instrument incorporating a Thermal Conductivity Detector (TCD) coupled with a gas separation column and switching valve designed to measure the quantity of aromatic hydrocarbons present in a positive pressure sample gas. Up to 8 channels of output are present for measuring specific analytes in a sample stream. In using a thermal conductivity detector after gas separation through a column, the range of analysis is extended to include additional phase separable inert, or other difficult to analyze gas phase components like N₂, H₂. etc. that are present in a positive pressure sample gas.

The GC-Pro TCD Analyzer has multiple channels for measurement with enhanced versatility and capabilities. Due to its flexibility, it is vitally important that you refer to Appendix C for the specific factory setup for your application.

The GC-Pro TCD features a modern user interface with a touch screen front panel facilitating operation, calibration, data collection and display. With the Ethernet connectivity feature, this new interface allows the instrument to be operated remotely with a VNC software application from another digital device whereby the analyzer can be accessed, controlled, data displayed etc. as if the analyzer were physically present.

Although the analyzer arrives already setup for your specific application, a gas chromatograph mode allows the user to program the instrument for measuring different species present in the sample.

1.1 Main Features of the Analyzer

The GC-Pro TCD Analyzer is sophisticated yet simple to use. A touch screen display on the front panel provides access all phases of setup, calibration, operation, and troubleshooting on the GC-Pro TCD.

The main features of the analyzer include:

- Stable, accurate thermal conductivity detector for analyzing inert gases and other species not amenable to flame ionization detection.

- Data acquisition and control functions supporting:
 - Pressure measurements, 5-Channels (Future option)
 - Flow (MFC) measurements, 3-Channels (Future option)
 - Oxygen measurements, 6-Channels (Future option)
 - Temperature measurements and control, 4-Channels
 - 6-Channel Dew point Hygrometer measurements, 6-Channel (Future option)
 - Relay, (10) and solenoid outputs, (4)
 - Alarm, (3) and over range indication outputs, (4)
 - 4-20mA current loop outputs, 10 channels
 - HMI through Maple touch sensitive display
- The system operates at single phase AC, 110 or 220V 50/60 Hz (select at time of order).
- High resolution, accurate readings of concentration.
- Versatile analysis with three user-definable analysis ranges.
- Microprocessor based electronics: 8-bit CMOS microprocessor with 32 kB RAM and 128 kB ROM.
- Auto ranging allows analyzer to automatically select the proper preset range for a given measurement. Manual override allows the user to lock onto a specific range of interest.
- Two adjustable concentration alarms and a system failure alarm.
- Extensive self-diagnostic testing at startup and on demand with continuous power supply monitoring.
- RS-232 serial digital port for use with a computer or other digital communication device.
- 8-Analog outputs for concentration and range identification (0-1 VDC standard and isolated 4-20 mA dc).
- Superior Accuracy

1.2 Principle of Operation

The analyzer uses a sample valve which is a specialized electronic-controlled valve responsible for extracting a precise volume of sample and delivering it to the separation column. This valve uses four micro cavities and rotates between two positions in a timed fashion controlled by the timing function in the control section.

The gas separation column separates the component of interest in the sample gas based on its retention time in the packed column. Using a carrier gas and a microprocessor actuated switching valve, the eluted gas is analyzed using a Thermal Conductivity Detector (TCD). After each injection cycle the column is back flushed to accept the fresh sample in the next cycle. The result is a series of peaks over time corresponding to the detector output for each sample cycle. The integrated area under the peak is directly related to concentration and after signal processing, this result is displayed in the appropriate units on the screen. The screen is updated after each cycle.

1.3 Analyzer Description

The standard analyzer is a rack mountable instrument designed to fit into a standard 19" instrument rack. The front interface screen is mounted on the left side of the panel. The right side of the panel includes the gas controls, pressure gauges and flowmeter. The front panel is shown in Figure 1-1.

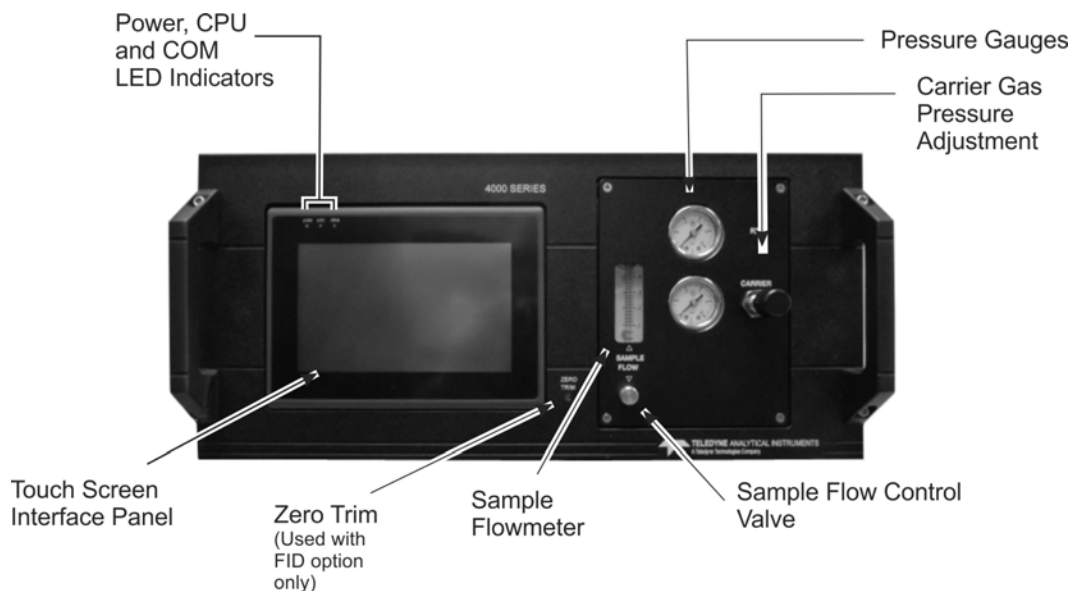

Figure 1-1: GC-Pro TCD Front Panel

Gas pressure gauges and controls are mounted on the front panel adjacent to the touch screen (human/machine interface abbreviated as HMI) display as shown in Figure 1-1.

At the rear of the instrument are ports for the introduction of air, zero, span, and sample gas as well as vent port connections. Three 50-pin user-interface cable connectors route input/output and alarm signals to external devices. RS232 and a network port are also available at the rear panel for connection to a remote computer or other digital communication device. Internally, there are two USB user connections which are used for updating firmware to the PCBs. Figure 1-2 shows the rear panel including the user connections.

The analyzer is set up for either 120 VAC 60 Hz or 230 50/60 Hz operation depending on the customer's requirements. The appropriate power cord for your unit is included with the analyzer.

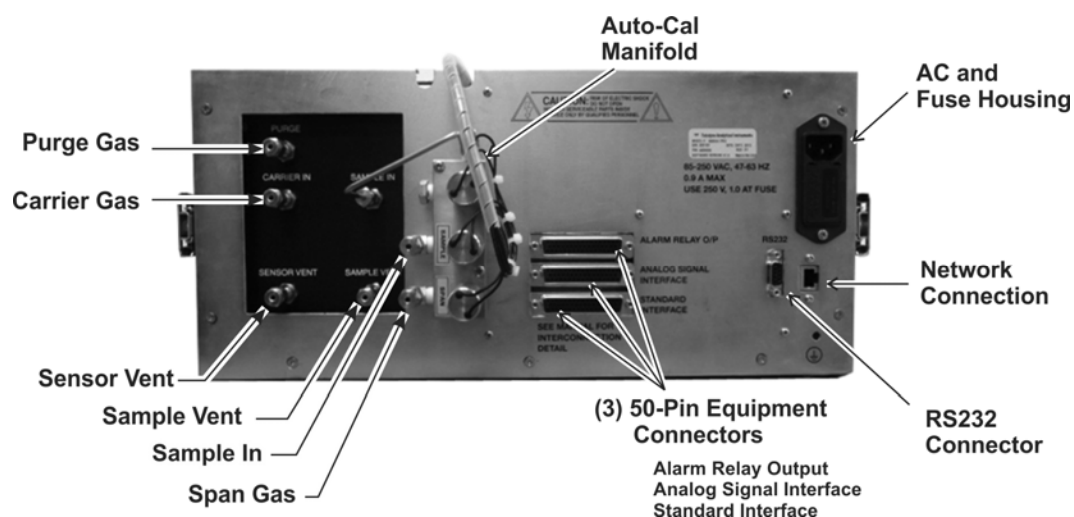

Figure 1-2: GC-Pro TCD Rear Panel

Internally, there are three isothermal chambers each separately controlled for precise control and separation of analyzed species. In the electronics section, internal PC boards are stacked in an assembly in an order based on inter connectivity needs between the PCBs as well as their association with other sub assemblies distributed within the system. See Figure 1-3.

Following is the card stack-up from top to bottom planned inside the system

- Heater card
- 9261 controller card
- Analog data acquisition card
- Analog signal conditioning card
- 89C5131 controller card

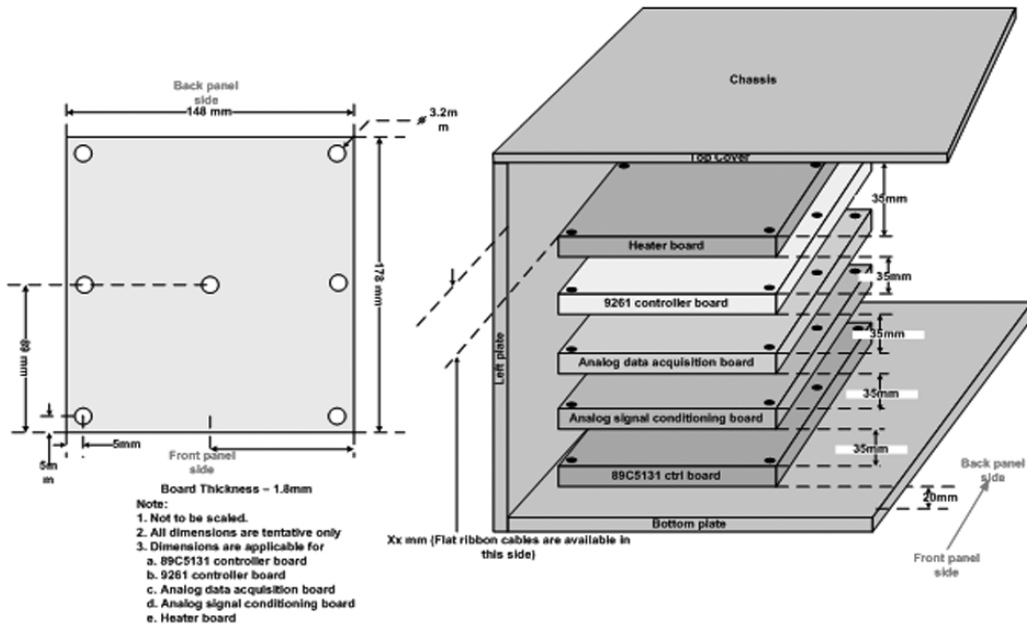

Figure 1-3: Internal PCB Arrangement



Figure 1-4: GC-Pro TCD Internal View

1.4 Applications

- Monitoring the benzene concentration of carbon dioxide gas for use in the beverage industry.
- Monitoring aromatic contamination in air liquefaction and other gas production processes.
- Gas purity certification.
- Detecting trace benzene in ambient air.
- Detecting atmospheric pollutants.

Operational Theory

2.1 Introduction

The GC-Pro TCD Analyzer uses a Thermal Conductivity (TC) Detector and a Gas Chromatograph (GC) Column to separate and analyze different fractions of a volatile hydrocarbon sample. Using a carrier gas and a microprocessor actuated switching valve, a fixed volume of sample is pushed into the column maintained at a constant temperature. The eluted gas is analyzed for the specific components configured for your application using the TC detector and the column is back flushed to accept the fresh sample for the next cycle. Actual separating and detecting sequence may vary depending on compounds of interest in the application for which the analyzer is configured.

The GC-Pro TCD Analyzer uses the thermal conductivity detector to sense a variety of components that are separated through a column and eluted to the sensor in a time sequence determined by their respective retention time. It compares the difference in conductivity between a known volume of injected sample driven by carrier gas at a fixed temperature to a constant flowing reference gas. Thermal conductivity is a fast, accurate and reproducible tool for detection and measurement under certain conditions. In general, thermal conductivity measurements are binary and non-specific in nature, that is, they respond to the total difference in thermal conductivity between two samples. If the sample contains more than two components, the thermal conductivity measurement is ill defined and cannot be used to determine the concentration of the mixture without extensive calibration. Similarly, if the thermal conductivity difference between components of a binary mixture is low, sensitivity is negatively impacted.

The GC-Pro TC Analyzer avoids these issues by coupling the TC detector with a gas separation capability in the GC column. Therefore, even if the sample stream contains more than one compound, at any time during analysis only a binary mixture which includes the component of interest based on its separation properties, plus carrier gas is delivered to the detector. A suitable carrier gas can be selected that among other properties, maximizes the thermal conductivity difference for enhanced

sensitivity. And since the sampling valve is designed to inject a precise and known volume of sample at a fixed temperature, the actual concentration of the compound of interest can be determined.

A stainless steel packed column containing Chromosorb Diatomite or other material depending on the application, is held at a constant temperature. The temperature as well as the carrier gas and its pressure are critical and depend on the application. The actual temperature setpoint and compound separation for your instrument have been determined at the factory. They are listed in the *Addendum and Testing Results* section of Appendix C.

Using a specific carrier gas to inject the sample gas into a known in volume, the specific component of interest elutes from the column within a few minutes. The exact timing is characteristic of the material and has been determined at the factory during testing. Additionally, a clear separation is observed from other components in the sample gas however each has a characteristic timing so the instrument can select only the peak associated with the compound of interest for processing. All necessary information regarding carrier gas type, sample loop volume, temperature and pressure settings, and internal timing settings are given in the *Addendum and Testing Results* section of Appendix C.

2.2 Modes of Operation

The analyzer has 2 modes of operation depending on the position of the GC Sampling Valve (See Piping Diagram in Figure 2-2). They are: Sample Mode (position A) and Analysis Mode (position B).

1. Valve Position A—**Sampling Mode**

In this mode the analyzer configures the operational valve to back flush the column and charge the sample loop. The Sample Mode is programmed to continue for a 7 minute period by factory default; however, it is usually modified to match the needs of a particular process. The specific timing interval for your system is listed in the *Addendum and Testing Results* section of Appendix C. It is possible to set the Sample Mode duration up to 25 minutes.

2. Valve Position B—**Analysis Mode**

In this mode the analyzer configures the sampling valve to feed the gas in the sample loop through the column and to the detector. The eluted sample from the column is fed to the TC



detector for the analysis of the compound of interest in the stream. If configured to do so, the analyzer may read the detector for a programmed 5 second period at some point within this mode cycle to obtain a baseline reading for further calculation. This mode is usually programmed to continue until the compound of interest is fully eluted from the column. It is possible to set it up to 25 minutes.

During the Analysis Mode, a 'Peak Detect' period is programmed at which time the analyzer reads the detector output. The analyzer integrates the peak area during this time in conjunction with the baseline settings to calculate the concentration of the compound of interest. The calculation is performed at the end of the 'Peak Detector' period and the result is displayed at the end of Analysis Mode.

2.3 Analyzer Subsystems

The Model Analyzer is composed of four subsystems:

1. Sample System
2. GC Column
3. Detector Cell
4. Electronic Signal Processing, Display and Control

2.3.1 Sample System

All components used to control the sample and supporting gases are located on the front panel or inside the analyzer chassis. For the internal components, they are accessible after removing the top cover of the analyzer. Adjustments are made to the carrier gas pressure and sample flow using the controls on the front panel. See Figure 1-1. Other adjustments are made using the touch screen and are described in Section 4.

The analyzer contains three separate isothermal chambers 'SAMPLE', 'Sensor', and 'COLUMN' that are controlled individually. Temperature and control information are available onscreen. See Section 4.5.7. The chambers and the switching valve are identified in Figure 2-1.

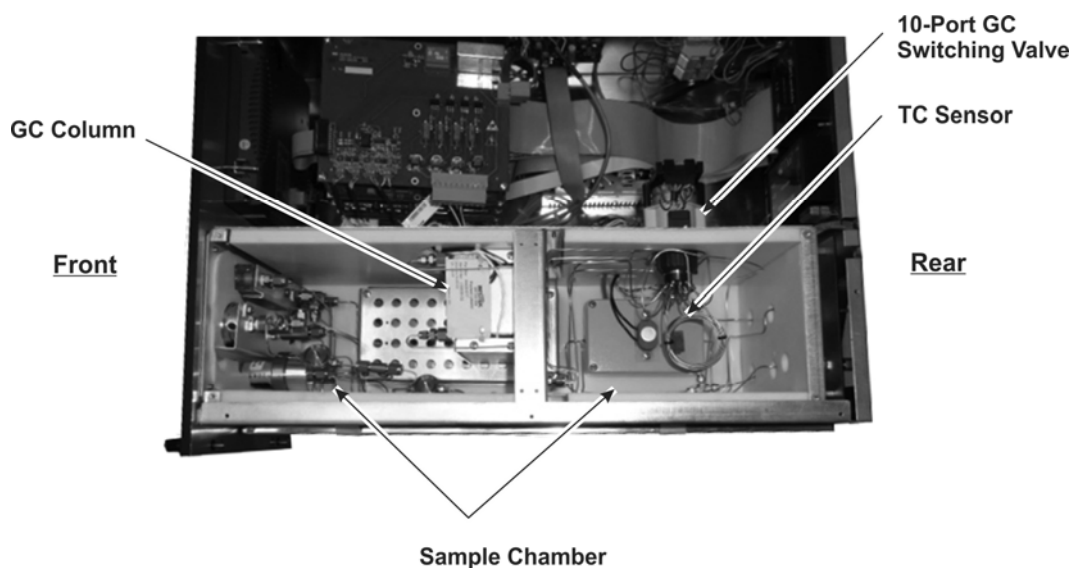

Figure 2-1: Internal Temperature Controllers

The sample chamber contains the 10-port GC switching valve and 2 sample loops. The 'TC Sensor' chamber contains the thermal conductivity sensor. The 'COLUMN' is housed in a separate 'COLUMN' enclosure and maintained at a temperature of 70° C. Chamber temperatures have been set at the factory however they can be changed by the user from the Settings/Thermocouple/Settings screen as described in Section 4.5.7.2. The actual temperature setpoint for your instrument may be different depending on the application. It is listed in the *Addendum and Testing Results* section of Appendix C.

2.3.2 Gas Flow Control System

The analyzer is equipped with ports for the introduction of carrier gas, span, and sample gas. Depending on the application and the options chosen, some instruments may have a separate port for admitting a purge gas.

It is imperative that the sample, carrier and span gases be supplied at constant pressure using two stage stainless steel diaphragm gas regulators. The recommended pressure range is 30 to 80 psig for sample and carrier gas; the span gas should be supplied at a pressure of 20 psig

to the restrictor fitting either on the optional auto calibration module or the span inlet on the rear panel.

The Piping Diagram for the standard instrument is shown in Figure 2-2. A 10-port 2-position GC sampling valve is used to control and direct gas flows including sampling, back flush, and carrier gas. The fixed volume sample loop ensures the same volume of sample injection in the column every cycle.

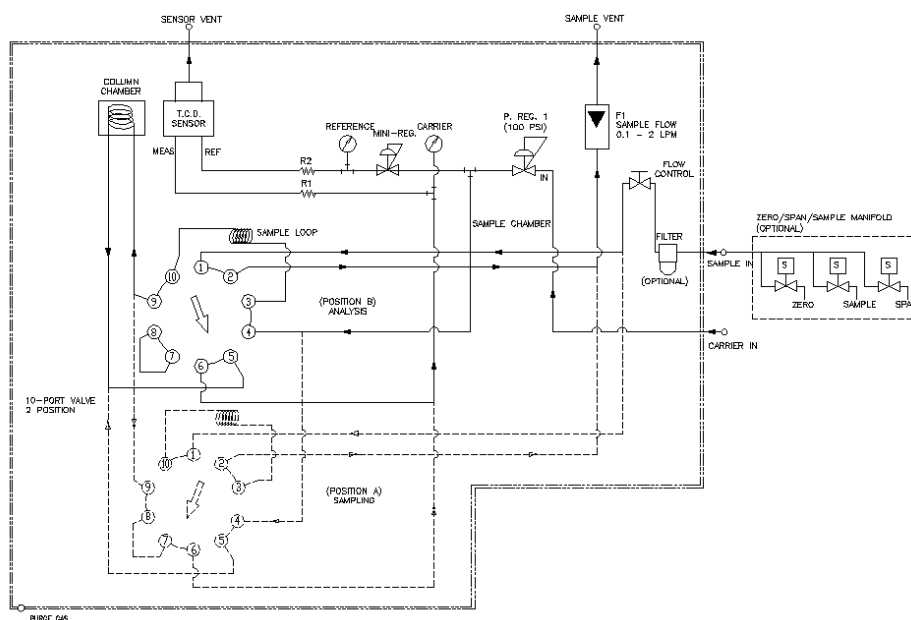

Figure 2-2: Typical Piping Diagram Used in the GC-Pro TCD

If your instrument is fitted with the optional auto calibration module, a separate compartment containing a pair of solenoid valves is installed for controlling the introduction of sample or span gas to the detector. Calibration can be performed automatically on a programmed schedule or manually using the front panel interface.

Other detector options are available for the GC-Pro series instrument which may alter the appearance of the front and rear panels and include additional gas ports such as fuel and air for the FID option. These options, if included, will be described in an accompanying addendum to this manual.

2.3.3 Gas Separation System

The carrier gas pressure and column temperature are the critical parameters in the separation process. A heater is used in column housing and the temperature controlled by the Temperature PCB. A constant carrier gas flow is provided by a pressure regulator on the front panel set to a specific pressure with an inlet carrier gas supply of 80 psig at the rear panel. Thus, a stable flow is achieved by maintaining a constant pressure across restrictors upstream from the cell. Actual carrier gas flow rate through the column, which is crucial for separation retention time, will depend on the carrier gas pressure and the type of column used for each application. It is important that all temperature and pressure settings are set to the values listed in the *Addendum and Testing Results* section of Appendix C.

2.4 Detector Cell

The thermal conductivity sensor contains two chambers, one for the reference gas of known conductivity (which is of the same as the carrier gas) and one for the sample gas which is driven by the carrier gas. Each chamber contains a pair of heated filaments. Depending on its thermal conductivity, each of the gases conducts a quantity of heat away from the filaments in its chamber. See Figure 2-3(a).

The resistance of the filaments depends on their temperature. These filaments are parts of the two legs of a bridge circuit that unbalances if the resistances of its two legs do not match. See Figure 2-1(b).

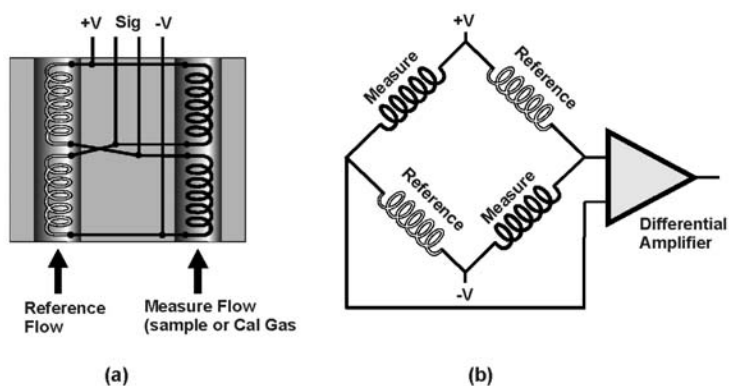

Figure 2-3: Thermal Conductivity Cell Operating Principle

Installation

Installation of the GC-Pro TCD Analyzer includes:

1. Unpacking
2. Mounting
3. Gas connections
4. Electrical connections
5. Testing the system.

3.1 Unpacking the Analyzer

Although the analyzer is shipped with all the materials you need to install and prepare the system for operation. Carefully unpack the analyzer and inspect it for damage. Immediately report any damage or shortages to the shipping agent.

3.2 Mounting the Analyzer

The GC-Pro TCD analyzer is a general-purpose analyzer and as such is designed with (non-sealed) enclosures. It must be installed in an area where the ambient temperature is not permitted to drop below 32°F or rise above 100°F. In areas outside these temperatures, auxiliary heating/cooling must be supplied. The enclosure is oil and dust resistant and although it is designed to resist moisture, it should NOT be considered completely watertight. Mounting must be made securely. Avoid locations that are subject to extreme vibration and sway.

Sufficient space must be provided around and above the analyzer to accommodate the necessary electrical conduit and plumbing connections and top cover removal. The top cover must be allowed to be lifted off for possible service access to all components within the enclosure. Refer to the system/analyzer outline drawings for dimensions.

Regardless of configuration, the analyzer/system must be installed on a level surface with sufficient space allocated on either side for

personnel and test equipment access. Subject to the foregoing, the analyzer should be placed as close to the sample point as is possible.

All pertinent dimensions, connecting points, and piping details can be found in the drawings section as part of the outline, input-output, and piping diagrams. These drawings are specific to the instrument or system to which the manual applies.

3.3 User Connections

All user connections are made on the rear panel. Consult the input-output and outline diagrams in the drawing section of the manual. Not all the features displayed may be present in your system. Optional features when installed may change the appearance of the front and rear panels as well as add details to some display screens. Refer to any Addenda for additional information that may apply to your instrument.

3.3.1 Electrical Power Connections

The standard analyzer requires a supply of 100-125VAC, single-phase power. Power connections are made at the rear panel of the unit. Refer to the input-output diagram for more information. The electrical power service must include a high-quality ground wire. A high-quality ground wire is a wire that has zero potential difference when measured to the power line neutral. If you have the 220 VAC option, you will require 220 or 240 VAC, 50/60 Hz power. Check the analyzer input-output diagram, power schematic, outline, and wiring diagrams for incoming power specifications and connecting points.

CAUTION: PRIMARY POWER TO THE SYSTEM SHOULD NOT BE SUPPLIED UNTIL ALL CUSTOMERS WIRING IS INSPECTED PROPERLY BY START-UP PERSONNEL.



3.3.2 Electronic Connections

Figure 3-1 shows the GC-Pro TCD rear panel. There are connections for power, digital communications, and both digital and analog concentration output.

For safe connections, no uninsulated wiring should be able to come in contact with fingers, tools or clothing during normal operation.

CAUTION:

USE SHIELDED CABLES. ALSO, USE PLUGS THAT PROVIDE EXCELLENT EMI/RFI PROTECTION. THE PLUG CASE MUST BE CONNECTED TO THE CABLE SHIELD, AND IT MUST BE TIGHTLY FASTENED TO THE ANALYZER WITH ITS FASTENING SCREWS. ULTIMATELY, IT IS THE INSTALLER WHO ENSURES THAT THE CONNECTIONS PROVIDE ADEQUATE EMI/RFI SHIELDING.

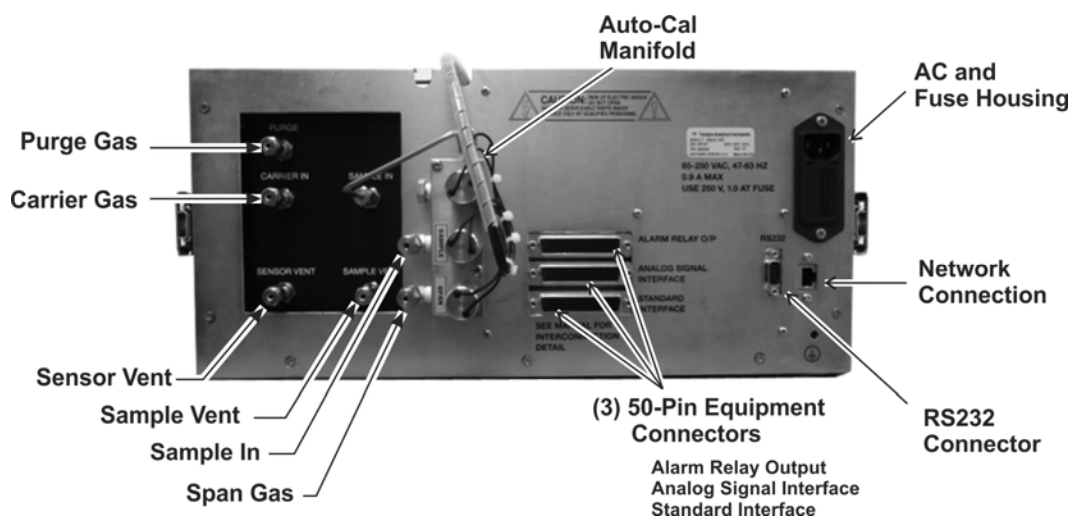

Figure 3-1: GC-Pro TCD Rear Panel with Optional Gas Manifold

3.3.2.1 PRIMARY INPUT POWER

The power cord receptacle and fuse block are located in the same assembly. Insert the power cord into the power cord receptacle.

CAUTION:

POWER IS APPLIED TO THE INSTRUMENT'S CIRCUITRY AS LONG AS THE INSTRUMENT IS CONNECTED TO THE POWER SOURCE.

The standard power supply requires 110 VAC, 50/60 Hz or 220 VAC, 50/60 Hz (optional) power.

3.3.2.2 FUSE INSTALLATION

The fuse block, at the right of the power cord receptacle, accepts US or European size fuses. A jumper replaces the fuse in whichever fuse receptacle is not used.

3.3.2.3 50-PIN EQUIPMENT INTERFACE CONNECTOR

There are three 50-pin Equipment Interface Connectors installed on the rear panel of the GC-Pro TCD. Figure 3-2 shows the pin layout of the Equipment Interface connectors. The arrangement is shown as seen when the viewer faces the rear panel of the analyzer. The pin numbers for each input/output function are given where each function is described in the paragraphs below.

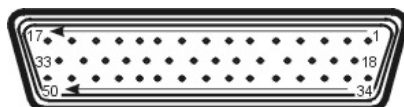

Figure 3-2: Equipment Interface Connector Pin Arrangement

From top to bottom the signals handled by the individual connectors are as follows:

- Top connector: Alarm relay connections
- Middle connector: Analog output signals
- Bottom connector: Standard connector for all additional signals

See Section 3.3.2.9 for Pin-Out connections for each connector.

3.3.2.4 ANALOG OUTPUT

There are four DC output signal pins—two pins per output. These are found on the middle connector. For polarity, see Table 3-1. The outputs are:

- 0–1 VDC % of Range: Voltage rises linearly with increasing concentration, from 0 V at 0 concentration to 1 V at full scale. (Full scale = 100% of programmable range.)

0–1 VDC Range ID:	0.20 V = Low Range 0.5 V = Medium Range 0.80 V = High Range
4–20 mA DC % Range:	Current increases linearly with concentration, from 4 mA at 0 concentration to 20 mA at full scale. (Full scale = 100% of programmable range.)
4–20 mA dc Range ID:	6.8 mA = Range 1 12.0 mA = Range 2 16.8 mA = Range 3

Table 3-1: Analog Output Connections — Middle Connector

Pin	Function
3	Channel 2, + 4-20 mA, floating
4	Channel 2, – 4-20 mA, floating
5	Channel 1, + 4-20 mA, floating
6	Channel 1, – 4-20 mA, floating
8	Channel 2, 0-1 VDC
23	Channel 2, 0-1 VDC, negative ground
24	Channel 1, 0-1 VDC
7	Channel 1, negative ground

Examples:

The analog output signal has a voltage which depends on gas concentration relative to the full scale of the range. To relate the signal output to the actual concentration, it is necessary to know what range the instrument is currently on, especially when the analyzer is in the auto ranging mode.

The signal output for concentration is linear over the currently selected analysis range. For example, if the analyzer is set on a range that was defined as 90-100% nitrogen then the output would be as shown in Table 3-2.

Table 3-2: Analog Concentration Output—Example

% Nitrogen	Voltage Signal Output (VDC)	Current Signal Output (mA DC)
90	0.0	4.0
91	0.1	5.6
92	0.2	7.2
93	0.3	8.8
94	0.4	10.4
95	0.5	12.0
96	0.6	13.6
94	0.7	15.2
98	0.8	16.8
99	0.9	18.4
100	1.0	20.0

3.3.2.5 ALARM RELAYS

The nine alarm-circuit connector pins connect to the internal alarm relay contacts. The pins for the alarm relays are available from the top interface connector. Each set of three pins provides one set of Form C relay contacts. Each relay has both normally open and normally closed contact connections. The contact connections are shown in Table 3-3. They are capable of switching up to 3 amperes at 250 VAC into a resistive load. The connectors are:

Threshold Alarm 1:

- Can be configured as high (actuates when concentration is above threshold), or low (actuates when concentration is below threshold).
- Can be configured as failsafe or non-failsafe
- Can be configured as non-latching
- Can be configured out (defeated).

Threshold Alarm 2:

- Can be configured as high (actuates when concentration is above threshold), or low (actuates when concentration is below threshold).
- Can be configured as failsafe or non-failsafe
- Can be configured as non-latching
- Can be configured out (defeated).

System Alarm:

- Actuates when DC power supplied to circuits is unacceptable in one or more parameters. Permanently configured as failsafe and latching. Cannot be defeated.

Note: Reset by pressing the STANDBY button to remove power. Then press STANDBY again and any other button except SYSTEM to resume. Further detail can be found in Chapter 4, Section 4.5.4.

Table 3-3: Alarm Relay Contact Pins — Top Connector

Pin	Contact
45	Threshold Alarm 1, normally closed contact
28	Threshold Alarm 1, moving contact
46	Threshold Alarm 1, normally open contact
42	Threshold Alarm 2, normally closed contact
44	Threshold Alarm 2, moving contact
43	Threshold Alarm 2, normally open contact
36	System Alarm, normally closed contact
20	System Alarm, moving contact
37	System Alarm, normally open contact

3.3.2.6 DIGITAL REMOTE CAL INPUTS

The digital remote calibration signals are available on the bottom connector. They input accepts 0 V (off) or 24 VDC (on) for remote control of calibration. (See *Remote Calibration Protocol* below.) See Table 3-4 for pin connections.

Span: Floating input. A 5–24 V input across the + and – pins puts the analyzer into the *Span* mode. If cycle mode is ‘Continuous’. Either side may be grounded at the source of the signal. A 0–1 volt across the terminals allows *Span* mode to terminate when done. A synchronous signal must open and close external span valve appropriately.

Cal Contact: This relay contact is closed while analyzer is spanning. (See *Remote Calibration Protocol* below.)

Table 3-4: *Remote Calibration Connections — Bottom Connector*

Pin	Function
10	+ Remote Span
12	– Remote Span
40	Cal Contact
41	Cal Contact

Remote Calibration Protocol: To properly time the Digital Remote Cal Inputs to the GC-Pro TCD Analyzer, the customer's controller must monitor the Cal Relay Contact.

When the contact is OPEN, the analyzer is analyzing, the Remote Cal Inputs are being polled, and a span command can be sent.

When the contact is CLOSED, the analyzer is already calibrating. It will ignore your request to calibrate, and it will not remember that request.

Once a span command is sent, and acknowledged (contact closes), release it. If the command is continued until after the span is complete, the calibration will repeat and the Cal Relay Contact (CRC) will close again.

For example:



1. Test the CRC. When the CRC is open, send a span command until the CRC closes (The CRC will quickly close.)
2. When the CRC closes, remove the span command.

When CRC opens again, the span calibration is done, and the sample is being analyzed.

3.3.2.7 'MEASURE ONCE' (OR ONE SHOT MEASUREMENT) CONTACTS

There are three dedicated relay contacts and these are available from the bottom Equipment Interface Connector. They are assigned to indicate status of 'measure once' (or one shot measurement). Contacts are normally open, and they close when GC-Pro TCD switches to that particular range.

Table 3-5: 'Measure Once' Relay Connections

Pin	Function
9	+ Start Measurement Digital Input
11	- Start Measurement Digital Input
21	IDLE Contact 1
38	IDLE Contact 2
22	IN MEASUREMENT Contact 1
39	IN MEASUREMENT Contact 2
19	MEASUREMENT DONE Contact 1
18	MEASUREMENT DONE Contact 2

The MEASUREMENT DONE contact only closes for 5 seconds at end of the measurement cycle. After that, the IDLE contact closes. The display reading and analog output will then remain fixed until a new measurement is requested.

Digital input range is 5 to 24 vdc to start measurement.

3.3.2.9 PIN OUT TABLE

The following table summarizes all the outputs/inputs available on the three 50 pin D-Sub connectors on the back panel of the analyzer.

Table 3-6: Pin out of Alarm Relay O/P (Top) 50 pin D-Sub Connector

pin #	Description	pin #	Description
1	Alarm Relay # 9, NC contact	26	Alarm Relay # 17, C contact
2	Alarm Relay # 9, C contact	27	Alarm Relay # 17, NO contact
3	Alarm Relay # 9, NO contact	28	Alarm Relay # 18, NC contact
4	Alarm Relay # 10, NC contact	29	Alarm Relay # 18, C contact
5	Alarm Relay # 10, C contact	30	Alarm Relay # 18, NO contact
6	Alarm Relay # 10, NO contact	31	+15 VDC
7	Alarm Relay # 11, NC contact	32	Analog Ground
8	Alarm Relay # 11, C contact	33	+15 VDC
9	Alarm Relay # 11, NO contact	34	Analog Ground
10	Alarm Relay # 12, NC contact	35	+15 VDC
11	Alarm Relay # 12, C contact	36	Ch. # 1, 4-20 madc input, HOT
12	Alarm Relay # 12, NO contact	37	Analog Ground
13	Alarm Relay # 13, NC contact	38	+15 VDC
14	Alarm Relay # 13, C contact	39	Ch. # 2, 4-20 madc input, HOT
15	Alarm Relay # 13, NO contact	40	Analog Ground
16	Alarm Relay # 14, NC contact	41	+15 VDC
17	Alarm Relay # 14, C contact	42	Ch. # 3, 4-20 madc input, HOT
18	Alarm Relay # 14, NO contact	43	Analog Ground
19	Alarm Relay # 15, NC contact	44	+15 VDC
20	Alarm Relay # 15, C contact	45	Ch. # 4, 4-20 madc input, HOT
21	Alarm Relay # 15, NO contact	46	Analog Ground
22	Alarm Relay # 16, NC contact	47	Ch. # 5, 4-20 madc input, HOT
23	Alarm Relay # 16, C contact	48	Ch. # 6, 4-20 madc input, HOT
24	Alarm Relay # 16, NO contact	49	+15 VDC
25	Alarm Relay # 17, NC contact	50	Spare Analog Input

Table 3-7: Pin out of Analog Signal (Middle) 50 pin D-Sub Connector

pin #	Description	pin #	Description
1	4-20 ma Out, Ch. # 3- HOT	26	0-1 vdc Out, Ch. # 8 - HOT
2	4-20 ma Out, Ch. # 3- RET	27	Analog Ground
3	4-20 ma Out, Ch. # 4- HOT	28	0-1 vdc Out, Ch. # 9 - HOT
4	4-20 ma Out, Ch. # 4- RET	29	0-1 vdc Out, Ch. # 10 - HOT
5	4-20 ma Out, Ch. # 5- HOT	30	Analog Ground
6	4-20 ma Out, Ch. # 5- RET	31	O2 sensor Hot Input #2 (NI)
7	4-20 ma Out, Ch. # 6- HOT	32	O2 sensor Return Input #2 (NI)
8	4-20 ma Out, Ch. # 6- RET	33	Thermistor for O2 sensor #2 ((NI)
9	4-20 ma Out, Ch. # 7- HOT	34	Thermistor for O2 sensor #2 (NI)

pin #	Description	pin #	Description
10	4-20 ma Out, Ch. # 7- RET	35	O2 sensor Hot Input #3 (NI)
11	4-20 ma Out, Ch. # 8- HOT	36	O2 sensor Return Input #3(NI)
12	4-20 ma Out, Ch. # 8- RET	37	Thermistor for O2 sensor #3 (NI)
13	4-20 ma Out, Ch. # 9- HOT	38	Thermistor for O2 sensor #3 (NI)
14	4-20 ma Out, Ch. # 9- RET	39	O2 sensor Hot Input #4 (NI)
15	4-20 ma Out, Ch. # 10- HOT	40	O2 sensor Return Input #4 (NI)
16	4-20 ma Out, Ch. # 10- RET	41	Thermistor for O2 sensor #4 (NI)
17	Analog Ground	42	Thermistor for O2 sensor #4 (NI)
18	Analog Ground	43	O2 sensor Hot Input #5 (NI)
19	0-1 vdc Out, Ch. # 3 - HOT	44	O2 sensor Return Input #5 (NI)
20	0-1 vdc Out, Ch. # 4 - HOT	45	Thermistor for O2 sensor #5 (NI)
21	Analog Ground	46	Thermistor for O2 sensor #5 (NI)
22	0-1 vdc Out, Ch. # 5 - HOT	47	O2 sensor Hot Input #6 (NI)
23	0-1 vdc Out, Ch. # 6 - HOT	48	O2 sensor Return Input #6 (NI)
24	Analog Ground	49	Thermistor for O2 sensor #6 (NI)
25	0-1 vdc Out, Ch. # 7 - HOT	50	Thermistor for O2 sensor #6 (NI)

(NI) = Not Implemented

Table 3-8: Pin out of Standard (Bottom) 50 pin D-Sub Connectors

pin #	Description	pin #	Description
1		26	
2		27	
3	+ Output 4-20 ma - Channel 2	28	Alarm 1 C Contact
4	- Output 4-20 ma - Channel 2	29	
5	+ Output 4-20 ma – Channel 1	30	
6	- Output 4-20 ma – Channel 1	31	
7	- Output 0-1 v (Channel 1)	32	Exhaust Solenoid Hot
8	+ Output 0-1 v (Channel 2)	33	Sample Solenoid Hot
9	+ Start one shot input	34	Range 4 Contact/ not used
10	Remote Span +	35	Range 4 Contact/not used
11	- Start one shot input	36	Alarm 3 NC Contact
12	Remote Span –	37	Alarm 3 NO Contact
13		38	IDLE Contact 2 (one shot only)
14			MEASUREMENT Contact 2 (one shot only)
15		39	
16	Span Solenoid Return	40	Calibration Contact
17	Span Solenoid Hot	41	Calibration Contact
18	DONE Contact 1 (one shot only)	42	Alarm 2 NC Contact
19	DONE Contact 2 (one shot only)	43	Alarm 2 NO Contact
		44	Alarm 2 C Contact

pin #	Description	pin #	Description
20	Alarm 3 C Contact	45	Alarm 1 NC Contact
21	IDLE Contact 1 (one shot only)	46	Alarm 1 NO Contact
22	MEASUREMENT Contact 1 (one shot only)	47	
23	- Output 0-1 v (Channel 2)	48	Exhaust Solenoid Return
24	+ Output 0-1 v (Channel 1)	49	
25		50	Sample Solenoid Return

3.3.2.10 RS-232 PORT

The digital signal output is a standard RS-232 serial communications port used to connect the analyzer to a computer, terminal, or other digital device. It requires a standard 9-pin D connector.

Input: The input functions using RS-232 that have been implemented to date are described in Table 3-7.

Table 3-9: Commands via RS-232 Input

Command	Description
AS <enter>	Auto Span immediately (continuous mode)
SV <enter>	Switch to Span Valve
ZV <enter>	Switch to Zero Valve
AV <enter>	Switch to Analyze Valve
C1 <enter>	If in 1Shot mode, start a cycle
C2 <enter>	If in 1Shot mode, start a span cycle
PMA <enter>	Switch to standard message
PMB <enter>	Switch to TCD output mode
PMC <enter>	Switch to Query Mode (used for interface with OPC server)

Implementation: The RS-232 protocol allows some flexibility in its implementation. Table 3-8 lists certain RS-232 values that are required by the Standard Mode GC-Pro TCD implementation.

Table 3-10: Required RS-232 Options

Parameter	Setting
Baud	9600
Byte	8 bits

Parity	none
Stop Bits	1
Message Interval	Sent at the end of each cycle.

3.3.3 Gas Connections

The analyzer gas connection diagram identifies the various gas connection points as to function and location. Figure 3-1 shows the gas connection points for instruments fitted with the optional auto calibration module.

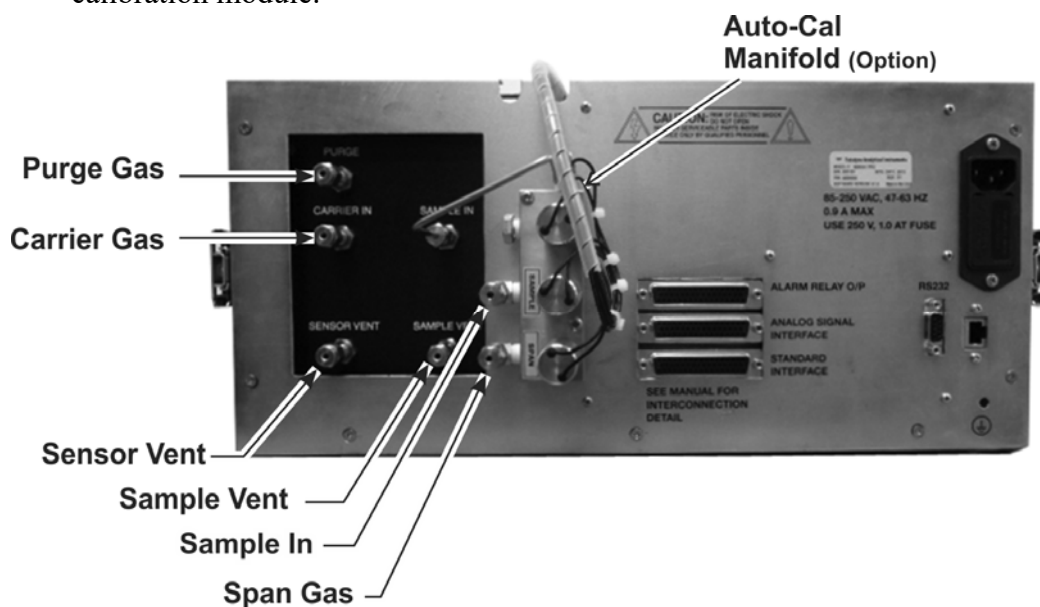

Figure 3-3: Gas Connections

Gas connections to the instrument are made at the 1/8" or 1/4" stainless steel tube fittings provided on the rear panel. Note that the optional purge and sensor vent fittings are 1/4" while all other gas connections are 1/8".

Before tubing is connected to the system, it must be decontaminated to eliminate any hydrocarbon deposits. Using a small torch, heat each length of tubing while passing nitrogen through it until it glows red. Begin at the nitrogen source end and proceed down the length of the

tube, “chasing” the red glow (and hydrocarbon deposits) down to the open end of the tube. Cap the tubing while not in use with suitable non-contaminating caps.

All sample, calibration, and supporting gas lines, which deliver gas to the analyzer, must be decontaminated before connection; vent lines do not.

When connecting the various gas lines to the system, be absolutely certain that no “dead ends” are left; that is, no unused branch lines should be left capped off, where pockets might form of material that is not representative of the current contents of the line, or which might keep contaminants from being purged out of the system.

CAUTION: **THE GASES USED MUST BE OF THE HIGHEST QUALITY, ULTRA ZERO GRADES, AS SHOWN BELOW. FAILURE TO DO SO WILL RESULT IN CONTAMINATION AND FAILURE TO DETECT AT THE REQUIRED ACCURACY.**



Normally, two supporting gases (carrier gas and span gas) will be required to operate the analyzer. The recommended composition for the span gas is specified Appendix C: Addendum and Testing Results. Zero calibration is handled electronically and does not require a separate gas source. The support gases should be supplied from cylinders that are equipped with an appropriate type of regulator.

CAUTION: **UNDER NO CIRCUMSTANCES SHOULD YOU EMPLOY A REGULATOR THAT IS NOT EQUIPPED WITH A METALLIC DIAPHRAGM ANYWHERE IN THE SYSTEM.**



The regulators should be inspected prior to installation to be sure that they are oil-free. Failure to comply with these directives will result in a constant drift in analyzer output, as organic compounds will outgas into the plumbing system at a rate that is related to the ambient temperature. Use 316 stainless steel, dual-stage stainless steel diaphragm regulators; shutoff valves should be used downstream from each regulator.

Place the supply cylinders as close to the analyzer as possible, and connect to the analyzer with new tubing. Be sure that all plumbing connections are free of leaks.

Note: Use only stainless steel tubing throughout the system.

Consult the assembly, piping, outline drawings, and any Addenda included with this manual to determine if special conditions apply.

3.3.3.1 EFFLUENT

All the gases introduced into the detection cell vent from one fitting at the rear of the analyzer. TAI recommends that the cell be permitted to vent directly to the atmosphere wherever possible.

If optional features such as an FID detector are installed, a vent line is required. With this option the installation must include a drop-out pot to collect the water that is formed by the burning of the hydrogen or other fuel.

Any vent line must be constructed so that water and dirt cannot collect in it.

3.3.3.2 SENSOR VENT

The sensor vents through a separate vent at atmospheric pressure. This vent may contain water and so any connection made to the port must slope downwards for proper liquid removal. Never allow the vent to clog or fill with liquid. It must be free-flowing and be without kinks or obstructions.

3.3.3.3 CARRIER GAS CONNECTION

The carrier gas supply is also used as the reference gas for the TC sensor. The specific gas used is application dependant and is listed in the *Addendum and Testing Results* section of Appendix C.

The carrier gas should be supplied at 80 psig. Make the carrier/reference gas connection according to the gas connection diagram included at the back of this manual.

3.3.4 Sample and Span Gas Connections

The sample and span gas connections are made at the rear panel. If the optional auto calibration module is installed, the sample and span gas will connect to this module. If no auto calibration module is present, these gases connect to the labeled fittings on the rear panel.

Set the supply pressure for sample and span gas to 20 psig.

3.4 Placing the System in Operation

See Section 4 for information on starting the analyzer for the first time. Make sure that all electrical connections have been made correctly and all connectors are fully seated. Make sure all gas connections are correct and leak-free.

Operation

This section of the manual describes how to setup and operate the GC-Pro TCD Analyzer. It includes preliminary steps and equipment needed for operation, initial startup, and then the actual operation of the analyzer using the touch screen interface is described. You should read this chapter in its entirety and become familiar with the operating characteristics of this system before starting the analyzer for the first time. The *Addendum and Testing Results* section of Appendix C lists the software revision and default settings for your specific analyzer.

The GC-Pro TCD Analyzer incorporates a Human/Machine Interface (HMI) that uses a touch-sensitive LCD display with menus logically grouped for easy, intuitive access to all functions. The features supported by the newly designed system HMI interface include:

1. Sensor data acquisition, data logging and system health monitoring performed through the touch-screen display.
2. Firmware up-grades of the 89C5131 PCB can be carried out through an internal USB 2.0 interface
3. Firmware up-grade for the 9261 controller board can be carried out through the USB 2.0 interface using the SAMBA tool.
4. Stand alone testing of the 89C5131 PCB can be performed through the debug hyper terminal (9600Kbps) connection on the rear panel.

Operation of the analyzer including setup functions are performed from the touch screen. The HOME screen is the main display screen and the MENU screen allows the user to enter any phase of operation, calibration, and setup simply by touching the specific on-screen button. See Section 4.5 and following sections.

4.1 Equipment

The following supporting gases and hardware will be required to operate the (standard) analyzer:

1. **Carrier Gas:** A cylinder of nitrogen gas, zero gas quality, equipped with dual stage metallic diaphragm regulator is required.
2. **Span Gas:** A cylinder or a permeation device system, capable of generating known concentration of the species of interest will be required to standardize the analyzer.
3. **Sample Pressure Regulation:** An oil-free, metallic diaphragm regulator must be installed at the sample point when possible; see Section 3.3.3 *Gas Connections*.

Note: Depending on the installed options other support gases may be required. If so equipped, an addendum to this manual will be included that describes the required gases, hardware, setup and operational details.

CAUTION: THE GASES USED MUST BE OF THE HIGHEST QUALITY, ULTRA ZERO GRADES, AS SHOWN BELOW. FAILURE TO DO SO WILL RESULT IN CONTAMINATION AND FAILURE TO DETECT AT THE REQUIRED ACCURACY.



CARRIER GAS: NITROGEN GAS, ULTRA ZERO GRADE WITH THC LESS THAN 0.05 PPM.

4.2 Preliminary Power-Off Check List

Make the following checks of the installation before proceeding further into the start-up procedure:

1. Check to see that the sample and supporting gas installation is in accordance with the specifications called for in the installation and application sections of the manual (Chapter 3). Be sure that the supporting gases are of the proper composition and are connected to the correct fittings at the rear of the analyzer.

2. Check to see that the electrical installation conforms to the instructions contained in the installation section (Chapter 3) and on the input-output diagram.
3. Remove the top cover and check to see that the printed circuit boards and cables are firmly seated in their respective sockets.
4. Confirm that recorder and alarm connections are properly made.

4.3 Powering Up the Unit

Before applying power to the analyzer for the first time perform the following checks:

1. Make sure that the proper power 120/220 VAC 50/60 Hz is available.
2. Connect the AC power cord to the rear panel and then plug the other end into the mains supply. As soon as power is established, the unit will turn on.
3. Check that the Power, CPU, and COM LEDs illuminate and the Teledyne Logo screen appears on the display.



4. Momentarily, the Teledyne screen will be replaced with a second start-up screen that lists the Model, Serial Number, Software Version and other parameters specific to your instrument.

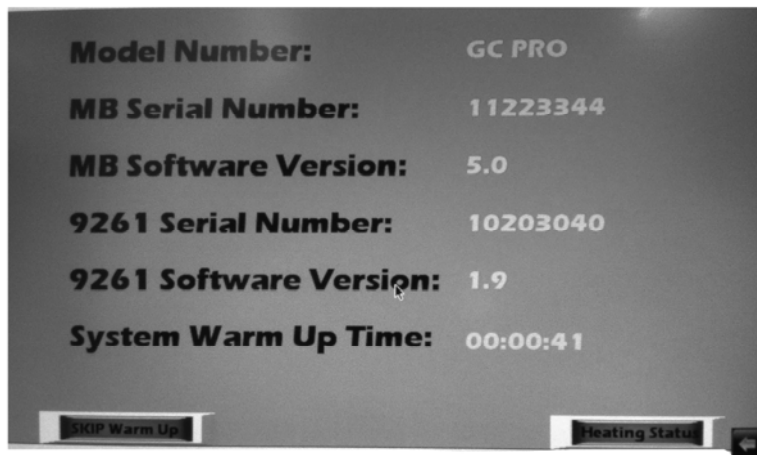

5. A 4-hour warm up time is required when the unit is cold. This allows sufficient time for the internal heaters to come up to the required temperature and stabilize. The screen will indicate a countdown as the warm up period progresses. If the unit is already warm, the warm up period may be 45 or 30 minutes depending on the internal temperatures.

The warm up time can be defeated (not recommended) by pressing the SKIP Warm Up button. In this case, the unit will bypass the warm up period and immediately enter the diagnostic phase as described below.

The user can check the internal temperature of the three heated chambers by pressing Heater Status button. This will bring up an information screen as shown below.

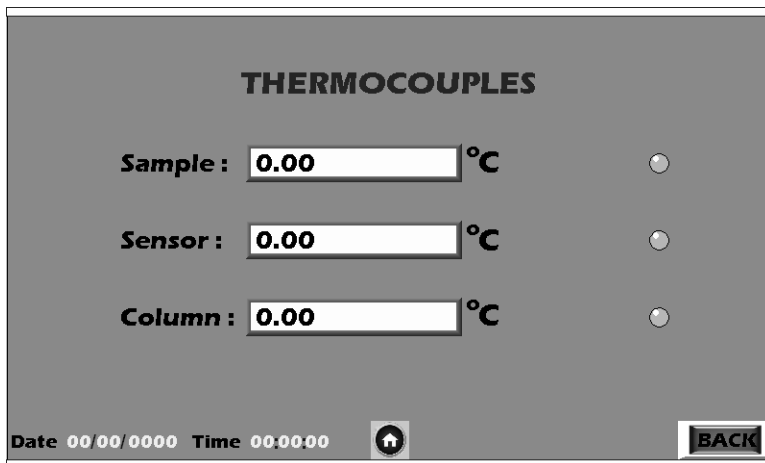

This screen provides the actual temperatures in the respective chambers. It is read-only, however once the unit has attained operating temperature and concluded the initial power up sequence, this screen can be used to alter the thermal parameters of the system. See Section 4.5.7.

6. During the warm up period activate the support gases as described in Section 4.4.
7. Following the warm up, the system will initiate a self-diagnostic routine and display the results as either “OK” or “Failed”

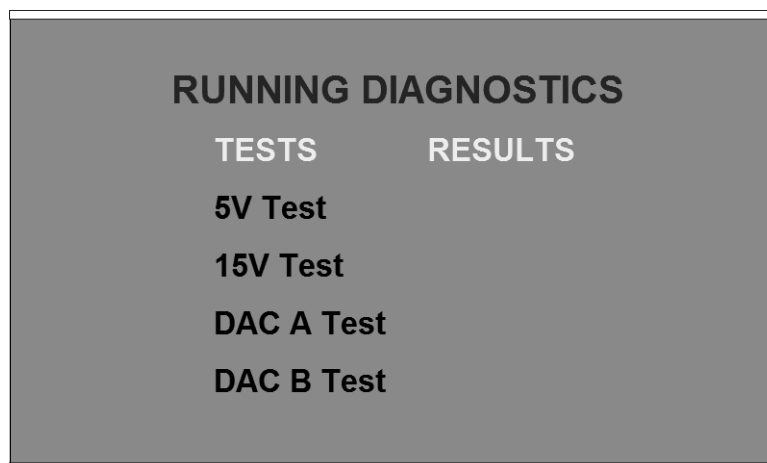

8. After the self diagnostic test has completed the instrument will enter the analyze mode and display the analyze screen. See Section 4.5.13.

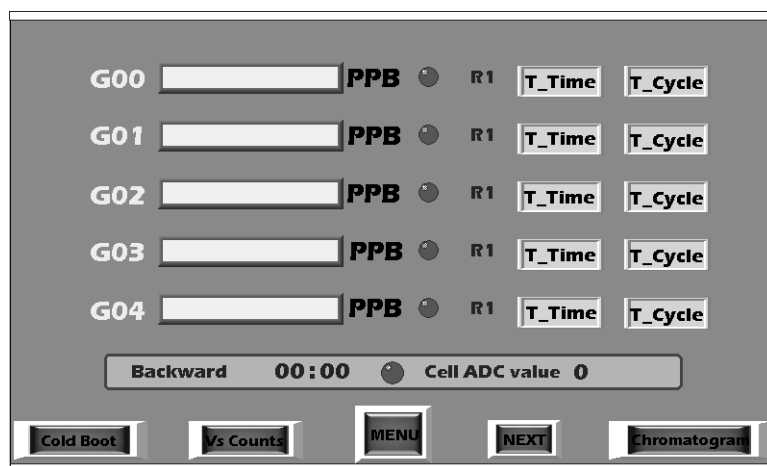

4.4 Activating the Support Gases

The instrument gas controls are located on the front panel adjacent to the touch screen display as shown in Figure 1-1. Make sure that the following support gases are available at the analyzer:

- Carrier gas: (usually nitrogen but refer to Appendix C for your specific application.
- Span gas: Typically 70-90% of measured component on the range of interest in a clean background gas. Refer to Appendix C for the specific span gas composition for your application.

4.4.1 Carrier Gas

Set the carrier gas source regulator to 80 psig and adjust the analyzer sample regulator until the sample pressure gauge reads the recommended sample pressure of 7.0 psig.

4.4.2 Span Gas

1. Feed span gas to the analyzer (see Section 4.4.2). Gas switching can be performed manually or handled through the auto calibration valves (if the option is added). See Section 4.5.10.3.
2. Observe that the analyzer sample flow meter reads from 0.3 to 1.0 SCFH.
3. Turn off span gas.

4.5 Analyzer Operation

Although the GC-Pro TCD has been programmed for your application at the factory, it can be further configured at the operator level. Depending on the specifics of the application, this might include all or a set of the following procedures:

1. Setting system parameters
 - Establish a security password, if desired, requiring operator to log in.
 - Establish and start an automatic calibration cycle (if equipped with the optional auto calibration module).
2. Routine operation.



- Calibrate the instrument.
 - Choose auto ranging or select a fixed range of analysis.
 - Set alarm setpoints and modes of alarm operation.
3. Special functions setup.
- Calibrate analog output, select analog output source, assign names for groups and peaks, etc..

Procedures for accessing and/or changing parameters as well as analyzer operation are detailed in the sections to follow. All functions can be accessed from the MENU screen which is accessible via the center button on the HOME screen.

The default screen is the HOME screen (see Section 4.5.2). This is the analysis display and shows details regarding the current sample being analyzed. However, the user can go directly to any function supported by the analyzer by pressing the MENU button. The only exception to this is when the instrument is powered up. It will go through a warm-up period, followed by a diagnostic self-test routine as explained in Section 4.3.

4.5.1 Default Parameters

The versatility of this analyzer usually results in significant changes being made to parameters over the course of time to better suit a particular application. Occasionally processes change requiring alteration to alarms, filter settings etc. At some time, it may be beneficial to reset the analyzer to the default conditions as it was when shipped from the factory. Below is a listing of the default parameters used in configuring the typical GC-Pro TCD instrument. Your specific application may require different settings. Refer to the *Addendum and Testing Results* section of Appendix C for any specific changes or recommendations that apply to your application.

Range/Application:	Refer to the <i>Addendum and Testing Results</i> section of Appendix C
Range:	Manual
Alarms:	Defeated, 20ppb, 50ppb, HI, NON-FAILSAFE, NON-LATCHING

Auto Span Timing: Defeated, every 7 days, at 12 hours

Span: 80 ppb

Password: 11111

4.5.2 The HOME Screen

The HOME screen is the default display and represents the *Analysis Mode* of the instrument. It is a set of two screens that present information regarding the current measurement state. The HOME screen is where the maximum information about the instrument is displayed.

The Group name/tag is listed on the left most column and the concentration for groups are displayed in PPB, PPM or % depending on the range and value. The Enabled group is represented by the glowing LED. Each group has three user settable ranges R1, R2, and R3 and the current range index is displayed in the Group row. It is possible to view the VS (Volt-second) count by touching the “Vs Count” button.

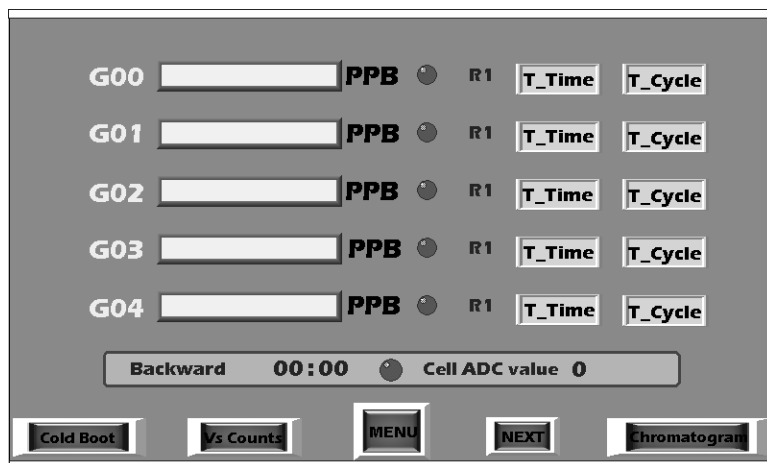

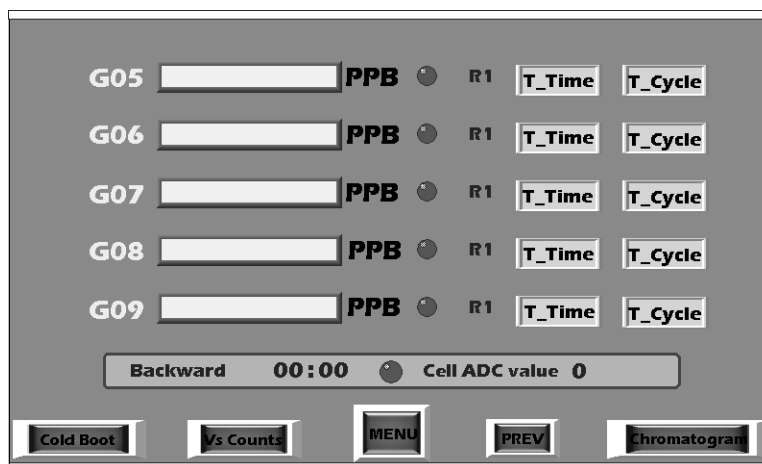

The phase cycle (forward or reverse) and corresponding phase timer along with the cell ADC value are displayed in the lower box. The green LED within the rectangle starts blinking whenever a peak is detected for active time frames (groups) running in the respective cycle.

The ten groups are split into two screens showing five on each screen. Either screen can be displayed by selecting “NEXT” and “PREV” on the HOME screen.

A “Cold Boot” button is located on the bottom left corner of the HOME screen that when pressed will allow the user to revert back to factory settings or retain the current instrument settings. See Section 4.5.13.5 for additional details regarding a cold boot.

Each group has buttons associated with it (T_Time and T-Cycle) that will bring up a graph displaying the analysis trend in the group with respect to time or cycle. With these buttons, the user can evaluate the instantaneous analysis as opposed to waiting for a complete cycle to terminate. See Section 4.5.13 for more details.

4.5.3 The MENU Screen

Instrument parameters can be accessed and set by pressing the “MENU” button on the HOME screen. This brings up the following MENU screen:

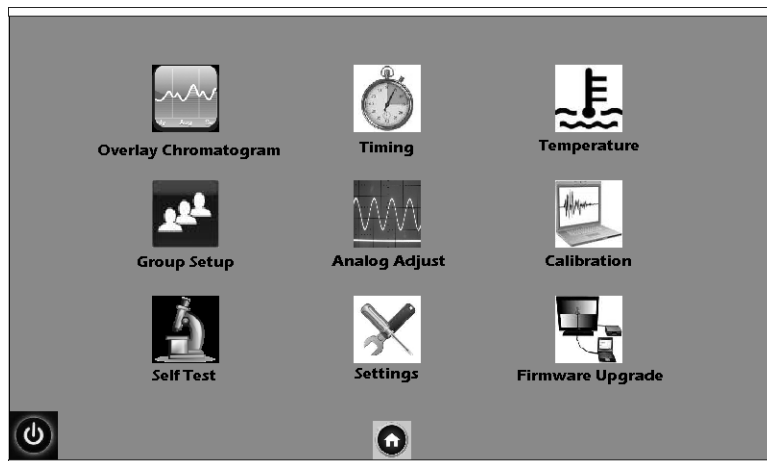

Any function can be entered by touching the respective icon. The functions are:

- Standby (lower left corner on display)
- Home (home icon at bottom center)
- Overlay Chromatogram
- Timing
- Temperature
- Group Setup
- Analog Adjust
- Calibration
- Self Test
- Settings
- Firmware Upgrade

These functions are described in the sections that follow.

4.5.4 Standby

This function allows you to place the instrument in STANDBY mode.

CAUTION: STANDBY SHUTS DOWN POWER TO THE DISPLAYS ONLY. INTERNAL CIRCUITS ARE STILL ENERGIZED AND ELECTRICAL SHOCK HAZARD STILL EXISTS.



To place the instrument in STANDBY status press the “Standby” button at the lower left corner of the display. The following Confirmation screen will pop up.



Selecting ‘OK’ puts the system goes into a sleep mode and following window will be displayed on the screen.

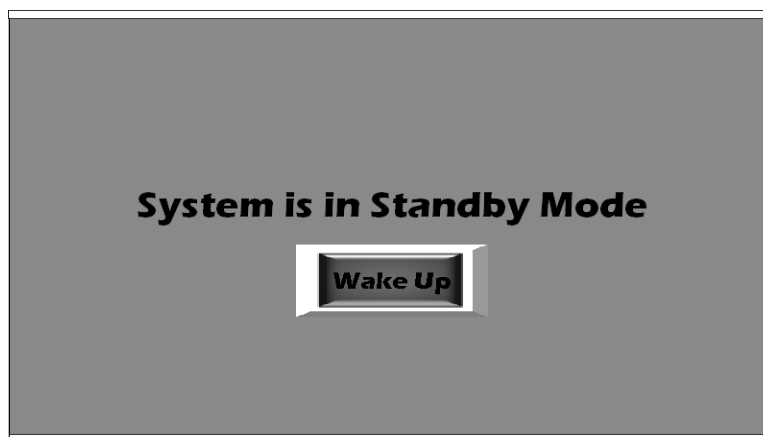

To come out of standby mode, touch the “WAKE UP” button. An informational pop up screen will appear for approximately one minute displaying a message “Please wait.....”.

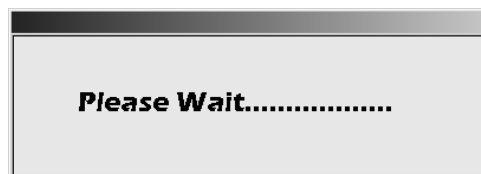

4.5.5 Overlay Chromatogram

Selecting “Overlay Chromatogram” brings up the following screen:



The above screen displays the overlay chromatogram with the ADC values on y axis plotted against the sample number on the x axis. To display the graph onscreen, touch the “PLOT” button. To clear the screen touch “REFRESH”.

Use the “Scale” button to change the X axis or Y axis scaling.

Note: The chromatogram will be displayed for a maximum of 1020 samples. The chromatogram will not display if the total sum of the forward phase duration & backward phase duration is more than 1020 seconds.

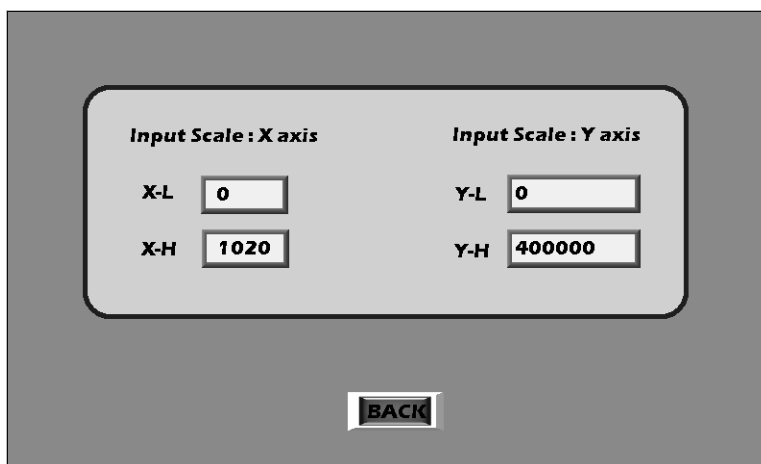

In this screen, low and high limits on the X and Y axes can be input. The maximum limit for X-High is 1020 i.e., 1020 seconds. So the maximum cycle time (forward + backward) time should not exceed 1020 seconds (17 min) for the overlay chromatogram.

The user can also select the number of channels to be plotted on the overlay chromatogram screen by selecting the "Setting" icon from the MAIN menu. Doing so will display the Setting submenu screen as shown below.

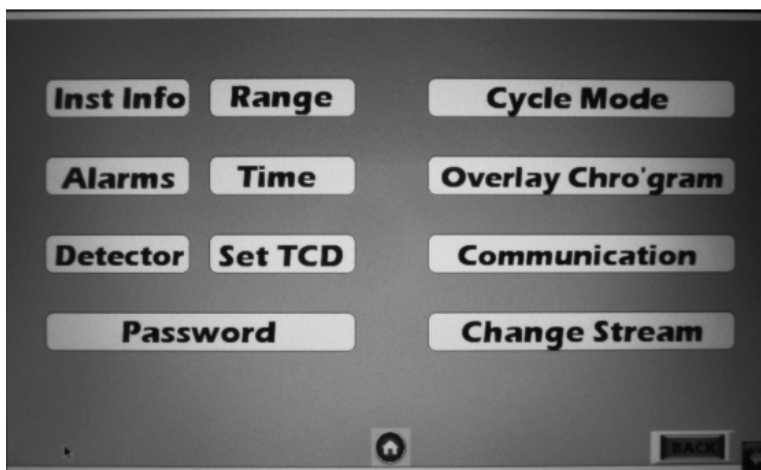

From this menu, touch the "Overlay Chro'gram" button. This will bring up the CHANNEL SELECTION window as shown below.

Use the UP ARROW to select the number of channels then touch ENTER to confirm the selection or CANCEL to abort the selection and

return the previous selection. This screen also provides the color indicators for the plot on the various channels. These colors are fixed and cannot be changed.

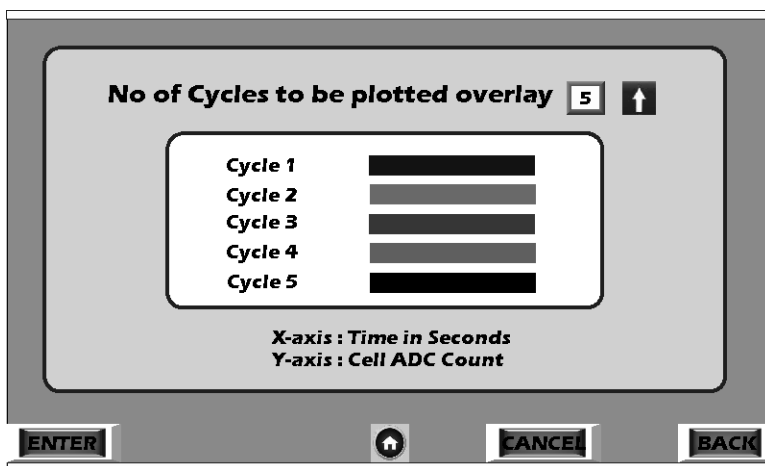

4.5.6 Timing

Timing controls the parameters of the valve and data acquisition. It is specific to the setup of the instrument and must be determined at the factory or TAI trained personnel. Refer to the *Addendum and Testing Results* section of Appendix C for the specific timing settings used for your system and application. Do not change these values unless directed by Customer Service at TAI. For further information please contact TAI Customer Service.

In the event the timing must be changed or viewed, touch the “Timing” icon on the MENU screen. The following screen is displayed.

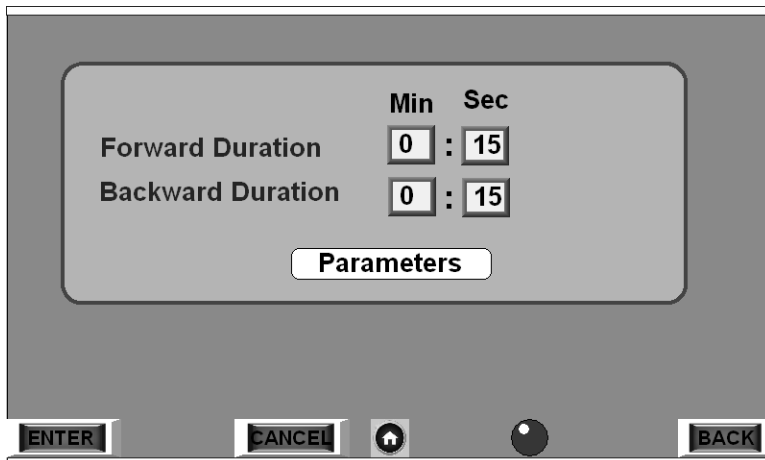

The window screen is used to set the forward and backward duration in MM:SS format. After setting the required duration, select the ENTER button to save the values.

If the onscreen LED is red, all available buttons will be disabled and timing cannot be adjusted. Wait until the LED turns green again before resuming any button presses.

Note: The chromatogram will be displayed up to a maximum of 1320 samples i.e. if the sum of the forward plus backward phase duration is more than 1320 seconds. Beyond that value, that the chromatogram will not be displayed.

With the LED green, the “Parameters” icon can be selected to view and edit several parameters for each time frame, as shown in the screen below.

Sum	Active	Phase	Begin Time	End Time	Edit
S00	<input type="radio"/>	Backward	0 : 3	0 : 10	Edit
S01	<input checked="" type="radio"/>	Backward	0 : 0	0 : 0	Edit
S02	<input checked="" type="radio"/>	Backward	0 : 0	0 : 0	Edit
S03	<input type="radio"/>	Forward	0 : 4	0 : 14	Edit
S04	<input checked="" type="radio"/>	Backward	0 : 0	0 : 0	Edit
S05	<input checked="" type="radio"/>	Backward	0 : 0	0 : 0	Edit
S06	<input type="radio"/>	Forward	0 : 5	0 : 10	Edit
S07	<input checked="" type="radio"/>	Backward	0 : 0	0 : 0	Edit
S08	<input checked="" type="radio"/>	Backward	0 : 0	0 : 0	Edit
S09	<input type="radio"/>	Backward	0 : 6	0 : 8	Edit

The above screen displays the Phase, Begin Time and End Time along with the active ON/OFF field. The screen also contains an EDIT button that can be used to view or modify all the parameters for the selected timeframe, as shown below.



The parameters can be modified by either touching the UP arrows or by entering the values in input fields.

In order to input the Begin/End Time, touch on the Green “EDIT TIME” button. This causes an input window to appear as shown below.



In this screen, the Begin/End Time can be changed (minutes and seconds) by touching the requisite box. A pop up numerical keypad appears onscreen that allows the direct input of numerical values.

If an inappropriate value is input, for example a Begin time greater than the End time or an End time which exceeds the selected (FWD+BCK) phase duration, an onscreen warning will appear as shown below.

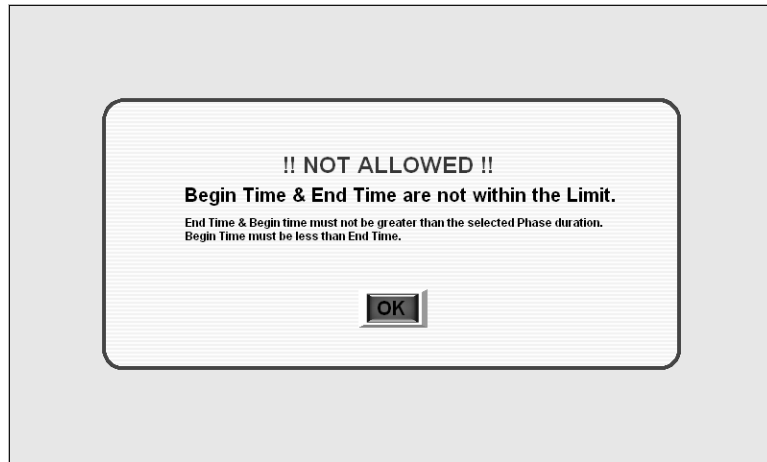

Once a valid input has been entered as shown in the example screen above, the display will return to the Parameter window, which will now reflect the modified values.



After modifying the above parameters touch the ENTER button to save the new inputs. A confirmation window will pop up before actually saving the inputs. Select OK to save, otherwise touch CANCEL to reject the new inputs.

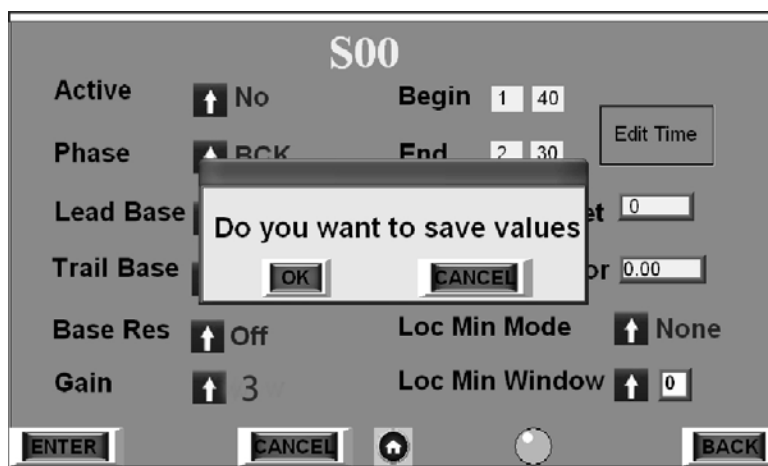

4.5.6.1 TCD AMPLIFIER GAIN

The GC-Pro TCD allows separate gain adjustments on the TCD amplifier. This affects the detector sensitivity and is most noticeable when zeroing or making fine adjustments to the TCD detector as described in Section 4.5.12.8. The amplifier gain can be set in the GAIN field using a valve from 0-9 with 0 representing no gain and 9 the maximum gain. Each component can have its own gain setting.

To set the gain, press the TIMING icon from the MAIN screen and then press PARAMETERS. Select the component desired and then EDIT. Enter a value from 0 to 9 in the GAIN field to set the desired gain setting. Press ENTER and the save requester will appear which will allow the gain setting to be changed (ENTER) or cancelled (CANCEL) making no changes and returning the previous gain setting.

4.5.7 Temperature

Temperature control is a critical factor in GC analysis. The GC-Pro TCD Analyzer incorporates three dedicated heaters with temperature control PCBs.

- Sensor
- GC Column
- Sample Chamber

Refer to the *Addendum and Testing Results* section of Appendix C for the specific temperature setpoints used for your system and application. Do not change these values unless directed by Customer Service at TAI. For further information please contact TAI Customer Service.

Caution: *The temperature settings have been carefully determined and set at the factory for your application. Temperature is a key factor in determining the accuracy of the resultant analysis. It is recommended that the user consult TAI before making any changes to the temperature setpoints as listed in Appendix C of this manual.*



To monitor the temperatures, check the status of a thermocouple or change a temperature controller setpoint select “Temperature” from the MAIN screen. The following screen will display.

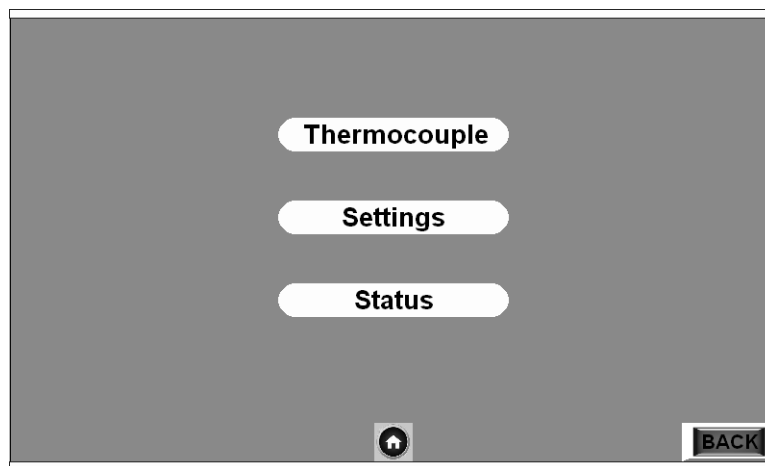

4.5.7.1 THERMOCOUPLE

Selecting “Thermocouple” from the Temperature menu shows the actual temperature reading (°C) of the three sections: Sample, Sensor, and Column.

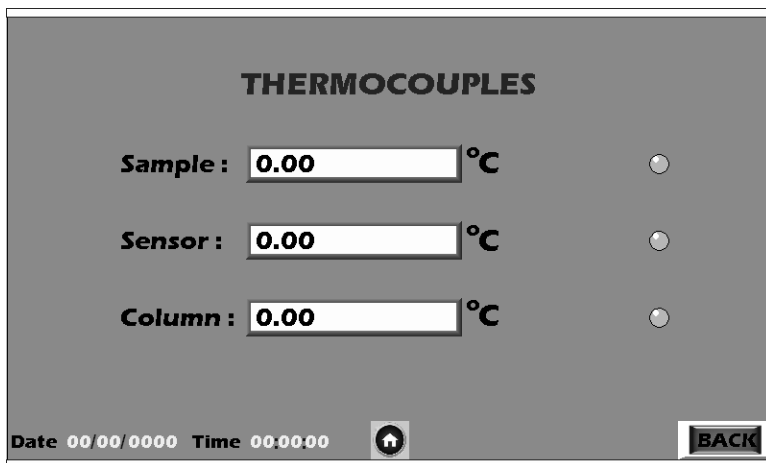

The temperature sensor value will be displayed in degrees Centigrade. If the values are within the limits the green LED will be illuminated. The LED will be red if the values are above or below the setpoint limits. The screen also displays the date and time of the thermocouple data acquisition. The values are updated every five seconds.

4.5.7.2 SETTINGS

To redefine the limits and offset for the thermocouple values, press “Settings” from the Temperature screen. The following screen will appear.

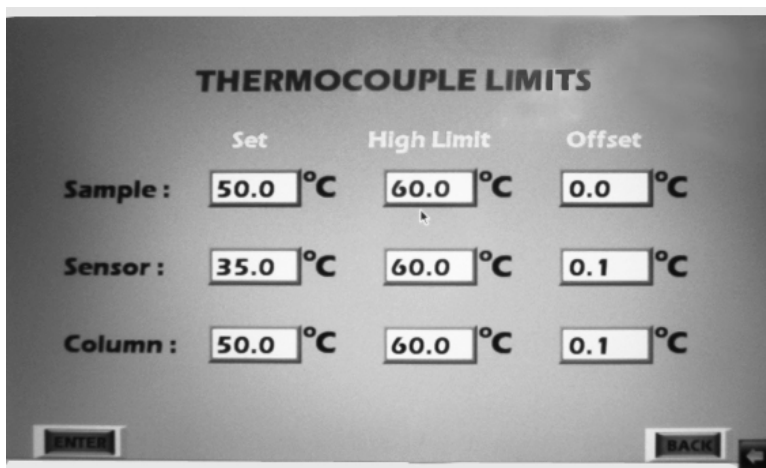

Pressing any data box will bring up an onscreen numerical keyboard that allows data input. When finished making setpoint, limit and offset changes, press ENTER to return to the Temperature screen.

4.5.7.3 PID SETTINGS

The temperature controllers used in the GC-Pro TCD are three-term controllers with proportional (Kp), Integral (KI), and derivative (Kd) settings. Together, these parameters determine the overall control and response of the instrument.

Optimum values for Kp, KI, and Kd have been determined at the factory and set for your instrument. The PID Settings menu from the Temperature main menu will display the current values for each of the three heaters and allow the user to modify the setting.

To access the parameters, press PID Settings from the Temperature screen.

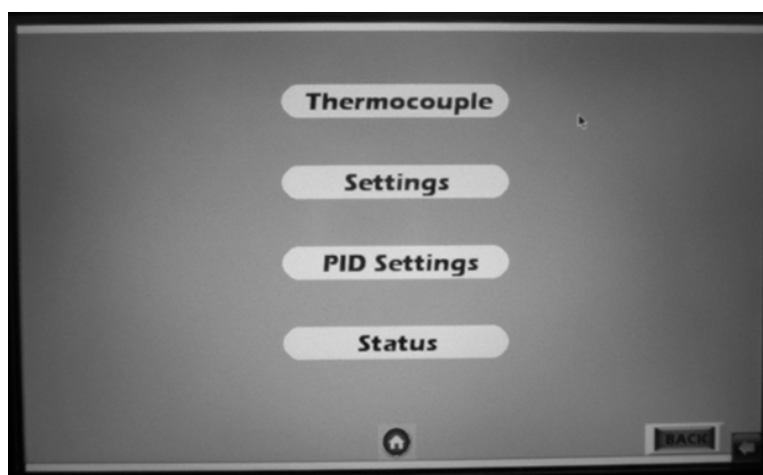

Pressing PID Settings will bring up the following screen that displays the current settings for each of the three temperature controllers.

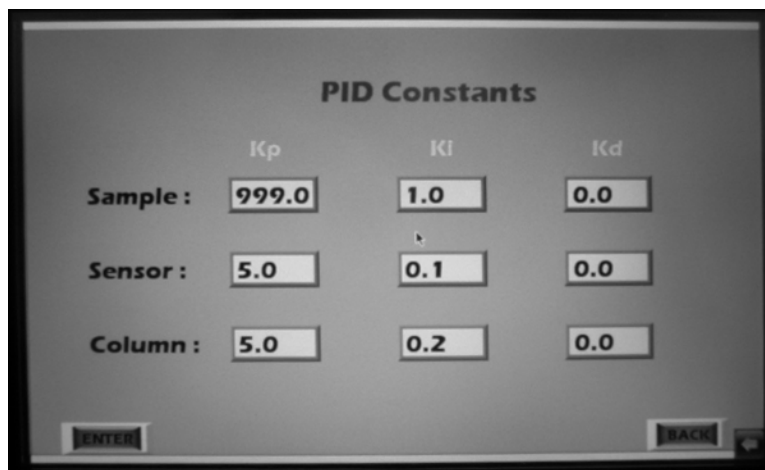

You can adjust any of the three PID constants by touching the data box and entering a new value into the numerical entry box that pops up. Once the value has been entered, press ENTER on the entry box to accept the value and dismiss the numerical entry box. After all parameters have been set, save the values by pressing ENTER on the lower left corner of the screen. This will return you to the Temperature main screen.

4.5.7.4 STATUS

The STATUS screen displays the status for the three thermocouple sensors. If a thermocouple is open or damaged, this condition will be indicated by the message "Broken" in the corresponding sensor column. Otherwise, if a thermocouple is operating properly "Normal" will be displayed in the sensor column.

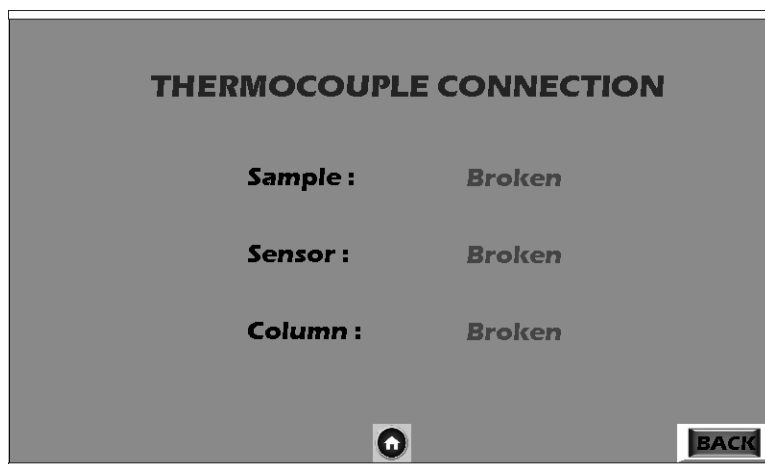

4.5.8 Group Setup

Group Setup assigns to each compound a name, a range given in Range settings and an associated peak window that is determined in Timing settings. These values should not be modified unless directed by TAI customer Service.

When the Group Setup icon on Main Menu is selected, the following screen is displayed.

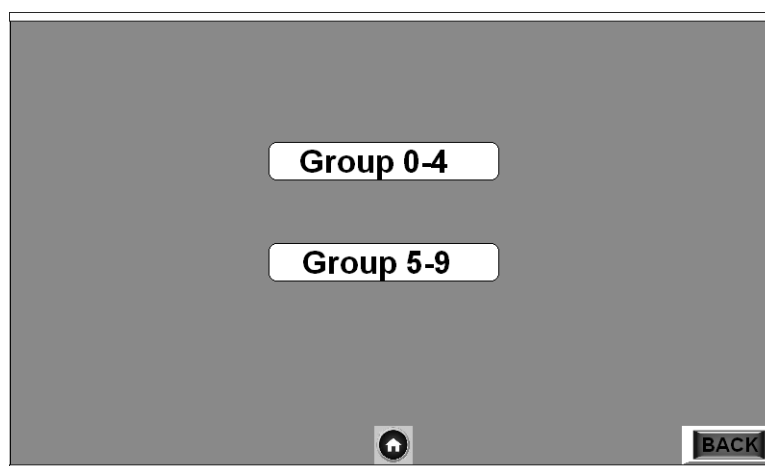

The Group Setup is function split into two screens covering Groups 0-4 and 5-9 on individual setup screens. The Group Setup screen gives the option to display either half of the Groups by touching the relevant icon. When user touches the “Group 0-4” icon, a new window appears as shown below.

Group	Y/N	Tag	Range	T-Frame	En-Sxx
G00	<input type="radio"/>	BNZ	R1 ↑	SUM	S00
G01	<input type="radio"/>	CH4	R1 ↑	SUM	S00
G02	<input type="radio"/>		R2 ↑	SUM	S00
G03	<input type="radio"/>		R3 ↑	SUM	S00
G04	<input type="radio"/>		R3 ↑	SUM	S00

A	B	C	D	E	F	G	H	I	J	K	L	M	1	2	3	4	5	6	7	8	9	0
N	O	P	Q	R	S	T	U	V	W	X	Y	Z	BS	Clear	Enter							

ENTER	CANCEL	Home	Power	BACK
-------	--------	------	-------	------

From these screens (0-4 and 5-9) a specific group or groups can be selected, names (tag) assigned, a range assigned as well as concentration peaks (Sxx) added or subtracted.

A group is selected by touching the adjacent LED. When selected it the LED icon should turn green.

A tag is limited to three characters (letters or numbers 0-9). A tag can be assigned by touching any three keys provided in the on-screen keypad after selecting the tag field for the relevant group. You must press ENTER on the **keypad** to assign the tag before moving to another setting or group, otherwise the tag will NOT be assigned.

To assign a range, touch the UP arrow button adjacent to the range of the selected group.

Once all the required inputs have been made, select ENTER to save. A confirmation window pops up to confirm the inputs or cancel.



*Note: You can view the first of the Enabled Sxx on the Group Setup screen for the respective Groups. If none of the Sxx are enabled S** will be displayed. Details for enabling the Sxx are given below.*

It is possible to add or subtract concentration peaks to groups using the SUM function available from the Group Select screen.

Selecting SUM from a selected group brings up an additional screen.

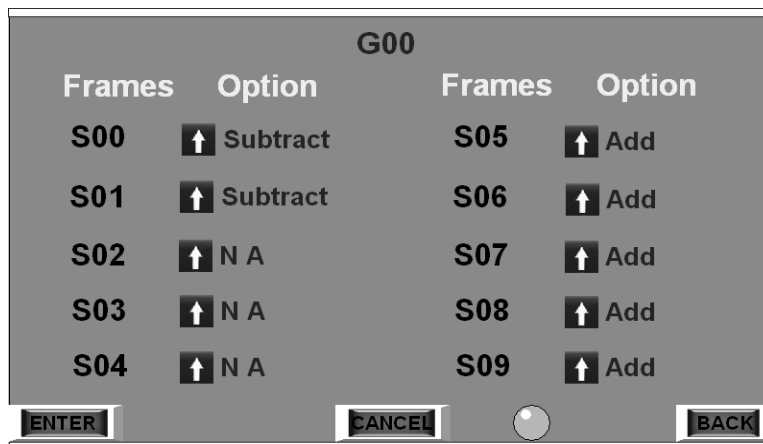

This screen has three inputs for ten peaks S00 through S09. The possible inputs are Subtract, Add, and NA (Not Applicable). The user can assign these inputs by touching the UP arrow button available. After touching the ENTER button to save the inputs, a confirmation window pops up.

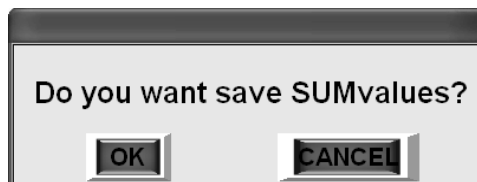

Note: After selecting the ENTER button there will be a delay of few seconds to update the inputs. All other buttons (i.e. home, cancel, back etc) available on the screen will be disabled during the delay period.

As an example, assume Groups G00 and G01 have been setup to monitor two different hydrocarbons with peaks associated as follows:

Group	Assigned Peak
G00	S00
G01	S01

Then, it is possible to setup a group to monitor total hydrocarbon as G03 which would have both hydrocarbon peaks assigned to it by using the SUM function:

Group	Assigned Peak
G00	S00
G01	S01
G02	S01 + S02

Similarly, group setup inputs can be provided for the other five groups by selecting Group 5-9 icon on the first Group Setup screen.

4.5.9 Analog Adjust

The GC-Pro TCD Analyzer has ten 4-20 mA DC output channels that can be assigned to the various groups. Any group can be assigned to any output channel and it is also possible to assign groups to multiple channels.

Channel 0 and channel 2 are unique channels. For these channels the user can assign gain and offset values to the output. Channel 0 has an additional feature called “WAVE” which when selected will assign the ADC counts to the 4-20 mA output for the group assigned to channel 0.

Note: The WAVE function will not be accessible until a group has been assigned to channel 0.

Selecting Analog Adjust from the MAIN screen brings up the following screen.

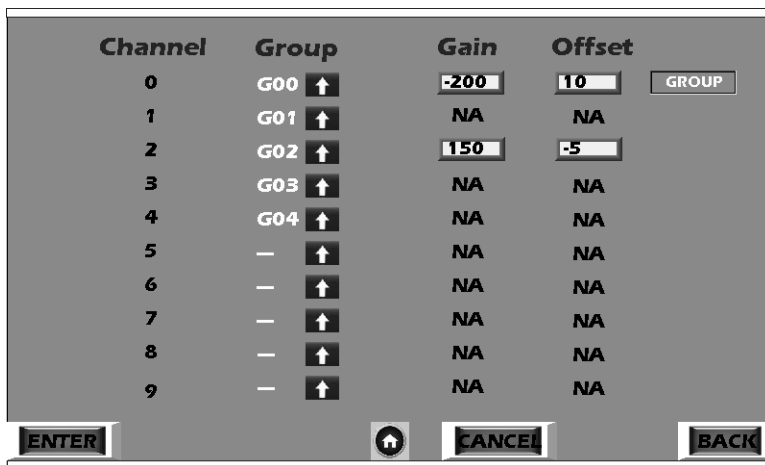

Pressing GROUP and assigning a specific group to Channel 0, the screen changes to:

Channel	Group	Gain	Offset	
0	— ↑	-200	10	WAVE
1	G01 ↑	NA	NA	
2	G02 ↑	150	-5	
3	G03 ↑	NA	NA	
4	G04 ↑	NA	NA	
5	— ↑	NA	NA	
6	— ↑	NA	NA	
7	— ↑	NA	NA	
8	— ↑	NA	NA	
9	— ↑	NA	NA	

ENTER HOME CANCEL BACK

where WAVE function is now available.

Any group that is available (see Section 4.5.8 *Group Setup*) can be assigned to any output channel.

To assign a group to a channel: (INFORMATION REQUIRED ON HOW TO DO THIS)

4.5.10 Calibration

The SPAN function is used to calibrate the analyzer. Span can be performed either manually or automatically with the auto calibration function if equipped. Typically, each group will require a separate calibration.

The analyzer is calibrated using span gas as described in Section 4.4.2. See also Appendix C *Addendum and Testing Results* for any specific requirements regarding span gas for your application. This section assumes that this gas has been properly connected and the line checked for leaks.

To initiate a span calibration, touch the Calibration icon on the MAIN screen. The following screen is displayed.

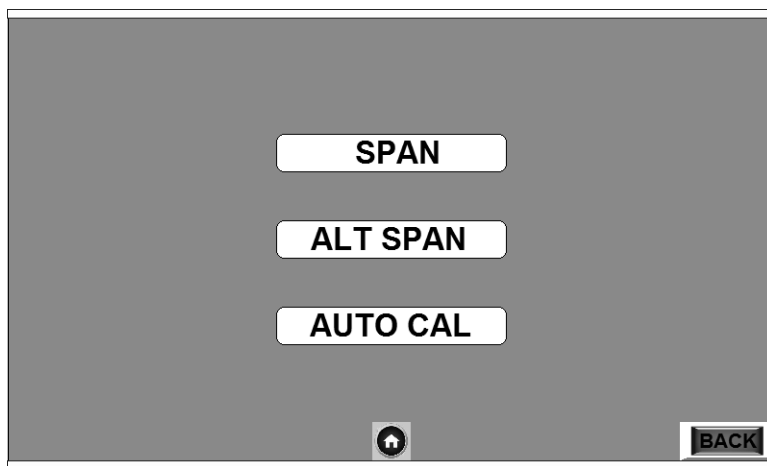

4.5.10.1 SPAN

When user touches SPAN the following screen is displayed.



This screen allows the user to select which group or groups to calibrate. There are two separate screens, one for groups 0 through 4 and another for groups 5 through 10. Both screens function identically and allow the user to input the concentration of the known span gas for each group, set the concentration unit as parts per billion (ppb), parts per million (ppm) or percent (%) and span calibrate the group or groups.

Selecting "GROUP 0-4" brings up the following screen:

Group	Y/N	PPB	PPM	%
	<input checked="" type="radio"/>	<input type="text" value="0"/>	<input type="text" value="0.00"/>	<input type="text" value="78.14"/>
	<input type="radio"/>	<input type="text" value="0"/>	<input type="text" value="0.00"/>	<input type="text" value="55.66"/>
	<input type="radio"/>	<input type="text" value="0"/>	<input type="text" value="0.00"/>	<input type="text" value="60.78"/>
	<input type="radio"/>	<input type="text" value="0"/>	<input type="text" value="0.00"/>	<input type="text" value="88.55"/>
	<input checked="" type="radio"/>	<input type="text" value="0"/>	<input type="text" value="0.00"/>	<input type="text" value="90.23"/>

ENTER SPAN BEGIN  CANCEL BACK

A similar screen displays if Group 5-9 is selected.

Group	Y/N	PPB	PPM	%
	<input type="radio"/>	<input type="text" value="781400000"/>	<input type="text" value="781400.00"/>	<input type="text" value="78.14"/>
	<input type="radio"/>	<input type="text" value="556600000"/>	<input type="text" value="556600.00"/>	<input type="text" value="55.66"/>
	<input type="radio"/>	<input type="text" value="607800000"/>	<input type="text" value="607800.00"/>	<input type="text" value="60.78"/>
	<input type="radio"/>	<input type="text" value="885500032"/>	<input type="text" value="885500.00"/>	<input type="text" value="88.55"/>
	<input checked="" type="radio"/>	<input type="text" value="902300032"/>	<input type="text" value="902300.06"/>	<input type="text" value="90.23"/>

ENTER SPAN BEGIN  CANCEL BACK

A lit green LED next to a group indicates the group is enabled (selected) for calibration. An unlit green LED means the group has not been selected and will not be calibrated. Touching on the group's LED will toggle the LED between lit (enabled) and unlit (deselected).

The SPAN value inputs for each selected group in any of the three units PPB, PPM or Percent can be entered by touching the respective yellow LED next to the correct unit input box. A numerical keyboard will pop up allowing the user to input the known composition of the

span gas. After inputting the value, press ENTER on the pop up keyboard to input the value into the box.

Only inputs with the glowing yellow LED will be affected. When user touches the ENTER button the inputs with the glowing yellow LED will be saved following confirmation on the pop up screen.

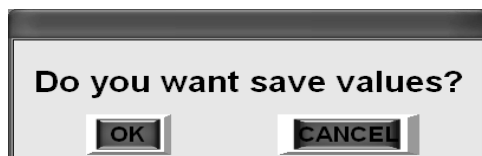

To initiate the calibration, touch the "SPAN BEGIN" button and then "OK" on the next pop up screen to calibrate the analyzer for the selected groups.



Once calibration is complete, the display will revert to the HOME screen. The same procedure can be followed for calibrating groups 5-9.

4.5.10.2 ALT SPAN

If a particular compound of interest is not available or not contained in the span gas, another compound existing in the span gas can be used for the alternate calibration. This requires assigning a factor that results in a best fit approximation to the calibration standard normally required for that group. These factors must be determined by the factory since entering an incorrect value will seriously affect the measurement capability of the instrument for that group. For this reason, TAI recommends contacting customer service before using the Alt Span function.

Touch the ALT SPAN listing on the Calibration screen to enter the Alt Span function. The following screen is displayed:

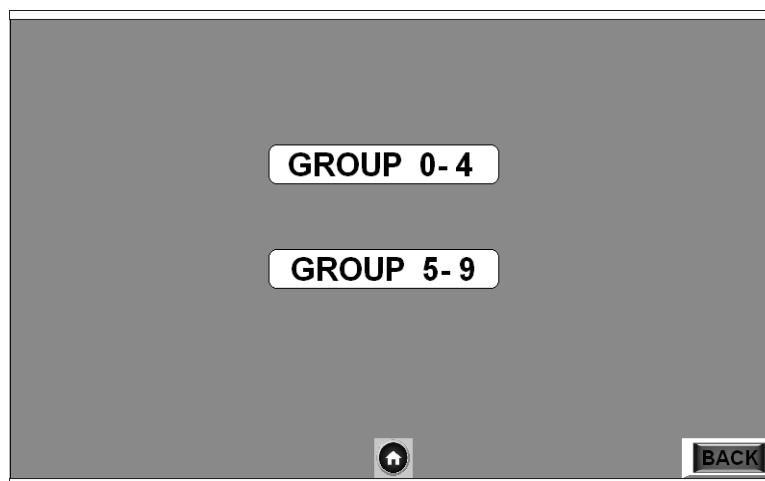

The function is split into two screens addressing to Groups 0-4 and 5-9. The screen below shows the display addressing Groups 0-4 (Group 5-9 screen is similar).

Group	Include	Factor
G00	<input type="radio"/>	↑04.2↑
G01	<input type="radio"/>	↑07.1↑
G02	<input type="radio"/>	↑04.3↑
G03	<input type="radio"/>	↑05.6↑
G05	<input type="radio"/>	↑10.0↑

At the bottom of the screen are buttons: ENTER, Perform AltSpan, a home button, CANCEL, and BACK.

In this screen a dark green color on the LED in the “Include” column adjacent to a group indicates that Alt Span is currently disabled for that group. A bright green LED indicates that Alt Span is enabled for the corresponding group. The Alt Factor value can be entered into the box in two phases i.e., an integer part using the UP arrow on the left and a fractional part using the UP arrow on the right.

Once the appropriate values have been entered select ENTER to save the factor. A confirmation screen will arise asking the user to confirm the changes before saving.

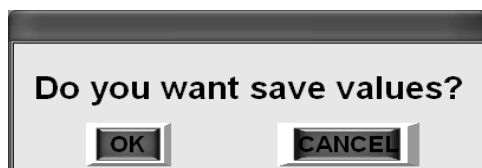

After confirmation, a display screen will appear where the user can be the currently saved factor. If you "Cancelled" the entry on the last screen, the previous Alt Span factor will be used.

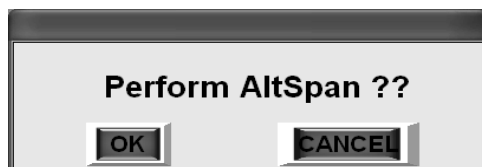

To initiate an Alt Span calibration, touch "OK" to bring up the next screen to select which group to span on or "CANCEL" to exit the Alt Span function.

After pressing "OK" the next screen appears.



Use the "UP/DOWN" arrows to enter the group to span on and then press "ENTER" to begin the calibration or "CANCEL" to exit the function.

Once the calibration has completed the HOME screen will appear on the display.

Use the same procedure for performing an Alt Span on any member or members in Groups 5-9.

4.5.10.3 AUTO CAL

The GC-Pro TCD Analyzer can be fitted with an external auto calibration module as an option. This feature provides automatic switching of sample and calibration gases and allows the operator to program calibration events to occur automatically

Note: If your instrument is not fitted with an auto calibration module, the auto calibration screens will still appear on the display but will be non-functional.

Note: Before setting up an AUTO CALIBRATION, be sure you understand the Span function as described in Section 4.5.10.1 and follow the procedures given there for inputting the calibration gas compositions for each group etc. Auto Span performs a span calibration using the target span value set that has been set in the Span feature menu.

To setup an auto calibration cycle for a span events to occur in a certain number of days/hours select the “Auto Cal” button from the Calibration screen. The Auto Cal screen is displayed.

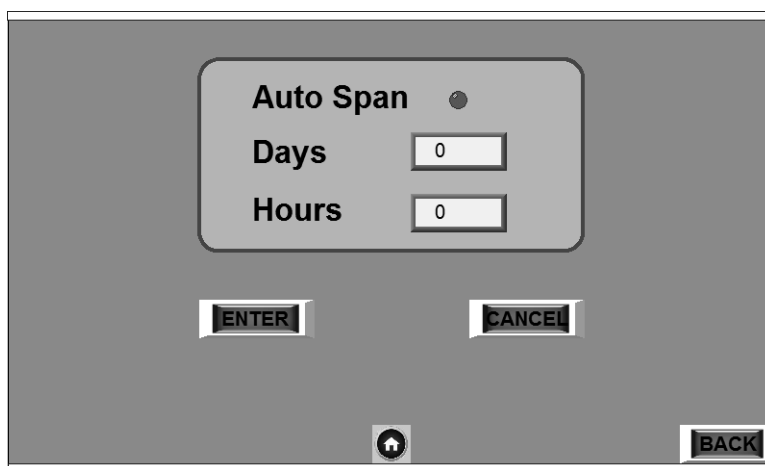

A dark green color of the LED button adjacent to the Auto Span indicates that Auto Span is disabled while a bright green color means that the Auto Cal feature is enabled.

Touching the text box adjacent to either Days or Hours brings up a numeric keypad for entering the time between calibration events (up to 255 day and/ or 24 hours). On numeric display user can see max and min numeric value he can enter. After entering the value, press ENTER to place the value into the onscreen box (days or hours). When the correct values have been loaded into the Days and the Hours boxes, touch the Green LED adjacent to Auto Cal to toggle it to the lit (bright green) state. This enables the Auto Span feature. Or toggle it to the unlit (dark green) state to disable auto calibration.

After pressing ENTER, a confirmation window pops up. Selecting “OK” all inputs will be registered and the auto cal status as determined by the state of the green LED will become active.

Touching the CANCEL button will abort the present inputs and revert back to the last saved values and state.

Auto Cal countdown (if enabled) will begin as soon as the display returns to the HOME screen by pressing the HOME icon.

4.5.11 Self Test

The GC-Pro TCD has a built-in self-diagnostic testing routine which automatically runs whenever the instrument is powered up. The self-testing routine can also be run by the operator at any time by pressing the Self-Test icon on the MAIN screen.

In the self-test routine, preprogrammed signals are sent through the power supply, output board, preamp board and sensor circuit. The return signal is analyzed, and at the end of the test the status of each function is displayed on the screen as either “GOOD” or “BAD”. If any of the functions fail, the System Alarm is tripped.

Note: The self diagnostics will interrupt analysis temporarily.

To initiate a self-test from the MAIN screen press the Self Test icon and then select either “Main Board” or “9261 Board”

Selecting “Main Board” displays the following screen:

RUNNING DIAGNOSTICS	
TESTS	RESULTS
5V Test	
15V Test	
DAC A Test	
DAC B Test	

After about one minute the results of the self test is displayed as “GOOD” or “BAD” for the various tests. Once the diagnostic test has begun, it cannot be stopped. After performing the self test the display will revert back to the Self Test screen where you can continue the diagnostics by selecting “9261 Board”.

RUNNING DIAGNOSTICS	
TESTS	RESULTS
5V Test	
15V Test	
DAC A Test	
DAC B Test	
T1 Test	
T2 Test	
T3 Test	
T4 Test	

After about one minute the results of the self tests are displayed as “GOOD” or “BAD”. The T1 to T4 tests analyze the 4 thermocouples for continuity. Once the user enters into this screen there is no option for stopping the self test in the middle. After performing the self test the screen automatically reverts back to the self test screen.

4.5.12 Settings

Touching the Settings icon brings up a screen with ten functions that are used to customize the analyzer to your specific needs plus one information only screen. The functions available are:

- **INSTRUMENT INFORMATION:** An information only screen which displays Manufacturer, Model, and Software version of the instrument.
- **RANGE:** Used to set up three analysis ranges that can be switched manually.
- **ALARMS:** Used to set the alarm setpoints and determine whether each alarm will be active or defeated, HI or LO acting, and failsafe or not.
- **TIME:** Used to set the current date and time on the instrument.
- **DETECTOR:** Selects the detector used in the instrument.
- **SET TCD:** Allows for coarse and fine adjustments on the TCD detector.
- **PASSWORD:** Used to establish password protection or change the existing password.
- **CYCLE MODE:** Toggles measurement mode between continuous measurement and single shot (measure once) measurement and adjusts the fill time used by the sample valve.
- **OVERLAY CHROMATOGRAM:** Brings up the chromatogram display.
- **COMMUNICATION:** Selects between four different RS232 protocols.
- **CHANGE STREAM:** Used to manually switch between sample and calibration gas.



Pressing the “Settings” icon displays the following screen:



4.5.12.1 ALARMS

The GC-Pro TCD provides two concentration alarms with relays. When an alarm condition exists, the relay or relays will change state. The relays are available from the 50-pin Equipment Connector as described in Section 3.3.2.5 and 3.3.2.9. The alarms screens are used to configure how the concentration alarms operate.

There are two identical screens within the ALARMS function, one for setting the parameters on ALARM 1 and the other for ALARM 2.

Pressing the ALARMS button brings up a screen where you can change or view the alarm parameters for either Alarm 1 or Alarm 2.

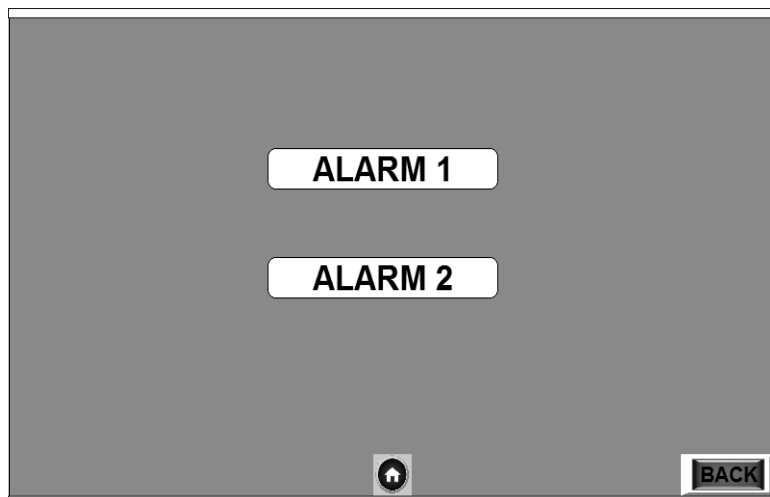

Selecting ALARM 1 displays the following screen:



From this screen you can make Alarm 1 active or defeated, configure it as a high or low alarm, failsafe or non-failsafe and whether the alarm will be latching or non-latching by touching the respective LED's.

The user can enter the trigger value (alarm setpoint) by touching in the Trigger Value box. This causes a numeric keypad to display for entering the value. Hit ENTER to close down the keypad and enter the value into the Trigger Value box.

The user can also select the group to which the Alarm will be associated by using the UP/DOWN arrows adjacent to the Source box.

The configurable items are as follows:

DEFEATED: If an alarm is defeated, its relay is de-energized, regardless of failsafe condition. A defeated alarm does not react to a transition over its trip point in either direction.

HIGH: If an alarm is set as HIGH, it will not create a new alarm condition (see latching) if the analysis concentration is below the trip point, if the analysis concentration is above the trip point, then an alarm condition will be created or maintained.

FAILSAFE: A non-defeated alarm that is in FAILSAFE mode *energizes* an alarm relay in a non-alarm condition and *de-energizes* an alarm relay in an alarm condition.

Note: Failsafe condition of an alarm is a software property. This is not related to relays that have both normally-open and normally-closed terminals.

LATCHING: The latching property configures the alarm such that the user must manually relieve the alarm condition even though the concentration no longer violates the trip point of the alarm. So, if an alarm is NON-LATCHING, and the analysis concentration temporarily drifts above the trip point of a HIGH alarm, the alarm condition occurs only during the time the concentration is above the trip point. If that alarm were LATCHING, the alarm condition would persist (even though the concentration is no longer above the trip point), until the user released it.

RELEASING A LATCHED ALARM: When alarm conditions are present, the relay associated with that alarm changes state. To reset from an alarm condition, enter the Alarm 1 or Alarm 2 screen and disable the alarm. Then re-enable the alarm. If the alarm condition still exists, the alarm will again trigger.

TRIGGER POINT: This is the threshold at which an active alarm can enter into alarm condition. If an alarm is HIGH, ACTIVE, and set at 20.00 ppb, then when the analysis concentration is at or above 20.00 ppb an alarm condition is initiated or maintained.

CAUTION:  **IT IS NOT GOOD PRACTICE TO SILENCE AN EXISTING ALARM BY SETTING THE ALARM ATTRIBUTE TO 'DEFEAT'. THE ALARM WILL NOT AUTOMATICALLY RETURN TO "ACTIVE" STATUS. IT MUST BE RESET BY THE OPERATOR. IF IT IS NOT RESET, YOUR PROCESS WILL BE RUNNING WITHOUT THE SAFEGUARDS THIS INSTRUMENT IS DESIGNED TO PROVIDE.**

When finished configuring the alarms, touch the ENTER button at the bottom right corner of the screen. A confirmation window will pop up and by selecting "OK" the new alarm configuration will be the active settings. Then, by touching the HOME icon, all alarm 1 inputs will be saved permanently. Touching the CANCEL button will abort the inputs and return the previously saved values.

The ALARM 2 screen is an identical screen for configuring ALARM 2.

Note: An alarm in 'alarm condition' is signaling that action must be taken such as correcting the alarm or the analysis concentration. If an active (not defeated) alarm has been set to HIGH at 20.0 ppb, and the analysis concentration is above that level, then the 'alarm condition' is occurring.

4.5.12.2 RANGE

There are three settable analysis ranges on the GC-Pro TCD Analyzer. Both upper and lower bounds may be set. The value of each limit on the currently selected range affects the corresponding upper and lower value of the voltage and current of the analog outputs of the analyzer as well as contact closures (if present) indicating which range is current. The analog outputs from the 50-pin Equipment connector (see Section 3.3.2.3 and Table 3-1) represent the proportion of the analysis concentration to the currently selected range limit.

RANGE LIMITS: Ranges may be set for ppb, ppm, or percent analysis however, range 3 can only be set at a value greater than range 2 and range 2 can only be set at a value greater than range 1. In addition, the lower bound on each range must always be less than the upper bound.

To set the ranges select “Range” from the SETTINGS screen. The following screen will appear:

Range		PPB	PPM	%
Range 3	HIGH	100000000	1000000.00	100.00
	LOW	950000000	950000.00	95.00
Range 2	HIGH	100	0.10	0.00
	LOW	0	0.00	0.00
Range 1	HIGH	10	0.01	0.00
	LOW	0	0.00	0.00

ENTER HOME CANCEL BACK

Once the input range has been decided, press the corresponding LED icon to turn it on. Touch the input box and a numerical keypad will display from which you can enter the upper range limit (the lower limit on each range is always zero). Once the value is entered, press ENTER to dismiss the keypad and enter the value into the range box selected.

When finished, touch the ENTER button and the inputs with the glowing yellow LED will be converted in other available units and a confirmation pop up window will appear. Press “OK” button to proceed further.



Repeat the procedure for the other two ranges.

If the range values entered by the user does not follow the order R3>R2>R1 then a warning will display.



Touching the “OK” button allows the user to input the values again. If the input values follow the order R3>R2>R1; a final confirmation window pops up on the screen. Select OK to save or CANCEL ignore the entered inputs.



4.5.12.3 CHANGE STREAM

The Change Stream function is used to manually select between sample and calibration (span and zero) gases.

Note: If the analyzer is equipped with the Auto Calibration feature, input from this screen will override the Auto Calibration status.

To manually change the gas stream sent to the analyzer, press Change Stream from the SETTINGS screen. The following screen will appear:

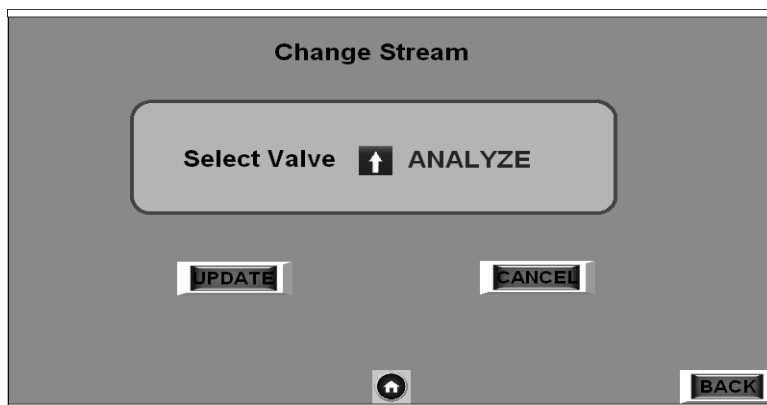

Touch the UP arrow to toggle the display between ANALYZE/SPAN /ZERO. Pressing UPDATE will select the displayed stream and open the corresponding valve. Use CANCEL to abort the selection.

The user can return to the analyze mode by pressing the HOME icon or go back to the SETTINGS screen by touching the BACK button.

4.5.12.4 TIME

The date and time are set from the Time screen. Select Time from the SETTINGS screen.

Touching any of the Date and Time value boxes will bring up a numerical keypad that allows the date and time to be input. The time settings entered in this screen sets the RTC which is interfaced to 9261 board on the I2C interface.

After selecting Time, the following below screen displays:

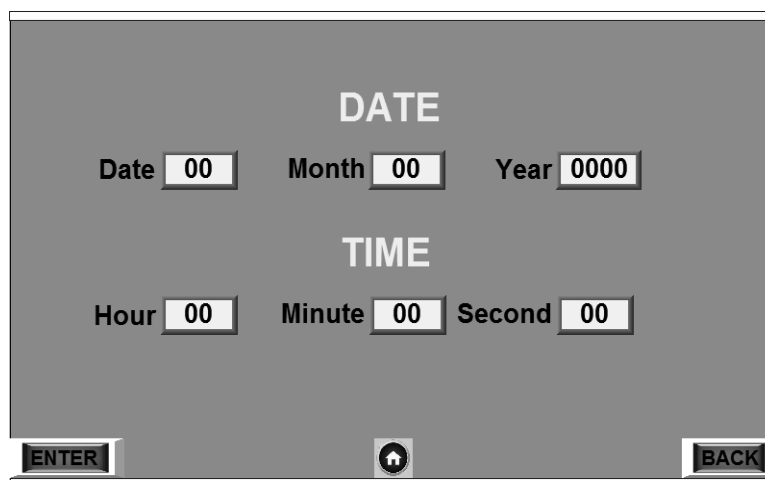

The screenshot shows a grey background with the word "DATE" centered at the top. Below it are three input fields: "Date" with "00", "Month" with "00", and "Year" with "0000". Below these is the word "TIME" centered. Underneath are three input fields: "Hour" with "00", "Minute" with "00", and "Second" with "00". At the bottom of the screen are three buttons: "ENTER" on the left, a home icon in the center, and "BACK" on the right.

After entering each value press the “Enter” button on the keypad to input the number and move to the next field. When all inputs have been made, press the ENTER button on the display screen and then respond to the confirmation display that appears.

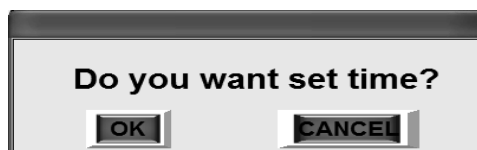

The dialog box has a grey background and a black border. The text "Do you want set time?" is centered. Below the text are two buttons: "OK" on the left and "CANCEL" on the right.

Pressing “OK” saves the new date and time settings.

4.5.12.5 PASSWORD

There are two functions in the GC-Pro TCD that if misused can result in significant changes to the instrument. These are: Default Settings from a Cold Boot (Section 4.5.13.5) and Firmware Upgrade. These functions are therefore password protected functions.

The password is assignable by the user or the default password “11111” can be used. The password can be any number between 1 and 99999.

To assign a new password, press “Password” from the SETTINGS screen. The following screen will appear:



Touching the password box will display a numeric keypad allowing the new password to be entered. Press ENTER on the keypad to dismiss the keypad and insert the new password into the box.

Pressing the HOME icon installs the password and places the analyzer back into the analyze mode. Pressing BACK also installs the new password but returns the display to the SETTINGS screen.

4.5.12.6 COMMUNICATION

There are four different serial communications modes available to the user and these are accessible from the Communications screen.

The available modes are:

- Detect Mode: Used with a laptop computer running custom TAI software and is designed to interact with

the chromatogram screen. (Contact TAI for software upgrade).

- **Query Mode:** A specialized communication protocol that enables interaction with the analyzer via an OPC server.
- **Profi Mode:** This mode is compatible with a Teledyne Valve Box (VB1-VB5) used in switching gas streams to an analyzer.
- **STD Mode:** The standard mode outputs a text string every two seconds that includes concentration, range, and alarm status. If there are multiple components (groups) being analyzed, the output will cycle through each component in sequence.

Press the Communications icon on the SETTINGS screen to enter the communications function.

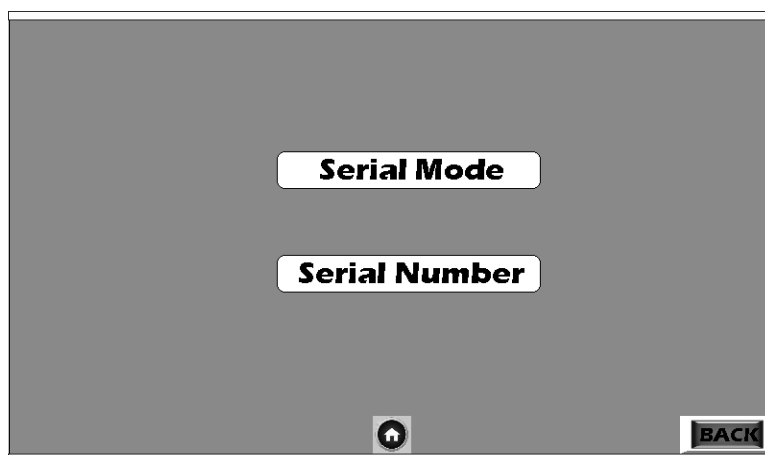

The user can shift between different serial modes by selecting the “Serial Mode” from the above screen and then on the next screen using the UP arrow button, cycle through the modes until the desired mode is presented. Select the mode using the ENTER button.

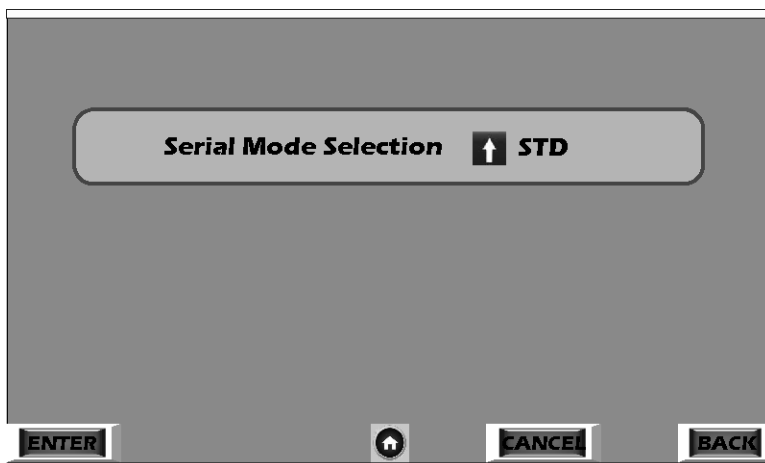

Selecting Serial Number from the Communications Screen produces another screen which allows the user to input the serial number for the analyzer which is used by the RS232 when in Profi mode to identify the analyzer. Use the UP Arrow and then select the ENTER button next to each channel. The following example screen has the analyzer serial number set to 473200. The default serial is 100000.

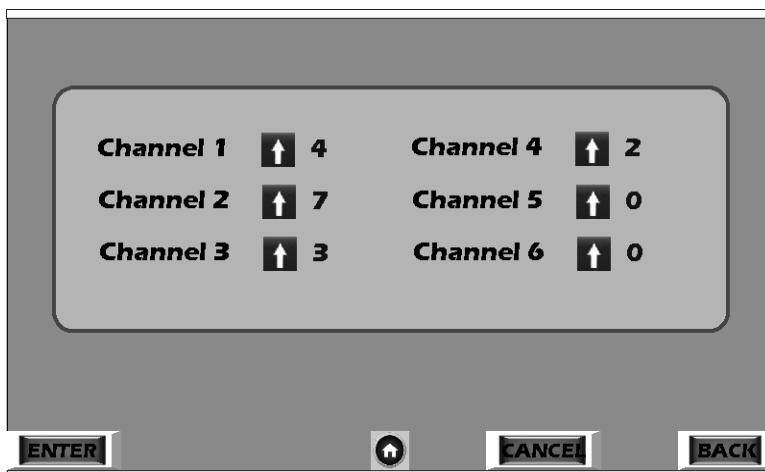

4.5.12.7 DETECTOR

The GC-Pro TCD Analyzer can be equipped with optional detectors at the time of purchase. These options include an FID (Flame Ionization Detector) or SO₂ detector along with the standard TCD detector. If an optional detector has been installed an accompanying addendum will be included to describe the operation and maintenance required for that detector. The DETECTOR function has been set up at the factory for

your specific application and should not be changed from TCD unless directed by TAI Customer Service.

4.5.12.8 SET TCD

With the detector set to TCD, the SET TCD function can be used to adjust for drift on the TCD detector. It has both a coarse and fine adjustment and displays the current ADC count received from the detector.

To make adjustments, press SET TCD from the SETTINGS screen. The following screen appears:

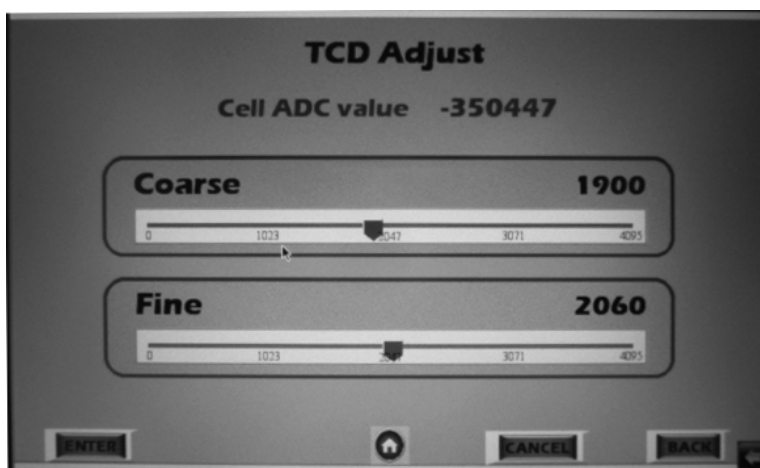

For proper operation, the ADC value should be in the range of 0 to +10,000 counts, preferably, it should be as close to zero as possible. The user can adjust the detector using the coarse and fine adjustment onscreen sliders. After making an adjustment, allow the ADC value to settle before making another adjustment. Often, just a coarse adjustment is adequate, however the value can be fine tuned using the Fine adjustment slider.

The amount of change associated with a FINE adjustment is often very slight and depends on the gain value that is set in the TIMING/PARAMETERS/EDIT screen. See Section 4.5.6.1. The TCD amplifier in the GC-Pro TCD has 10 settings that control the gain of this amplifier. Setting a higher gain value will produce a correspondingly larger change when moving the FINE adjustment slider.

4.5.12.9 CYCLE MODE

The detection cycle can be set for either a continuous measurement cycle or for a single-shot measurement from the CYCLE MODE screen. Although set at the factory for your application, the time allotment for filling the sample chamber in the sample valve can also be set or adjusted with this function.

From the SETTINGS menu, press CYCLE MODE. The following screen appears:

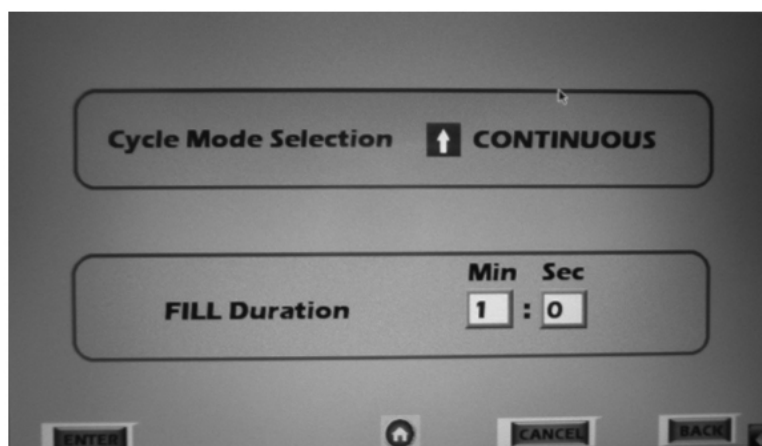

Use the arrow in the Cycle Mode Selection field to toggle between CONTINUOUS and MEASURE ONCE options. Then, if required, you can alter the sample chamber charging time by entering appropriate values in the FILL DURATION field.

Note: This has been set at the factory for your application and should not require alteration. Contact TAI Customer Service before making any changes to this parameter.

As with the other screens, you have the option of cancelling the entry without saving changes using the CANCEL button and/or returning to the previous screen with the BACK button.

4.5.13 Analysis Mode

Analysis mode is the default mode of the instrument where measurements are updated after each cycle (forward + reverse) and displayed on the HOME screen.

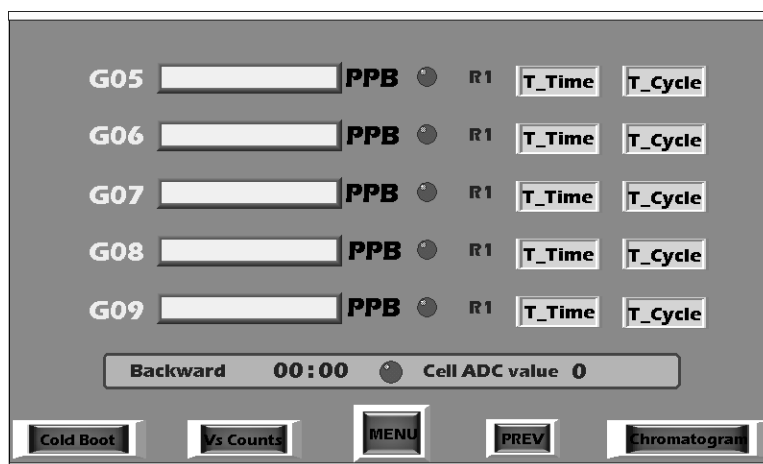
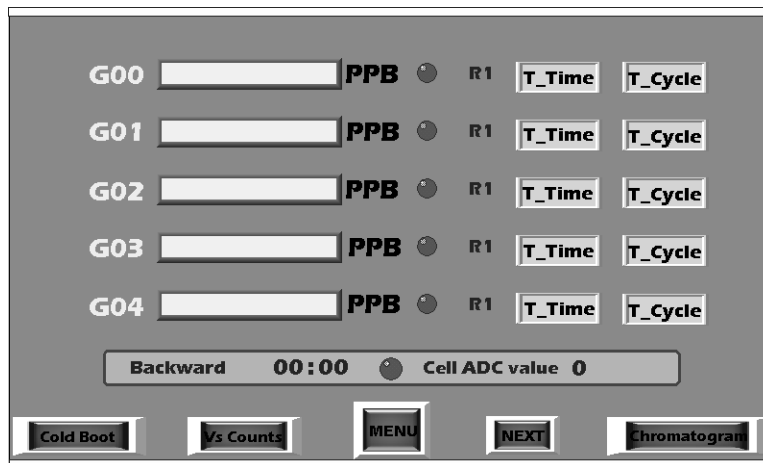

The GC-Pro TCD is analyzing in both the forward and reverse cycles and measurement value integrated over the last complete cycle is shown in the display box adjacent to the group identifier (G00-G09, Bnz, etc.) for any group that has been activated (LED lit). See Group Setup for activating a group. The cycle direction and time into the cycle are shown in the lower box as is the current ADC output value. The current analysis range is indicated next to the Group LED.

4.5.13.1 T-TIME

Each group has “T_Time” and “T-Cycle” selectable buttons associated with it that will bring up a graph displaying the analysis trend

in the group with respect to time or cycle. With these buttons, the user can evaluate the instantaneous analysis as opposed to waiting for a complete cycle to terminate.

The T_Trend screen shows the analysis trend with respect to time.

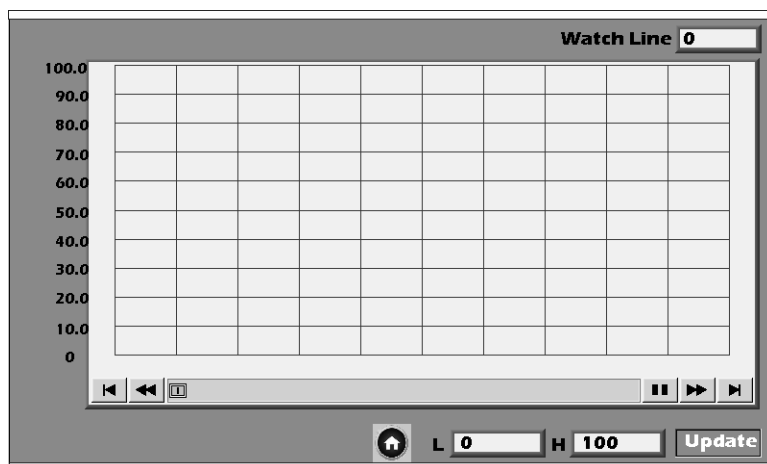

This screen displays the concentration behavior or trend for the group on y axis against the time into the cycle on the x axis.

Low and High values can be set for the y axis using the “L” and “H” boxes below the graph. Touching the “Update” button will reformat the y axis index with the new input.

It is possible to view the instantaneous value by touching the trend graph at the location of interest and the corresponding value will be displayed in “Watch Line” box at the top right corner.

Note: The LOW and HIGH values must be updated by the user as soon as system is powered on.

Note: The trend graph will not be plotted continuously; it needs to be refreshed manually. To refresh the trend screen, press the HOME button to return to the HOME screen and then re-enter the trend screen by pressing trend button.

4.5.13.2 T_CYCLE

Similar to the above function, the T_Cycle button displays a graph of group concentration versus cycles.

The T_Cycle is display is shown below.

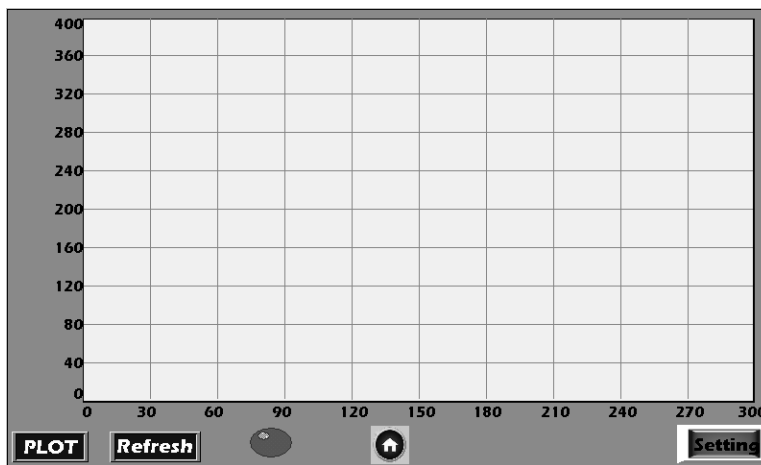

Both X-axis (number of cycles) and y-axis (concentration) can be changed by touching the “Setting” button. The maximum number of cycles that can be plotted is 300.

4.5.13.3 CHROMATOGRAM

The Chromatogram function is available from the HOME screen using the “Chromatogram” button on the lower right corner of the screen. This function displays the ADC count as a function of the number of samples taken (seconds). It is useful for troubleshooting as well as setting up new applications.

Selecting “Chromatogram” from the HOME screen brings up the following screen:

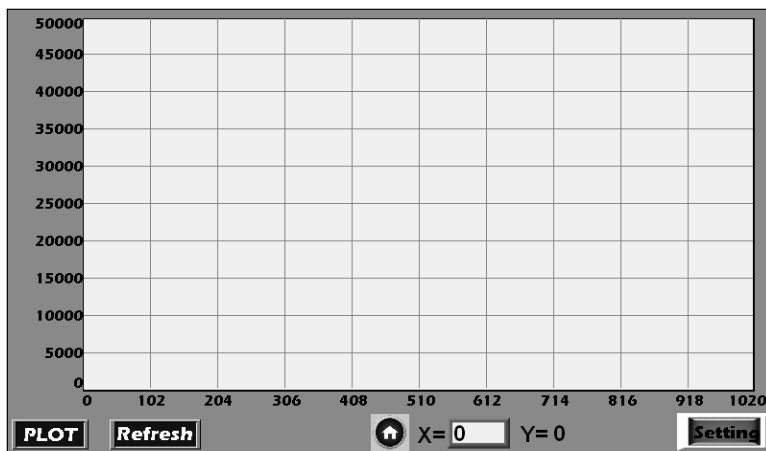

Touching the “PLOT” button will display the graph on the screen and touching the “Refresh” button will clear it. Low and high limits on both the X and Y axis can be changed by touching the “Setting” button. This will cause the following screen to appear:

The figure shows a settings screen for the chromatogram. It has a dark grey background. There are two rounded rectangular boxes side-by-side. The left box is titled 'Calculate X axis' and contains two input fields: 'X - Low' with the value '0' and 'X - High' with the value '0'. The right box is titled 'Calculate Y axis' and contains two input fields: 'Y - Low' with the value '0' and 'Y - High' with the value '0'. At the bottom center, there is a button labeled 'Chromatogram'.

Note: The Chromatogram will be displayed for maximum 1020 samples. The chromatogram will not be displayed if the total sum of the forward and backward phase duration is greater than 1020 seconds.

Note: User can view the Y axis value in digital format by entering the corresponding X axis value in the field provided with X= symbol.

Values for the X and Y axis are entered by touching the input box. A numerical keypad appears that allows for numeric entry. Press ENTER on the keypad to enter the value into the appropriate box and dismiss the keypad. Repeat for each input box requiring an entry or change. Upon final entry, press Chromatogram button to return to the Chromatogram screen. The new X-axis and Y-axis values will be displayed on the screen. The limit for X-High is 1020 i.e., 1020 seconds. So the maximum cycle time which is the sum of the Forward and Backward phase duration should not exceed 1020 seconds (17 min) for the chromatogram.

4.5.13.4 VS COUNT

The VS (Volt-seconds) count is a measure of the conditioned signal coming from the detector. It corresponds to the strength of the output signal from the detector. The VS measure is a relative value and has no absolute relationship to concentration between groups.

4.5.13.5 COLD BOOT

The “Cold Boot” button on the HOME screen provides the user with the option of resuming the system with user configured settings or restoring the analyzer back to the default factory settings for all parameters.

The Cold Boot function is a password protected function. The default password is ‘11111’. If the password has been changed (see Section 4.5.12.5) then the new password must be entered to gain entry into the function that allows a change from the current setting.

Pressing “Cold Boot” from the HOME screen brings up the following screen:

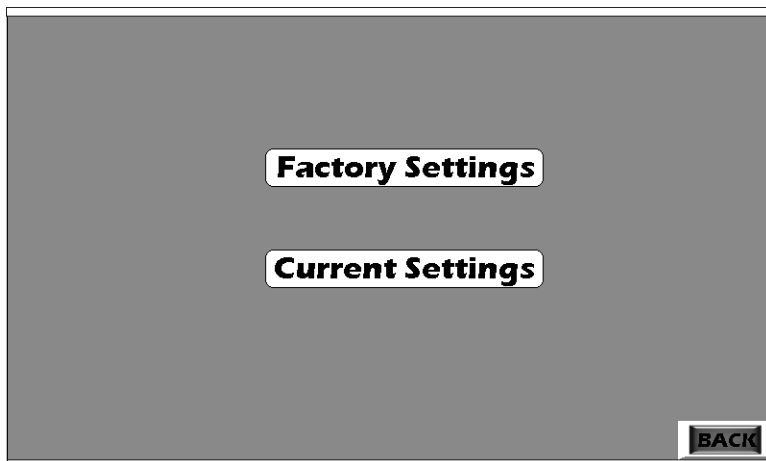

Selecting “Current Setting” causes the analyzer to use all the functions and settings that are presently in force, i.e. no change to the presently saved system configuration. A confirmation window pops up whereby selecting ‘OK” causes the instrument to start up as normal with the present configuration. Pressing “Cancel” reverts the display to the previous screen with no change.



However, if Factory Settings is selected, a Password Entry screen will display requiring the user to input the system password (Default Password is “11111”). After the password is input an “Access Check” pop up window will display requiring the Password to be re-entered. Press “OK” when done.



The validation LED should glow green which means the password has been entered correctly otherwise, the password is incorrect and you will be required to enter it again.

Since this function may drastically alter the settings on the analyzer, once the password has been re-entered correctly and “OK” is pressed, a final Warning screen will appear.



Pressing “OK” will then reset the analyzer to the default configuration with the parameters set as described in Appendix C.

Maintenance & Troubleshooting

WARNING: *DANGEROUS HIGH VOLTAGES EXIST INSIDE THIS INSTRUMENT.*



THERE ARE NO USER SERVICEABLE PARTS INSIDE THE HOUSING OF THE ANALYZER. WORK IN THESE AREAS MUST BE PERFORMED BY AUTHORIZED AND TRAINED PERSONNEL ONLY.



CAUTION: **MANY OF THE ELECTRICAL PARTS WITHIN THE ANALYZER ARE SUSCEPTIBLE TO DAMAGE FROM ELECTROSTATIC DISCHARGE (ESD). USE ESD SAFE PROCEDURES WHEN HANDLING OR WORKING WITH ELECTRONIC COMPONENTS.**



If the analyzer is suspected of incorrect operation, always evaluate performance with span gas flowing in the sample path. Never attempt to evaluate performance on sample gas. If analyzer sensitivity is questionable, use the span gas. For all other evaluations, connect a zero gas and use low range for maximum sensitivity. The important consideration is to control as many variables as possible. Using cylinder-supplied gases of known content eliminates the possibility of introducing an unknown variable.

Do not overlook the seemingly obvious. Check to see that power is available for the instrument (and of the proper voltage, etc.), and that connections are correct. Also verify that support/calibration gases are not depleted.

Appendix

A.1 Specifications and Initial Settings:

Range(s):	Refer to Addendum and Testing Results in Appendix C.
Power Requirements:	Refer to Addendum and Testing Results in Appendix C.
Signal Output:	Ten assignable 4-20 mA DC analog channels with Channel 0 and Channel 2 having gain and offset capability. Channel 0 equipped with Wave Function for ADC count display. User configurable as: Benzene, other aromatics, inert gases, etc. with assignable peak traces.
Alarms:	Two Concentration Alarm 'C' Type relay contacts. User configurable. One System Alarm for AC power failure and flame out, fail safe, 'C' type relay contacts.
Calibration Contact:	Calibration Contact, 'A' Type Relay contact for span mode indication.
RS-232 Output:	Four selectable RS-232 modes
Ambient Temp:	0 – 40° C. Install in a well ventilated area

A.2 Recommended Spare Parts List

Qty.	P/N	Description
1	B74671A	PC board, Flame guard & anode power supply
1	B79153A	PC board, Electrometer
1	B84337A	Micro-processor PC board
1	B84389A	9261 Controller PCB
1	B84392A	Back Panel/Power Supply PCB
1	B84385A	Heater Controller PCB
1	B84371A	Signal Conditioning PCB
1	B84349A	Analog DAQ PCB
1	B82773	TCD Sensor Assy.
1	F77	Fuse, 6.25A (3 AG)
1	B85634A	10 Port Switching Valve with Actuator,

IMPORTANT: Orders for replacement parts should include the part number and the model and serial number of the system for which the parts are intended.

Send orders to:

TELEDYNE ELECTRONIC TECHNOLOGIES

Analytical Instruments

16830 Chestnut Street
City of Industry, CA 91748

Telephone: (626) 934-1500
Fax: (626) 961-2538

Web: www.teledyne-ai.com
or your local representative.

Web: www.teledyne-ai.com
or your local representative.
Email: ask_tai@teledyne.com

A.3 Drawing List

(Refer to the *Addendum and Testing Results* section of Appendix C for actual drawing list for your application.)

D82772	Piping Diagram
D89442	Outline Drawing
D86107	Wiring Diagram

Appendix B

B1. VNC for GC-Pro TCD

To gain access to the GC Pro TCD remotely over a VNC connection you must enable the VNC function on the GC Pro display settings. To do this, follow the instructions below.

1. Power up GC-Pro TCD and connect an Ethernet cable from the router to the back of the GC-Pro TCD.
2. Touch the arrow icon on the lower right-hand corner of the screen.



3. More icons will appear, press the gear icon that appears on the bottom taskbar.

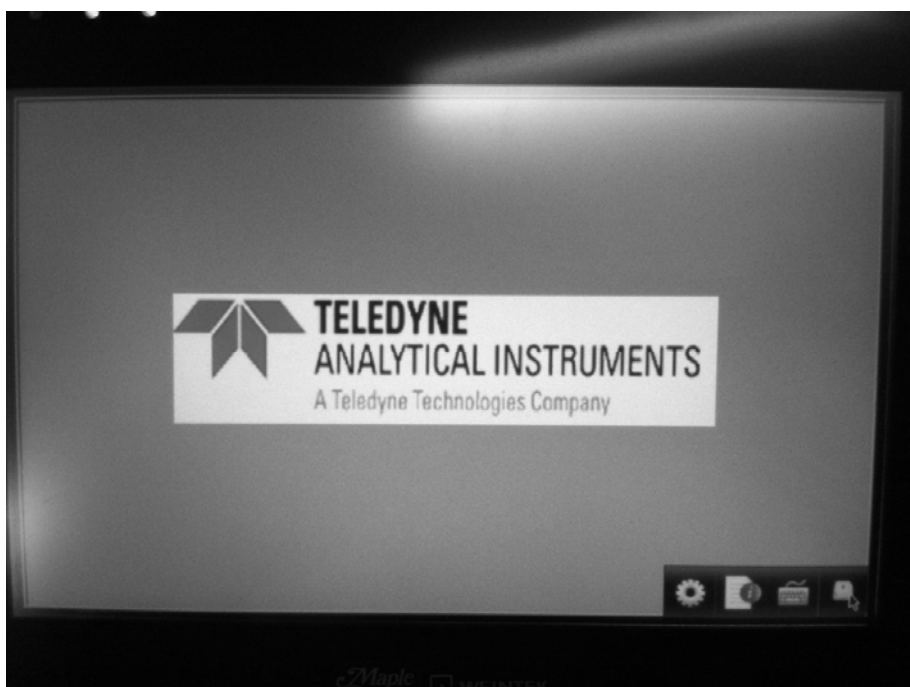

4. A password will be requested. Enter the default password 111111 using the touch screen keyboard.

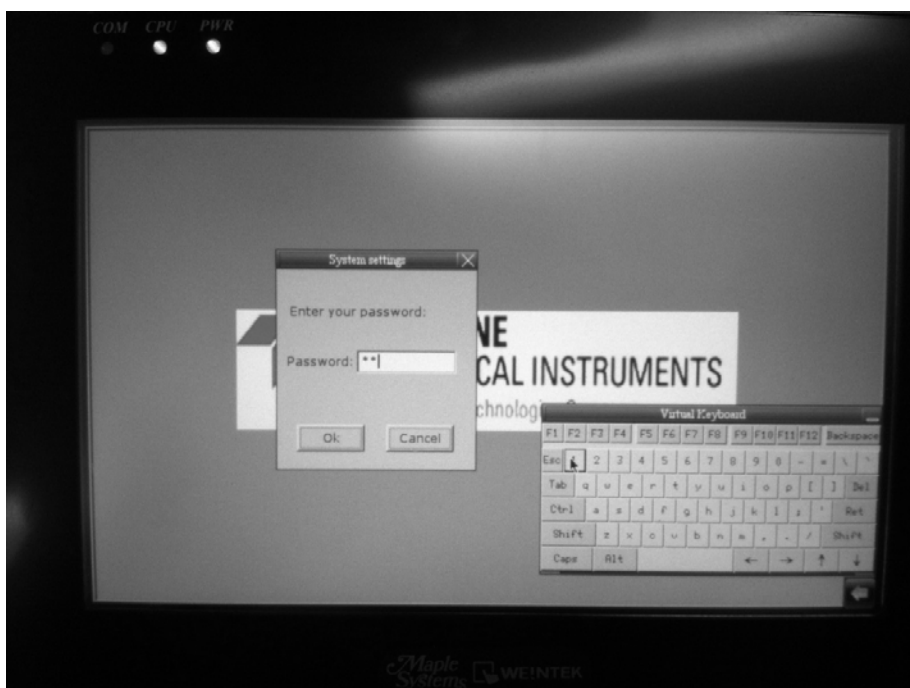

5. A new pop up window will appear. Select the Network tab, select 'IP address select from below' and enter the IP address desired on the now editable fields. Press the apply button.

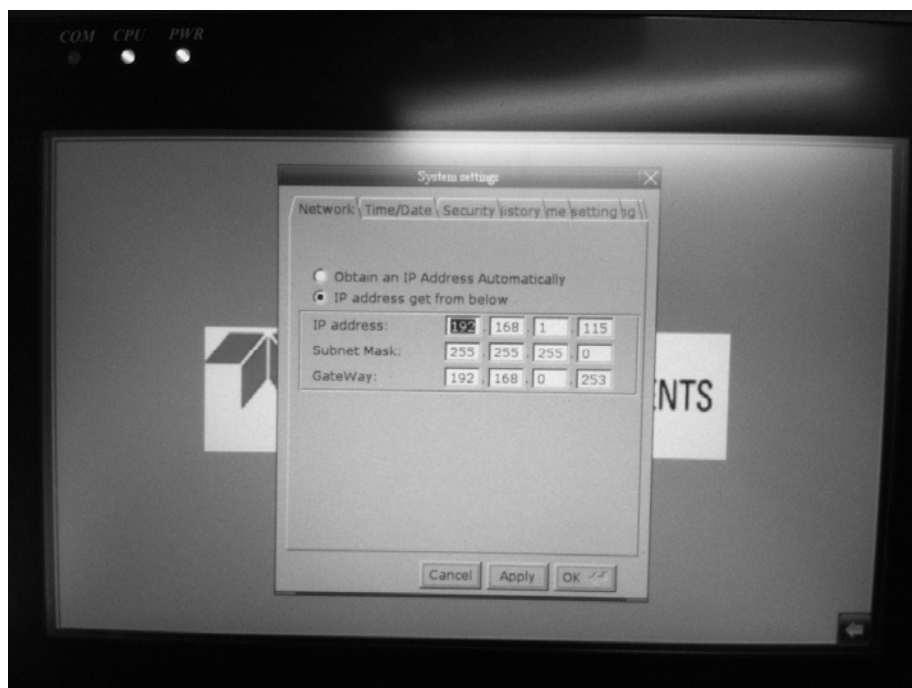

6. Select the 'VNC Server setting' tab. This tab can be hard to see. It may appear as a tiny sliver or partially covered by other tabs. Press the 'Start VNC' button and then the 'Apply' button.

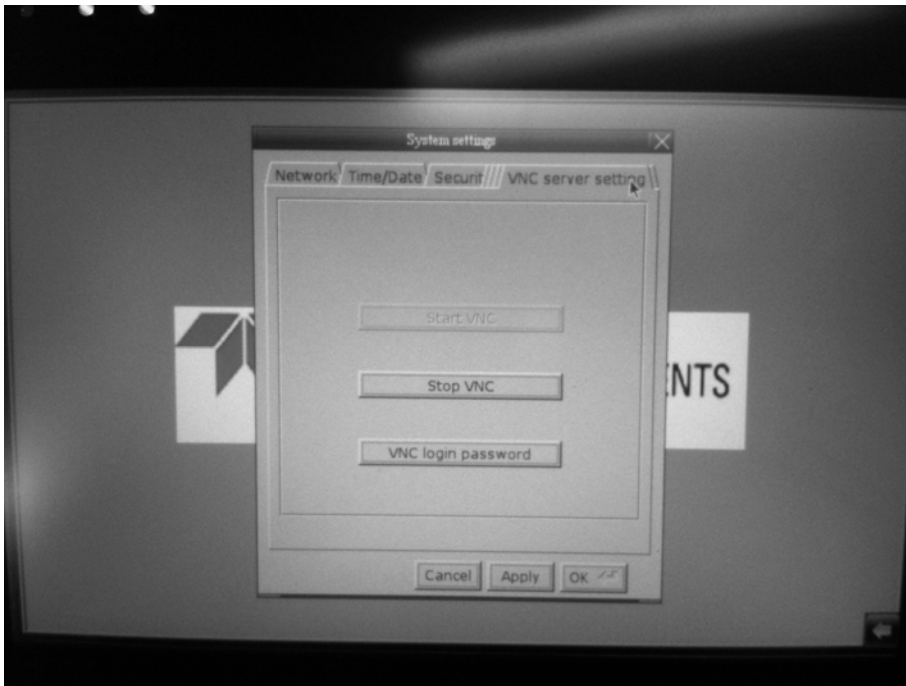

7. Close the pop up windows by pressing the 'X' button on the top right corner of the pop up window. The GC Pro TCD is set for VNC and ready.
8. Now install a VNC application on your computer or ipad/tablet that connects to the same network as the GC Pro TCD. A VNC application is a third party software not developed by TAI. A quick search over the internet will offer many of those applications by different developers. TAI has tested 'Real VNC' with success. Their website is at: <http://www.realvnc.com/>

TAI, however, is not responsible nor able to provide any support for these products. See the picture below of an ipad that has the VNC viewer application installed. The ipad is connected to the network through wi-fi.



9. Enter the IP address for the GC Pro TCD, and enter a name so that it is saved with that name, then connect. If you are prompted to enter a password, enter same default password 111111.



10. VNC app should now be connected to the GC Pro TCD.
Whatever screen shows on the GC Pro TCD should also display on the VNC app and you can control it remotely.

Note: There is a small cursor that you must drag to the icon or button you want to press, thus operation is by dragging a mouse cursor and then pressing, not like an ipad/tablet touchscreen.

Appendix C

C1 Addendum and Testing Results

NOTES: UNLESS OTHERWISE SPECIFIED.

REVISIONS			
REV.	DESCRIPTION	DATE	APP. BY
0	INITIAL RELEASE	04/20/09	KN
1	MOVED MINI-REGULATOR	09/03/09	EY
2	ADDED MINI-REGULATOR BEFORE FLOW CONTROLLER	09/17/09	EY
3	REVISE PIPING	07/03/12	KN
4	WAS: FLOW CONTROL IS: DELETED WAS: MINI REG IS: REGULATOR 0-15 PSIG	05/19/14	PH

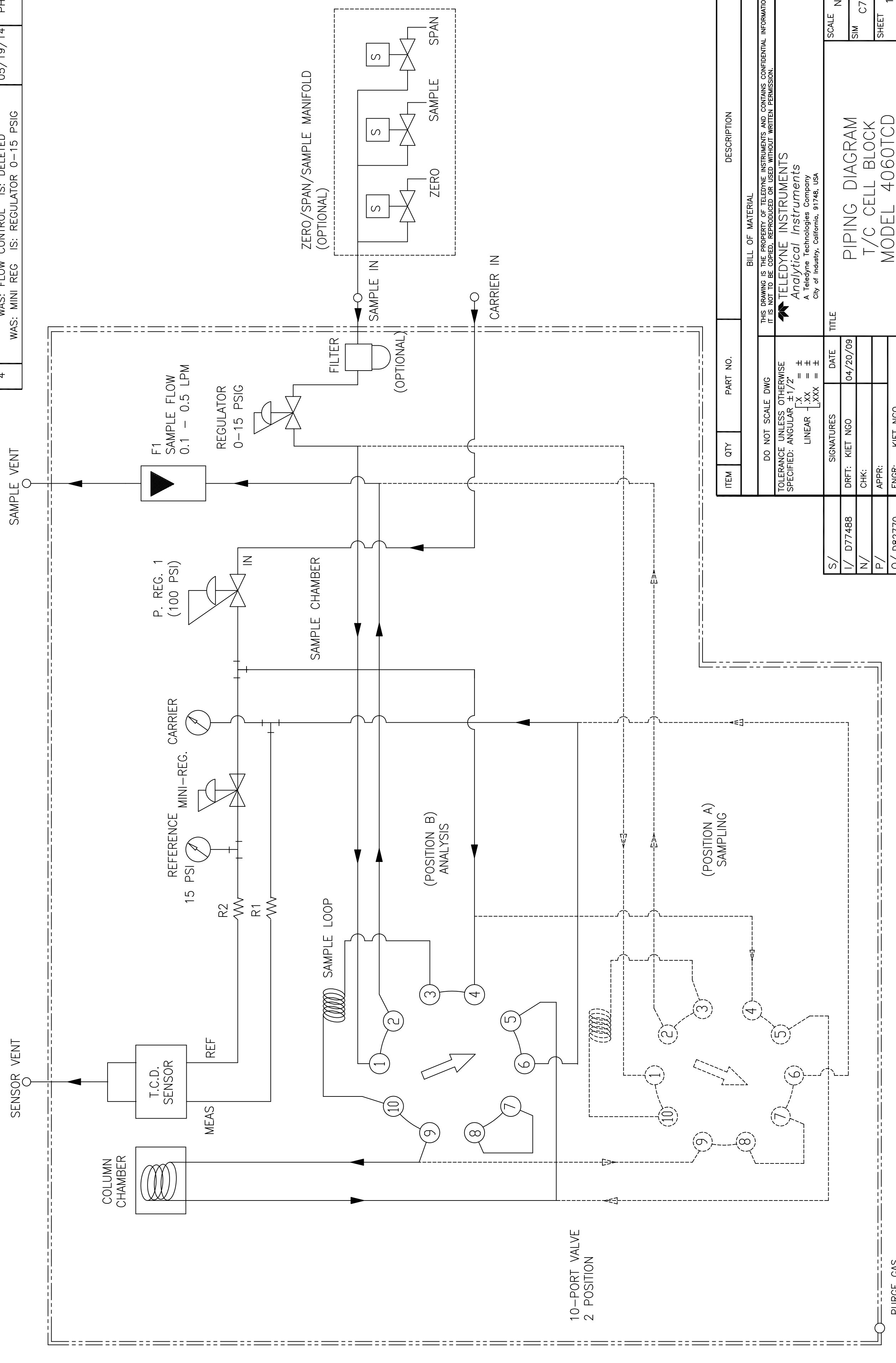

ITEM	QTY	PART NO.	DESCRIPTION
BILL OF MATERIAL			
DO NOT SCALE DWG TOLERANCE UNLESS OTHERWISE SPECIFIED: ANGULAR ±1/2 LINEAR ±.XXX ±.1			
S/			
I/	D77488		DRFT: KIET NGO
N/			CHK:
P/			APPR:
O/	D82770		ENGR: KIET NGO
F/	D82771		C.O. 119741
REFERENCE			CAD ID C82772-4
SIGNATURES		DATE	TITLE
		04/20/09	
SCALE		NONE	
SIM		C76068	
SHEET		1 OF 1	
REV		4	
DWG NO.		C-82772	
MATERIAL		NONE	
TITLE		PIPING DIAGRAM T/C CELL BLOCK MODEL 4060TCD	

TELEDYNE INSTRUMENTS
Analytical Instruments
A Teledyne Technologies Company
City of Industry, California, 91746, USA

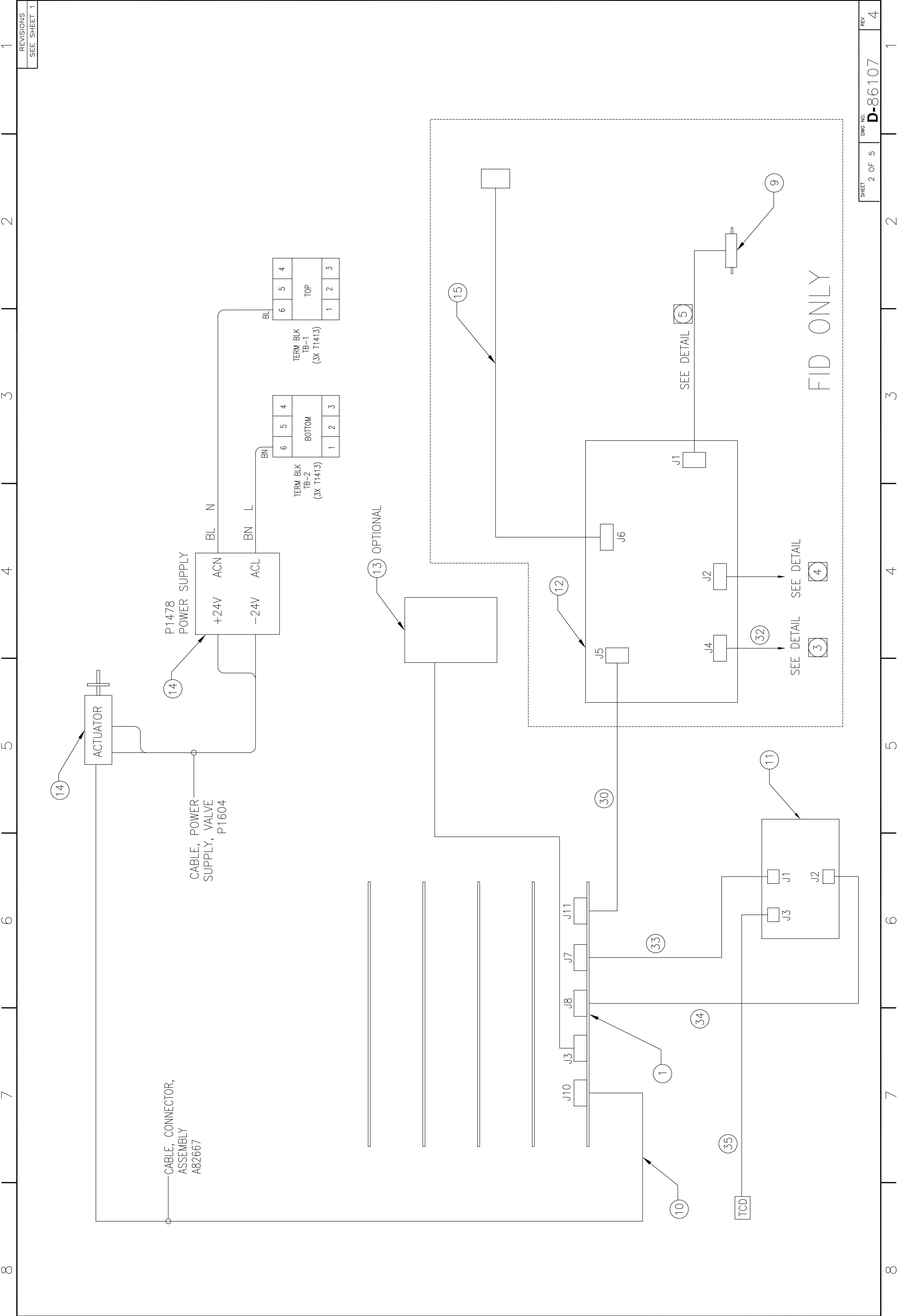

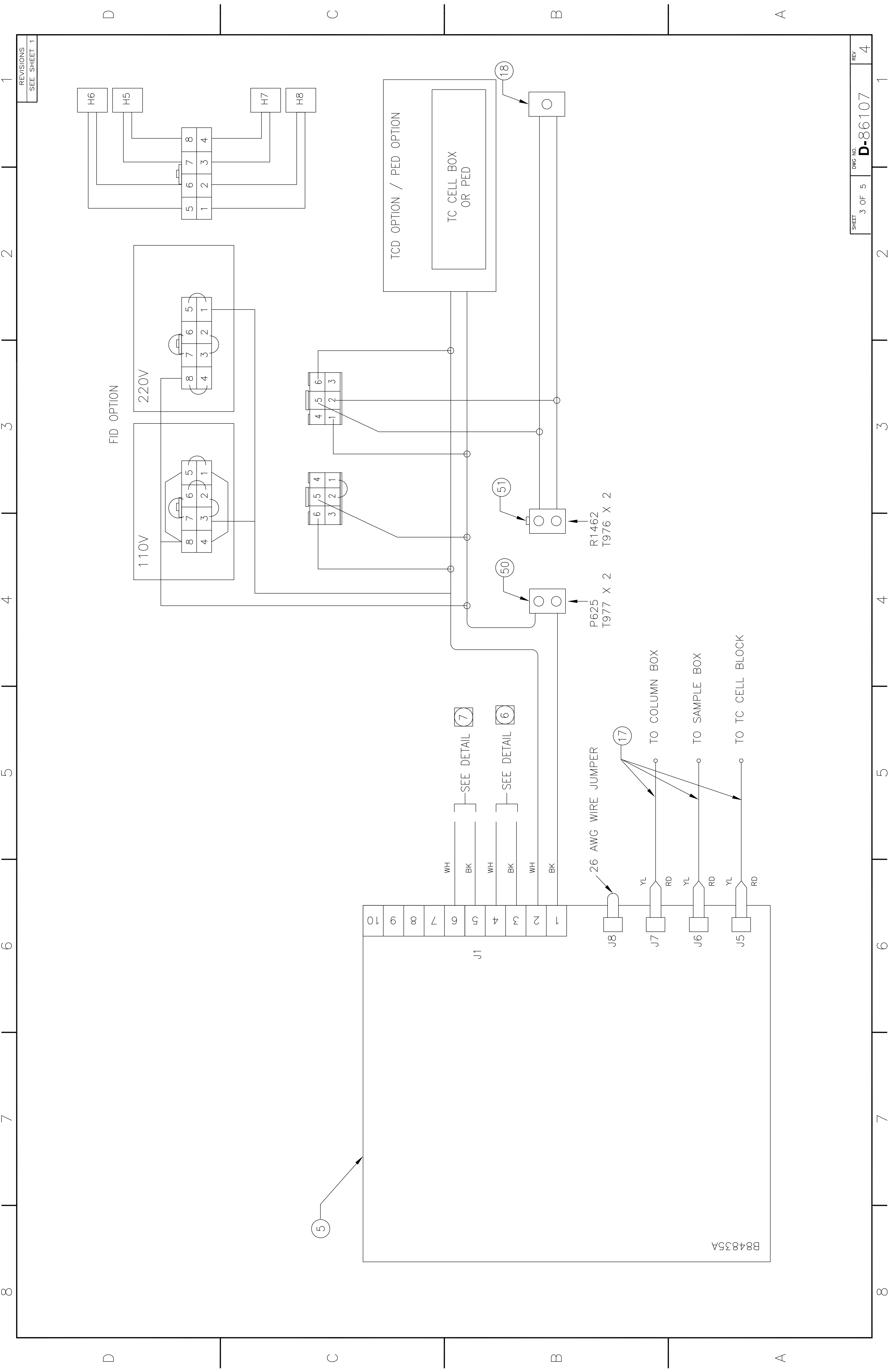

REVISIONS
SEE SHEET 1

SHEET 3 OF 5
DWS NO. D-86107
REV. 4

B84835A

REVISONS
SEE SHEET 1

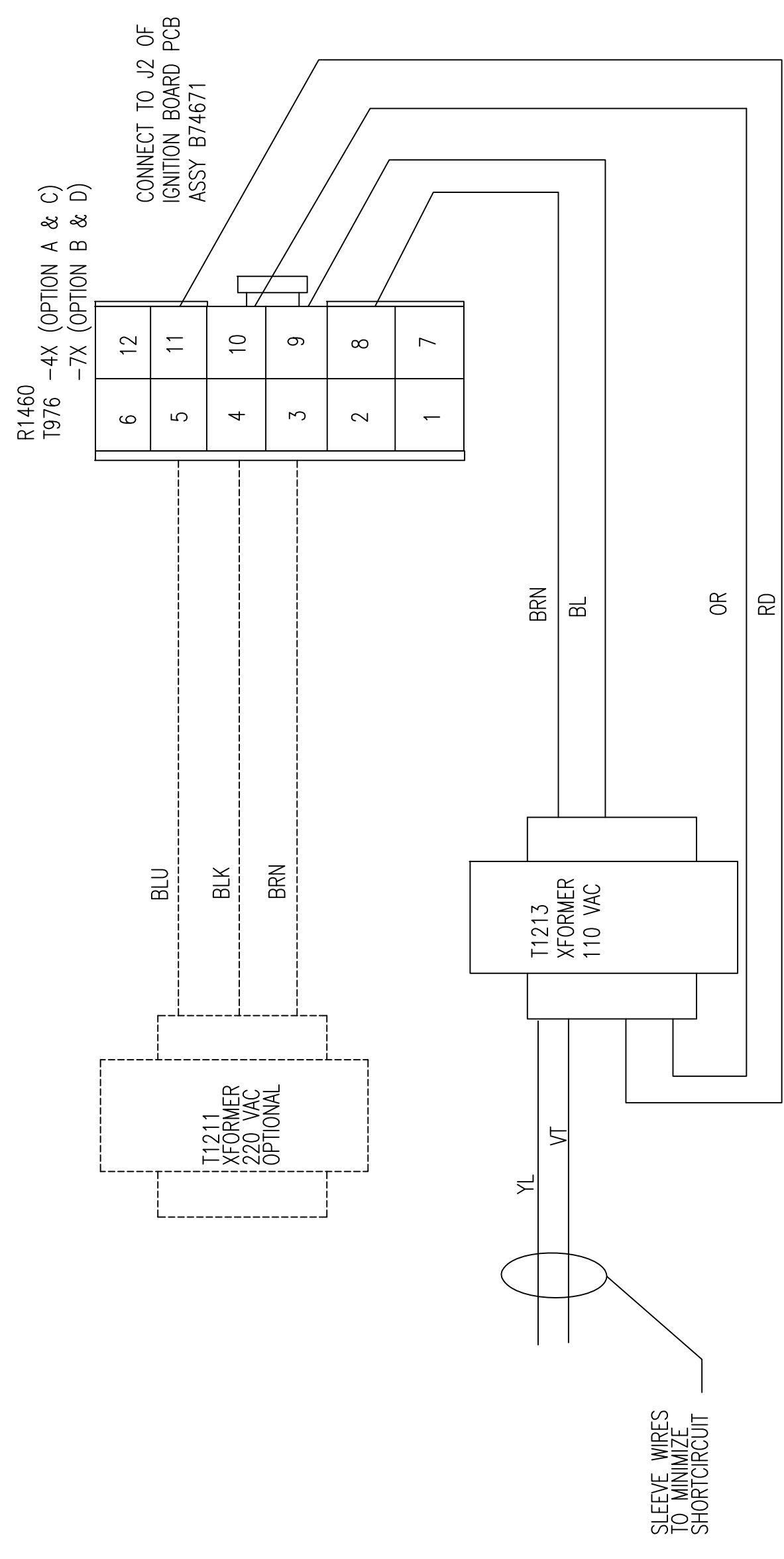

DETAIL 4
FID ONLY

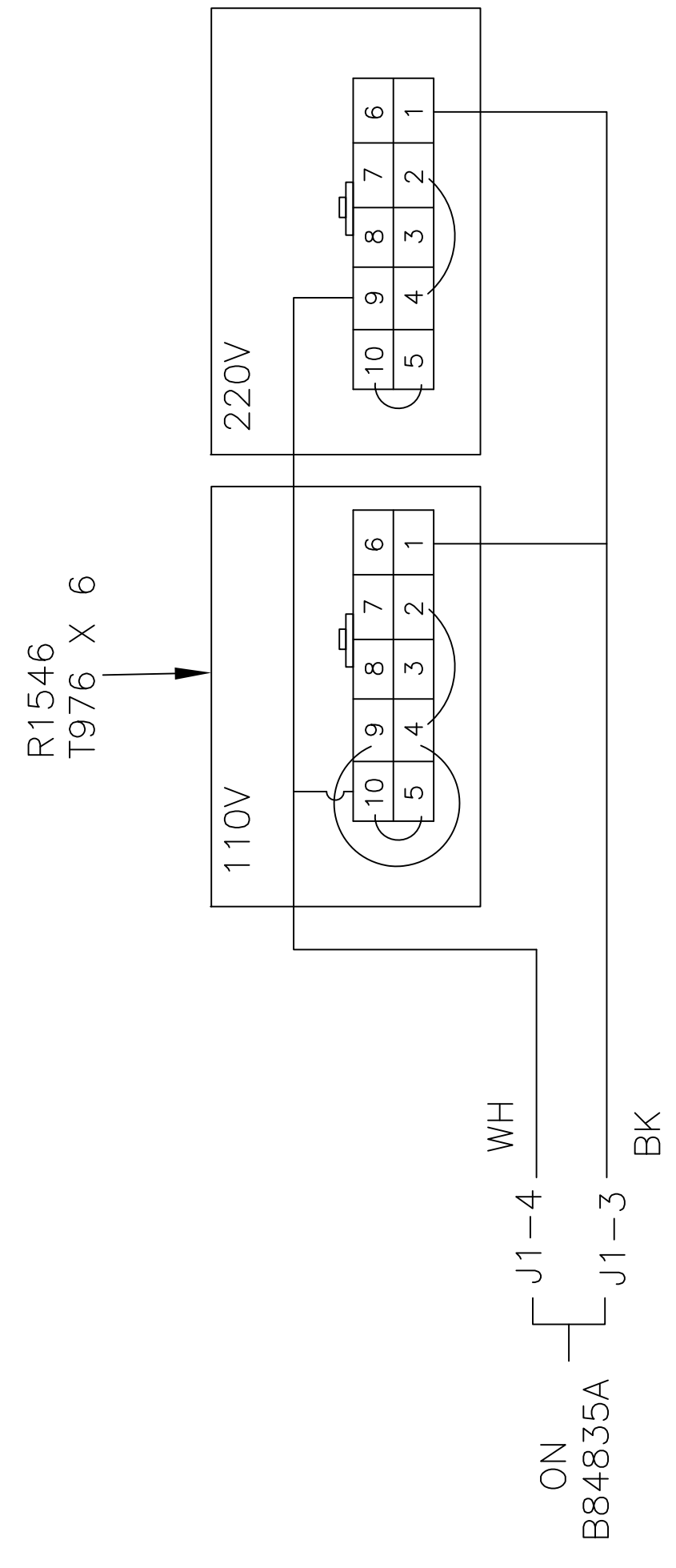

DETAIL 6

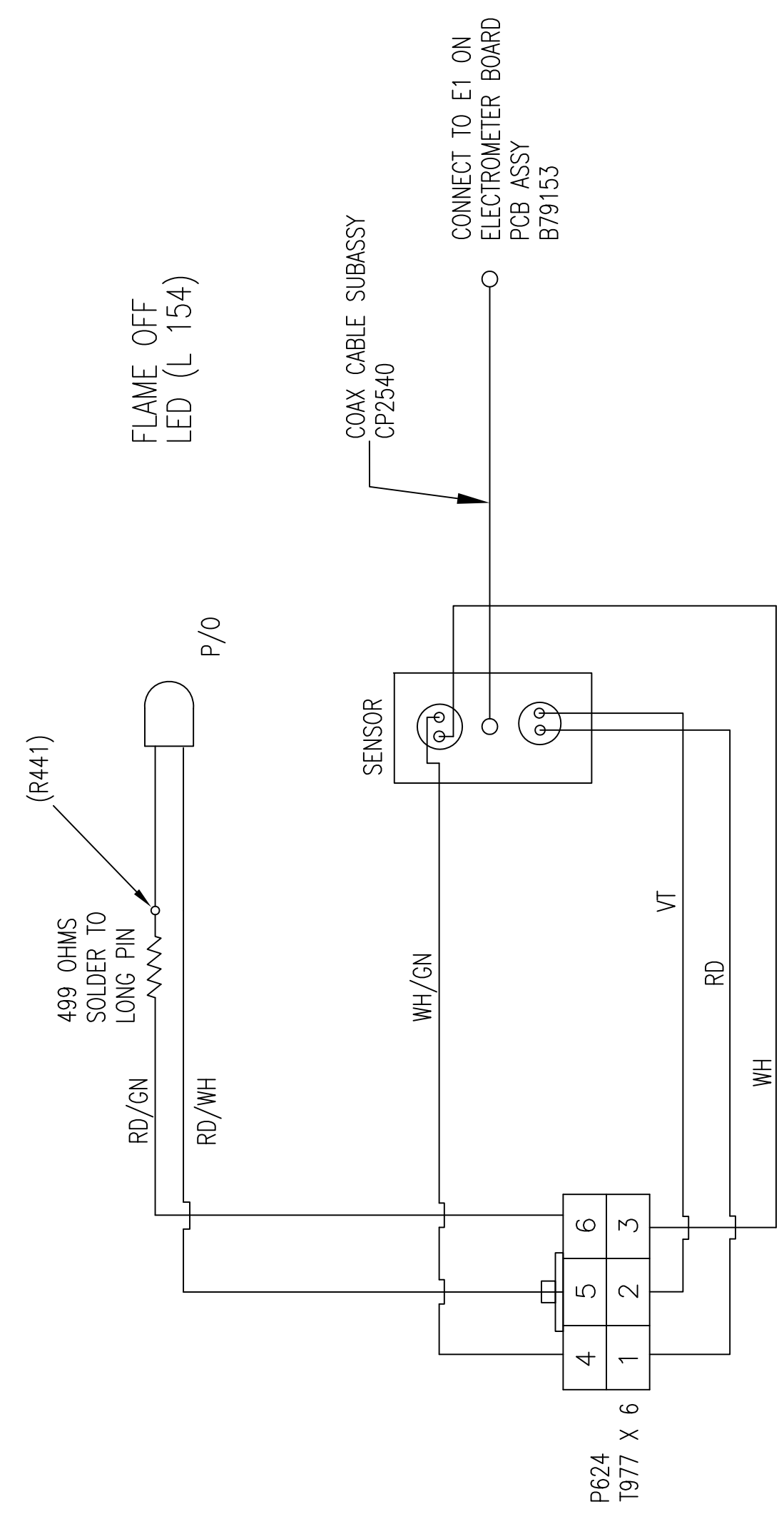

DETAIL 3
FID ONLY

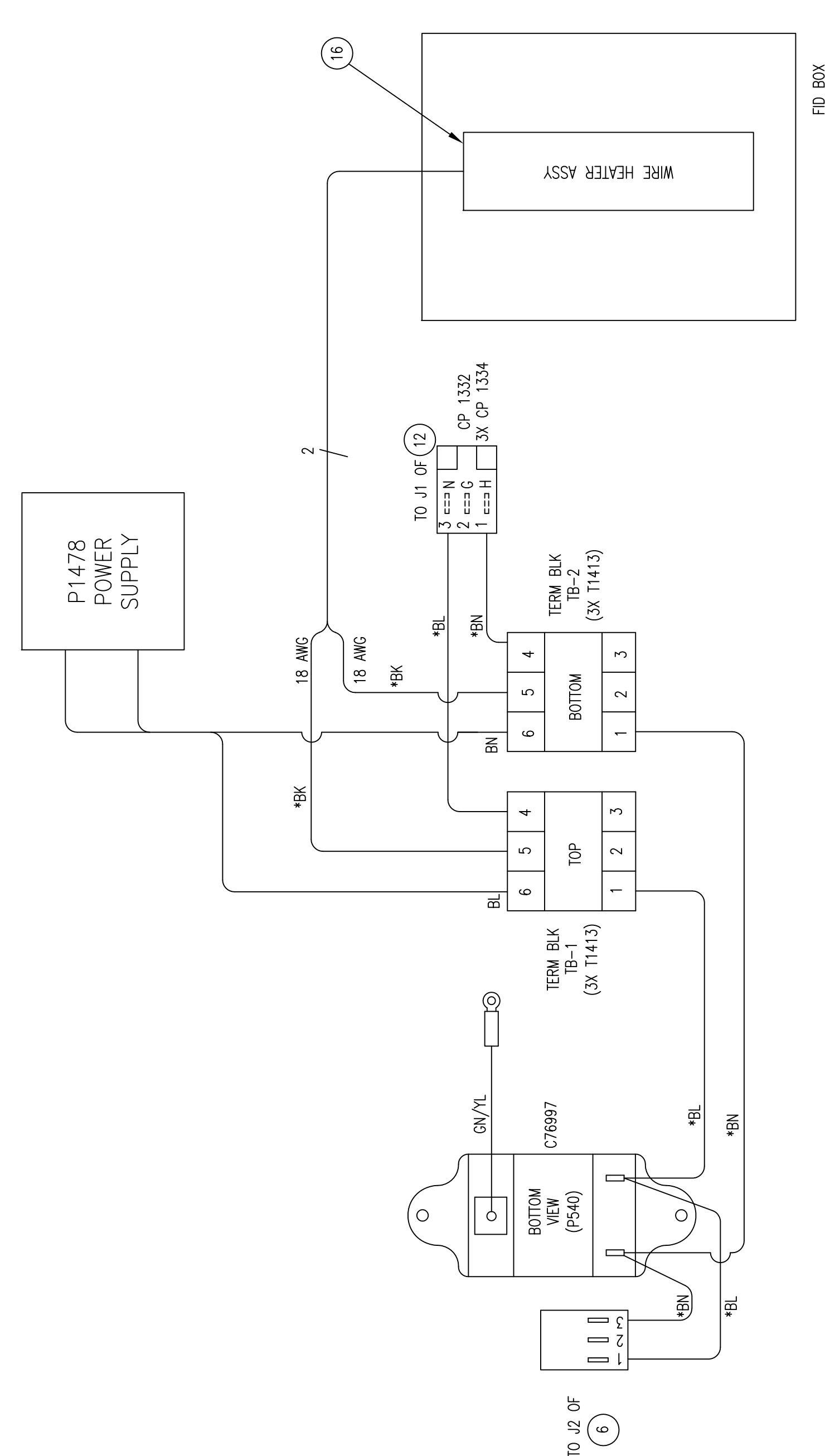

DETAIL 5

D

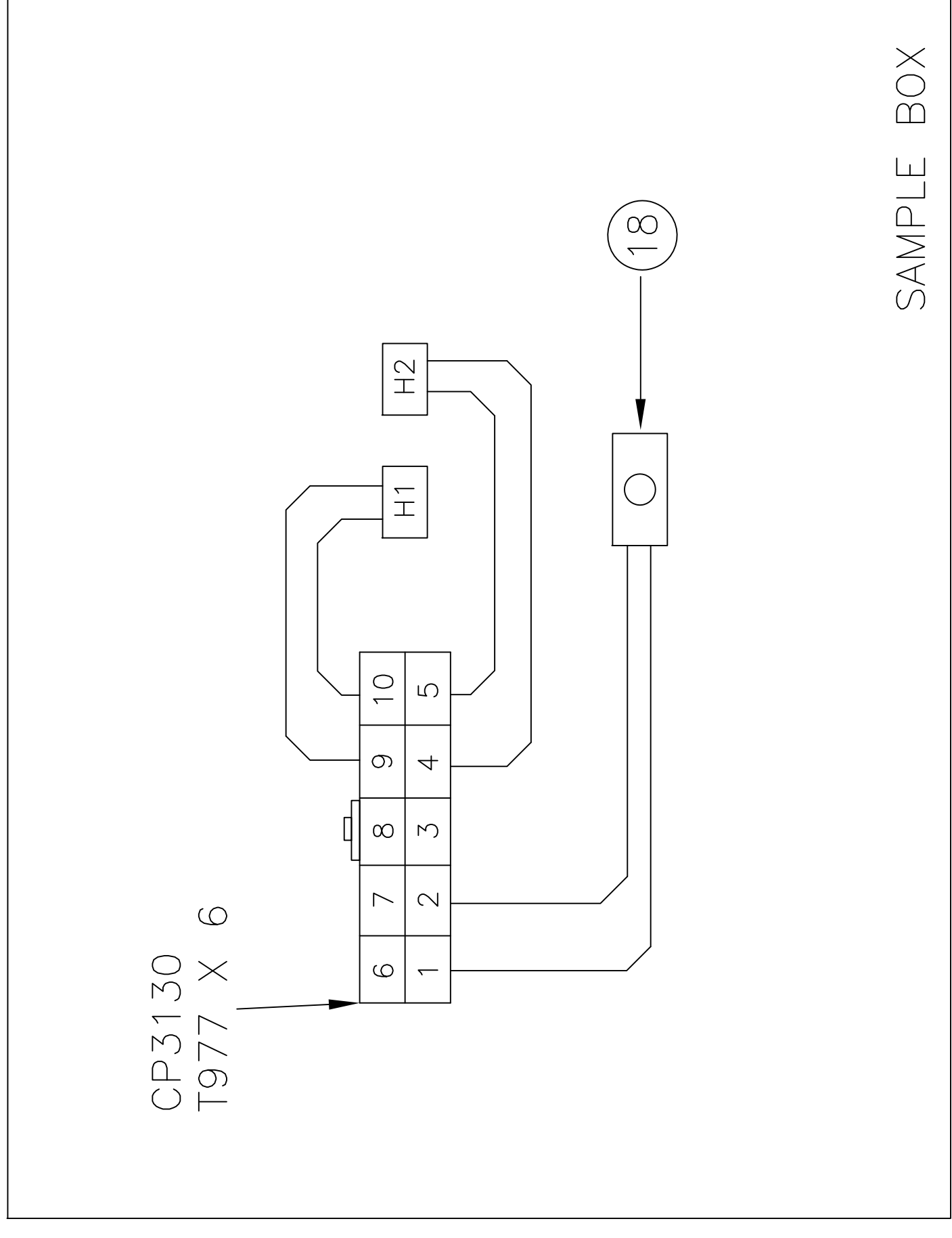

SAMPLE BOX

D

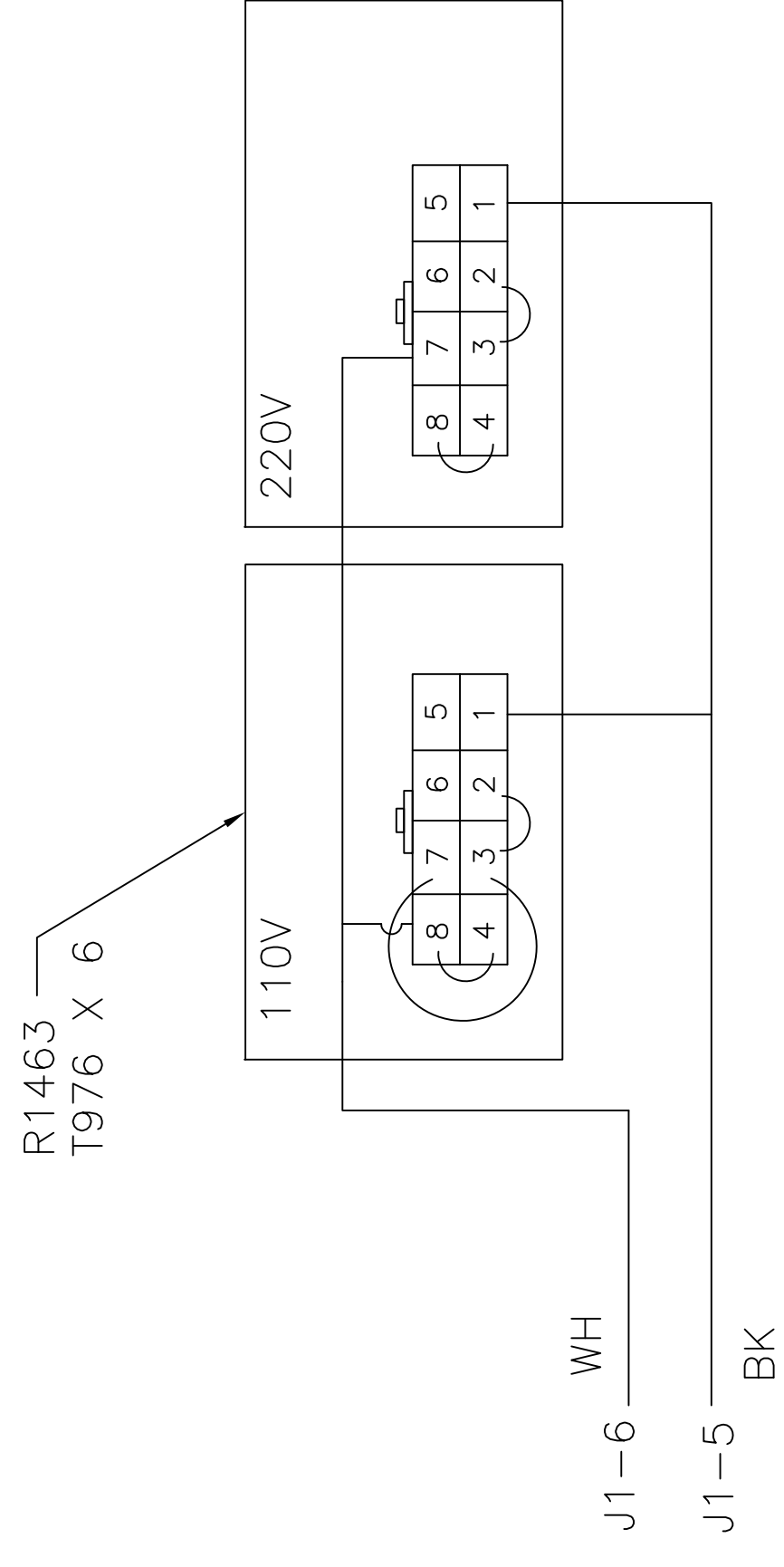

DETAIL 7

NOTE: WIRE METHANIZER AS PER 110VAC OPTION USE H1 (HEATER) ONLY.

C

B

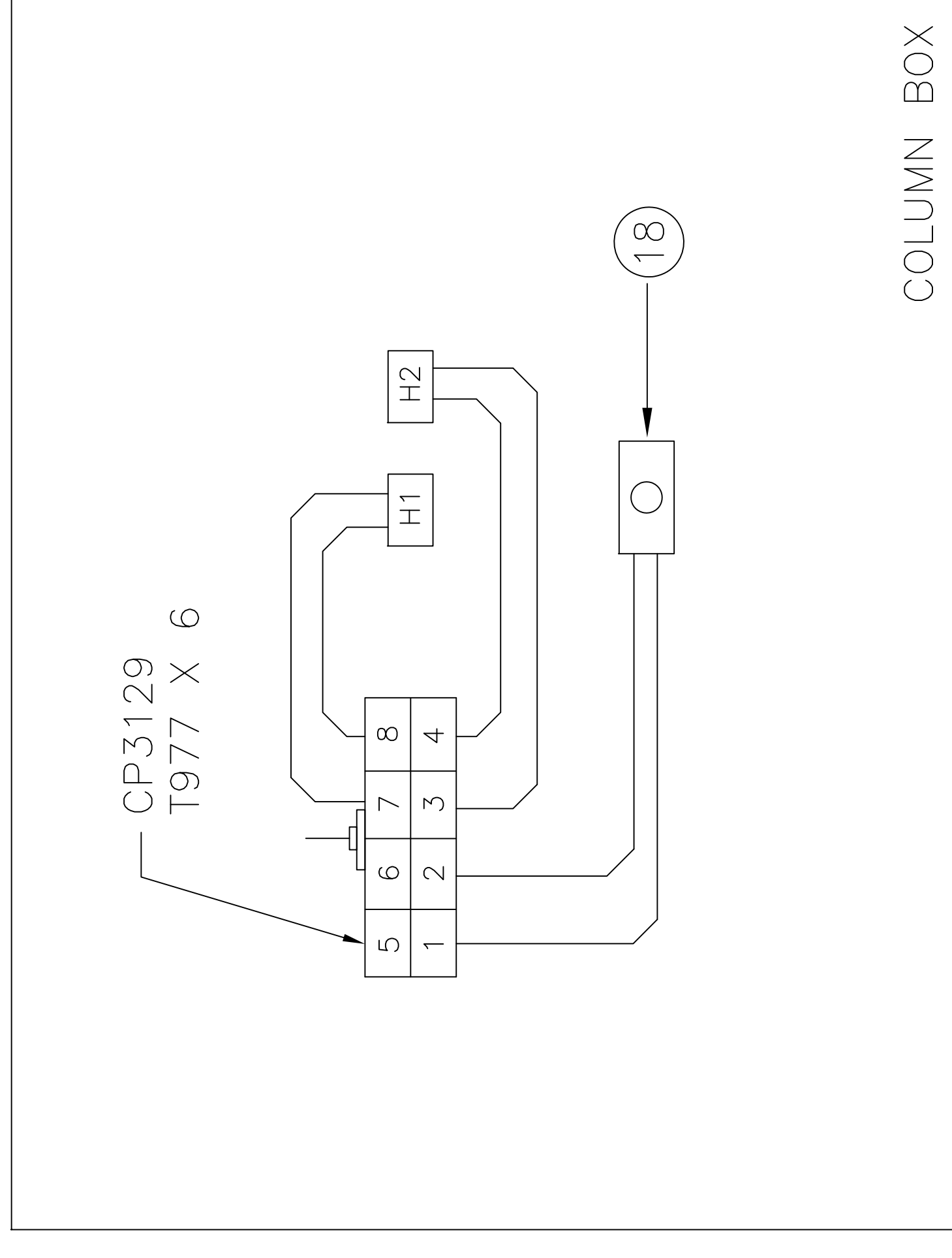

COLUMN BOX

B

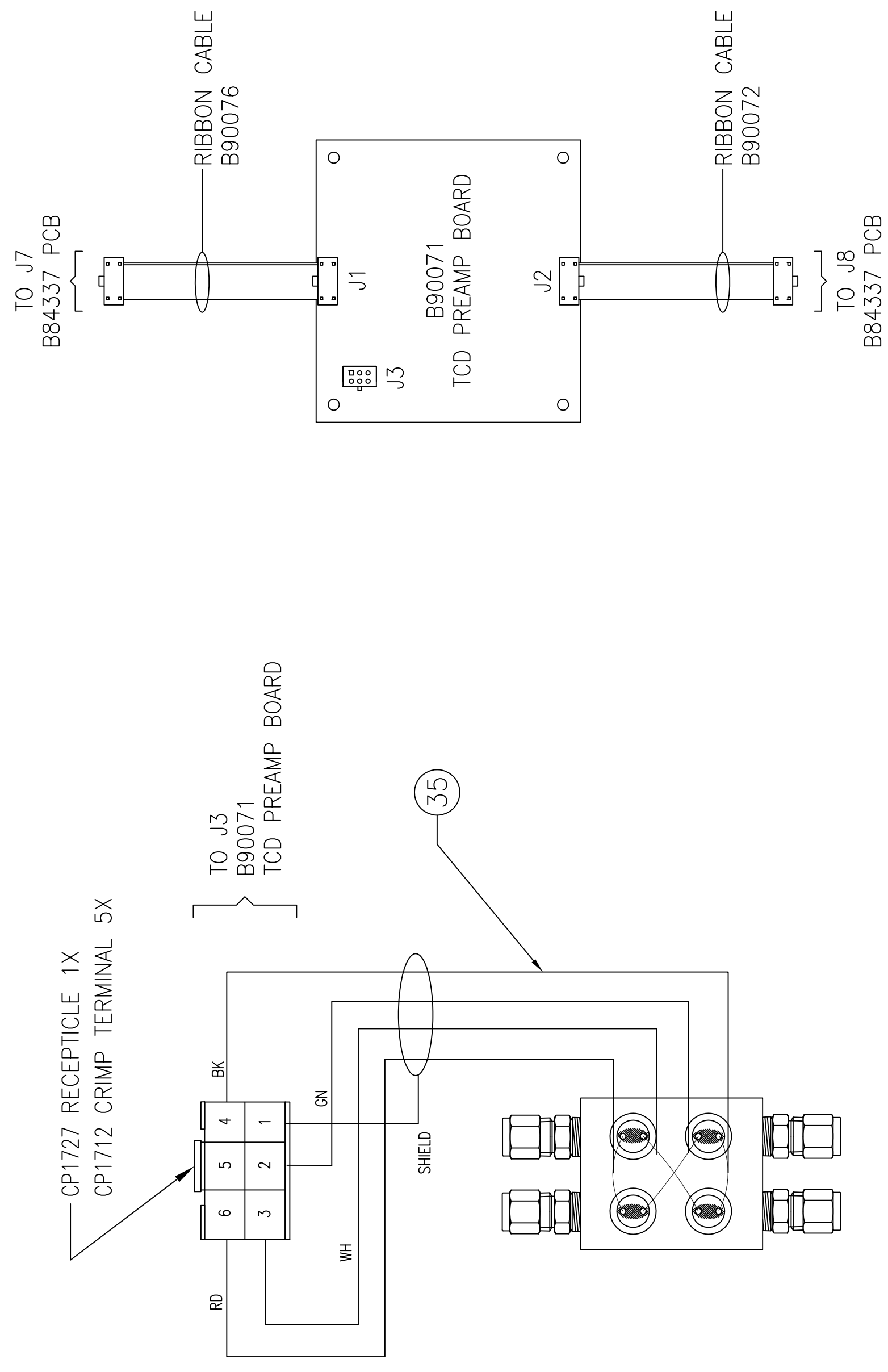

TCD OPTION

A

REVISIONS	SEE SHEET 1
-----------	-------------

- NOTES: UNLESS OTHERWISE SPECIFIED.
- INPUT/OUTPUT DATA CONNECTIONS:
RS232: 9 PIN DSUB CONNECTOR
CONTROL DATA: 50 PIN DSUB CONNECTOR.
 - ALL DIMENSIONS ARE IN INCHES [MILLIMETERS]
- 3] AUTOCAL VALVE MANIFOLD: OPTIONAL FEATURE.

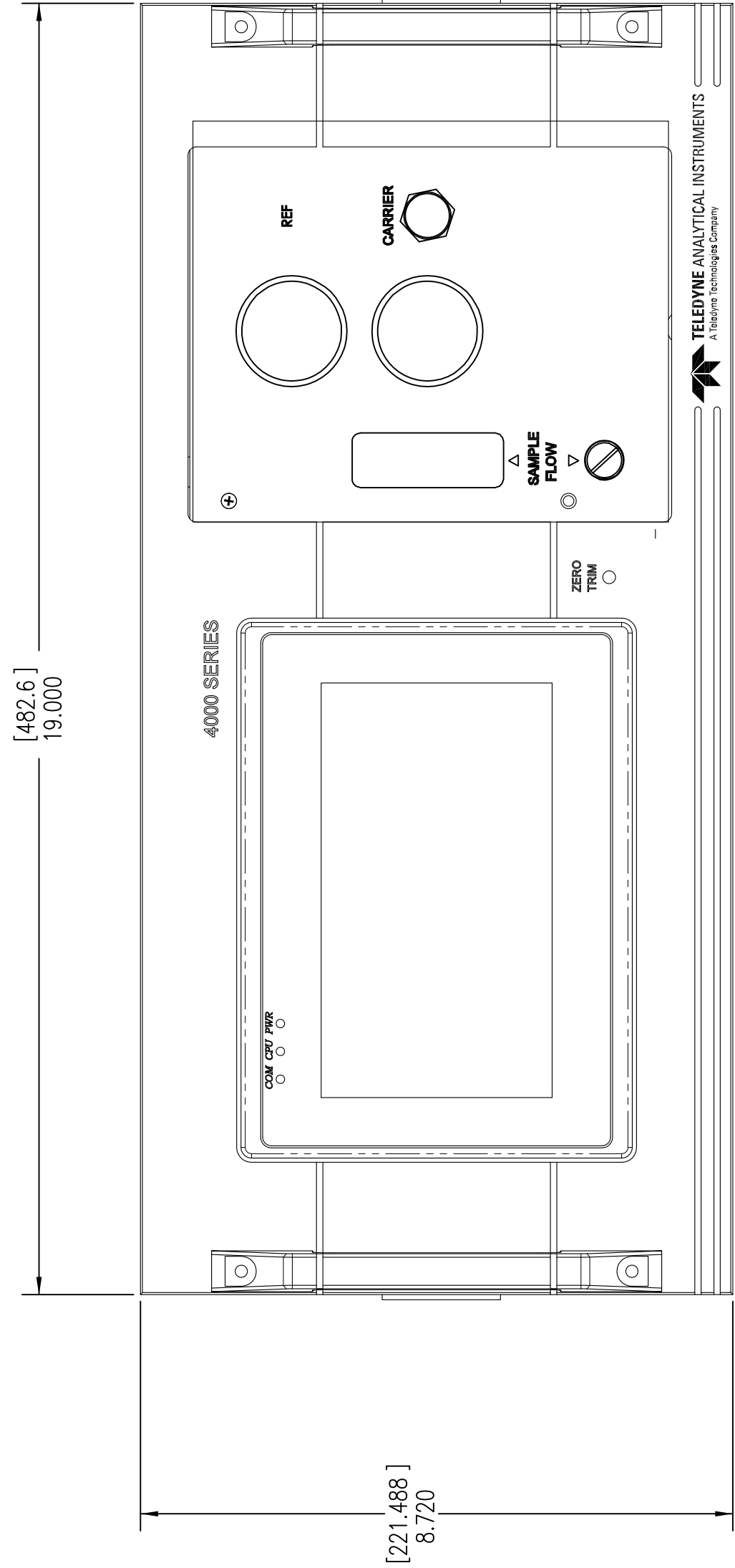

FRONT VIEW

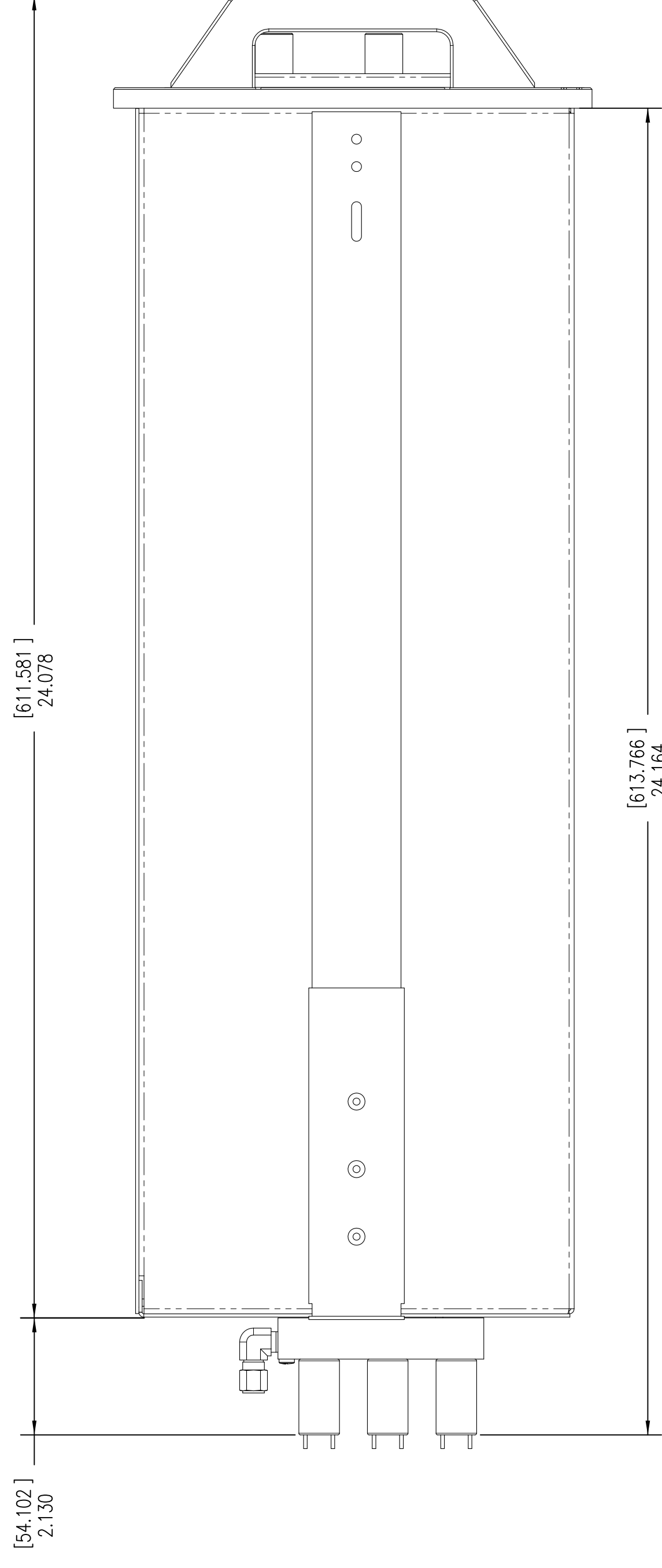

SIDE VIEW

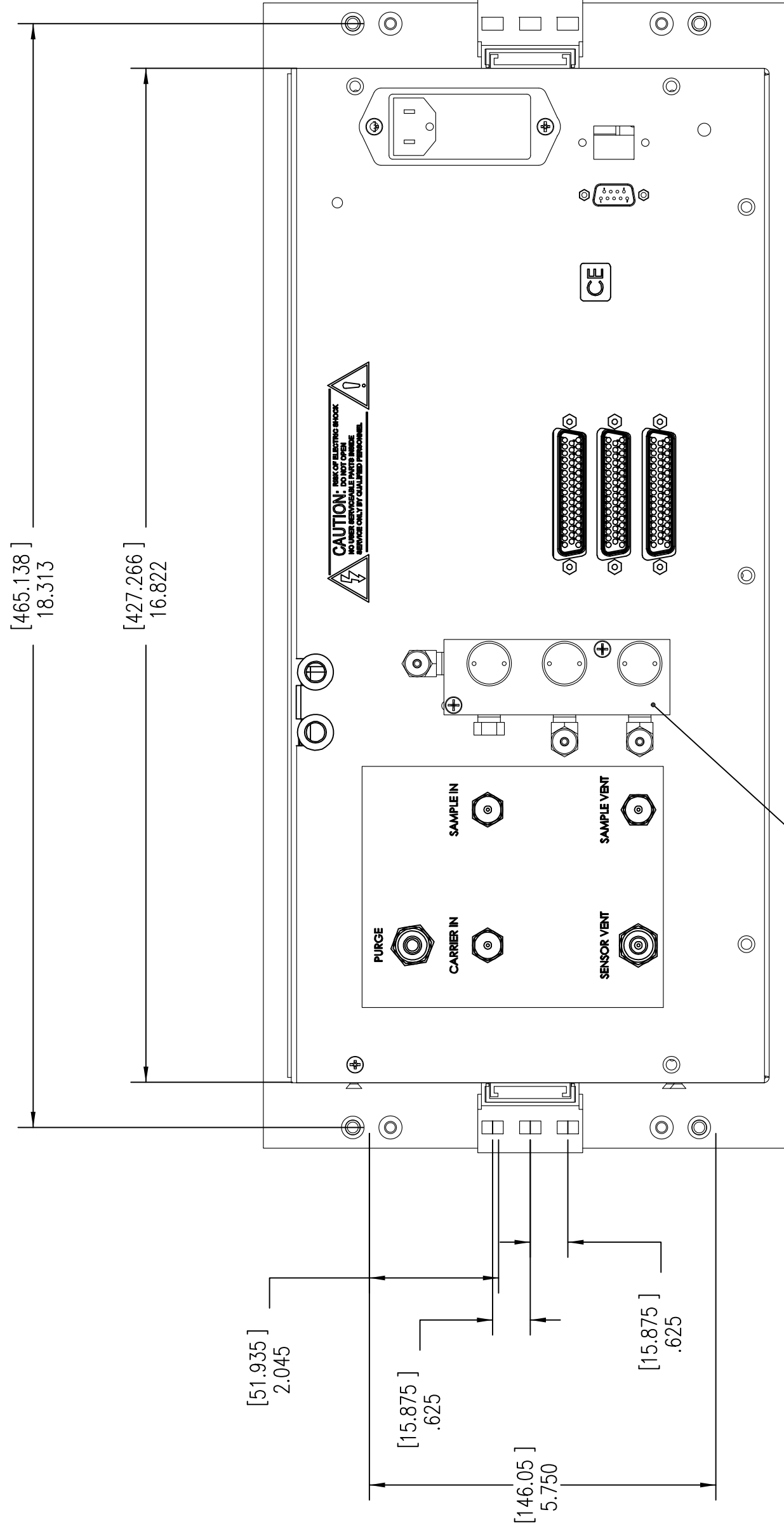

REAR VIEW

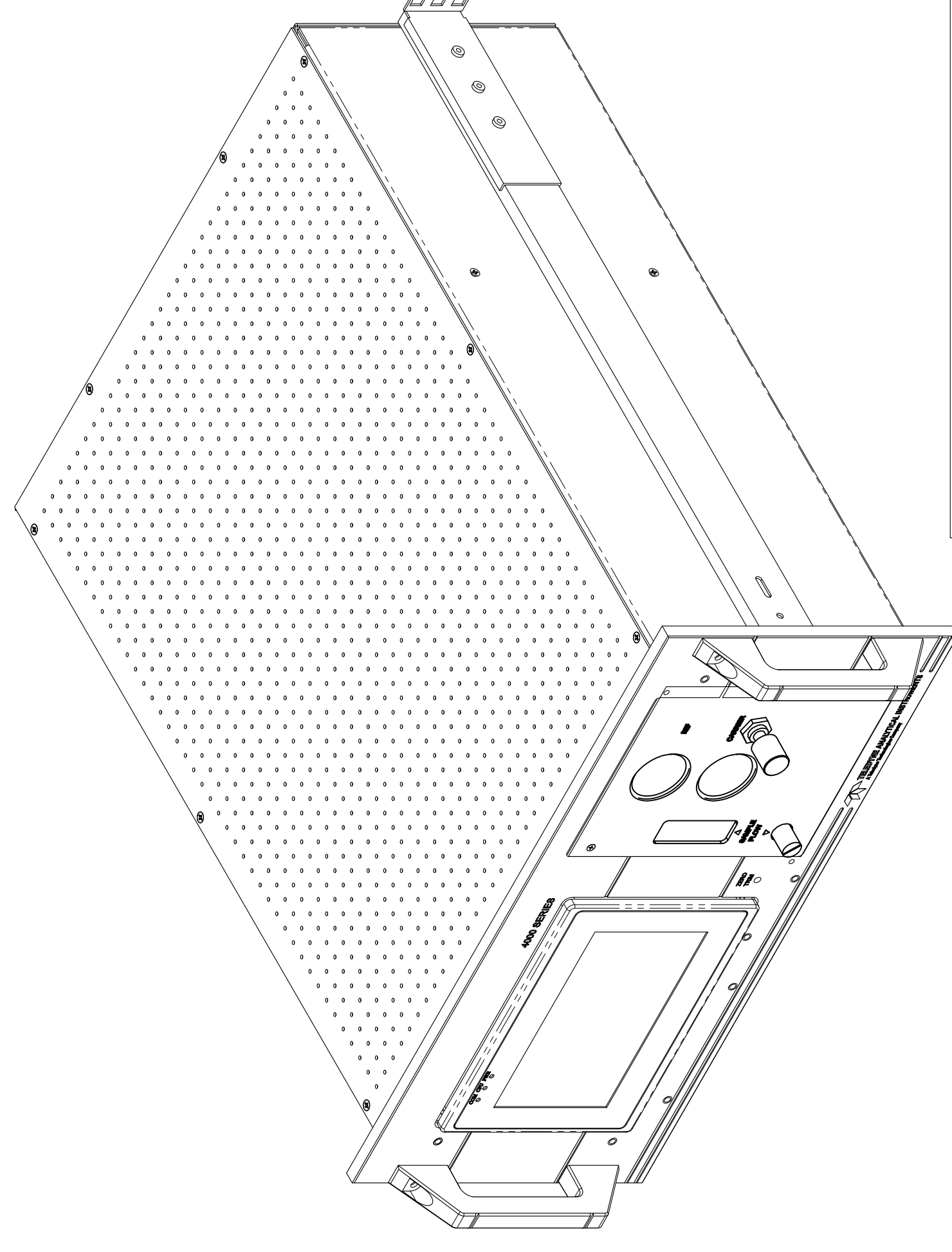

REVISIONS			
REV.	DESCRIPTION	DATE	APP.
0	INITIAL RELEASE	06/27/12	KN
			REV. BY
			--

TOLERANCE UNLESS OTHERWISE SPECIFIED:		SIGNATURES		DATE		TITLE		SCALE	
ANGULAR ±1/2	= ± 0.1	DFT: JORGE ASEVEDO	6/27/2012			OUTLINE DIAGRAM		1:2	
LINEAR ±.XX	= ± 0.02	CHK:				TCD GC PRO		SIM NONE	
LINEAR ±.XXX	= ± 0.010	APP: KIET NGO				MODEL 4040		SHEET 1 OF 1	
				ENG: KIET NGO		MATERIAL		REV	
				S.O. STANDARD		DWG NO. D89442		REV 0	
				REFERENCE		DWG ID D89442-0			

BILL OF MATERIALS
 THIS DRAWING IS THE PROPERTY OF TELEDYNE ANALYTICAL INSTRUMENTS AND CONTAINS CONFIDENTIAL INFORMATION. IT IS NOT TO BE COPIED, REPRODUCED OR USED WITHOUT WRITTEN PERMISSION.

Teledyne Analytical Instruments
 A Teledyne Technologies Company
 City of Industry, California, 91748, USA