

Use and Disclosure of Data
Information contained herein is classified as EAR99 under the
U.S. Export Administration Regulations.
Export, reexport or diversion contrary to U.S. law is prohibited.

OPERATING INSTRUCTIONS FOR

INSTA-TRANS

Trace and Percent Oxygen Transmitter



P/N M73994
02/25/15



DANGER



Toxic gases and or flammable liquids may be present in this monitoring system.
Personal protective equipment may be required when servicing this instrument.
Hazardous voltages exist on certain components internally which may persist
for a time even after the power is turned off and disconnected.
Only authorized personnel should conduct maintenance and/or servicing.
Before conducting any maintenance or servicing, consult with authorized
supervisor/manager.

EU DECLARATION OF CONFORMITY

This declaration of conformity is issued under the sole responsibility of the manufacturer

APPLICATION OF COUNCIL : 2014/34/EU
ATEX DIRECTIVE

STANDARDS TO WHICH : EN 60079-0:2012
CONFORMITY IS DECLARED : EN 60079-11:2012

MANUFACTURER'S NAME : Teledyne Analytical Instruments

MANUFACTURER'S ADDRESS : 16830 Chestnut Street
City of Industry, CA 91748
U.S.A.

TYPE OF EQUIPMENT : Oxygen Measuring Transmitter
Type Insta Trans

EQUIPMENT CLASS : Ex II 2 (1) G Ex ia IIC T4 Gb
(0°C ≤ Ta ≤ +50°C)

MODEL NUMBER : 3001 Insta Trans

I, the undersigned, hereby declare that the equipment specified above conforms to the referenced standards (s) per 2014/34/EU and have been type-approved by SGS Baseefa Limited, Staden Lane, Buxton, Derbyshire SK17 9RZ, UK. Baseefa notified body identification number: 1180. Mark: Ex II 2 (1) G. Code: Ex ia IIC T4 Gb (0°C ≤ Ta ≤ + 50°C). EC Type Certificate Number: BAS01ATEX2200X

SIGNATURE: 

FULL NAME: Roger Starlin

POSITION: QA Manager

Date: 7-27-18

PLACE: City of Industry, California

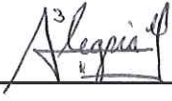
SIGNATURE: 

FULL NAME: Angel Alegria

POSITION: New Products Manager

Date: 7-27-18

PLACE: City of Industry, California

Copyright © 2015 Teledyne Analytical Instruments

All Rights Reserved. No part of this manual may be reproduced, transmitted, transcribed, stored in a retrieval system, or translated into any other language or computer language in whole or in part, in any form or by any means, whether it be electronic, mechanical, magnetic, optical, manual, or otherwise, without the prior written consent of Teledyne Analytical Instruments, 16830 Chestnut Street, City of Industry, CA 91748.

Warranty

This equipment is sold subject to the mutual agreement that it is warranted by us free from defects of material and of construction, and that our liability shall be limited to replacing or repairing at our factory (without charge, except for transportation), or at customer plant at our option, any material or construction in which defects become apparent within one year from the date of shipment, except in cases where quotations or acknowledgements provide for a shorter period. Components manufactured by others bear the warranty of their manufacturer. This warranty does not cover defects caused by wear, accident, misuse, neglect or repairs other than those performed by Teledyne or an authorized service center. We assume no liability for direct or indirect damages of any kind and the purchaser by the acceptance of the equipment will assume all liability for any damage which may result from its use or misuse.

We reserve the right to employ any suitable material in the manufacture of our apparatus, and to make any alterations in the dimensions, shape or weight of any parts, in so far as such alterations do not adversely affect our warranty.

Important Notice

This instrument provides measurement readings to its user, and serves as a tool by which valuable data can be gathered. The information provided by the instrument may assist the user in eliminating potential hazards caused by his process; however, it is essential that all personnel involved in the use of the instrument or its interface, with the process being measured, be properly trained in the process itself, as well as all instrumentation related to it.

The safety of personnel is ultimately the responsibility of those who control process conditions. While this instrument may be able to provide early warning of imminent danger, it has no control over process conditions, and it can be misused. In particular, any alarm or control systems installed must be tested and understood, both as to how they operate and as to how they can be defeated. Any safeguards required such as locks, labels, or redundancy, must be provided by the user or specifically requested of Teledyne at the time the order is placed.

Therefore, the purchaser must be aware of the hazardous process conditions. The purchaser is responsible for the training of personnel, for providing hazard warning methods and instrumentation per the appropriate standards, and for ensuring that hazard warning devices and instrumentation are maintained and operated properly.

Teledyne Analytical Instruments, the manufacturer of this instrument, cannot accept responsibility for conditions beyond its knowledge and control. No statement expressed or implied by this document or any information disseminated by the manufacturer or its agents, is to be construed as a warranty of adequate safety control under the user's process conditions.

Specific Model Information

The instrument for which this manual was supplied may incorporate one or more options not supplied in the standard instrument. Commonly available options are listed below, with check boxes. Any that are incorporated in the instrument for which this manual is supplied are indicated by a check mark in the box.

Instrument Serial Number: _____

Cell Class:

- A5
- B1
- B2C
- A2C
- L2C
- Insta-Trace

Insta-Trans Transmitter Model:

Stainless Steel Version

- Standard C73994-A
- Right Angle C73994-B
- Standard with Insta-Trace Option C73994-C
- Right Angle with Insta-Trace Option C73994-D

POMALUX CN-F Version

- Standard C73994-E
- Right Angle C73094-F
- Standard with Insta-Trace Option C73994-G
- Right Angle with Insta-Trace Option C73994-H

A5 Sensor Version

- Standard C73994-L
- Right Angle C73994-M

Table of Contents

Cell Class:	iii
List of Figures	vi
Introduction	1
1.1 Overview	1
1.2 Typical Applications	1
1.3 Main Features of the Transmitter	1
1.4 Operator Interface	2
1.5 Special Conditions for Safe Use	4
Operational Theory	5
2.1 Introduction	5
2.2 Micro-fuel Cell Sensor	5
2.2.1 Principles of Operation	5
2.2.2 Anatomy of a Micro-fuel Cell	6
2.2.3 Electrochemical Reactions	7
2.2.4 The Effect of Pressure	8
2.2.5 Calibration Characteristics	8
2.3 Sample System	10
2.4 Electronics and Signal Processing	11
Installation	13
3.1 Unpacking the Transmitter	13
3.2 Mounting the Transmitter	13
3.3 Gas Connections	13
3.4 Electrical Connections	15
3.5 Installing the Micro-fuel Cell	16
3.6 Testing the System	16
Operation	19



Insta-Trans

4.1 Introduction	19
4.2 The <i>Range</i> and <i>Calibration</i> Functions	19
4.3 Calibration	20
Maintenance.....	23
5.1 Routine Maintenance	23
5.2 Cell Replacement	23
5.2.1 Storing and Handling Replacement Cells	23
5.2.2 When to Replace a Cell	24
5.2.3 Removing the Micro-fuel Cell	24
5.2.4 Cell Warranty	25
5.3 Insta-Trace Sensor	26
Appendix	29
Specifications	29
Recommended Spare Parts List	30
Drawings	31

List of Figures

Figure 1-1: Range Selection.....	3
Figure 2-1: Micro-fuel Cell.....	6
Figure 2-2: Cross Section of a Micro-fuel Cell (not to scale)	7
Figure 2-3: Characteristic Input/Output Curve for a Micro-fuel Cell.....	9
Figure 2-4: Gas and Other Connections to the Transmitter	10
Figure 2-5: Electronics Block Diagram	12
Figure 3-1: Insta-Trans Connections and Mounting Dimensions...	14
Figure 4-1: Insta-Trace Operation	21
Figure 5-1: Cell Removal	26
Figure 5-2: Cell Removal Insta-Trace	28

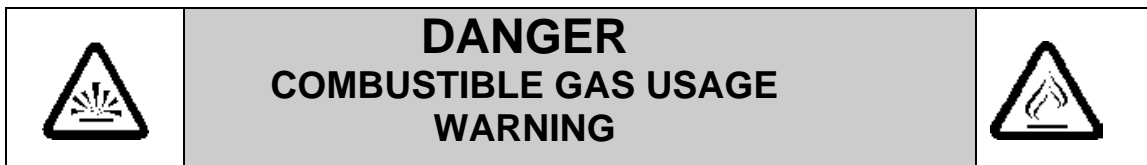

Warning! This instrument is not designed for use with oxygen enriched gases.

This instrument is designed for usage in a hazardous area. It is the customer's responsibility to ensure safety especially when combustible gases are being analyzed since the potential of gas leaks always exist.

The customer should ensure that the principles of operating of this equipment is well understood by the user. Misuse of this product in any manner, tampering with its components, or unauthorized substitution of any component may adversely affect the safety of this instrument.

Since the use of this instrument is beyond the control of Teledyne, no responsibility by Teledyne, its affiliates, and agents for damage or injury from misuse or neglect of this equipment is implied or assumed.

Introduction

1.1 Overview

The Teledyne Analytical Instruments Insta-Trans Trace Oxygen Transmitter is a versatile instrument for detecting oxygen at the parts-per-million (ppm) level in a variety of gases. This manual covers the Insta-Trans Trace Oxygen Transmitter. These units are NEMA-4 rated and may be used in hazardous environments.

The instrument is available in two standard versions: one rated for hazardous area use by Factory Mutual (FM), and another rated for hazardous area use by BASEEFA to ATEX Standards.

1.2 Typical Applications

A few typical applications of the Insta-Trans are:

- Monitoring inert gas blanketing
- Air separation and liquefaction
- Chemical reaction monitoring
- Semiconductor manufacturing
- Petrochemical process control
- Quality assurance
- Gas analysis certification.

1.3 Main Features of the Transmitter

The Insta-Trans Trace Oxygen Transmitter is sophisticated yet simple to use. The main features of the analyzer include:

- 3½ digit LCD display with range and calibration annunciators.
- Six ranges: 0-10 ppm through 0-25%.

- Stainless steel or [POMALUX CN-F](#) cell block.
- Simple push-button calibration and range selection.
- Advanced Micro-fuel Cell, redesigned for trace analysis, has a one year warranty and an expected lifetime of two years.
- Air-calibration range for convenient spanning at 20.9 %.
- True 2-wire 4-20 mA powered loop interface.

1.4 Operator Interface

The standard Insta-Trans is housed in a rugged NEMA-4 rated metal case with all switches and the display accessible from the outside. Figure 1-1 illustrates the Insta-Trans display and switches while Table 1-1 shows the decimal point (DP) location for the various ranges.

Function Keys: Six touch-sensitive membrane switches are used to set the range and calibrate the transmitter.

- **RANGE** Selects the Range mode and sets the desired range.
- **COARSE** Selects the Coarse calibration mode.
- **FINE** Selects the Fine calibration mode.
- **RUN** Selects the Run mode.
- **▲** Used to adjust the calibration upward in Coarse and Fine mode.
- **▼** Used to adjust the calibration downward in Coarse and Fine mode.
- **DISPLAY** 3 1/2 digit O₂ concentration LCD display with annunciators

Table 1-1: Decimal Location for Selected Range

Range	Decimal Location
0-10 PPM	Decimal Point (DP) 2 X.XX
0-100 PPM	Decimal Point (DP) 1 XX.X
0-1000 PPM	No Decimal Point XXX
0-1%	Decimal Point (DP) 3 .XXX
0-10%	Decimal Point (DP) 2 X.XX
0-25%	Decimal Point (DP) 1 XX.X

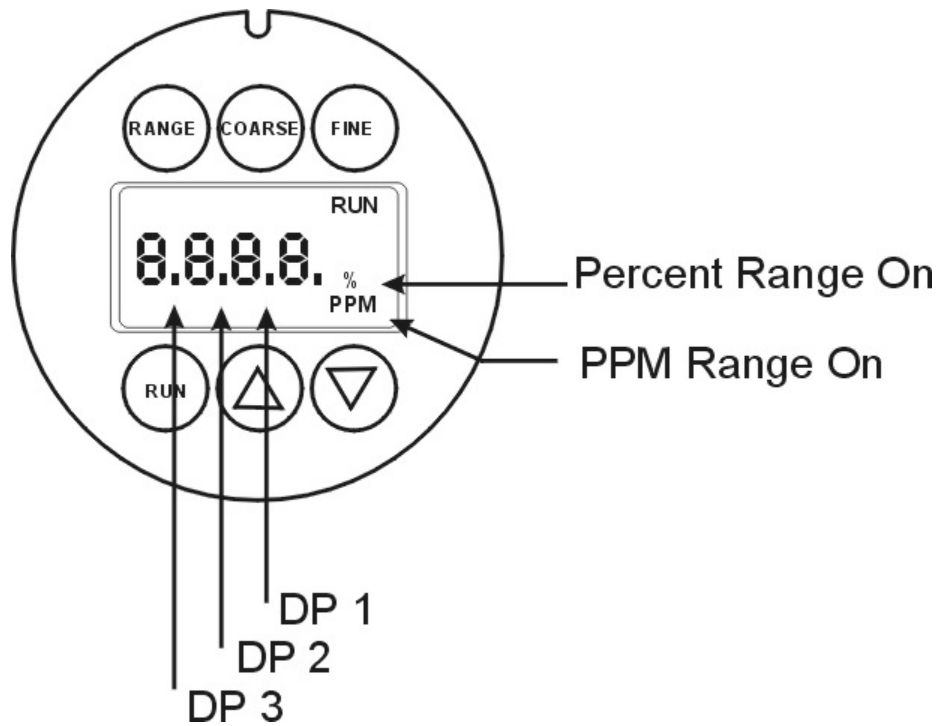

Figure 1-1: Range Selection

1.5 Special Conditions for Safe Use

1. The apparatus enclosure must be earthed via its earthing strap to prevent electrostatic hazards.
2. The apparatus must not be used to measure oxygen enriched gases i.e. gases with greater than 21% oxygen content.
3. Pins 1 and 3 of the connector are connected to the apparatus enclosure, this must be taken into account in any apparatus installation.

Operational Theory

2.1 Introduction

The transmitter is composed of three subsystems:

1. Micro-fuel Cell Sensor
2. Sample System
3. Electronic Signal Processing, Display and Control

The sample system is designed to accept the sample gas and transport it through the transmitter without contaminating or altering the sample prior to analysis. The Micro-fuel Cell is an electrochemical galvanic device that translates the amount of oxygen present in the sample into an electrical current. The electronic signal processing, display and control circuits simplify operation of the transmitter and accurately displays the sampled data.

2.2 Micro-fuel Cell Sensor

2.2.1 Principles of Operation

The oxygen sensor used in the Insta-Trans series is a Micro-fuel Cell designed and manufactured by Analytical Instruments. It is a sealed plastic disposable electrochemical transducer.

The active components of the Micro-fuel Cell are a cathode, an anode, and the 15% aqueous KOH electrolyte in which they are immersed. The cell converts the energy from a chemical reaction into an electrical current in an external electrical circuit. Its action is similar to that of a battery.

There is, however, an important difference in the operation of a battery as compared to the Micro-fuel Cell: In the battery, all reactants are stored within the cell, whereas in the Micro-fuel Cell, one of the reactants (oxygen) comes from outside the device as a constituent of the sample gas being analyzed. The Micro-fuel Cell is therefore a hybrid

between a battery and a true fuel cell. (All of the reactants are stored externally in a true fuel cell.)

2.2.2 Anatomy of a Micro-fuel Cell

The Micro-fuel Cell is a cylinder only 1¼ inches in diameter and 1¼ inches thick. It is made of an extremely inert plastic, which can be placed confidently in practically any environment or sample stream. It is effectively sealed, although one end is permeable to oxygen in the sample gas. The other end of the cell is a contact plate consisting of two concentric foil rings. The rings mate with spring-loaded contacts in the sensor block assembly and provide the electrical connection to the rest of the analyzer. Figure 2-1 illustrates the external features.

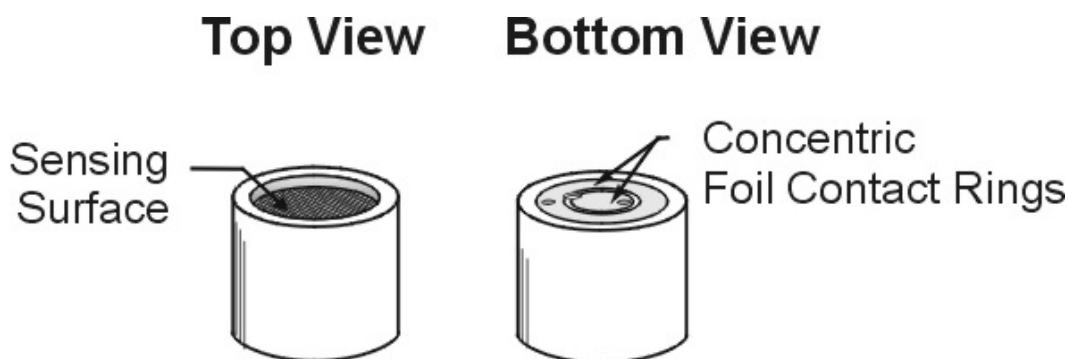

Figure 2-1: Micro-fuel Cell

Refer to Figure 2-2, *Cross Section of a Micro-fuel Cell*, which illustrates the following internal description.

At the top end of the cell is a diffusion membrane of Teflon, whose thickness is very accurately controlled. Beneath the diffusion membrane lies the oxygen sensing element—the cathode—with a surface area almost 4 cm². The cathode has many perforations to ensure sufficient wetting of the upper surface with electrolyte, and it is plated with an inert metal.

The anode structure is below the cathode. It is made of lead and has a proprietary design which is meant to maximize the amount of metal available for chemical reaction.

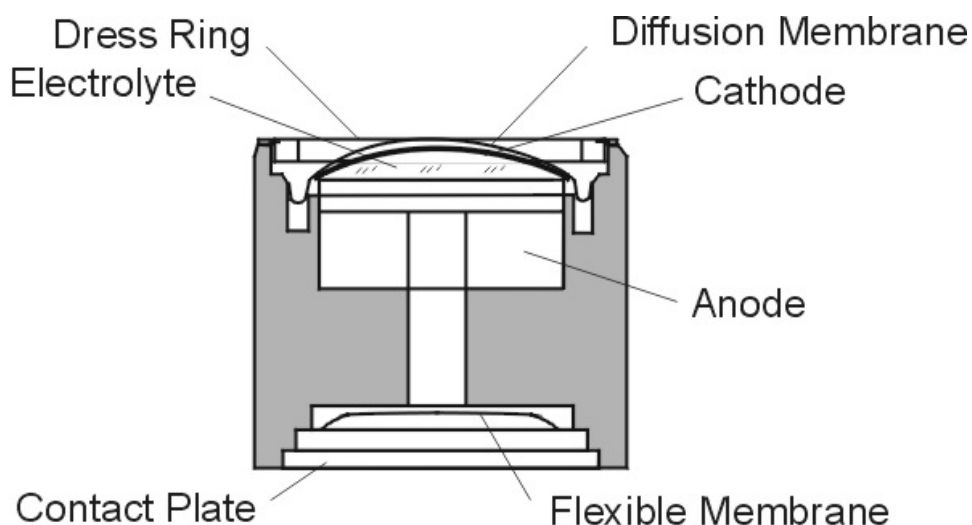

Figure 2-2: Cross Section of a Micro-fuel Cell (not to scale)

At the rear of the cell, just below the anode structure, is a flexible membrane designed to accommodate the internal volume changes that occur throughout the life of the cell. This flexibility assures that the sensing membrane remains in its proper position, keeping the electrical output constant.

The entire space between the diffusion membrane, above the cathode, and the flexible rear membrane, beneath the anode, is filled with electrolyte. Cathode and anode are submerged in this common pool. They each have a conductor connecting them to one of the external contact rings on the contact plate, which is on the bottom of the cell.

2.2.3 Electrochemical Reactions

The sample gas diffuses through the Teflon membrane. Any oxygen in the sample gas is reduced on the surface of the cathode by the following HALF REACTION:



(Four electrons combine with one oxygen molecule—in the presence of water from the electrolyte—to produce four hydroxyl ions.)

When the oxygen is reduced at the cathode, lead is simultaneously oxidized at the anode by the following HALF REACTION:

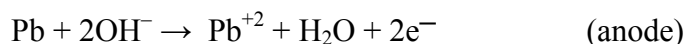

(Two electrons are transferred for each atom of lead that is oxidized. Therefore it takes two of the above anode reactions to balance one cathode reaction and transfer four electrons.)

The electrons released at the surface of the anode flow to the cathode surface when an external electrical path is provided. The current is proportional to the amount of oxygen reaching the cathode. It is measured and used to determine the oxygen concentration in the gas mixture.

The overall reaction for the fuel cell is the SUM of the half reactions above, or:

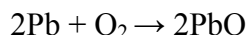

(These reactions will hold as long as no gaseous components capable of oxidizing lead—such as iodine, bromine, chlorine and fluorine—are present in the sample.)

The output of the fuel cell is limited by (1) the amount of oxygen in the cell at the time and (2) the amount of stored anode material.

In the absence of oxygen, no current is generated.

2.2.4 The Effect of Pressure

In order to state the amount of oxygen present in the sample in parts-per-million or a percentage of the gas mixture, it is necessary that the sample diffuse into the cell under constant pressure.

If the total pressure increases, the rate that oxygen reaches the cathode through the diffusing membrane will also increase. The electron transfer, and therefore the external current, will increase, even though the oxygen concentration of the sample has not changed. It is therefore important that the sample pressure at the fuel cell (usually vent pressure) remain relatively constant between calibrations.

2.2.5 Calibration Characteristics

Given that the total pressure of the sample gas on the surface of the Micro-fuel Cell input is constant, a convenient characteristic of the cell is that the current produced in an external circuit is directly proportional to the rate at which oxygen molecules reach the cathode, and this rate is directly proportional to the concentration of oxygen in the gaseous

mixture. In other words it has a linear characteristic curve, as shown in Figure 2-3. Measuring circuits do not have to compensate for nonlinearities.

In addition, since there is zero output in the absence of oxygen, the characteristic curve has close to an absolute zero (within ± 0.5 ppm oxygen).

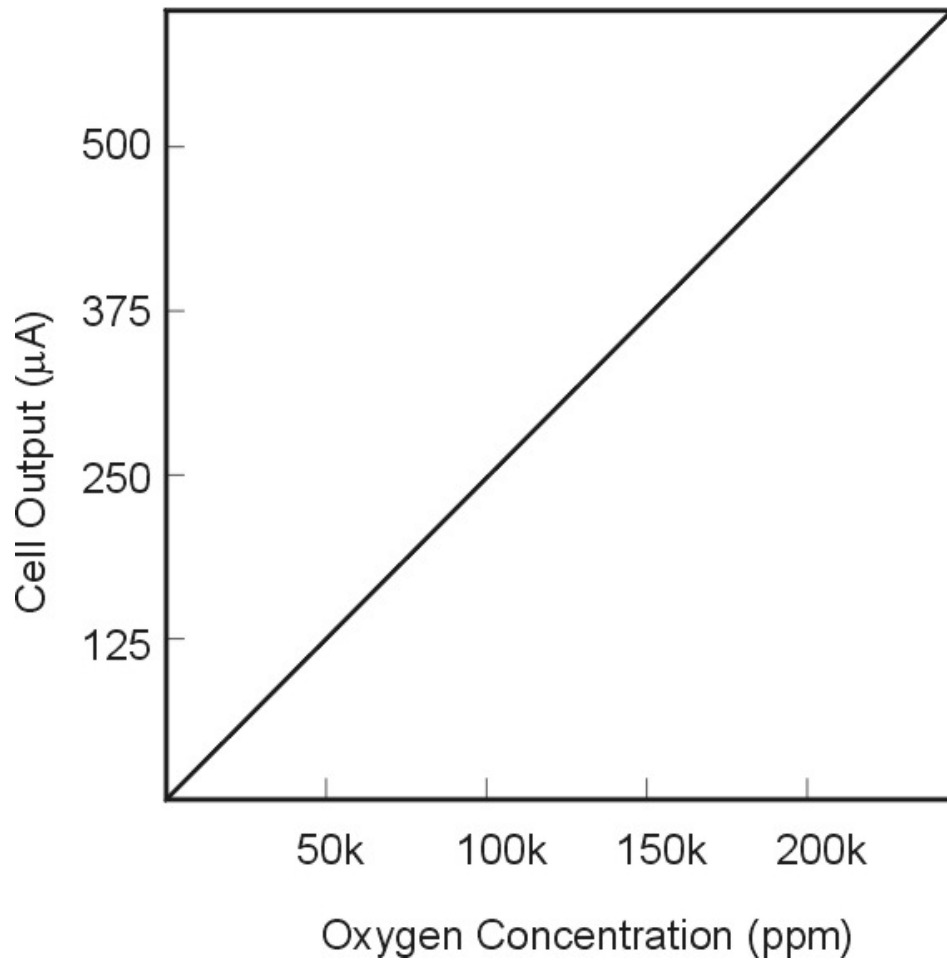

Figure 2-3: Characteristic Input/Output Curve for a Micro-fuel Cell

2.3 Sample System

The sample system delivers gases to the Micro-fuel Cell sensor from the transmitter gas inlet. Depending on the mode of operation either sample or calibration gas is delivered.

The Insta-Trans sample system is designed and fabricated to ensure that the oxygen concentration of the gas is not altered as it travels through the sample system. The sample encounters almost no dead space. This minimizes residual gas pockets that can interfere with trace analysis.

The sample system for the standard instrument incorporates 1/8 inch tube fittings for sample inlet and outlet connections. For metric system installations, 6 mm adapters can be supplied with each instrument to be used if needed (consult factory). The sample gas flows through the transmitter as shown in Figure 2-4.

The wetted parts of this analyzer are produced from stainless steel, nylon, gold, and viton. Prior to introducing a sample gas, care should be taken to insure that the sample gas is compatible with these materials.

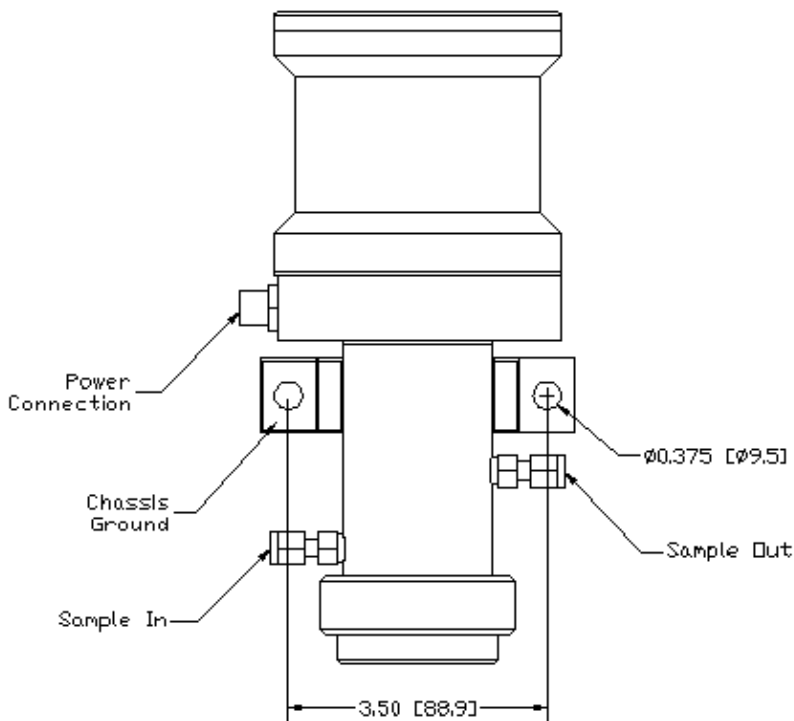

Figure 2-4: Gas and Other Connections to the Transmitter

2.4 Electronics and Signal Processing

The Insta-Trans Trace Oxygen transmitter uses standard electronic circuitry. Power is supplied via the 4-20 mA current loop.

The processing electronics are located inside the transmitter case. Three boards are accessible after removing the top housing. Figure 2-5 is a block diagram of the transmitter electronics.

In the presence of oxygen the cell generates a current. A current to voltage amplifier converts this current to a voltage, which is amplified in the second stage amplifier.

The second stage amplifier also supplies temperature compensation for the oxygen sensor output. This amplifier circuit incorporates a thermistor, which is physically located in the cell block. The thermistor is a temperature dependent resistance that changes the gain of the amplifier in proportion to the temperature changes in the block. This change is inversely proportional to the change in the cell output due to the same temperature changes. The result is a signal that is temperature independent. The output from the second stage amplifier is sent to the 3 1/2 digit DVM/Display and voltage to current converter/driver.

The 3-1/2 digit DVM/Display provides a visual indication of the oxygen concentration in ppm or % depending on the range selected. Range selection and calibration information are entered from the key pad and processed through the key pad control, the input range selection and the calibration control circuits. All power needed to run the Insta-Trans transmitter is derived from the signal current loop. Calibration settings are maintained indefinitely when the signal current loop is disconnected. Range settings are maintained for a minimum of 72 hours through the use of a 0.1 Farad storage capacitor when the signal current loop is disconnected. The transmitter always defaults to Run mode when the signal current loop is connected.

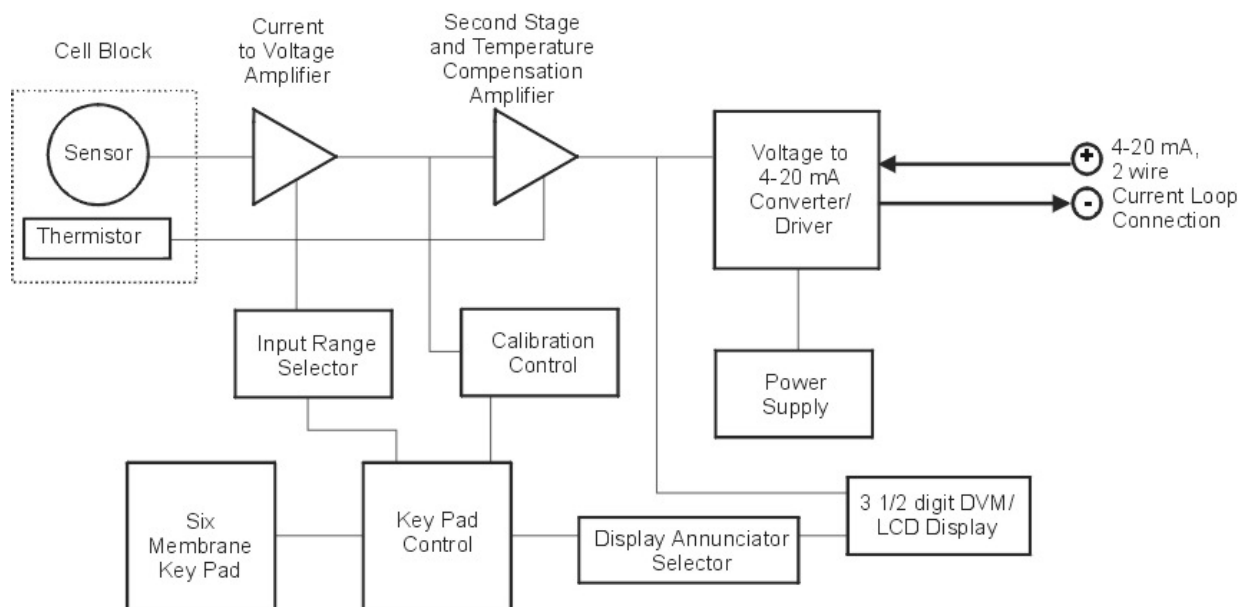

Figure 2-5: Electronics Block Diagram

Installation

Installation of the Insta-Trans Transmitter includes:

- Unpacking
- Mounting
- Gas connections
- Electrical connections
- Installing the Micro-fuel Cell
- Testing the system.

3.1 Unpacking the Transmitter

The transmitter is shipped with all the materials you need to install and prepare the system for operation. Carefully unpack the transmitter and inspect it for damage. Immediately report any damage to the shipping agent.

3.2 Mounting the Transmitter

The Insta-Trans is intended for indoor or outdoor use, however the equipment is not intended to be used in areas exposed to dust.

The Insta-Trans transmitter is provided with a wall mount bracket. Refer to Figure 3-1 for mounting information and dimensions. The display and operator control switches are located on the top of the transmitter. This should be taken into consideration when determining mounting location. Mount the transmitter with the sensor housing vertical and the cell holder on the bottom.

3.3 Gas Connections

The unit is manufactured with 1/8 inch tube fittings (consult factory for other sizes). For a safe connection:

1. Insert the tube into the tube fitting, and finger-tighten the nut until the tubing in the fitting cannot be rotated freely by hand. (This may require an additional 1/8 turn beyond finger-tight.)
2. Hold the fitting body steady with a backup wrench, and with another wrench rotate the nut another 1-1/4 turns.

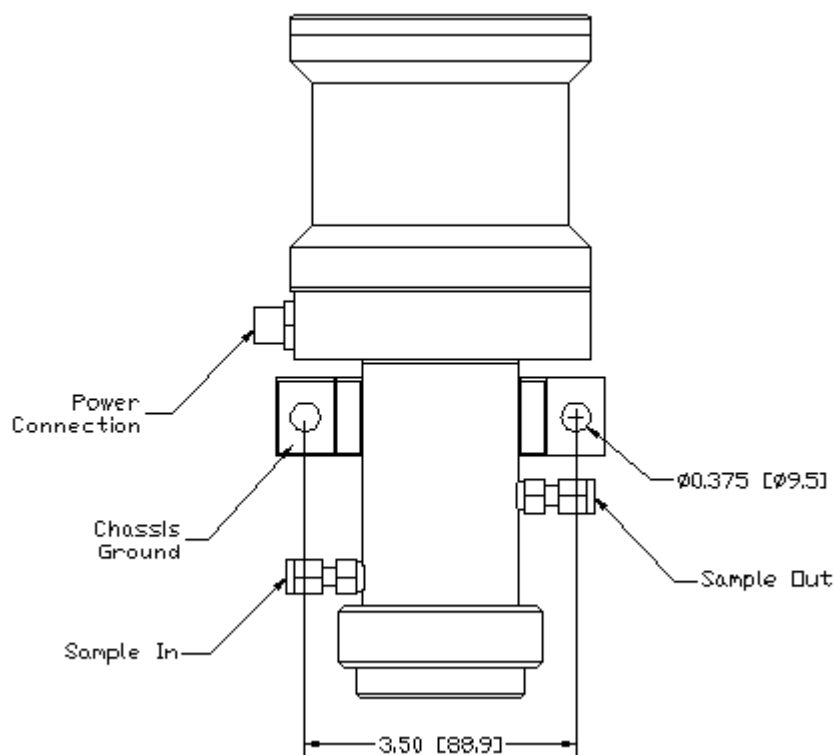

Figure 3-1: Insta-Trans Connections and Mounting Dimensions

SAMPLE IN: Gas connections are made at the SAMPLE IN connector.

The gas pressure in should be reasonably regulated. A flow control device must be installed before the sample in port if the sample pressure is above 0.5 psig.

If greater flow is required for improved response time (over 20 SCFH), install a bypass in the sampling system upstream of the analyzer input.

EXHAUST OUT: Exhaust connections must be consistent with the

hazard level of the constituent gases. Check local, state, and federal laws, and ensure that the exhaust stream vents to an appropriately controlled area if required. The exhaust should be vented to atmospheric pressure, through a short length of tubing (3'). The vent tubing should not be less than 1/8".

3.4 Electrical Connections

The Insta-Trans analyzer requires two electrical connections. A chassis ground connection should be made to the left side of the mounting bracket. This is required to reduce the sensitivity to radio frequency interference (RFI). An adequate ground connection is can be established by mounting the analyzer to a metal structure, or attaching a ground cable with lug (3/8") to the left side mounting bolt.

The signal and power are supplied by a single 4 pin electrical connector on the left side of the analyzer. The Insta-Trans is supplied with a twenty-four inch cable which mates with the power/signal connector. Other cable lengths are available or the mating connector can be supplied for customer use, see spare parts list in the rear of the manual.

Wiring: The Insta-Trans is equipped with a four pin removable connector (screw connections). The connector allows the user to easily install or remove the analyzer. Ref. B71625

The connector should be wired per B71625, interconnection is per A71629 (D73736 for BASEEFA approved installations).

The cable or wire required will depend on the specific application. A shielded cable should be used when ever possible to improve resistance to radio interference. The wire gage should be selected based on the length of the cable. A minimum wire gage of 22 is recommended. The maximum wire gage is limited by the size of the connector. A larger gage wire is required for longer cable runs due to the voltage drop associated with the cable resistance. A 1000 foot 22 gage cable will have a voltage drop of 0.59 VDC (29.5 ohms x 20ma) at full scale. A 1000 foot 18 gage cable will have a voltage drop of 0.26 VDC (12.96 ohms x 20ma). The above voltage will be added to the minimum voltage required for the transmitter.

If the unit purchased is the version approved by BASEEFA, the interconnections should follow the instructions on D73736.

A typical installation will include a load resistor. The value of the resistor is dependent on the full-scale output voltage signal required. For a full-scale output of 5 VDC the resistor value is 250 ohms (5V/20mA). For a full-scale output of 1 VDC the resistor value will be 50 ohms (1V/20mA). The output voltage is also added to the minimum voltage for the transmitter.

The operating voltage range of the transmitter is 9.3 – 30 VDC. The wiring and load resistor voltage drops must be included in determining the minimum voltage requirement. The minimum operating voltage required with a 500 foot 20 gage cable and a 250 ohm load resistor is 14.4 VDC ($9.3V + (5.1 + 250) \text{ ohms} \times 20\text{ma}$).

For Intrinsically Safe (IS) installation, special considerations are required. The Insta-Trans analyzer has been designed to be Intrinsically Safe when used with a properly selected and installed safety barrier. This design utilizes redundant safety features to prevent the Insta-Trans from becoming an ignition source in the event of a circuit failure. The user should consult with the proper certifying agency prior to installation. Safety barriers reduce the possibility of fires or explosion in hazardous locations by limiting the energy available for ignition. Reference the BASEEFA Interconnection Diagram D-73736.

3.5 Installing the Micro-fuel Cell

The Micro-fuel Cell is not installed in the cell block when the instrument is shipped. It must be installed before the analyzer is placed in service.

Once it is expended, or if the cell (trace O₂) is exposed to air for too long, the Micro-fuel Cell will need to be replaced (B1 cells are designed for use in % levels of O₂ such as air). The cell could also require replacement if the instrument has been idle for too long.

When the Micro-fuel Cell needs to be installed or replaced, follow the procedures in Chapter 5, *Maintenance*, for removing and installing cells.

3.6 Testing the System

Before connecting the signal wires to the transmitter:

- Check the integrity and accuracy of the gas connections. Make sure there are no leaks.

- Verify that the restriction device has been properly installed (see section 3.3).
- Check that inlet sample pressure is within the accepted range (see section 3.3).

Connect the signal wires and energize the signal line, and test the transmitter by performing the following:

1. Observe that the LCD display illuminates and that the transmitter starts up in Run mode. If the transmitter is being energized for the first time or has been disconnected from the power for a long period of time, wait about 60 seconds for the 0.1 Farad storage capacitor to charge up before attempting any tests.
2. If the right three digits of the LCD display are blank, the transmitter is in an over range condition. Push the **RANGE** button once to enter the Range Select mode. Observe that the **RNG** annunciator illuminates. Push the **RANGE** button until the transmitter displays an “in range” condition.

Note: The transmitter can display a 99.9% over range condition, so select a range where the left-most digit is blank.

3. Push the **COARSE** button. Observe that the **CRS** annunciator illuminates on the display.
4. Push the **▲** and **▼** buttons. Observe that the gas concentration reading goes up and down in rather coarse increments as the buttons are pushed.
5. Push the **FINE** button. Observe that the **CRS** annunciator goes out and the **FIN** annunciator illuminates on the display.
6. Push the **▲** and **▼** buttons. Observe that the gas concentration reading goes up and down in fine increments as the buttons are pushed.
7. Push the **RUN** button. Observe that the **FIN** and **RNG** annunciators go out. The transmitter is now in Run mode.

Operation

4.1 Introduction

Once the transmitter has been installed, it must be configured to your application. To do this you must:

- Set the range.
- Calibrate the instrument.

4.2 The *Range* and *Calibration* Functions

The transmitter is calibrated by using span gas.

Although the instrument can be spanned using air, a span gas with a known oxygen concentration in the range of 70–90% of full scale of the range of interest is recommended. Since the oxygen concentration in air is 20.9% (209,000 ppm), the cell can take a long time to recover if the instrument is used for trace oxygen analysis immediately following calibration in air.

Connect the calibration gases to the transmitter according to the instructions given in Section 3.3, *Gas Connections*, observing all the prescribed precautions.

The gas supply should be off or set to a low flow before connecting it to the transmitter, and be sure not to obstruct the sample vent.

CAUTION: **IN THE EVENT OF LOSS OF FLOW THROUGH THE TRANSMITTER, IF THE VENT IS VENTED TO A LOCATION OF HIGH OXYGEN CONTENT, OXYGEN WILL BACK DIFFUSE THROUGH THE VENT LINE AND IN MOST CASES QUICKLY SATURATE THE CELL WITH OXYGEN WHICH CAN THEN REQUIRE A LONG PURGE DOWN TIME FOR THE SENSOR WHEN USED FOR LOW OXYGEN CONCENTRATION MEASUREMENTS. IN THE EVENT THAT FLOW IS INTERRUPTED INTO THE TRANSMITTER, IT IS**



SUGGESTED THAT THE USER DO ONE OF THE FOLLOWING:

1. Bag the sensor in nitrogen during this time
2. Install a shut off valve on the vent port of the transmitter or somewhere within the users sample system.

4.3 Calibration

Follow the following instructions to calibrate the Insta-Trans Trace Oxygen Transmitter. Refer to figure 4-1.

1. Select range to be calibrated and enable calibration gas flow.
2. Press **RUN** to turn off Run mode and wait until the display reading is stable before beginning the span adjustment.
3. Once the reading is stable press **COARSE** to select the Coarse mode.
4. Adjust the 'COARSE' range up or down using the ▲ and ▼ keys until the display reads the value that is closest to the calibration gas oxygen concentration level.
5. When set to a value close to the calibration gas concentration level press **FINE** to select the Fine mode.
6. Adjust the 'FINE' range up or down until the display reads the value of the calibration gas oxygen concentration level. If unable to reduce the Fine range lower, proceed to step 7. If unable to increase the Fine range higher, proceed to step 8. Else, proceed to step 9.
7. Set the transmitter into 'COARSE' mode and adjust the Coarse range **DOWN** exactly 4 increments. Then, go back to step 5.
8. Set the transmitter into 'COARSE' mode and adjust the Coarse range **UP** exactly 4 increments. Then, go back to step 5.
9. Press **RUN** to complete calibration.

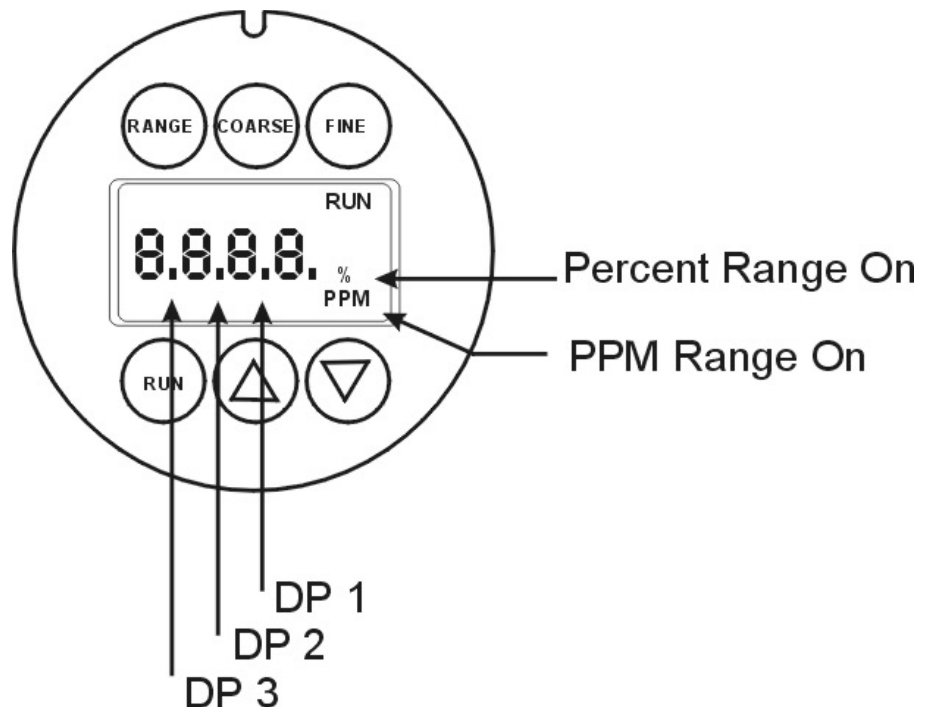

Figure 4-1: Insta-Trace Operation

Maintenance

5.1 Routine Maintenance

Aside from normal cleaning and checking for leaks at the gas connections, routine maintenance is limited to replacing Micro-fuel Cells and recalibration. For recalibration, see Section 4 *Calibration*.

This equipment is not to be repaired by the user and is to be replaced by an equivalent certified unit. Repairs should only be carried out by the manufacturer or approved repairer.

WARNING: SEE WARNINGS ON THE TITLE PAGE OF THIS MANUAL.



5.2 Cell Replacement

A Micro-fuel Cell is a sealed electrochemical transducer with no electrolyte to change or electrodes to clean. When the cell reaches the end of its useful life, it is replaced. The spent fuel cell should be discarded according to local regulations. This section describes fuel cell care as well as when and how to replace it.

5.2.1 Storing and Handling Replacement Cells

To have a replacement cell available when it is needed, TAI recommends that one spare cell be purchased 9-10 months after commissioning the Insta-Trans, or shortly before the end of the cell's one year warranty period.

CAUTION: DO NOT STOCKPILE CELLS. THE WARRANTY PERIOD STARTS ON THE DAY OF SHIPMENT.



The spare cell should be carefully stored in an area that is not subject to large variations in ambient temperature (75 °F nominal) or to rough handling.

WARNING:  THE SENSOR USED IN THE INSTA-TRANS TRACE OXYGEN TRANSMITTER USES ELECTROLYTES WHICH CONTAIN TOXIC SUBSTANCES, MAINLY LEAD AND POTASSIUM HYDROXIDE, THAT CAN BE HARMFUL IF TOUCHED, SWALLOWED, OR INHALED. AVOID CONTACT WITH ANY FLUID OR POWDER IN OR AROUND THE UNIT. WHAT MAY APPEAR TO BE PLAIN WATER COULD CONTAIN ONE OF THESE TOXIC SUBSTANCES. IN CASE OF EYE CONTACT, IMMEDIATELY FLUSH EYES WITH WATER FOR AT LEAST 15 MINUTES. CALL PHYSICIAN. (SEE APPENDIX, MATERIAL SAFETY DATA SHEET.)

CAUTION:  DO NOT DISTURB THE INTEGRITY OF THE CELL PACKAGE UNTIL THE CELL IS TO ACTUALLY BE USED. IF THE CELL PACKAGE IS PUNCTURED AND AIR IS PERMITTED TO ENTER, THE CELL WILL REQUIRE AN EXCESSIVELY LONG TIME TO REACH ZERO AFTER INSTALLATION (1-2 WEEKS!).

5.2.2 When to Replace a Cell

The characteristics of the Micro-fuel Cell show an almost constant output throughout its useful life and then falls off sharply towards zero at the end. Cell failure in the Insta-Trans is usually characterized by the inability to span or excessive offset when used on low ppm ranges. Before replacing the cell:

1. Check your span gas to make sure it is within specifications.
2. Check for leaks downstream from the cell, where oxygen may be leaking into the system.

If there are no leaks and the span gas is OK, replace the cell.

5.2.3 Removing the Micro-fuel Cell

Remove the Cell Holder by holding the bottom in place and unscrewing the Collar until the Cell Holder falls out with the Cell. Remove the new cell from its package, and carefully remove the shorting clip. Place the cell on the cell holder with the screen side facing down and tighten the cell holder onto the instrument. See Figure 5-1.

5.2.4 Cell Warranty

The B2C cell is the standard trace sensor for the Insta-Trans. It is suitable for use in applications where the O₂ level is being measured on a ppm range. The warranty period of the Insta-Trace is six months from the date of shipment. This sensor has a life expectancy of eight months when used in trace measurement applications.

The B1C cell is the standard percent sensor for use with Insta-Trans. It is suitable for use when the analyzer will be used on a percent range. The B1C has a warranty period of six months from the date of shipment and a life expectancy of eight months in air.

The A2C cell is recommended for use in trace applications where the CO₂ concentration will be 0.1% or greater. The warranty period of the A2C is six months from the date of shipment. This sensor has a life expectancy of eight months when used in trace measurement applications.

The optional Class L2C Micro-fuel Cell can be used in the Insta-Trans. This cell is a long life cell for use in trace (ppm) applications and is warranted for 1 year from the date of shipment. Note any Addenda attached to the front of this manual for special information applying to your instrument.

With regard to spare cells, warranty period begins on the date of shipment. The customer should purchase only one spare cell (per section 5.2.1). Do not attempt to stockpile spare cells.

The B1, B2C, Insta-Trace, and L2C cells **are not designed for applications where CO₂ is a major component in the sample**, however intermittent concentrations of 1,000 ppm or less will not adversely effect the cell performance. Consult TAI for available options for either intermittent or continuous CO₂ exposure.

The A2C and A2C type Insta-Trans cell is recommended for trace applications when the sample gas contains significant levels of CO₂. The A2C cell is suitable for CO₂ concentration of 0 to 100%.

If a cell was working satisfactorily, but ceases to function before the warranty period expires, the customer will receive credit toward the purchase of a new cell.

If you have a warranty claim, you must return the cell in question to the factory for evaluation. If it is determined that failure is due to faulty workmanship or material, the cell will be replaced at no cost to you.

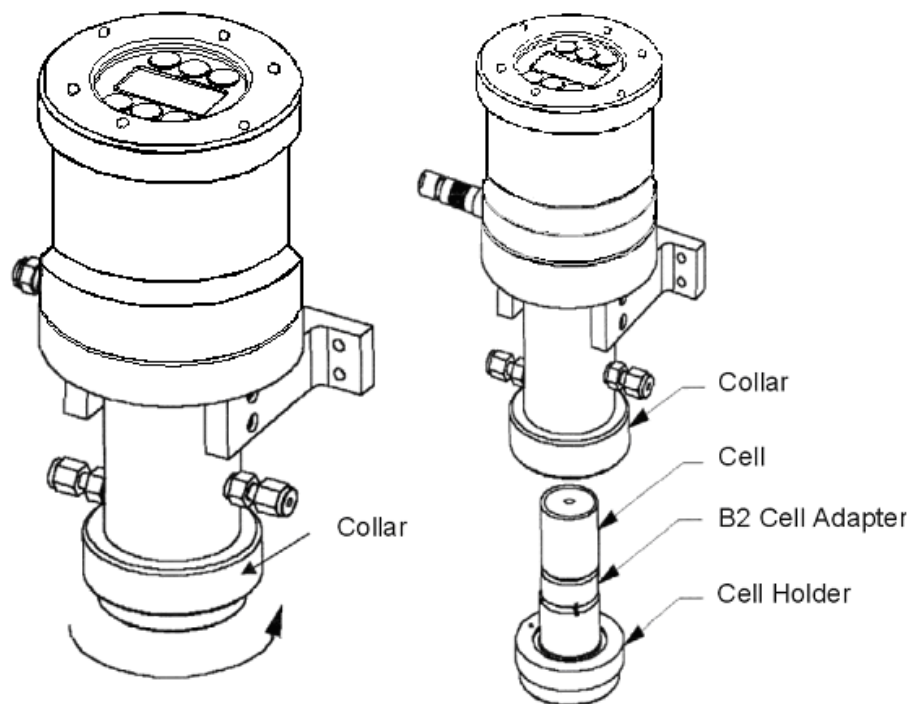

Figure 5-1: Cell Removal

5.3 Insta-Trace Sensor

Teledyne's Insta-Trace Sensor (patent pending) provides rapid sensor installation recovery time. The Insta-Trace system allows a new sensor to be installed and working at low ppm (parts per million) in a matter of minutes. The insta-Trace option includes the Insta-Trace Sensor and a special Insta-Trace cell holder (the B2 cell adapter is not used).

Any Insta-Trans can be converted to an Unsta-Trace by substituting the sensor and cell holder (see *Spare Parts Listing* in the Appendix).

The Insta-Trace system works by shielding the sensitive membrane from air during the installation process. These special cells have an outer membrane which seals the sensing membrane in a bath of N₂ until the membrane is punctured during the installation. External gas can reach the sensing membrane only after the external membrane is pierced. This process prevents air from contaminating the sensor during installation thus allowing rapid recovery to low ppm levels. For best results, the proper installation must be followed.

To install the Insta-Trace:

- The Insta-Trans transmitter must be purged with sample gas at a flow rate of approximately 0.2 SCFH during installation.
- Remove the Insta-Trace cell holder by unscrewing the collar (see Figure 5-2).
- Remove the B2 cell adapter if installed. Ref. Figure 5-1.
- Remove the Insta-Trace sensor from the double bags.
- Remove the shorting plug from the rear of the sensor.
- Install the sensor in the transmitter with the contact surface (two concentric gold circles) facing up, and the membrane facing down toward the cell holder.
- Orient the cell holder to align the registration pin with the hole in the cell holder.
- Push the cell holder firmly in place while rotating the collar (see Figure 5-2). The collar should be tightened finger-tight only.

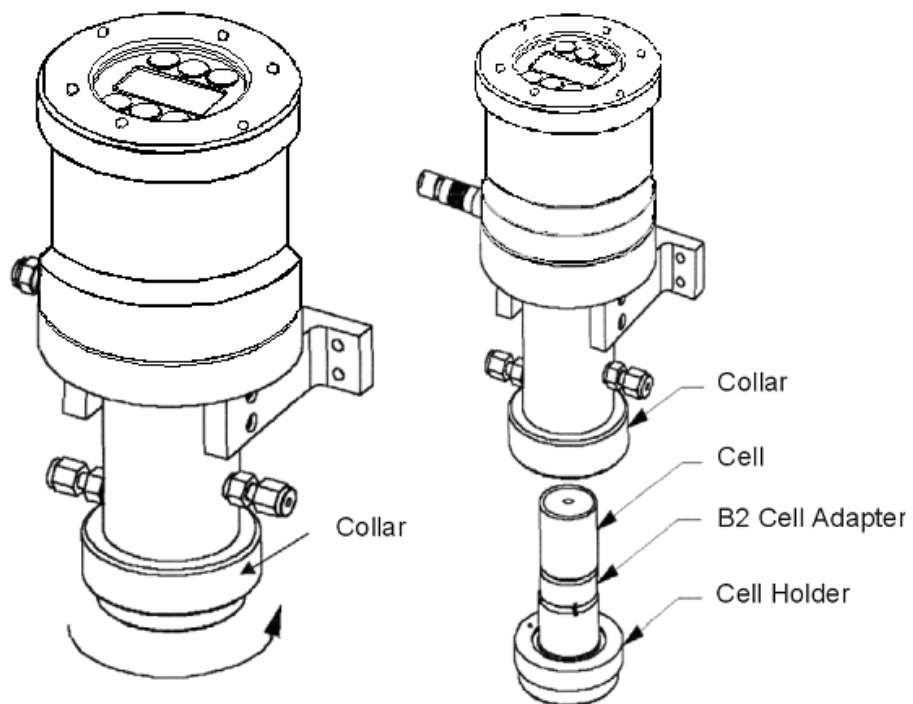

Figure 5-2: Cell Removal Insta-Trace

Appendix

Specifications

System Enclosure: Weather resistant, bulkhead mounted

Power Requirements: 15V nominal, reverse polarity protected.
9.3VDC-30VDC. V_{\min} dependent upon
safety barrier and/or load resistor used.

For Factory Mutual Approved Intrinsically
Safe Operation, an approved safety barrier
must be used. Ref. D-73226

For BASEEFA (ATEX) approved
operation, an approved safety barrier must
be used. Ref. D73736.

Ranges: 0–10ppm through 0–25% Oxygen

Accuracy: $\pm 2\%$ of full scale at constant temperature
and pressure (at the temperature and
pressure of calibration), except $\pm 1\text{ppm}$ on
0–10ppm range.

$\pm 5\%$ of full scale over operating
temperature range (once thermal
equilibrium has been reached), except $\pm 1\text{ppm}$ on 0–10ppm range.

Response Time (90%): Sensor Response Time + Electronic
Response Time = 40 seconds @ 77°F
(25°C)—(with standard cell)

Operating Temperature: 32–122°F (0–50°C)

Relative Humidity: 0-100% RH, NEMA-4 rated.

Stability: $\pm 1\%$ in 24 hours (at constant temperature)

Reproducibility: $\pm 1\%$ of full scale at constant temperature

Specifications (Cont'd)

Sensor Type: Micro-fuel Cell class B2C, L2C, B1, A2C, A5, Insta-Trace

Signal Output: 4–20 mA DC

Recommended Spare Parts List

Qty.	Part Number	Description
1	B617	IS Safety Barrier MTL 7787+
1	B616	IS Safety Barrier MTL 787S+
1	B604	IS Safety Barrier (Galvanic MTL 5041)
1	B49	IS Safety Barrier MTL5541
1	B50	IS Safety Barrier MTL4541
1	B78606	Electronics Subassembly
1	B84454A	Electronics Subassembly (Std.)
1	B84454B	Electronics Subassembly (A5 Sensor Opt.)
1	B66378	Cell Adapter (B1, B2C, A2C) Insta-Trace Opt.
1	B71625-A	Interconnection Cable Assembly (24")
1	B71625-D	25" Power/Signal Cable
1	B71475	Cell Adapter (B1, B2C, A2C) Std.
1	B71875	Insta-Trace Sensor (Std. B2C Type)
1	B73016	Insta-Trace Sensor (A2C, CO2 Type)
1	C6689-B1C	Micro-fuel Cell, Percent
1	C6689-A2C	Micro-fuel Cell, Trace, CO2
1	C6689-B2C	Micro-fuel Cell, Trace
1	CP2070	Connector, Power Signal
2	O290	O-Rings
1	B70986	Standard Cell Holder (STSTL)
1	B72087	Insta-Trace Cell Holder Cap (STSTL)
1	B74086	Cell Holder Cap (POMALUX CN-F)
1	B74085	Insta-Trace Cell Holder Cap (POMALUX CN-F)

Note: Orders for replacement parts should include the part number (if available) and the model and serial number of the instrument for which the parts are intended.

Orders should be sent to:

TELEDYNE Analytical Instruments

16830 Chestnut Street
City of Industry, CA 91748

Phone (626) 934-1500, Fax (626) 961-2538

Web: www.teledyne-ai.com
or your local representative.

Drawings

C77482-A	Outline Diagram
C77482-B	Outline Diagram
B-71625	Connector Assembly
A-71629	Interconnection Diagram
D-73736	Interconnection Diagram , ATEX with barriers

4

3

2

1

NOTES: UNLESS OTHERWISE SPECIFIED.

1) ALL DIMENSIONS ARE IN INCHES (± 0.06) AND MILLIMETERS (± 1), INCHES (mm)

2) NOT USED WHEN 1/2 NPTF PORT IS REQUIRED.

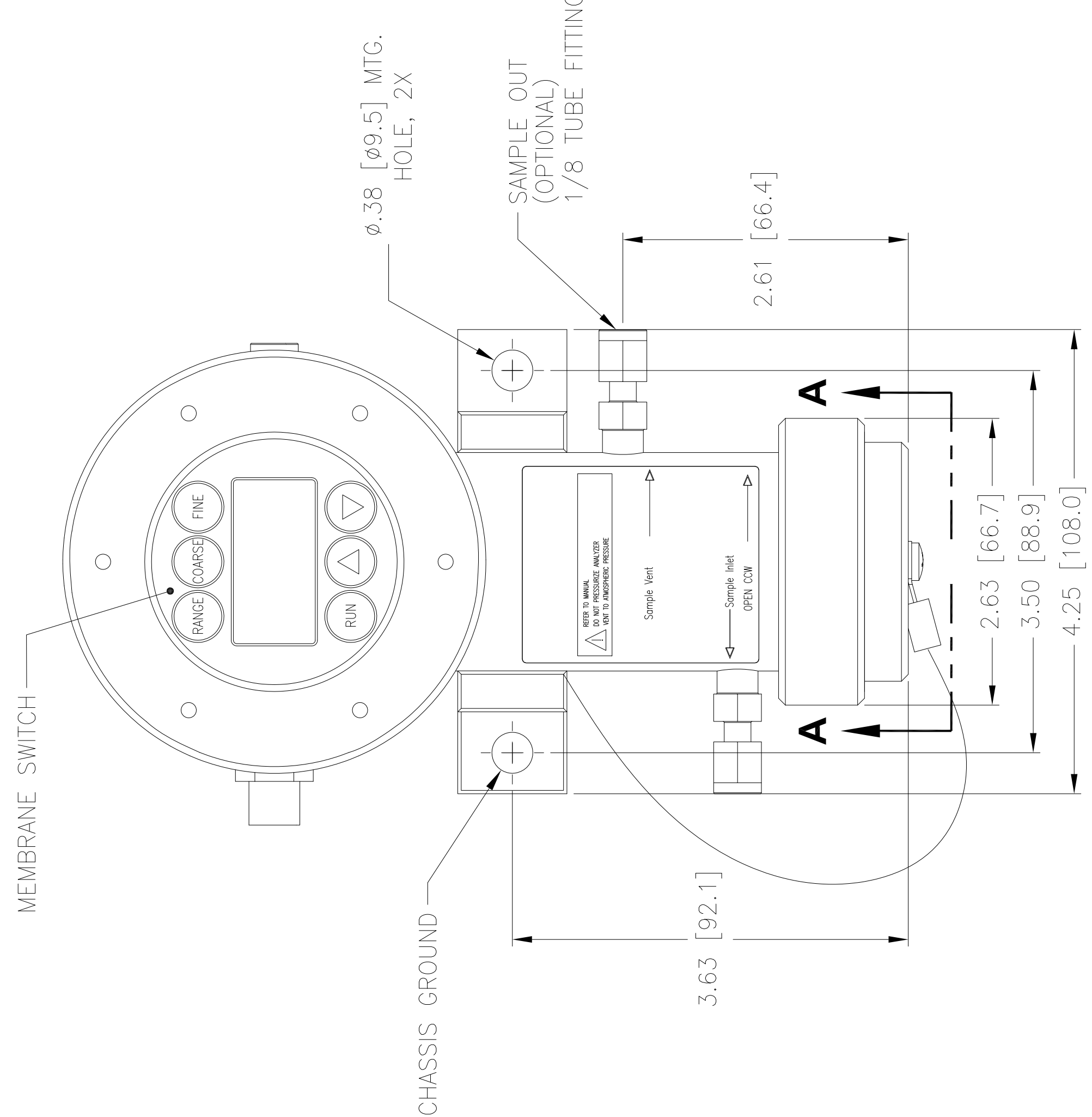

ATEX Certified Product
No modification permitted
without the approval of the
Authorized Person

REVISIONS				
REV	DESCRIPTION	DATE	APP.	REV. BY
0	Initial Release per ECO 04-0252	11/12/04	KFP	--
1	INC. ECO 05-0099	06/17/05	AA	MN
2	INC. ECO 10-0097	5/20/10	JCR	JCR

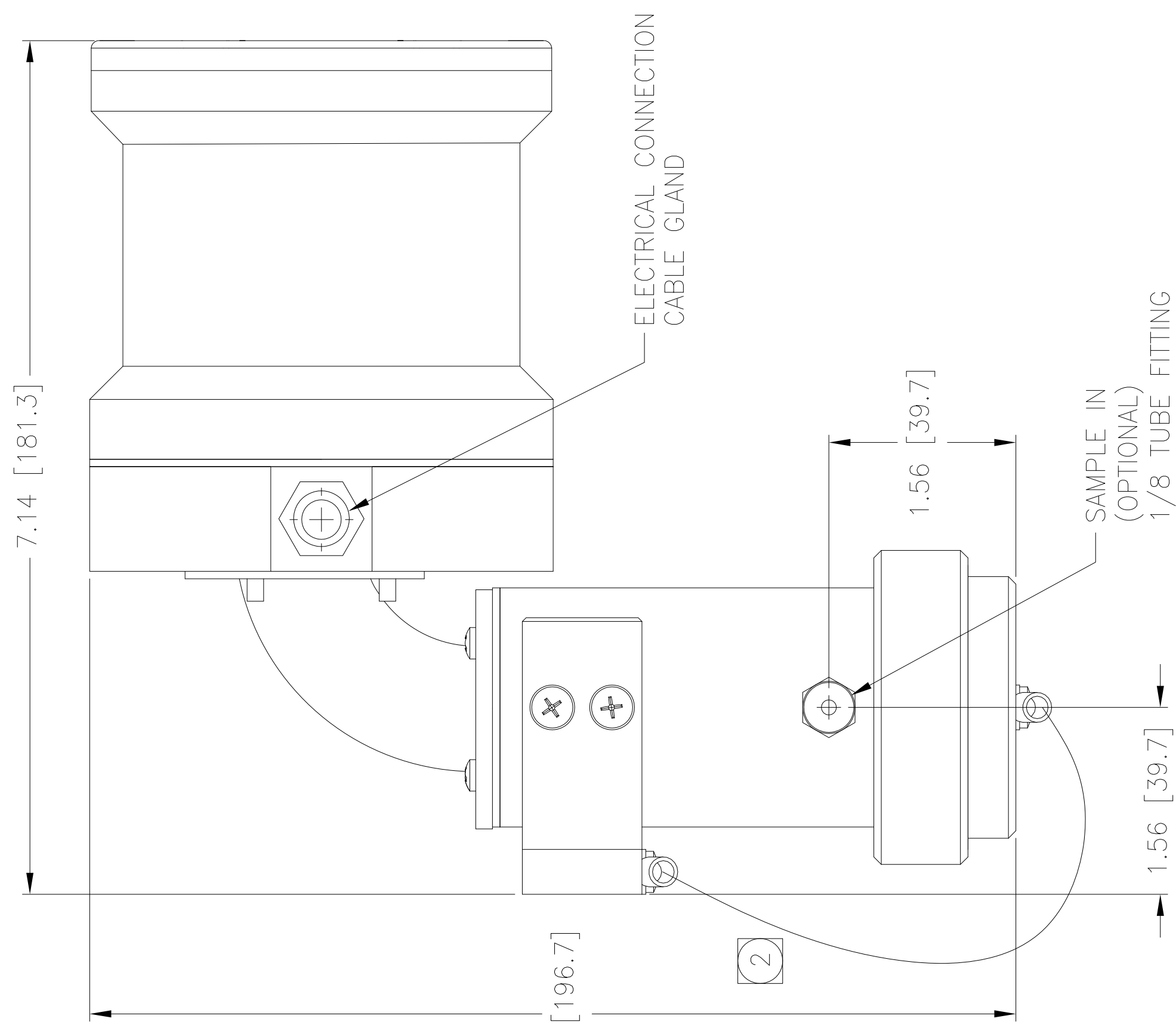

UNLESS OTHERWISE SPECIFIED DIMENSIONS ARE IN INCHES TOLERANCE		TELEDYNE INSTRUMENTS <i>Analytical Instruments</i> A Teledyne Technologies Company City of Industry, California, 91748, USA	
ANGULAR $\pm 1/2^\circ$ LINEAR $\begin{cases} X & = \pm .1 \\ .XX & = \pm .02 \\ .XXX & = \pm .010 \end{cases}$		THIS DRAWING IS THE PROPERTY OF TELEDYNE INSTRUMENTS AND CONTAINS CONFIDENTIAL INFORMATION. IT IS NOT TO BE COPIED, REPRODUCED OR USED WITHOUT WRITTEN PERMISSION.	
S/	SIGNATURES	DATE	TITLE
I/	DRFT: KFP	12/12/04	SCALE 1:1
N/	CHK:		SIM
P/	APPR:		SHEET 1 OF 1
O/	ENGR: KARL PENSON		REV
F/ C-73994	C.O.: STANDARD		DWG NO. C-77482B
REFERENCE	CAD ID C77482B2		2

A

B

C

D

4

3

2

1

4

3

2

1

NOTES: UNLESS OTHERWISE SPECIFIED.

1) ALL DIMENSIONS ARE IN INCHES (± 0.06) AND MILLIMETERS (± 1), INCHES (mm)

2) NOT USED WHEN 1/2 NPTF PORT IS REQUIRED.

ATEX Certified Product
No modification permitted
without the approval of the
Authorized Person

REV	DESCRIPTION	DATE	APP.	REV. BY
0	Initial Release per ECO 04-0252	11/12/04	KFP	--
1	INC. ECO 05-0099	06/17/05	AA	MN
2	INC. ECO 10-0097	5/20/10	JCR	JCR

D C B A

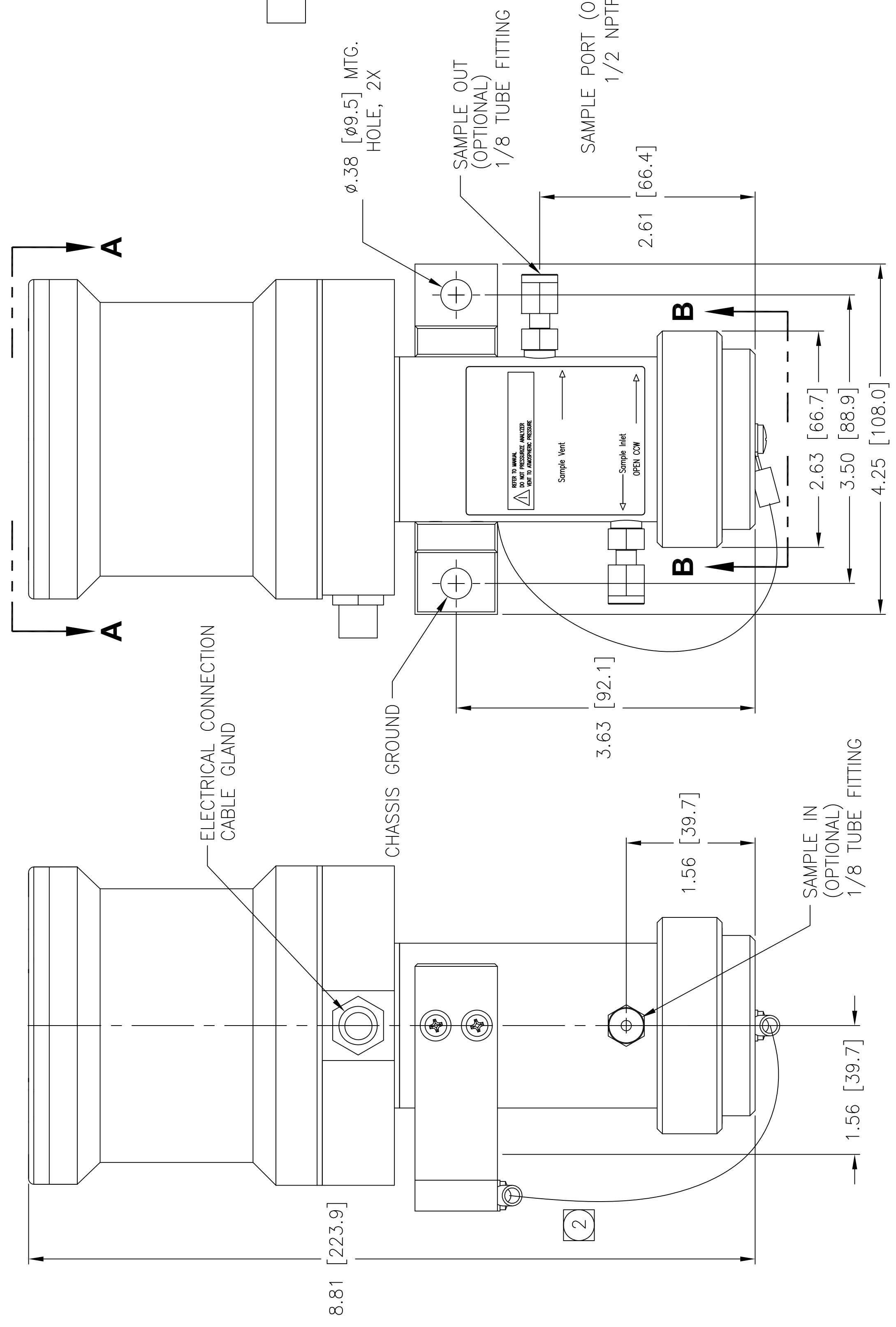

VIEW A-A

VIEW B-B

UNLESS OTHERWISE SPECIFIED DIMENSIONS ARE IN INCHES TOLERANCE [X] = ± 0.1 [XX] = ± 0.02 [XXX] = ± 0.010		UNLESS OTHERWISE SPECIFIED DATE 12/12/04	
TELEDYNE INSTRUMENTS Analytical Instruments A Teledyne Technologies Company City of Industry, California, 91748, USA		TITLE	
OUTLINE DIAGRAM TRANSMITTER UNIT (90° ANGLE) MODEL 3001 INSTA TRANS		SCALE 1:1	
S/		SIM	
I/		SHEET 1 OF 1	
N/		REV	
P/		C-77482A	
O/		DWG NO.	
F/ C-73994		MATERIAL	
REFERENCE CAD ID C77482A2		STANDARD	
ENGR: KARL PENSON		C.O.:	
APPR:		C.A.D.:	
CHK:		C.A.D.:	
DRFT: KFP		C.A.D.:	

4

3

2

1

NOTES: UNLESS OTHERWISE SPECIFIED.

1. CUT 22 AWG 2 CONDUCTOR SHIELDED CABLE TO LENGTH SPECIFIED.

OPTION	X DIMENSION
A	24 INCH
B	48 INCH
C	10 FEET
D	25 FEET

2. USE TORQUE WRENCH SET AT 2 IN. LBS. ON THE WIRE SCREWS.

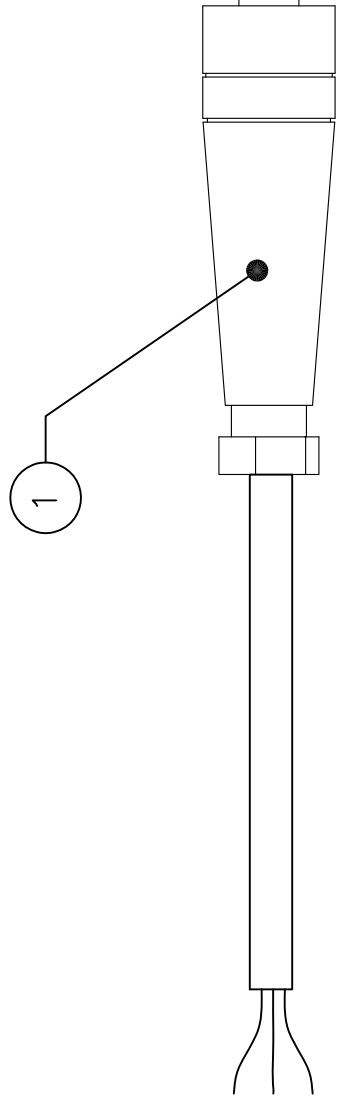
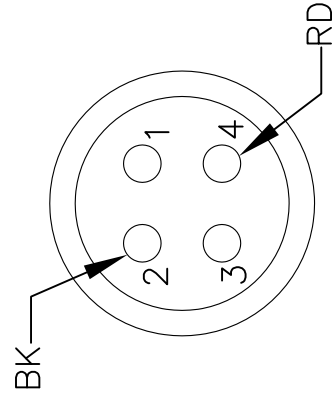
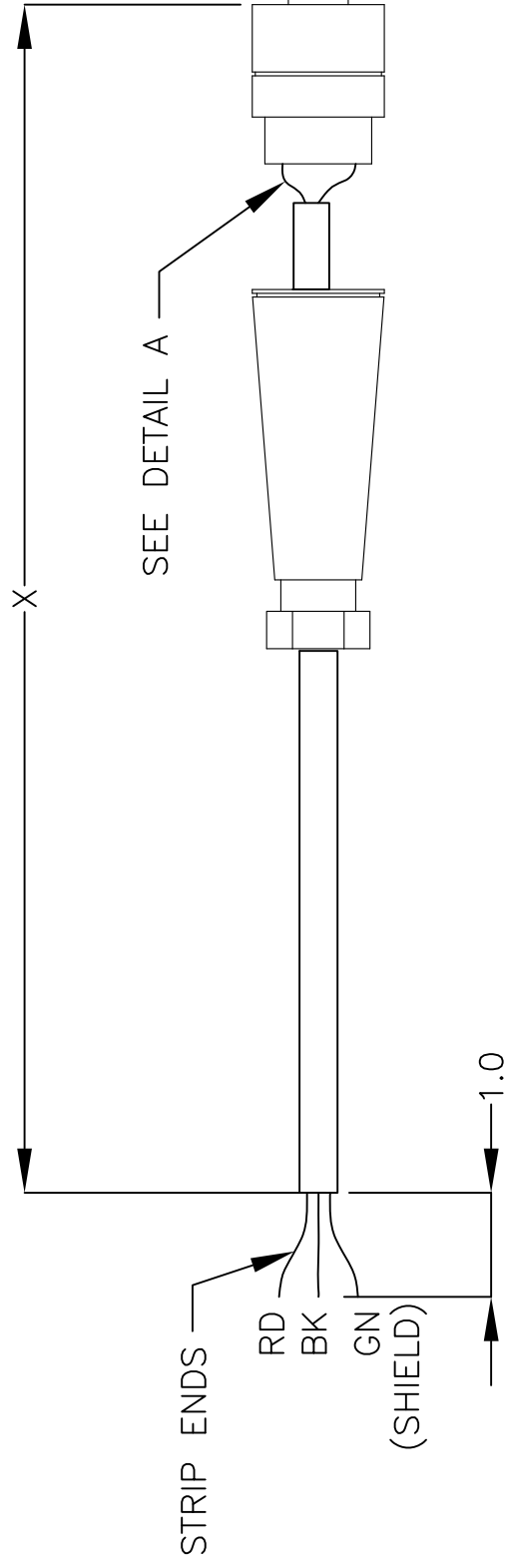

REVISIONS

REV.	DESCRIPTION	DATE	APP.	REV. BY
1	INC PER ECO# 00-0300	09/05/00	KFP	--
2	INC PER ECO# 00-0418	12/18/00	KFP	JCR
3	INC PER ECO# 13-0042	4/25/13	AA	VF
4	INC PER ECO14-0101	5/11/15	AA	VF

2	REF	B71625-RS	ROUTE SHEET
1		CP 2070	CONNECTOR, 4 PIN
ITEM	QTY.	PART NO.	DESCRIPTION

DO NOT SCALE DRAWING
TOLERANCE UNLESS OTHERWISE SPECIFIED: ANGULAR ±1/2°
LINEAR { .X = ± 0.1
.XX = ± 0.02
.XXX = ± 0.010

Teledyne Analytical Instruments
A business unit of Teledyne Instruments Inc.
CITY OF INDUSTRY, CALIFORNIA 91748, USA

SIGNATURES	DATE	TITLE
DRFT: JEREMY MARSH	2/4/00	
CHK:		
APPR:		
ENGR: KARL PENSON		
S.O.: 018414		
CAD I.D. B71625-4		

DETAIL A
SCALE 2:1

SCALE 1:1	
SIM	
SHEET 1 OF 1	
MATL.	DWG NO. B-71625
SEE NOTE 1	REV 4

CONNECTOR ASSEMBLY
MODEL INSTA TRANS

REVISIONS			
REV	DESCRIPTION	DATE	APP. BY
0	IR PER ECO# 00-0300	9/5/00	KFP

NOTES: UNLESS OTHERWISE SPECIFIED

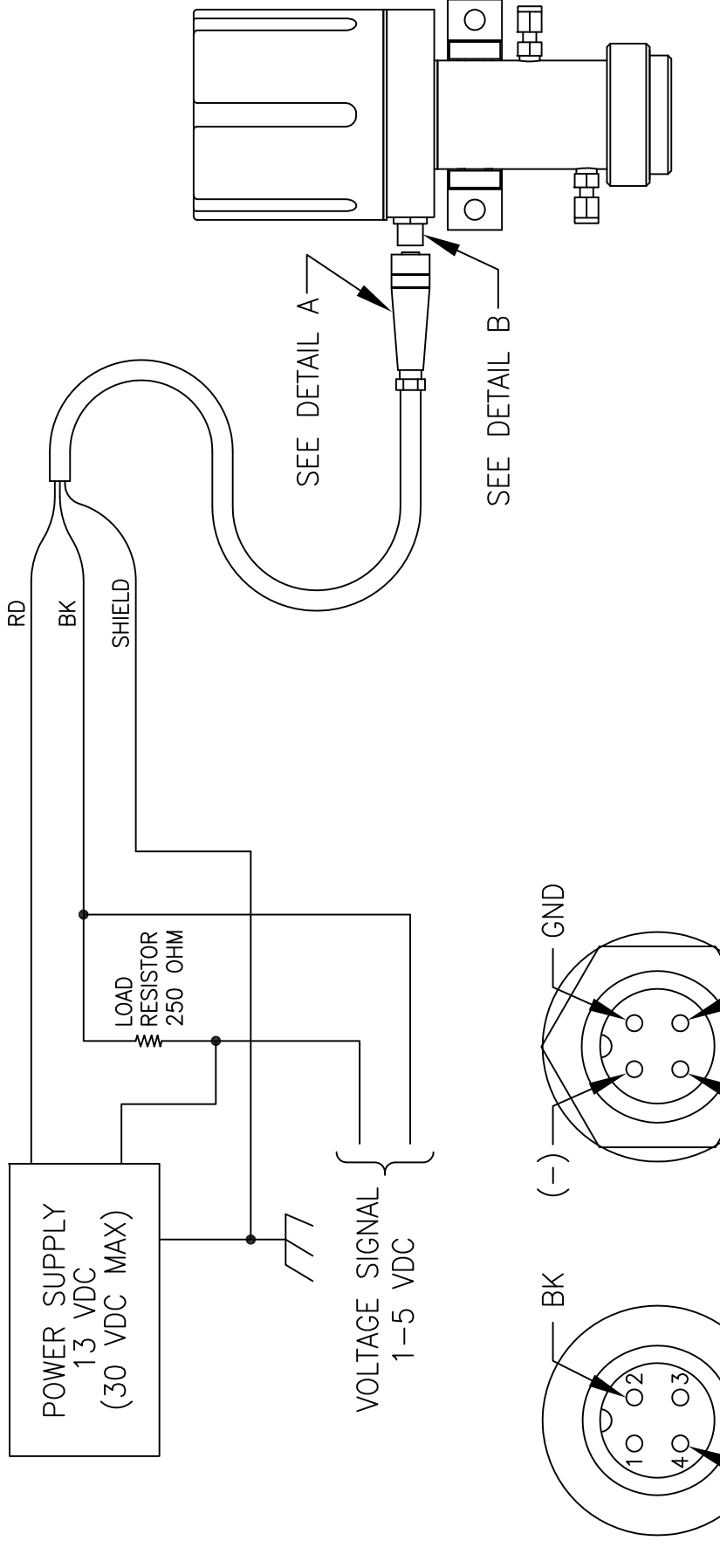

DO NOT SCALE DWG		THIS DRAWING IS THE PROPERTY OF TELEDYNE ANALYTICAL INSTRUMENTS AND CONTAINS CONFIDENTIAL INFORMATION. IT IS NOT TO BE COPIED, REPRODUCED OR USED WITHOUT WRITTEN PERMISSION.	
TOLERANCE UNLESS OTHERWISE SPECIFIED: ANGULAR $\pm 1/2^\circ$		Teledyne Analytical Instruments A business unit of Teledyne Electronic Technologies CITY OF INDUSTRY, CALIFORNIA 91748	
LINEAR [.X] = $\pm .1$ [.XX] = $\pm .02$ [.XXX] = $\pm .010$		TITLE INTERCONNECTION DIAGRAM TRANSMITTER UNIT MODEL 3001 INSTA TRANS	
SIGNATURES	DATE	SCALE	NONE
DRFT: J. MARSH	2/4/00	SIM	NONE
CHK:		SHEET	1 OF 1
APPR:		MATL.	NONE
ENGR: KARL PENSON		DWG NO.	A-71629
C.O.: 018414		REV	0
CAD I.D. A71629-0			

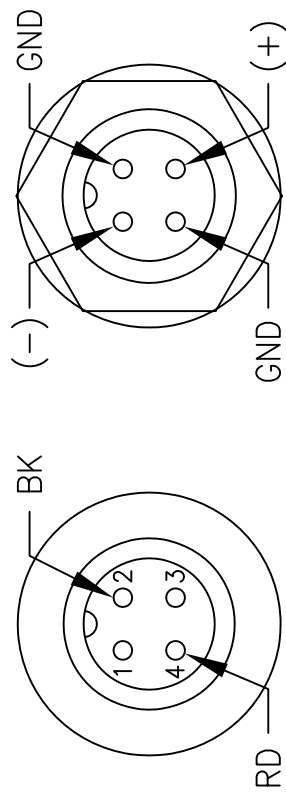

D

NON HAZARDOUS (SAFE AREA)

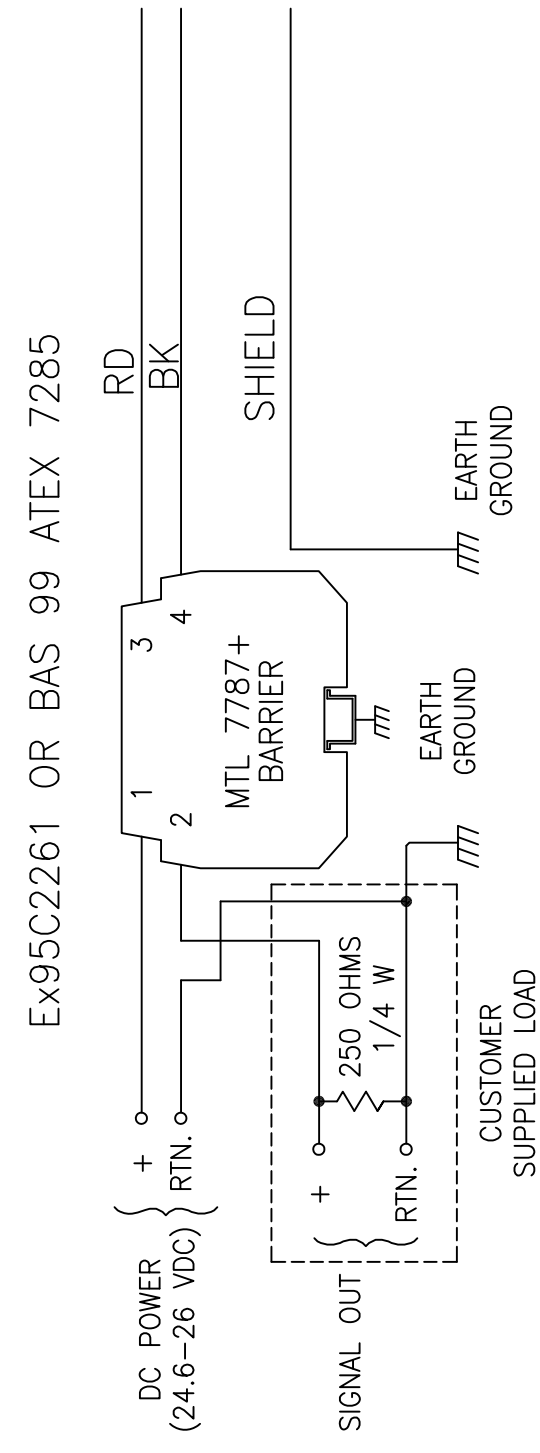
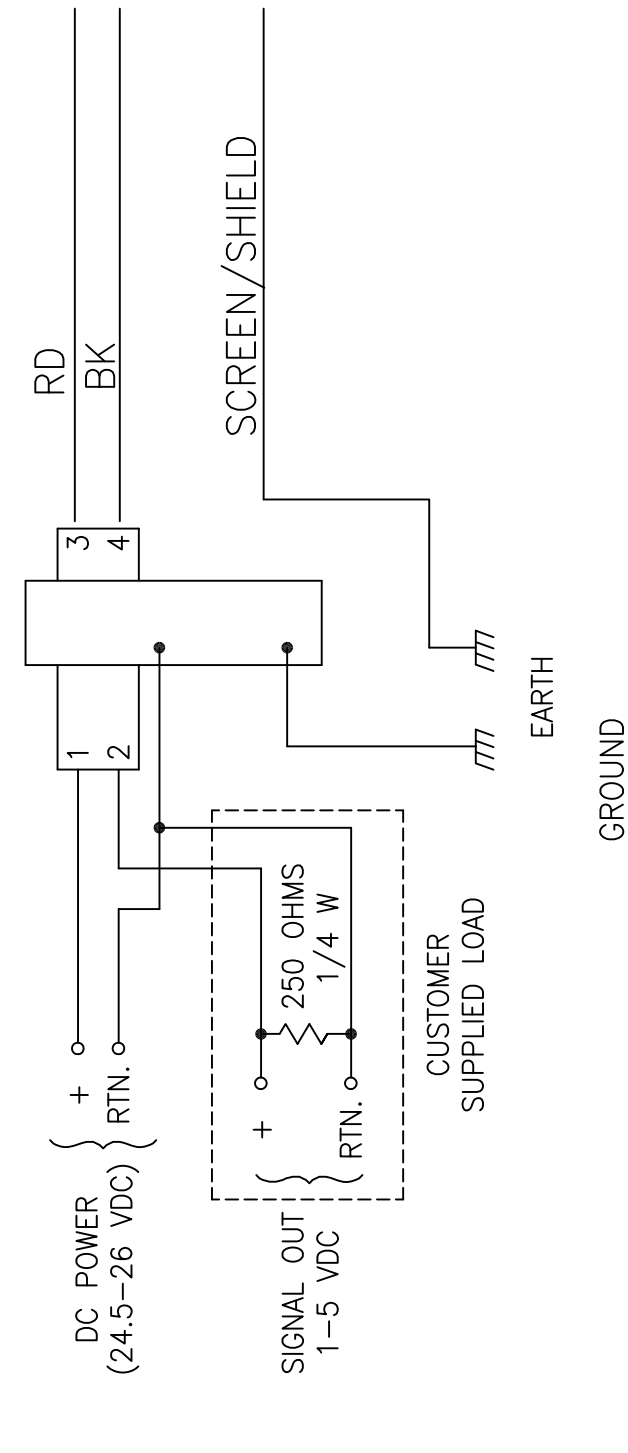
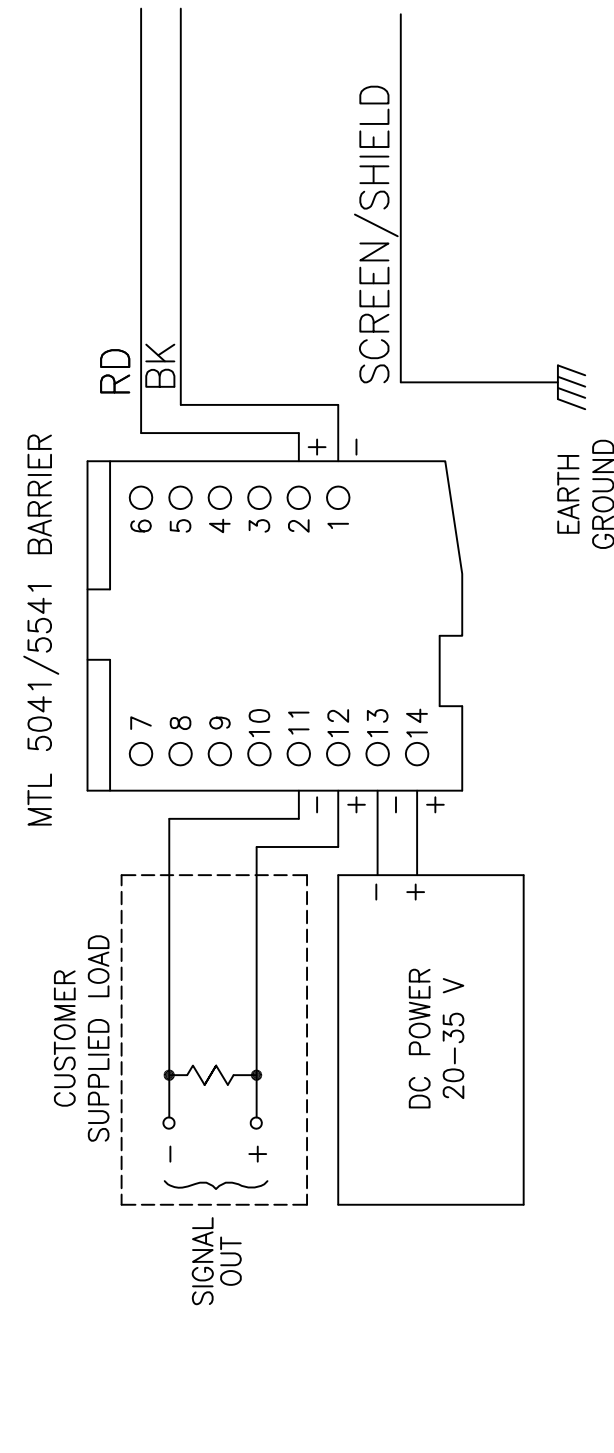
Ex 832452 OR BAS01 ATEX 7202
MTL 787S+ BARRIEREx95D2339
MTL 5041/5541 BARRIER

MTL 4541 BARRIER

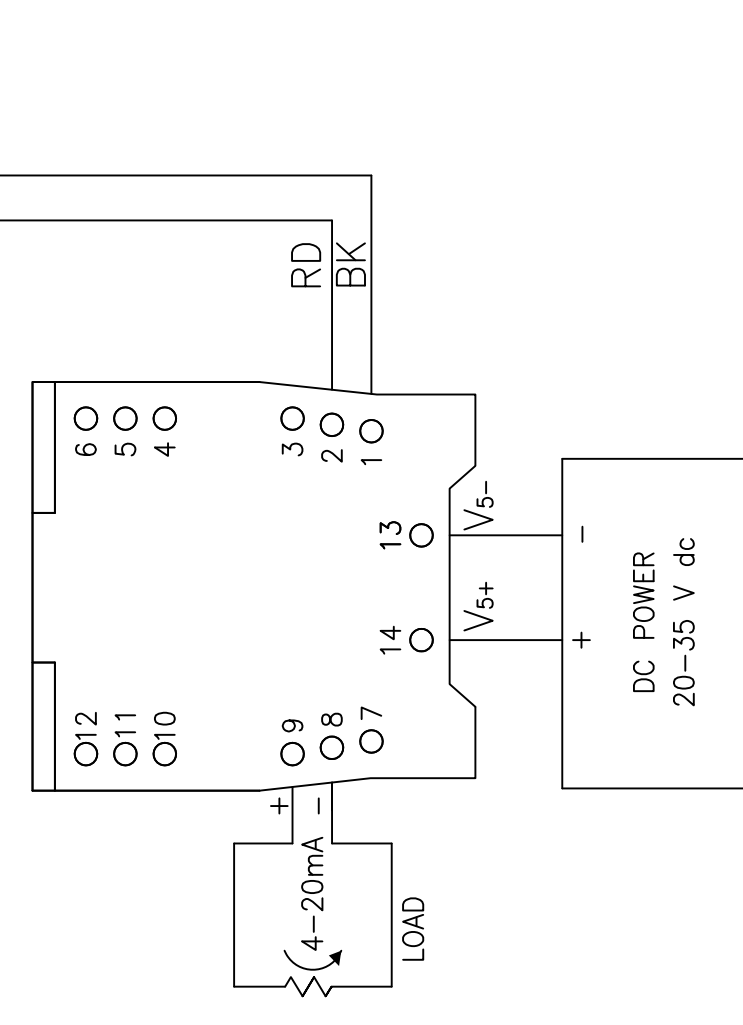

HAZARDOUS AREA

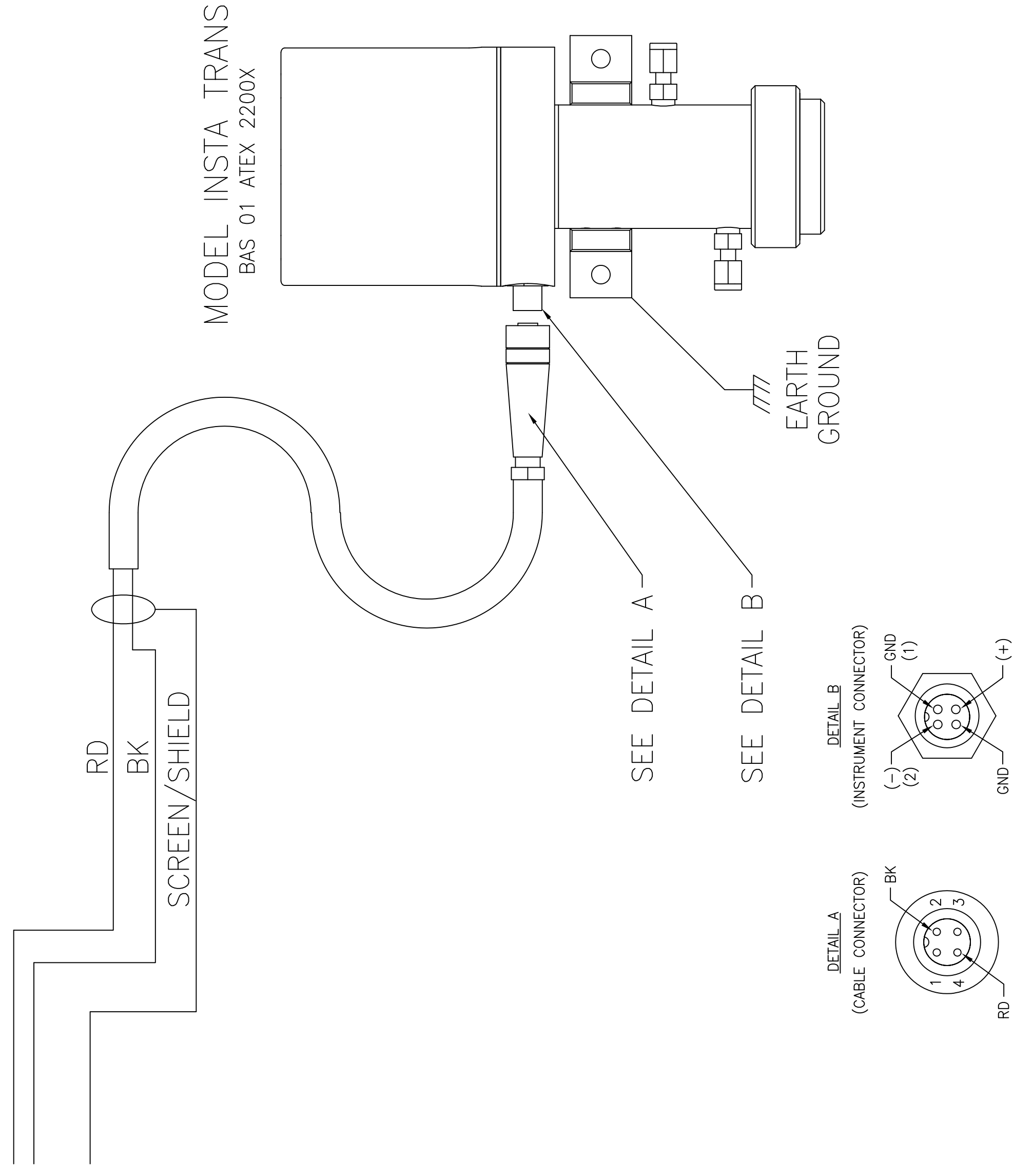

ATEX Certified Product
No modification permitted
without the approval of the
Authorized Person

REV	DESCRIPTION	DATE	APP.	REV.
0	RELEASE ECO 01-0243	12/20/01	KFP	--
1	INC. ECO 05-0089	06/17/05	AA	MIN
2	INC. ECO 10-0131	8/2/10	AA	VF
3	INC ECO 15-0004	3/6/15	AA	VF

10. THE APPARATUS IS CAPABLE OF WITHSTANDING A 500V R.M.S. AC VOLTAGE TEST BETWEEN IT'S CIRCUIT AND IT'S ENCLOSURE FOR ONE MINUTE.

9. THE CABLE SCREEN/SHIELD MUST NOT BE CONNECTED TO THE INSTA TRANS.

8. THE CABLE SCREEN/SHIELD MUST NOT BE CONNECTED TO EARTH/GROUND IN THE HAZARDOUS AREA.

7. THE SYSTEM IS TO BE MARKED IN A "STRATEGIC" POSITION WITH AT LEAST THE FOLLOWING: BAS NUMBER EX 01E2324 SYST

6. RECOMMENDED WIRE: 20 AWG SHIELDED.

5. THE SAFE AREA TERMINALS OF THE MTL 7787, 787S, 5041, 5541 AND 4541 BARRIERS MUST NOT BE CONNECTED TO ANY DEVICE THAT IS SUPPLIED FROM OR CONTAINS IN NORMAL OR ABNORMAL CONDITIONS, A SOURCE OF POTENTIAL WITH RESPECT TO EARTH/GROUND EXCESS OF 250 VRMS OR D.C.

4. THE INSTALLATION, INCLUDING THE BARRIER EARTHING/GROUNDING ARRANGEMENT, MUST COMPLY WITH THE NATIONAL REQUIREMENTS OF THE COUNTRY OF USE (E.G. IN THE UK BS 5345: PART4: 1977 OR BS EN 60079-14).

3. THE MINIMUM SAFETY BARRIER SERIES RESISTANCE IS GREATER THAN 300 OHMS.

2. THE HAZARDOUS AREA CIRCUIT MUST BE CAPABLE OF WITHSTANDING AN AC VOLTAGE TEST OF 500V R.M.S. TO EARTH/GROUND FOR ONE MINUTE.

1. THE CAPACITANCE AND EITHER THE INDUCTANCE OR INDUCTANCE TO RESISTANCE RATIO OF THE CABLE INTERCONNECTING THE INSTA TRANS AND THE BARRIER MUST NOT EXCEED THE VALUES IN THE FOLLOWING TABLE:

GROUP	CAPACITANCE in μF	INDUCTANCE OR L/R RATIO in $\mu\text{H}/\text{ohm}$
IIC	0.072	3
IIB	0.238	9.1
IIA	0.653	24
		54
		162
		432

NOTES: UNLESS OTHERWISE SPECIFIED.

ITEM	QTY	PART NO.	DESCRIPTION
BILL OF MATERIAL			
DO NOT SCALE DRAWING			
UNLESS OTHERWISE SPECIFIED			
DIMENSIONS ARE IN INCHES			
TOLERANCE: ± 0.1			
ANGULAR: $\pm 1/2$ LINEAR: XX = ± 0.01			
LVAL = 2.010			
SIGNATURES		DATE	TITLE
N/	DRFT: KFP	08/14/01	
I/	CHK:		
O/	APPR:		
P/	ENGR: KFP		
F/ C73994	C.O. STANDARD		
REFERENCE	CAD ID: D73738-3		
AS LISTED			DWG NO. D-73736
ATEX 3001 Insta Trans Interconnection Diagram with Safety Barriers			SCALE none
SM D73226			SHEET 1 OF 1
REV			3

A

8

7

6

5

4

3

2

1

8

7

6

5

4

3

2

1

D

C

B

A