OPERATING INSTRUCTIONS
FOR
Model 235 Series
THERMAL CONDUCTIVITY ANALYZER

235
236
237
238



DANGER



HIGHLY TOXIC AND/OR FLAMMABLE LIQUIDS OR GASES MAY BE PRESENT IN THIS MONITORING SYSTEM.
PERSONAL PROTECTIVE EQUIPMENT MAY BE REQUIRED WHEN SERVICING THIS SYSTEM.

HAZARDOUS VOLTAGES EXIST ON CERTAIN COMPONENTS INTERNALLY WHICH MAY PERSIST FOR A
TIME EVEN AFTER THE POWER IS TURNED OFF AND DISCONNECTED.

ONLY AUTHORIZED PERSONNEL SHOULD CONDUCT MAINTENANCE AND/OR SERVICING. BEFORE
CONDUCTING ANY MAINTENANCE OR SERVICING CONSULT WITH AUTHORIZED SUPERVISOR/MANAGER.

P/N M32845
08/06/99
ECO # 99-0323

Copyright © 1999 Teledyne Analytical Instruments

All Rights Reserved. No part of this manual may be reproduced, transmitted, transcribed, stored in a retrieval system, or translated into any other language or computer language in whole or in part, in any form or by any means, whether it be electronic, mechanical, magnetic, optical, manual, or otherwise, without the prior written consent of Teledyne Analytical Instruments, 16830 Chestnut Street, City of Industry, CA 91749-1580.

Warranty

This equipment is sold subject to the mutual agreement that it is warranted by us free from defects of material and of construction, and that our liability shall be limited to replacing or repairing at our factory (without charge, except for transportation), or at customer plant at our option, any material or construction in which defects become apparent within one year from the date of shipment, except in cases where quotations or acknowledgements provide for a shorter period. Components manufactured by others bear the warranty of their manufacturer. This warranty does not cover defects caused by wear, accident, misuse, neglect or repairs other than those performed by Teledyne or an authorized service center. We assume no liability for direct or indirect damages of any kind and the purchaser by the acceptance of the equipment will assume all liability for any damage which may result from its use or misuse.

We reserve the right to employ any suitable material in the manufacture of our apparatus, and to make any alterations in the dimensions, shape or weight of any parts, in so far as such alterations do not adversely affect our warranty.

Important Notice

This instrument provides measurement readings to its user, and serves as a tool by which valuable data can be gathered. The information provided by the instrument may assist the user in eliminating potential hazards caused by his process; however, it is essential that all personnel involved in the use of the instrument or its interface, with the process being measured, be properly trained in the process itself, as well as all instrumentation related to it.

The safety of personnel is ultimately the responsibility of those who control process conditions. While this instrument may be able to provide early warning of imminent danger, it has no control over process conditions, and it can be misused. In particular, any alarm or control systems installed must be tested and understood, both as to how they operate and as to how they can be defeated. Any safeguards required such as locks, labels, or redundancy, must be provided by the user or specifically requested of Teledyne at the time the order is placed.

Therefore, the purchaser must be aware of the hazardous process conditions. The purchaser is responsible for the training of personnel, for providing hazard warning methods and instrumentation per the appropriate standards, and for ensuring that hazard warning devices and instrumentation are maintained and operated properly.

Teledyne Analytical Instruments (TAI), the manufacturer of this instrument, cannot accept responsibility for conditions beyond its knowledge and control. No statement expressed or implied by this document or any information disseminated by the manufacturer or its agents, is to be construed as a warranty of adequate safety control under the user's process conditions.

Table of Contents

1 Introduction (Models 235, 236, 237, 238)	
1.1 Electronic Circuitry	1-2
1.2 Plug-in Circuit Boards	1-3
1.2.1 T.C. Cell Power Supply/Amplifier Board	1-3
1.2.2 Differential Power Supply Board	1-3
1.2.3 Alarm Comparator Board (optional)	1-3
1.2.4 E to I Converter Board (optional)	1-3
1.2.5 Linearizer Board (optional)	1-4
1.2.6 220 to 240 Volt Operation (optional)	1-4
2 Installation	
2.1 Location	2-1
2.2 Electrical Connections	2-1
2.3 Gas Connections	2-2
2.3.1 Reference and Zero Gas	2-2
2.3.2 Vent Lines	2-2
2.4 Pressure Regulation	2-3
2.5 Accessory Sample System Components	2-4
2.6 Recommended Flowmeter Readings	2-5
3 Operation	
3.1 Preliminary	3-1
3.2 Gas Flowrate	3-1
3.3 Zero Standardization	3-1
3.4 Span standardization	3-2
3.5 Onstream Operation	3-2
3.6 Normal Operation	3-3
3.7 Maintenance	3-3
4 Linearizer	
4.1 Theory of Operation	4-1
4.2 Output Signal Reversal	4-3
Appendix	
Spare Parts List	A-1
Calibration Data	A-2
Drawing Package	A-3



This is a general purpose instrument designed for usage in a nonhazardous area. It is the customer's responsibility to ensure safety especially when combustible gases are being analyzed since the potential of gas leaks always exist.

The customer should ensure that the principles of operating of this equipment is well understood by the user. Misuse of this product in any manner, tampering with its components, or unauthorized substitution of any component may adversely affect the safety of this instrument.

Since the use of this instrument is beyond the control of Teledyne, no responsibility by Teledyne, its affiliates, and agents for damage or injury from misuse or neglect of this equipment is implied or assumed.

Introduction (Models 235, 236, 237, 238)

The 235 Series Thermal Conductivity Analyzers measure the concentration of one component in a binary stream of gas, or the purity of a sample stream containing a composite mixture of impurities, by comparing the difference in thermal conductivity of the sample stream with that of a reference gas of fixed composition.

Control of the sample and supporting gases is not provided for in the basic design TAI offers a variety of supporting gas control panels as companion accessories to the analyzer to fill this need. In any case, means must be provided for controlling the flowrates through the sample and reference paths of the analyzer, and a control manifold will be required for the introduction of zero and span gas, as well as sample gas, into the sample path. Appropriate pressure reducing regulators will have to be installed at all gas supply sources; for those customers wishing to incorporate their own sample controls, a recommended system piping schematic is included among the drawings at the rear of the manual.

Thermal conductivity measurements are non-specific by nature. This fact imposes certain limitations and requirements. If the user intends to employ the analyzer to detect a specific component in a sample stream, the sample must be composed of the component of interest and one other gas in order to be accurate.

If, on the other hand, the user is primarily interested in the purity of a process stream, and does not require specific identification of the impurity, the analyzer can be used on more complex mixtures. The impurities, then, can be a composition in themselves.

Because analysis by thermal conductivity is not an absolute measurement, standardization gases of **known composition** will be required to fix the upper and lower parameters of the range (or ranges) of analysis. These gases will be used to periodically check the **accuracy of the analyzer**.

The difference in thermal conductivity between the fixed reference gas and the sample is sensed by hot wire elements. The elements are mounted in a cell assembly so that one set is in the reference and the other in the sample stream. Each set of elements is a component in an electrical bridge circuit.

During calibration, the bridge circuit is balanced in zero and reference gas at one end of the measurement range, and sensitized in reference and span gas at the other end, so that intervening points along the range (or ranges) of interest will produce a DC electrical signal representative of the analysis. The resulting electrical signal is fed to an amplifier and span pot, which produce a standard 0-1V output signal. An E to I converter PC board is also installed and produces an isolated 4–20 mA DC current output in addition to the voltage output.

The temperature of the measuring cell is regulated to within 0.1 degree C by a sophisticated control circuit. A thermistor is used to measure the temperature, and a zero-crossing switch regulates the power in a cartridge-type heater. Temperature control is precise enough to eliminate diurnal effects in the output over the operating ranges of the analyzer.

The overall design of the instrument is intended to facilitate servicing and troubleshooting, should that ever be necessary. The controls are all mounted on the front panel, which can swing down, allowing access to the cell compartment. The cell is enclosed in an insulated compartment that is readily removable from the chassis; the electronics are mounted on a series of circuit boards at the rear of the enclosure, accessible by removing the back panel.

Explosion-proof models of the series use sealed explosion-proof enclosures for the analysis section (Model 237) or both the analysis section and control unit (Model 238). Model 235 is general purpose with remote control unit, and Model 235 is general purpose with integral control unit.

1.1 Electronic Circuitry

The electronic components are mounted on a number of circuit boards that plug into sockets on a larger board, dubbed the “Mother Board”. This allows for rapid troubleshooting and repair of any defective parts, and also for rapid field installation of optional features not ordered with the unit.

All electrical interconnections are made to the terminal strips on the mother board; this board also contains an unusual feature — a series of regularly-spaced holes in a rectangular pattern, known as a “kludge” space, is set aside for the installation of circuitry for special customer requirements.

1.2 Plug-in Circuit Boards

Several options are available as convenient plug-in circuit boards; although these may not all be present in the specific instrument under consideration, a brief description of some of the more common ones is offered below, and noted as (optional); PC boards which are not noted as (optional) are standard features.

1.2.1 T.C. Cell Power Supply/Amplifier Board

This circuit contains an IC regulator that holds the voltage through the cell to 4.5 V. It also contains a 2-stage IC amplifier, with range resistors.

1.2.2 Differential Power Supply Board

15 Volts, regulated (for electronic amplifiers, etc.), and +24 volts, non-regulated (for alarm and relay circuitry and certain other functional uses) are supplied by this circuit.

1.2.3 Alarm Comparator Board (optional)

The comparator alarm circuit is available in single or dual configurations, which can be supplied as high or low alarms, energized above or below setpoint; adjustment of each alarm setpoint is made using a potentiometer provided on the instrument's front panel. Power failure or “fail-safe” alarming can also be provided. Refer to the specifications covering one individual analyzer for details regarding specific alarm or other optional provisions.

1.2.4 E to I Converter Board (standard)

The standard current output in the form of an isolated 4–20 mA dc current is supplied by the E to I converter circuit. The output of this board is proportional to the percentage of range, for example, 4 mA for 0% and 20 mA for 100% of range. This current output is in addition to the 0–1 V dc voltage output.

1.2.5 Linearizer Board (optional)

An excellent alternative to the use of correction curves is available as an option with the Series 235 Analyzer. A digital linearizer circuit is available as a plug-in PC board. This is a very flexible circuit that produces a linear correction to a wide variety of non-linear curves. The result is an output signal which is linear over the specified analysis range or ranges. When employed, the digital linearizer is transparent to the user and requires no adjustment.

1.2.6 220 to 240 Volt Operation (optional)

The Series 235 analyzer is available for either 110-120 (standard) or 220-240 (optional), 50 or 60 Hz operation.

Installation

2.1 Location

The analyzer should be installed where it will not be subject to the following conditions:

1. Direct sunlight
2. Drafts of air
3. Shock and vibration
4. Temperatures below 30° F or above 110° F

The analyzer should be placed as close as possible, subject to the above conditions, to the sample point to minimize the effects of sample line lag time on the analysis.

An outline diagram, showing the location and identification of the gas line and electrical conduit connections, as well as the physical dimensions of the analyzer case, is included in the drawings at the rear of the manual.

2.2 Electrical Connections

A single-phase, 110 to 120 Volt, or 220 to 240 Volt, 50 or 60 Hz line, capable of delivering 2-1/2 amperes of current continuously, is required to operate the analyzer. Primary power connections are made on the terminal strip mounted on the mother board, behind the rear access cover. A solid water-pipe ground should be provided for personnel protection. When connecting the power source, polarize the connections as indicated on the interconnection diagram at the rear of the manual.

Use 2-conductor shielded cable (nominally No. 22 wire size) to interconnect the analyzer output signal with the recording equipment. The shield should be terminated on the appropriate terminal (see interconnection diagram) at the analyzer—and be left disconnected at the recorder.

2.3 Gas Connections

Customer gas connection points are located on the underside of the analyzer case. (Standard, basic instrument)

(See Outline Diagram for identification of each point.)

2.3.1 Reference and Zero Gas

A constant supply of gas, of a fixed composition, is needed as the reference to which the sample gas will be compared. The reference gas is normally selected to represent the main background of the analysis. For certain applications, an optional sealed air reference is available where the reference side of the detector cell is filled with air and sealed. This eliminates the need to have reference gas constantly passing through the cell. For instruments equipped with the optional sealed air reference, there will not be reference inlet or vent ports.

A supply of gas, containing little or none of the components of interest, is required to zero-standardize the analyzer.

In order to satisfy the requirements, both of these gases must be supplied from purchased cylinder sources — as no other economical means is readily available that will guarantee the user that impurities are maintained at a low, fixed level.

Because most cylinder gases are supplied 99.95 to 99.98% pure, TBE recommends that one cylinder of gas be used to fill both needs for most applications (i.e., zero and reference.)

Specific recommendations as to the number and type of supporting gases required will be found listed in the calibration section of the manual.

It is essential to the accuracy of the analyzer that the purity of the zero gas be known. The zero control would be adjusted during zero standardization, so that the recorder indicates the impurity content of the zero gas, rather than zero.

2.3.2 Vent Lines

The selected gas introduced into the sample path of the cell (zero, span, and sample) is vented from one connection at the bottom of the analyzer, and the reference gas is vented from another.

If it is desirable to carry these gases to an area remote from the analyzer to vent them, the following precautions will have to be observed in vent line installation:

1. The vent lines should be constructed of 1/4 inch tubing, so that no appreciable back pressure resulting from restricted flow is experienced by the analyzer.
2. Both the sample and reference lines must be vented into an area where the ambient pressure is the same.
3. The ambient pressure in the vent area must undergo no more than normal barometric pressure changes.
4. The vent lines must be installed so that water and dirt cannot accumulate in them.

2.4 Pressure Regulation

All incoming gas lines should be equipped with pressure regulators.

The sample line pressure regulator should be installed as close to the sample point as possible to minimize sample line lag time.

Sample pressure should be set somewhere between 5 and 50 psig—10 psig is nominal.

To minimize flowrate adjustments, the pressure regulators on the supporting gas supply cylinders should be adjusted to provide the same output pressure as the sample line regulator.

When installing pressure regulators on supply cylinders, crack the cylinder valves so that gas is flowing during installation. Using this procedure will eliminate the most common cause of standardization gas contamination. Air trapped during assembly can, and will, diffuse back into the cylinder. This is particularly important in applications where impurities of 1 and 2% are the range of interest.

2.5 Accessory Sample System Components

An integral gas selector panel is available as an option. This panel mounts the gas controls on a panel where they can be operated conveniently

In applications where TBE furnishes an accessory gas control panel, or a completely interconnected panel or cubicle system, installation can be simply accomplished by using the supporting drawings included at the rear of the manual. However, if the customer is selecting and interconnecting his own gas system components, the following conditions should be adhered to:

1. Do not deviate from the system outlined in the piping schematic when constructing your system.
2. Select a flowmeter capable of resolving 0.08 SCFH (40 to 50 cc/min) for the reference path of the analyzer.
3. Select a flowmeter capable of resolving 0.3 SCFH (150 cc/min) for the sample path of the analyzer. (See Addendum A for recommended flowmeter readings for gases heavier or lighter than air.)

2.6 Recommended Flowmeter Readings for Gases Heavier or Lighter Than Air

Due to the wide range of applications and gases that are measured with the Thermal Conductivity Analyzer, the density of different sample gases may vary considerably; for example, air is more dense than hydrogen. When setting the sample and reference flowrate, note that gases lighter than air will have an actual flowrate higher than indicated on the flowmeter, while gases heavier than air will have a lower actual flowrate. The following chart (with hypothetical figures) illustrates this fact:

GAS	FLOWMETER READING	ACTUAL FLOWRATE
Lighter than air	0.3 SCFH	1.2 SCFH
Heavier than air	0.3 SCFH	0.2 SCFH
Air	0.3 SCFH	0.3 SCFH

The analyzer is not flow sensitive during measurement; i.e., the OUTPUT does not vary with the flow, but for maximum accuracy and repeatability, measurements should be made at the same flowrate used when calibrating the analyzer.

TBE recommends, for **lighter-than-air gas backgrounds**, setting the flowmeter to a lower reading for reference and measurement; this will conserve gas. For example, for hydrogen or **helium**, set the flowmeter reading to 0.1 SCFH. A higher reading is recommended for **heavier-than-air gas backgrounds**, e.g., for **carbon dioxide or argon**, set the flowmeter to 0.4 SCFH.

Operation

3.1 Preliminary

- Check to see that all gases have been connected to the proper ports of the analyzer and that all gas connection lines are leak-free.
- Check to see that the power and signal wiring has been properly installed.
- Check to see that the fuses in the analyzer are intact.
- Check to see that all PC Boards are intact and securely plugged in.
- Turn the recorder and power switches to the “ON” position.

3.2 Gas Flowrate

Start the **REFERENCE** gas flow, and adjust the flowrate to approximately 0.08 SCFH (40 cc/min.)

Start **ZERO** gas through the sample path of the analyzer, and adjust the flowrate to approximately 0.3 SCFH (150 cc/min).

See Section 2.6 for additional flowrate information for gases lighter or heavier than air.

Allow the analyzer to run with zero and reference gas flowing for several hours before attempting calibration. This will permit the cell to come to thermal equilibrium.

3.3 Zero Standardization

After the necessary temperature stabilization period, the analyzer can be zero-standardized as follows:

NOTE: Before zero-standardization of the analyzer is possible, and while the power is off, the mechanical zero of the meter must be checked. If the pointer does not rest at zero with the power off, then adjust the slotted screw found at a low center position of the meter face to correct. DO NOT allow this screw to be readjusted after the zero-standardization has been performed. No mechanical zero is used with digital meters.

1. Check to see that the span control is set at about 50% of its travel. Some readjustment of this control may be necessary during standardization, but our concern at this point is to see that a reasonable level of output signal is available to the recorder for zero standardization.
2. With multi-range analyzers, make sure that the range selection switch is on the "Range 1" position. As in Step No. 1, this insures a proper signal level for deriving a correct zero setting.
3. Check the sample path flowmeter to see that the zero gas flowrate is 0.3 SCFH.
4. Adjust the Zero control on the analyzer control panel until the meter indicates the impurity (if any) contained in the zero gas.

3.4 Span Standardization

After the zero setting has been accomplished, the span (or sensitivity) of the analyzer can be checked as follows:

1. Arrange the sample path so that span gas is flowing through the analyzer.
2. Check the sample path flowmeter to see if the span gas is flowing at a 0.3 SCFH rate.
3. With multi-range instruments, set the range selector switch on the position that provides the highest resolution of the span gas concentration.
4. Adjust the span control until the meter reads the correct value of impurity in the span gas.

3.5 Onstream Operation

After standardization has been successfully concluded, arrange the sample path so that sample gas is flowing through the analyzer at approximately 0.3 SCFH.

With multirange instruments, select the range of analysis that gives the best recorder resolution of the process stream. The analyzer is now "onstream" and ready for use.

3.6 Normal Operation

For routine operation of the analyzer, you should perform the following checks:

- **Sample flow:** Check the sample flowrate daily to insure proper operation.
- **Reference gas flow:** Check the reference gas flowrate daily—and the reference supply cylinder periodically—to insure against accidental depletion. Whenever it is necessary to replace the reference gas supply, the analyzer standardization procedures must be repeated.
- **Standardization:** The analyzer should be restandardized on a monthly schedule as a check of its performance.

3.7 Maintenance

Since there are no moving parts in the analyzer, no routine maintenance is required other than normal care of the instrument. The checklist above should be adequate to keep the analyzer functioning properly for many years.

Linearizer

4.1 Theory of Operation

The need for an electronics linearizer circuit arises in those applications where the output of an instrument is not linearly related to the parameter the instrument tries to measure. Often, this is the concentration of a chemical of interest, color values, absorbance, or transmittance. When the calibration curve, which is a plot of concentration versus instrument signal output, is not a straight line, the linearizer can correct the curve and make it approach a straight line. The linearizer does this by dividing the curve into eight sections. Each section is amplified and added to the previously corrected section.

Each section has a “breakpoint”, which connects it to the next section away from zero; zero is the starting point of the curve. (Refer to Figures 4-1, 4-2, and 4-3.) The error left after linearization is due to the curvature of each individual section. This error can be made quite small by correct selection of the breakpoints. The output of the linearizer is 0-1 Volt. See Figure 4-4 to visualize the linearization process.

Figure 4-5 shows how the linearizer works in actuality. It is exaggerated for clarity. For segment 1, the output will be some number (or fraction) times the input voltage:

$$V_{\text{out}} = 0.8 \times V_{\text{in}}$$

where V_{out} is the output voltage and V_{in} is the input voltage.

Here, for this example, the gain of the circuit is 0.8 for an input voltage between 0 and 0.125 Volts.

When the input voltage exceeds 0.125 Volts, the second amplifier, as well as the first, is working; it is adding or subtracting its output in proportion according to the setting of trimpot P2. In this case, its output is added to the output of the first amp. The total gain (the slope of the line segment) for the combined segment is now about 1.9.

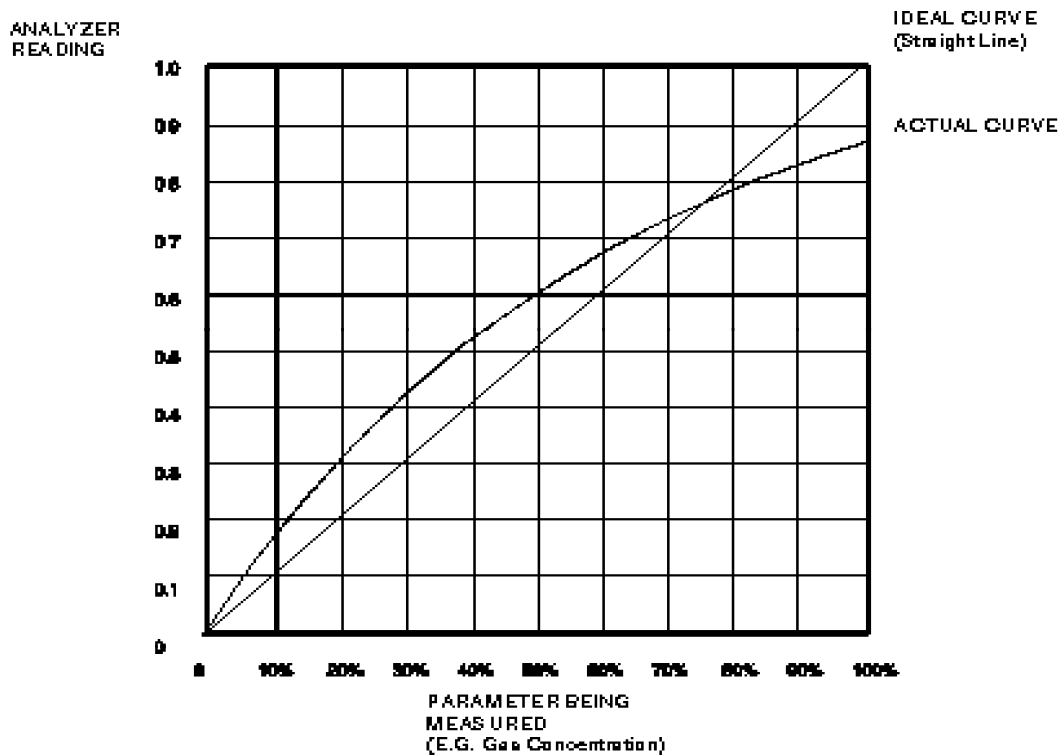

Figure 4-1a: THE PROBLEM
 The analyzer output is not directly proportional to the parameter it is supposed to measure.

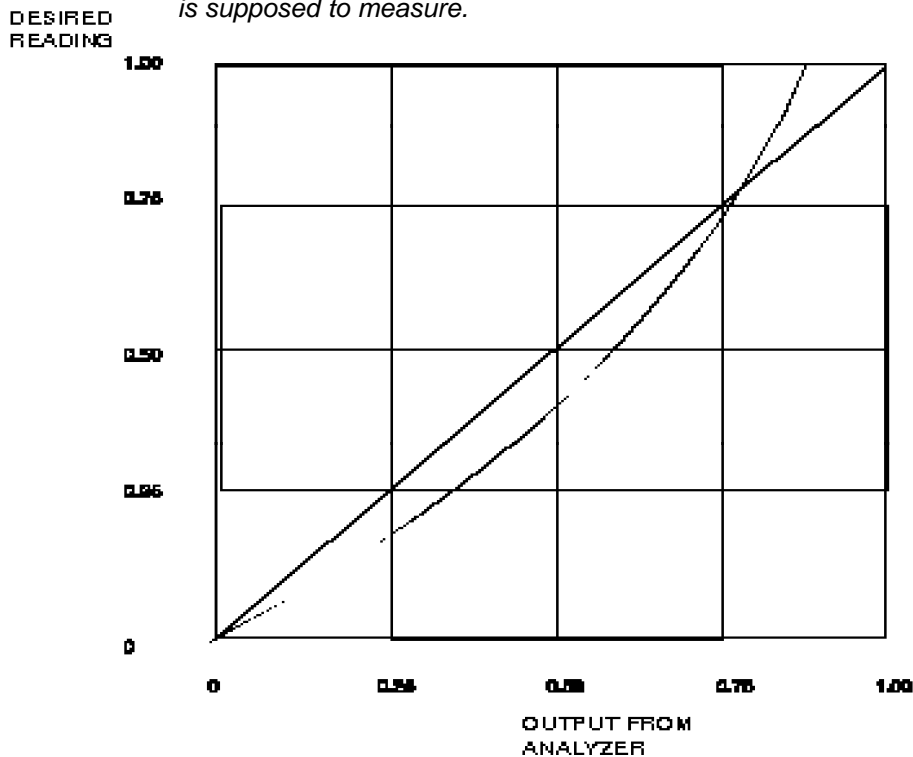

Figure 4-1b: THE SOLUTION
 The Linearizer output is proportional to its input in a complimentary fashion to the analyzer curve. As a result, the output is directly proportional to the parameter being measured.

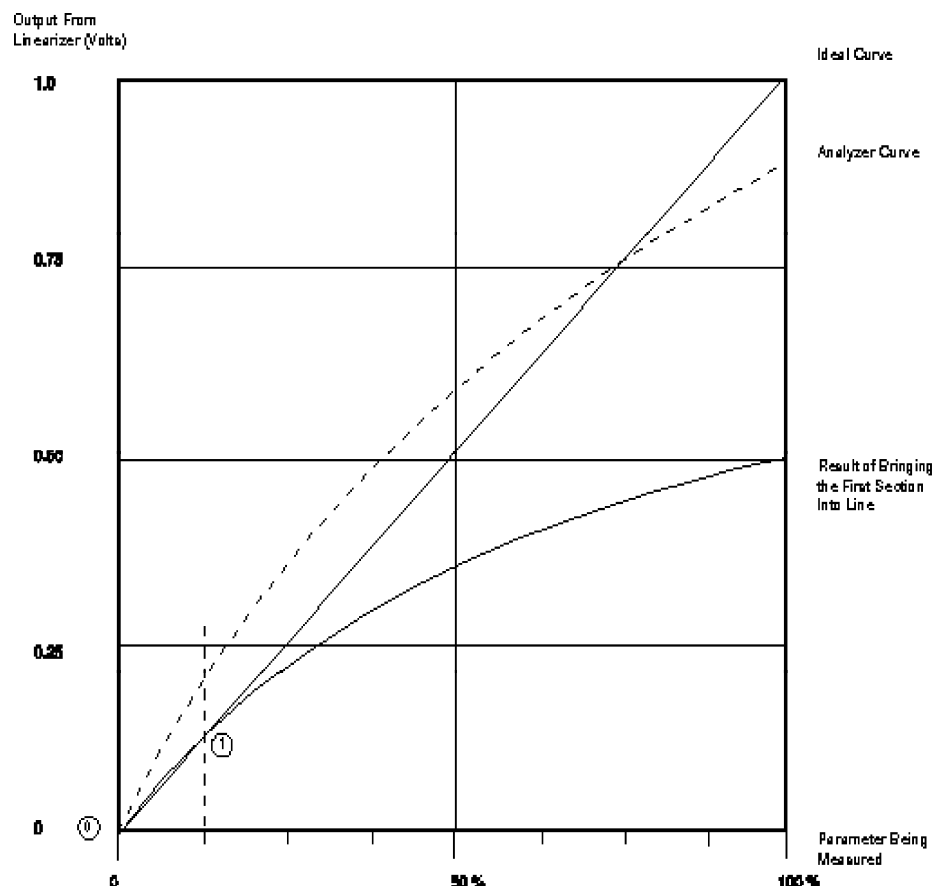

Figure 2a: THE IMPLEMENTATION - STEP 1

Adjust the gain of the first amplifier to bring the first segment (from 0 to 1) of the analyzer curve into line with the ideal curve. This produces a small error in the first section, but a larger error at higher inputs.

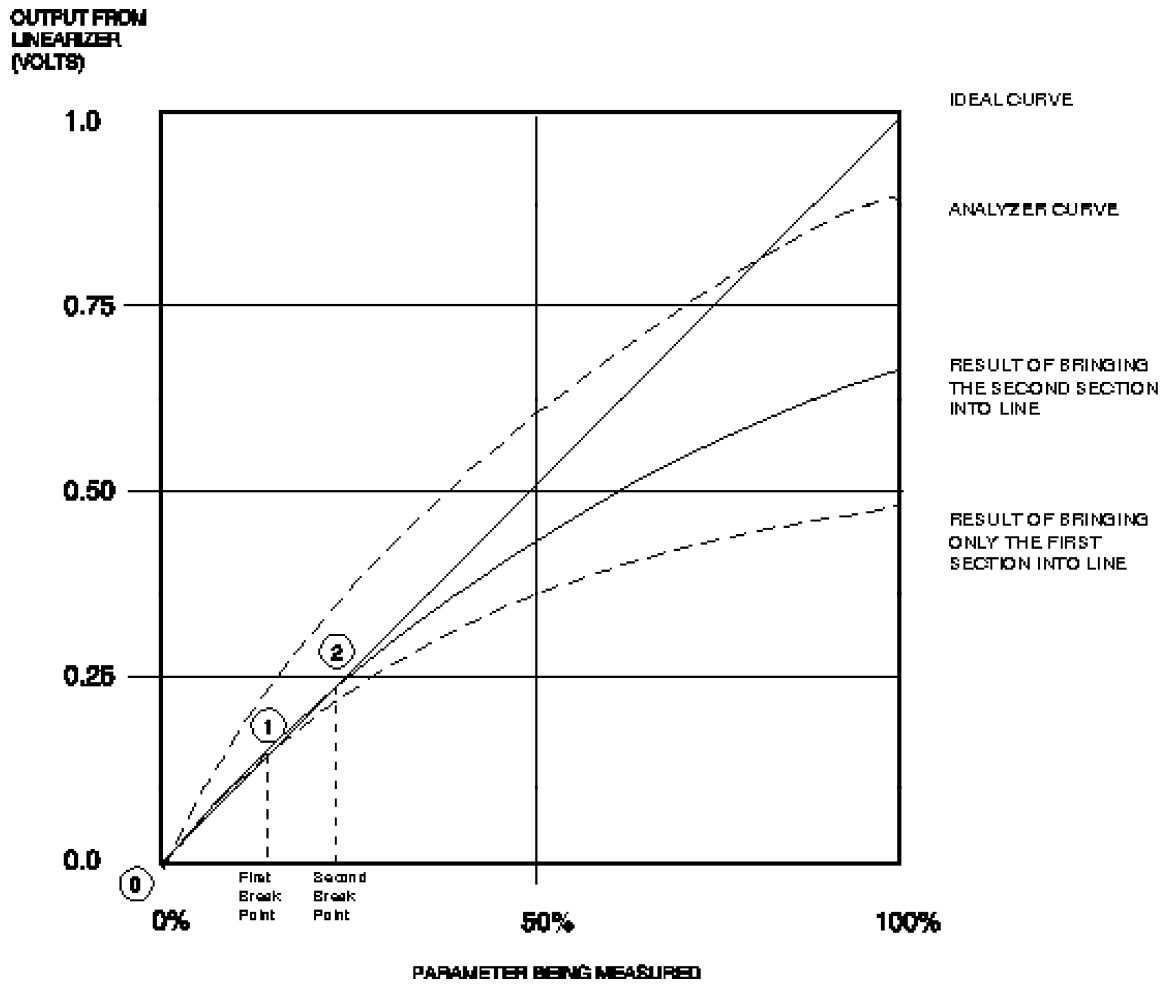

Figure 4-2b: THE IMPLEMENTATION - STEP 2

At point 1, the second amplifier begins to work in addition to the first. Its gain is adjusted so that point 2 lies on the ideal curve. The error is small until point 2 is reached. Here, the large error is due to the curvature of the original analyzer curve.

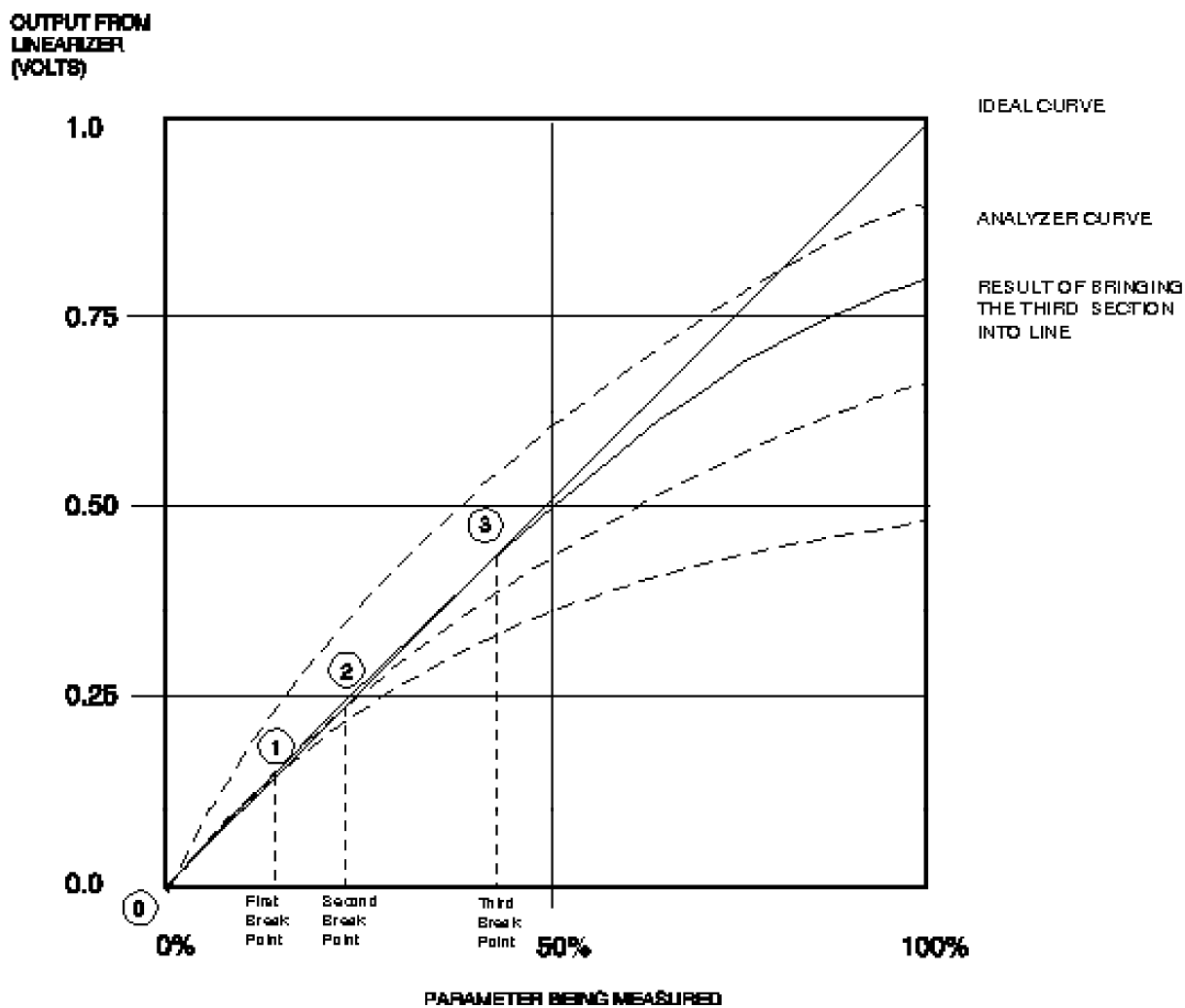

FIGURE 4-2c: THE IMPLEMENTATION - STEP 3
 At point 2, the third amplifier begins to work in addition to the first two. Its gain is adjusted so that point 3 lies on the ideal curve.

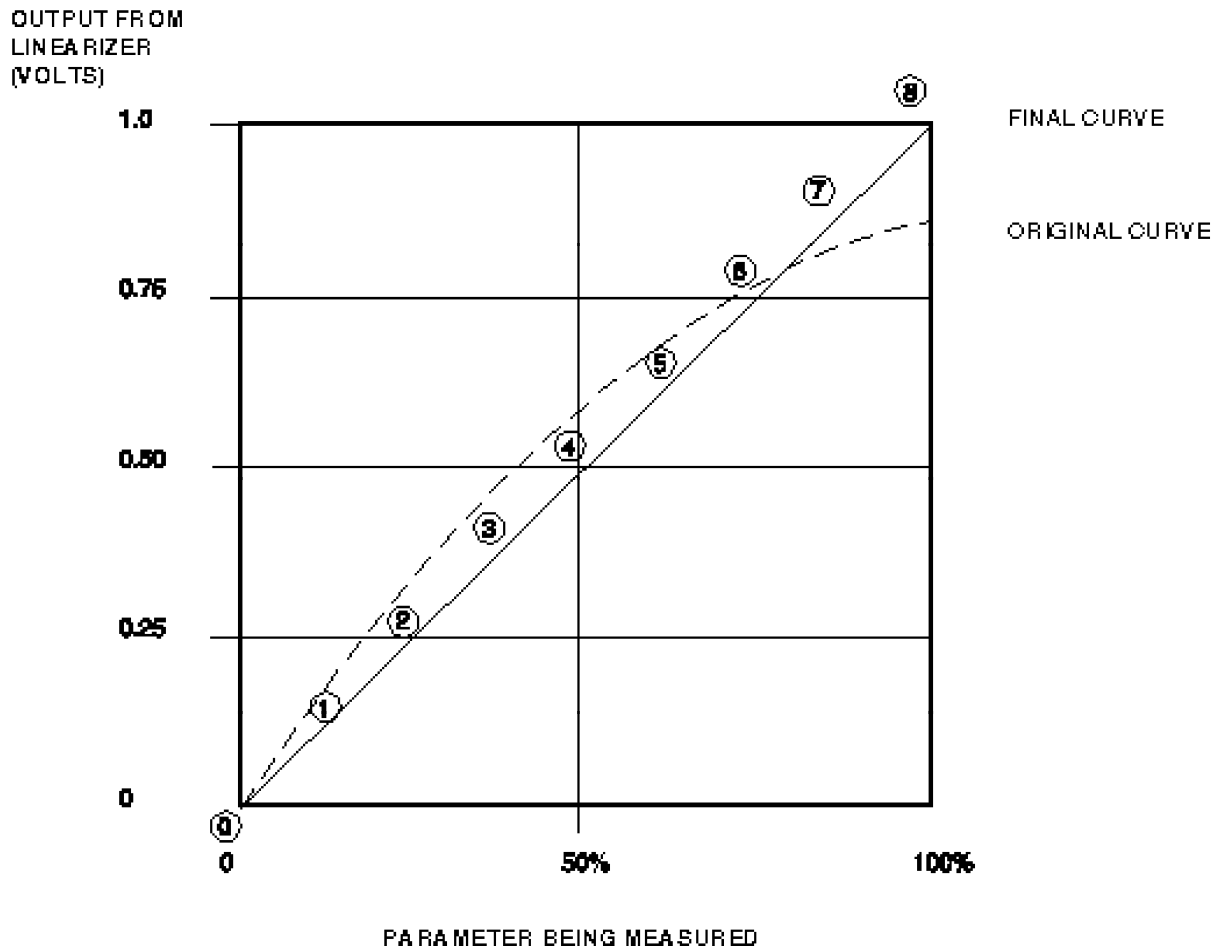

Figure 4-3: THE RESULT

By using all the line segment amplifiers, the output of the analyzer is made to be almost directly proportional to the parameter being measured.

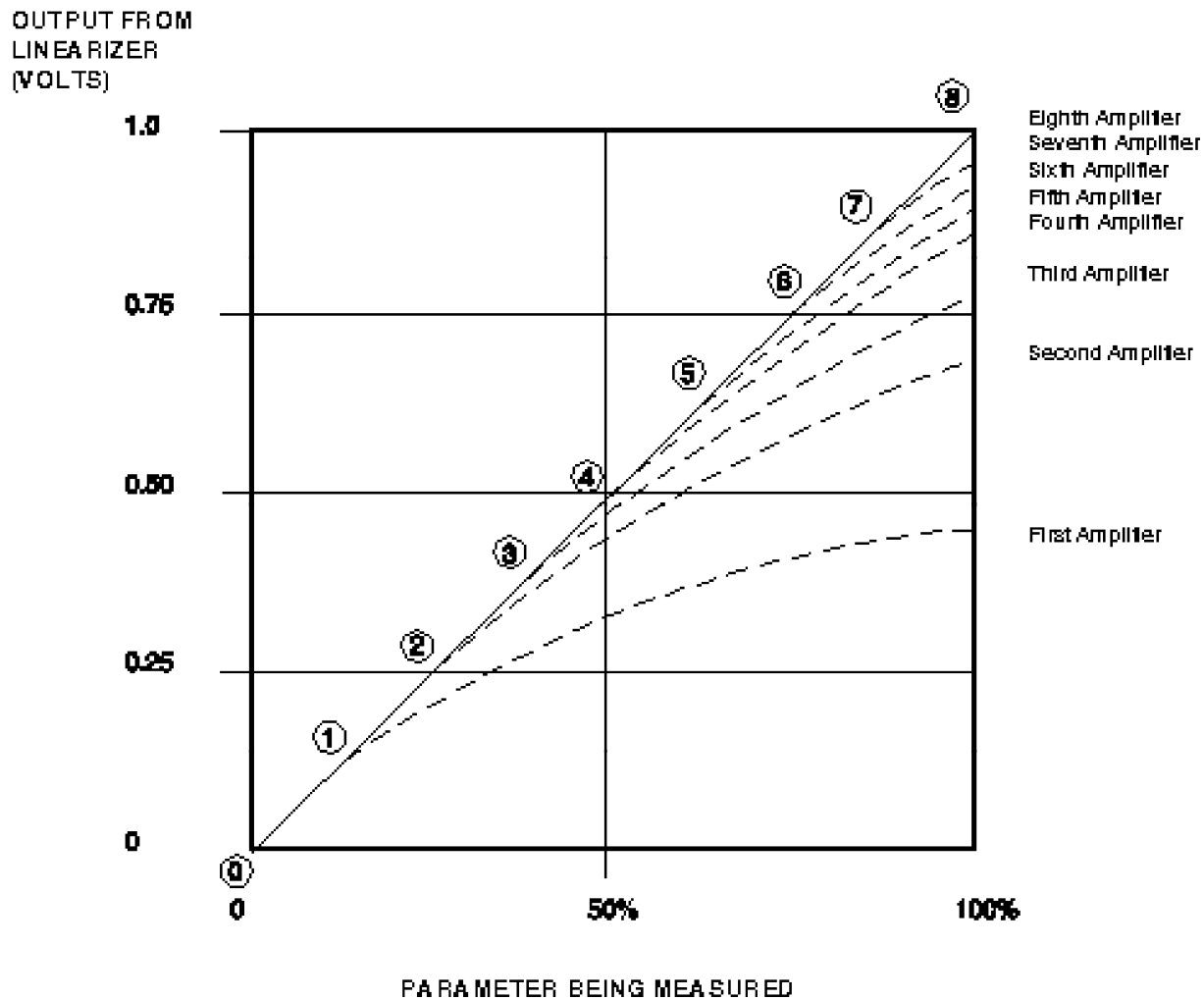

Figure 4-4: The Effect of Each Amplifier on the Final Result
The points labeled 1, 2, 3, etc. are breakpoints.

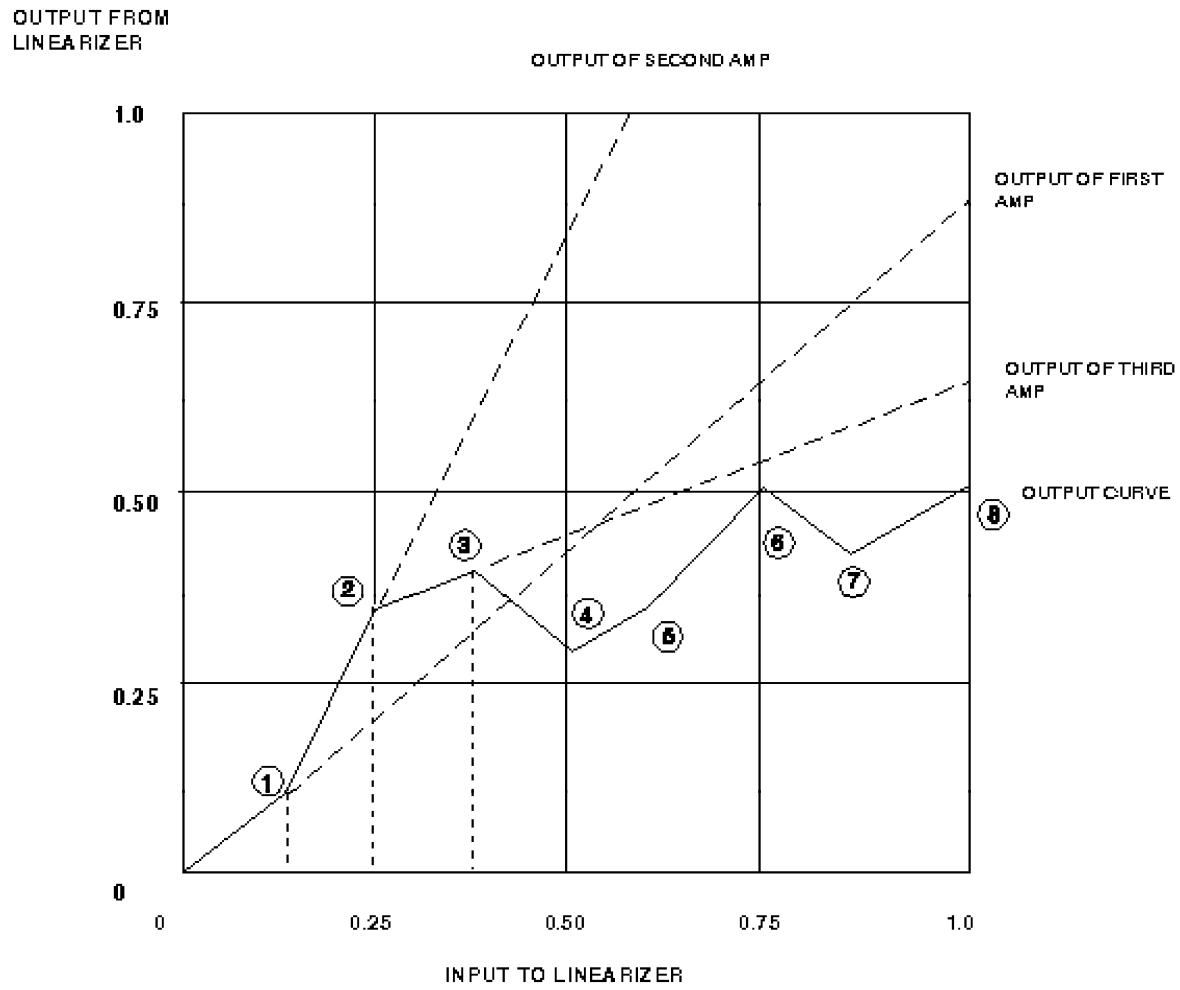

Figure 4-5: Exaggerated Illustration of How the Linearizer Works

When the voltage exceeds 0.25 Volts, the third amplifier works, along with the first two, adding or subtracting its output in proportion, according to the setting of its trimpot, P3. The gain is now the sum of all three gains. In this case, the gain of the third amp is negative, so the total gain is about 0.3.

As the input voltage exceeds each breakpoint, another amplifier joins in. The slope of each line segment is equal to the sum of the gain of all the amplifiers in operation at that particular time. The gain of each amplifier is set by its trimpot. The first amplifier has a gain range of 0 to +4, and all the others about -3 to +3.

The maximum slope obtainable is limited. Setting the gain too high will result in the amplifier saturating. However, with the dynamic range inherent in these amplifiers, this is not likely to happen.

The breakpoints are factory-set by the values of resistors R6, R8, R10, R-12, R14, R16, and R18. See Figure 4-10 for location of these resistors.

The most efficient way to check the operation of the linearizer circuit is to drive it using a 1 kHz. triangular wave of 2 Volts peak-to-peak amplitude as shown in Figure 4-6. The effect of the breakpoints and trimpots can then readily be seen; if you alternate the gain of the stages, a jagged step effect can be produced. This will show the breakpoints clearly. Alternatively, a DVM may be attached to the junction of D2 and R20; this junction point accesses the output of a line segment amplifier. As the input voltage is gradually increased, the DVM at some point will indicate a negative voltage. At this point, a breakpoint has been passed. Repeat this test for each line segment amplifier to determine its breakpoint.

4.2 Linearizer Circuit Theory

Refer to Figure 4-10 for the component position in the following discussion. A1A is a non-inverting buffer and amplifier with a gain of 2.5, zeroed with P9. Its output is checked for zero at test point 1 (TP1). R1 provides a bias path in case the input is not DC-loaded.

The amplified output is brought to the inverting inputs of line segment amplifiers A1B, A1C, A1D, A2A, A2B, A2C, A2D, and A3A, through resistors R5, R7, R9, R11, R13, R15, R17, and R19.

A1D is configured differently from the other line segment amplifiers. It is simply an inverting amplifier with P1 as its feedback resistor to set its gain. The gain for this amplifier may be set between 0 and 4.

The other line segment amplifiers work in a similar fashion. Let us examine A1C, for example. Refer to Figure 4-7 for the following analysis of a typical line segment amplifier.

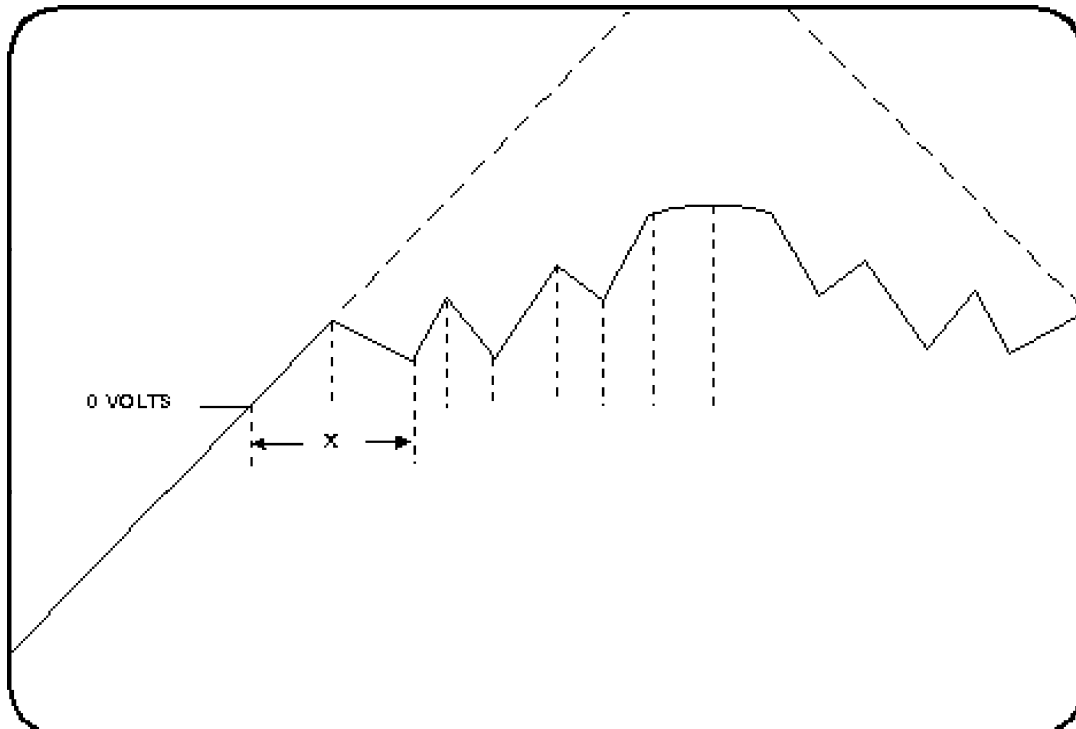

Figure 4-6: Output of Linearizer on Oscilloscope Screen Using Triangle Wave
Notice the mirror image effect as the voltage comes down from its maximum. If the vertical scale and the timebase are arranged so that the slope of the unmodified triangle wave is 45 degrees and the amplitude of the wave is 2 Volts peak to peak, then the value of the breakpoints may be read off the screen by measuring the distance. For example, say the distance measured is X . Then the value of the breakpoint is X times the Volts per centimeter appropriate to the range employed on the Y axis.

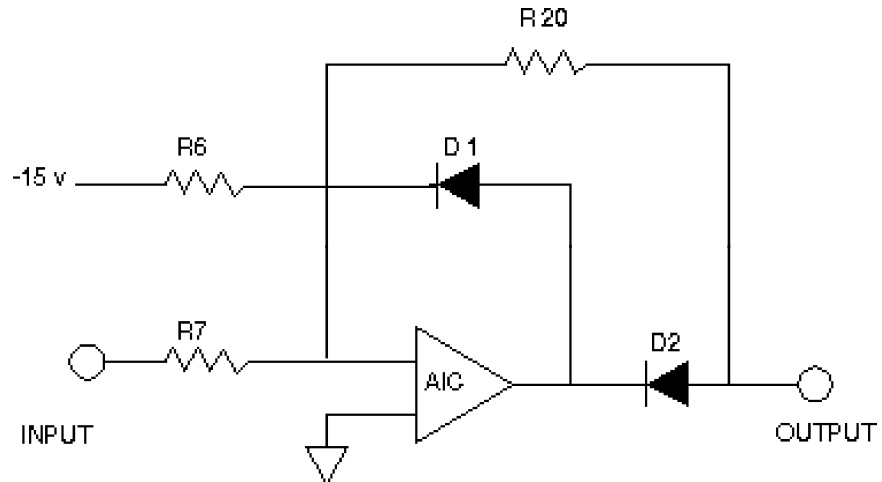

Figure 4-7: A Typical Line Segment Amplifier

Diode D1 effectively shorts the output to the inverting input for any positive-going signals at the output of AIC, while D2 would not allow any positive output at AIC to reach the circuit's output. Negative-going signals, however, do not get through D1, but can go through D2, and R20 then acts as a feedback resistor to set the gain of the circuit (to 4 in the example for AIC). Since D2 is inside the feedback loop, its voltage drop does not appear at the output. R6 sums a fraction of the -15 V supply to the input voltage; the output of the circuit is thus:

$$V_o = -R20 (V_{in}/R7 - 15/R6) \quad \text{for } V_o < 0$$

$$V_o = 0 \quad \text{if } -R20 (V_{in}/R7 - 15/R6) > 0$$

From this it can be seen that the circuit amplifies input voltages above a cutoff voltage, and otherwise has zero output.

$$-R20 (V_{in}/R7 - 15/R6) = 0 \quad \text{or}$$

$$V_{in} = 15 \times R7/R6$$

The negative supply voltage is -15 Volts. A similar expression for the output is $V_{out} = -4(V_{in} - V_{cutoff})$.

Notice that V_{in} is actually 2.5 times the voltage at the linearizer input, due to the gain of A1A. This gain acts to minimize the effect of offset errors.

The cutoff voltage (V_{cutoff}) is set by the choice of R6; the “breakpoint” referenced to the input is approximately $V_{cutoff}/2.5$. Thus:

$$R6 = 15 \times R7 \times 12.5 \times V_{bkpt} \quad \text{or} \quad (299.4 / V_{bkpt}) \text{ K ohms}$$

Note: Each amplifier amplifies everything above its cutoff voltage, and not just a segment between two cutoff voltages.

The output of each amplifier other than A1D is brought to the slider of a trimpot. One end of the pot goes through a resistor (e.g., R28) to the summing node of the output amp, A3B. The other end of the pot goes through another resistor (e.g. R29) to the summing node of the inverter A3C.

The output from the inverter is then also brought into the summing node of the output amp A3B. Clearly the position of the slider on pot P2 will determine how much, signal goes directly into the summing input of A3B, and how much goes through the inverter. If the slider is up at the top, almost all of the output of A1C will add to the output of A1D. If the slider is down at the bottom, then the output of A1C will be subtracted from that of A1D. If the slider is in the middle, the output will be added and subtracted in the same amount and thus will have no effect.

So, we see that the gain of the first section of the curve from 0 to the first breakpoint is set at some value, (A), with P1. The gain of the second section of the curve is the value (A) plus a value (B), which is set by P2. The gain of the third breakpoint then, would be the sum, (A+B), plus a third value, (C), set by P3. In other words, each pot affects the gain of all the sections above where it starts working.

The gain of A3C is kept low by the small value of R43 (2K). This is to stop it from saturating if it gets too much input from all the amplifiers. The resistor that sums its output into A3B, (R44), is selected at 2K to compensate for this.

A3B has a gain of about 0.3 to compensate for the gain of A1A and to reduce zero errors. It also sums all the positive contributions via R44 and A3C. Finally, it provides a low impedance output for the circuit.

4.3 Selection of Breakpoint Resistors

It may be desirable to concentrate the breakpoints in some areas of the voltage range. For example: between 0 and 1 in Figure 4-8, the curve is fairly straight. Between 2 and 3, the curve is modestly straight but with less slope. Between 1 and 2, however, the curve appears substantially curved. Since the linearizer is to approximate the curve with a series of straight lines, we would like to have most of the segments on the curved segment; i.e., between 1 and 2. This means that most of the breakpoints must be between 1 and 2 rather than evenly spaced out. Similarly for the “S” curve shown in Figure 4-9, the breakpoints would be concentrated between the points 1–2 and 3–4.

The resistors for the breakpoints are set according to the formula:

$$R = 299.4/V_{\text{bkpt}}$$

where V_{bkpt} is the voltage at the particular breakpoint.

The resistors affected are R6, R8, R10, R12, R14, R16 and R18 where R6 is the first breakpoint.

ANALYZER OUTPUT

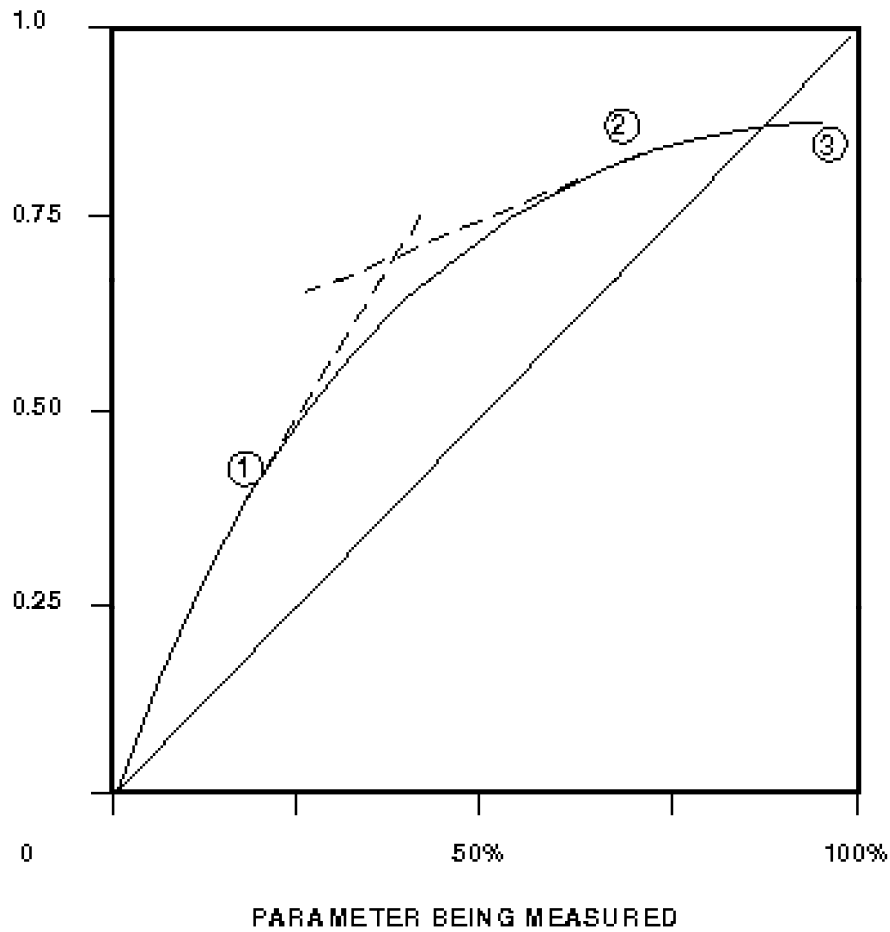

Figure 4-8: A Simple Curve

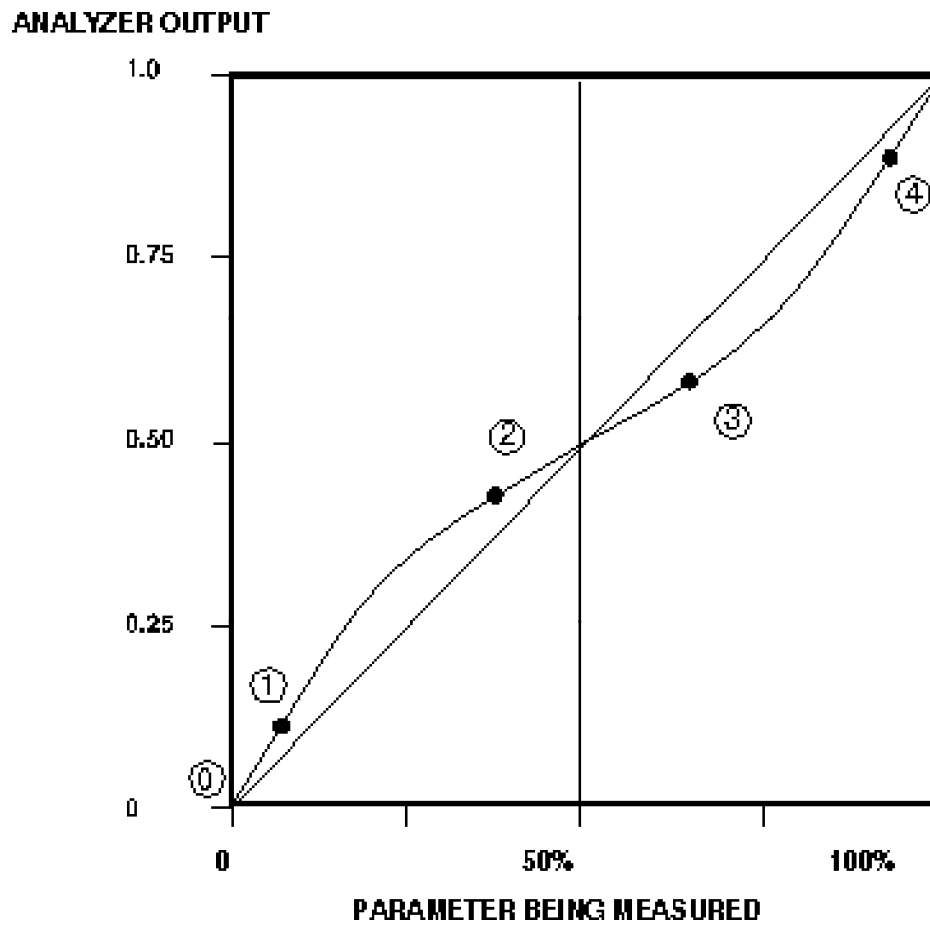

Figure 4-9: An "S" Shaped Curve

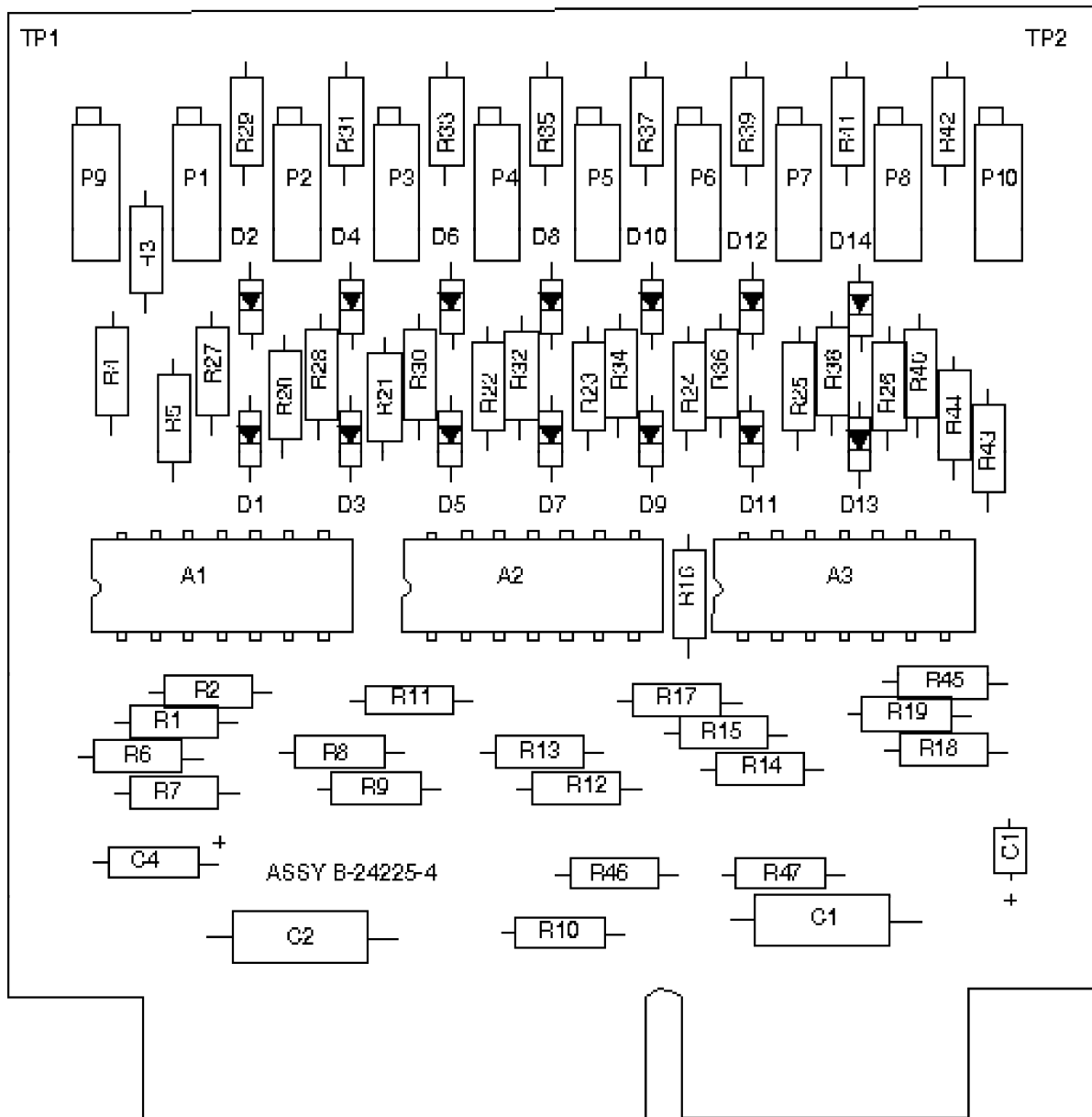

Figure 4-10: Typical Component Placement on Linearizer

4.4 How to Use the Linearizer

Referring to Figure 4-10 for positioning of the Linearizer components, check to see that the proper breakpoint resistors are installed. Also, refer to the Linearizer drawings that have been included in the Appendix.

4.4.1 Nulling Amplifiers A1A

1. Short the input (pin 3) to the common of the diff. power supply.
2. Connect a DVM to TP1 (testpoint 1 is located on the PC board)
3. Adjust trimpot P9 until the DVM reads $0\text{ mV} \pm 10\text{ mV}$.

4.4.2 Nulling the Entire Linearizer Input to Output

1. Maintain the shorted input of A1A. (See step 1 above.)
2. Connect the DVM to the output of the linearizer (pin 7 of A3B).
3. Adjust trimpot P10 until the DVM reads $0\text{ mV} \pm 10\text{ mV}$.

4.4.3 Linearizing the Calibration Curve

The calibration curve must be known at this point and found to be non-linear. This calibration can be done using known samples.

The curve has been studied, and breakpoint positions determined on the most curved portions of the curve. Appropriate breakpoint resistors have been installed.

1. Remove the shorting jumper previously installed for nulling steps.
2. Connect a DC voltage source to the input of A1A (pin 3) and ground. (The DVM is still connected to pin 7 of A3B.)
3. Apply 0 volts to the input, (V_{in}). The output, (V_{out}) must read 0 volts as well.
4. Make $V_{in} = V_{test}(1)$ per chart. This is the first breakpoint voltage. NOTE: V_{in} must always be positive. Adjust P1 until $V_{out} = V_{lin}(1)$ per chart. NOTE: make sure P1 changes V_{out} .

5. Make $V_{in} = V_{test}(2)$ per chart. This is the second breakpoint voltage. Adjust P2 until $V_{out} = V_{in}(2)$.
6. Continue up each line segment, repeating the procedures of the sections just covered, using pots P3, P4, P5, P6, P7, and P8, to linearize line segments 3, 4, 5, 6, 7, and 8.
7. Repeat the calibration against known samples, and verify that the values obtained at various concentrations are linearly displayed.
8. If the linearity is not quite satisfactory, determine which line segment requires touch-up. If more than one segment is not properly adjusted, readjust the segment closest to zero first. All other following segments must be touched up, since they are affected by the former one. If results are still not satisfactory, re-evaluate the breakpoints. Change their positions on the curve as required by installing different values for breakpoint resistors. Repeat the line segment trimpot adjustment procedures as outlined in the above sections.

Appendix

Spare Parts List

QTY.	P/N	DESCRIPTION
1	C-14449	PCBOARD—TEMP CONTROLLER FOR TG OPTION (220V USEC-69410)
1	B-30868	PCBOARD—TEMP CONTROL (220V USEB-36026)
1	B-34856	PCBOARD—AMPLIFIER
1	A-9306	PCBOARD—POWER SUPPLY
1*	C-58991	PCBOARD—LINEARIZER
1*	A-10045	PCBOARD—SINGLE ALARM (-1 OPTION)
1*	A-9309	PCBOARD—DUAL ALARM (-2 OPTION)
1	B-29600	PCBOARD—E TO I CONVERTER, ISOLATED 4–20 mA dc
5	F-10	FUSE, 2A (220V USEF-9)
5	F-75	FUSE, 1/2 A (110V, 220V)
1	H-158	HEATER (110V, 220V)
1	A-31157	CELL ASSEMBLY
1	A-33748	THERMISTOR ASSEMBLY

* These items are options to the standard instrument and unless ordered, will not be present.

IMPORTANT: Orders for replacement parts should include the part number, the model, and serial numbers of the analyzer in which they are to be used.

Orders should be sent to:

TELEDYNE Analytical Instruments

16830 Chestnut Street
City of Industry, CA 91749-1580

Phone (626) 934-1500, Fax (626) 961-2538
TWX (910) 584-1887 TDYANYL COID

Web: www.teledyne-ai.com

or your local representative.

Calibration Data

The following data, along with any Addenda that may be included in the front part of this manual, pertain to your specific Thermal Conductivity Analyzer.

Calibration data for Model: _____
Serial Number: _____
Range: _____
Non-measured components: _____
Output Signal: _____
Reference and Zero Gas: _____

Note: If the zero gas contains a known (or equivalent) impurity, the zero control should be set so that the analyzer indicates the impurity during the standardization procedure.

Span Gas: _____
Selected Resistor Values: _____

Alarm Strapping: _____

Zero Setting: _____

Span Setting: _____