

# MODEL 316RA/RB/RAD/RBD TRACE OXYGEN ANALYZER INSTRUCTION MANUAL

TAI Sales Order Number: \_\_\_\_\_

Model Number: \_\_\_\_\_

Serial Number: \_\_\_\_\_

Micro-Fuel Cell Class: \_\_\_\_\_

Output Signal: \_\_\_\_\_

Ranges: X1: \_\_\_\_\_ ppm Oxygen

X10: \_\_\_\_\_ ppm Oxygen

X100: \_\_\_\_\_ ppm Oxygen

X1000: \_\_\_\_\_ ppm Oxygen

Alarm Set Point #1: \_\_\_\_\_

Alarm Set Point #2: \_\_\_\_\_

P/N M34905  
M38546  
ECO# 02-0046  
2/21/02

---

## Copyright © 1997 Teledyne Analytical Instruments

All Rights Reserved. No part of this manual may be reproduced, transmitted, transcribed, stored in a retrieval system, or translated into any other language or computer language in whole or in part, in any form or by any means, whether it be electronic, mechanical, magnetic, optical, manual, or otherwise, without the prior written consent of Teledyne Analytical Instruments, 16830 Chestnut Street, City of Industry, CA 91749-1580.

### Warranty

This equipment is sold subject to the mutual agreement that it is warranted by us free from defects of material and of construction, and that our liability shall be limited to replacing or repairing at our factory (without charge, except for transportation), or at customer plant at our option, any material or construction in which defects become apparent within one year from the date of shipment, except in cases where quotations or acknowledgements provide for a shorter period. The Micro-Fuel Cell warranty period begins on the date of shipment from Teledyne. Components manufactured by others bear the warranty of their manufacturer. This warranty does not cover defects caused by wear, accident, misuse, neglect or repairs other than those performed by Teledyne or an authorized service center. We assume no liability for direct or indirect damages of any kind and the purchaser by the acceptance of the equipment will assume all liability for any damage which may result from its use or misuse.

We reserve the right to employ any suitable material in the manufacture of our apparatus, and to make any alterations in the dimensions, shape or weight of any parts, in so far as such alterations do not adversely affect our warranty.

### Important Notice

This instrument is intended to be used as a tool to gather valuable data. The information provided by the instrument may assist the user in eliminating potential hazards caused by the process that the instrument is intended to monitor; however, **it is essential that all personnel involved in the use of the instrument or its interface with the process being measured be properly trained in the process itself, as well as all instrumentation related to it.**

The safety of personnel is ultimately the responsibility of those who control process conditions. While this instrument may be able to provide early warning of imminent danger, it has no control over process conditions, and can be misused. In particular, any alarm or control system installed must be tested and understood, both as to how they operate and as to how they can be defeated. Any safeguards required such as locks, labels, or redundancy must be provided by the user or specifically requested of Teledyne when the order is placed.

The purchaser must be aware of the hazardous conditions inherent in the process(es) he uses. He is responsible for training his personnel, for providing hazard warning methods and instrumentation per the appropriate standards, and for ensuring that hazard warning devices and instrumentation are maintained and operated properly.

TAI, the manufacturer of this instrument, cannot accept responsibility for conditions beyond its knowledge and control. **No statement expressed or implied by this document or any information disseminated by the manufacturer or his agents is to be construed as a warranty of adequate safety control under the user's process conditions.**

---

## Table of Contents

<b>Introduction</b> .....	1-1
Features .....	1-1 to 1-2
<b>Operational Theory</b> .....	2-1
Micro-Fuel Cell Sensor .....	2-1
Sampling System .....	2-1
<b>Installation</b> .....	3-1
Location .....	3-2
Gas Line Connections .....	3-2
Input Selector Manifold (Optional) .....	3-2
Pressure Reduction or Regulation .....	3-3
Zero or Near Zero Pressure Sampling .....	3-3
Vent Connection .....	3-3
Electrical Connections .....	3-4
Output Signal Connection .....	3-4
Alarm Relay Connection (Optional) .....	3-4
<b>Operations</b> .....	4-1 to 4-4
Front Panel Controls .....	4-1
Meter Zero .....	4-2
Electrical Start-Up .....	4-2
Sample System Start-Up .....	4-2
Calibration .....	4-3
Alarm Setting (Optional) .....	4-4
Routine Operation .....	4-4
<b>Maintenance</b> .....	5-1 to 6-1
Replacing the Fuse .....	5-1
Replacing the Sensor .....	5-1 to 5-2
Spare Cells .....	5-2
Warranty Conditions .....	5-2
Troubleshooting .....	6-1
<b>Appendix</b> .....	
Specifications .....	A-1
Spare Parts List .....	A-2
Drawing List .....	A-3
Material Safety Data Sheet .....	A3



**DANGER**  
**COMBUSTIBLE GAS USAGE WARNING**



**This is a general purpose instrument designed for usage in a nonhazardous area. It is the customer's responsibility to ensure safety especially when combustible gases are being analyzed since the potential of gas leaks always exist.**

**The customer should ensure that the principles of operating of this equipment is well understood by the user. Misuse of this product in any manner, tampering with its components, or unauthorized substitution of any component may adversely affect the safety of this instrument.**

**Since the use of this instrument is beyond the control of Teledyne, no responsibility by Teledyne, its affiliates, and agents for damage or injury from misuse or neglect of this equipment is implied or assumed.**

---

## Introduction

---

The Teledyne Analytical Instruments (TAI) Series 316 Trace Oxygen Analyzer uses a unique Micro-Fuel Cell to measure the concentration of oxygen in a gas stream. The cell has an absolute zero and produces a linear output from the low parts per million (ppm) level through 21% (210,000 ppm) oxygen. When coupled with a “state of the art” two stage amplifier system that incorporates operational amplifiers, the cell provides linear trace oxygen analysis in the standard ranges of 0-10, 0-100, 0-1000, and 0-10,000 ppm. The cell is specific for oxygen and is not influenced by sample flow rate or the presence of hydrocarbons or halogenated hydrocarbons. The instrument may be calibrated with air, eliminating the need for certified trace oxygen calibration gases.

### Features

**Maintenance-Free Sensor.** Teledyne’s Micro-Fuel Cell oxygen sensor is a sealed electrochemical transducer with no electrolyte to change or electrodes to clean. When the cell reaches the end of its useful life (6 months minimum), simply remove and replace.

**Temperature Compensation.** The Series 316 includes a built-in temperature compensation circuit for greater accuracy.

**Meter Readout.** The Series 316 is equipped with an accurate ( $\pm 0.5\%$  linearity) panel meter which gives direct readout of the analysis. A linear 100-division scale or digital panel meter gives reliable, accurate readout of the analysis at any point on the scale.

**Output Signal.** For applications requiring a continuous recording of the sample oxygen, a linear output signal from 0-1 mVDC to 0-1 VDC is available at no extra charge.

**Multiple Ranges of Analysis.** The Series 316 provides 4 standard ranges of analysis: 0-10, 0-100, 0-1,000 ppm, 0-10,000 ppm, plus a CAL range, which allows instrument calibration using air.

**Speed of Response.** Fast upscale response is a key feature of the Series 316. On the 0-1,000 and 0-10,000 ppm ranges, 90% response time is less than 10 seconds (at constant temperature).

**Compact Packaging.** The Series 316 includes an integral throttle valve, flowmeter, and shutoff valve in a package that uses little more than 10" × 10" of panel space. Access to the major components of the system is gained by opening the front panel door of the instrument case. The micro-fuel cell manifold assembly mounts within the interior, permitting cell replacement without the use of tools.

**Panel or Bulkhead Mounting.** Two standard versions of the Series 316 Series are available. A panel mounted enclosure houses the Model 316RA, and a wall mounted bulkhead enclosure houses the Model 316RB. Both versions share the same features and performance.

#### **Optional Features**

**Current Output Signal.** Grounded or isolated outputs (i.e., 4-20 mADC, 1-5 mADC, 10-15 mADC) can be included in the Series 316 for interface to external devices, such as computers, recorders, etc.

**Integral Alarm Circuitry.** The Series 316 provides independently adjustable control circuits for one or two alarms. The alarms are fully adjustable throughout the scale using the front panel controls.

## Operational Theory

---

### Micro-Fuel Cell Sensor

The Series 316 uses a Micro-Fuel Cell for the measurement of trace oxygen. This Micro-Fuel Cell is an electrochemical transducer whose features include:

- Specificity for oxygen
- Long interval between calibration
- Long life
- Low maintenance
- Disposable configuration

The transducer functions as a fuel cell; in this instance, the fuel is oxygen. Oxygen diffusing into the cell reacts chemically to produce an electrical current that is proportional to the oxygen concentration in the gas phase immediately adjacent to the cell's sensing surface.

### Sampling System

The Series 316 contains a throttle valve and flowmeter for sample path flow control as shown on the Piping Diagram (dwg. B-9051). The integral flow path also features a shutoff valve located downstream from the Micro-Fuel Cell manifold. When closed, these two valves isolate the cell from the high oxygen concentration of air. Before shipment, the sample system is purged with either the customer's background gas (when practical) or an inert gas, such as nitrogen. When the instrument shows a stable, low ppm oxygen level, the two valves are closed, maintaining the cell in a virtually oxygen-free atmosphere until the instrument is installed and ready for use.

**NOTE: To shorten start-up time and conserve cell use, keep the two cell valves closed until installation is complete and sample is flowing.**



## Installation

---

### Precautions

1. Upon receipt of the Series 316 Oxygen Analyzer, inspect the entire unit. **Read the entire installation section before installing the analyzer.**
2. Do not scratch, puncture, or damage the mesh sensing membrane of the Micro-Fuel Cell. Damage to the membrane will require replacement of the sensor.
3. **The Micro-Fuel Cell electrolyte is caustic.** Avoid contact with any fluid or powder in or around the cell or unit. Do not let it come in contact with skin. If it does, immediately flush affected area with water. Consult the Emergency First Aid procedures in the Material Safety Data Sheet at the end of the manual. Do not attempt to open or repair the sensor. Leaking or exhausted sensors should be disposed of in accordance with local regulations. Consult the Material Safety Data Sheet at the end of the manual.
4. The Micro-Fuel Cell must be installed before operating the Series 316.
5. The throttle valve and the shutoff valve should remain closed until the analyzer is installed and ready to use.
6. All accessory hardware and fittings upstream from the analyzer should be leak-tested under pressure before start-up to prevent false readings upon start-up.
7. Check electrical wiring installation against the Interconnection Diagram (dwg. A-33140) before start-up to prevent accidental wiring transposition.

### Location

The Series 316 Trace Oxygen Analyzer should be installed at viewing level in a sheltered area. The analyzer case is not to be considered water tight by the customer.

**NOTE: Auxiliary heating MUST be provided in areas where the ambient temperature drops below 32°F.**

For the location and identification of the gas line, electrical connections, and physical dimensions of the analyzer, see the Outline Diagram (RA: B-40393; RB: C-38551; RAD: B-40400).

After making the panel cutout, TAI suggests line drilling the mounting holes using the analyzer case itself as a template.

### Gas Line Connections

The sample inlet and outlet connections are:

RA: 1/8 " female N.P.T.

RB: 1/8 " tube fitting

RAD: 1/8 " female N.P.T.

TAI suggests using a Teflon sealing tape as a sealant rather than pipe dope. Make sure that mating fittings are not cross-threaded before applying force with wrench.

### Input Selector Manifold (Optional)

A simple manifold is necessary to introduce either sample or calibration (span) gas into the analyzer. TAI recommends the manifold design shown. Span purge and sample purge lines are necessary to flush oxygen accumulated in the lines due to minute leaks. Just prior to switching to either gas source, the respective purge valve should be opened for a short period of time (10-30 seconds). Good quality, 2-way needle valves should be used. Three-way valves may be used but are not recommended.

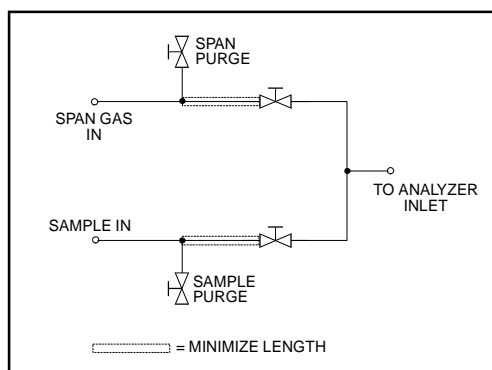

### Pressure Reduction or Regulation

TAI recommends that sample pressure be reduced at the sample point to between 5 and 50 psig (10 psig nominal). If the magnitude of the sample pressure does not exceed 100 psig and is reasonably stable, a simple throttle valve is sufficient. However, if the pressure exceeds 100 psig or oscillates over a wide range, use a **metallic** diaphragm pressure regulator.

**IMPORTANT:** If using a certified composition span gas, equip the supply cylinder with a **metallic** diaphragm regulator.

Using a regulator with an organic diaphragm may allow oxygen to dissolve into the sample or span gas, and will affect readings.

### Zero Or Near Zero Pressure Sampling

In applications where the sample pressure is either zero or near zero, TAI recommends placing a sample pump downstream from the analyzer in vacuum service to draw sample through the analyzer from the sample point. TAI rearranges the integral sampling path (specified at the time of purchase) so that the throttle valve is downstream of the cell. This prevents the cell from experiencing a partial pressure environment and prevents diffusion contamination.

### Vent Connection

The Series 316 Oxygen Analyzer should vent directly to the atmosphere. If venting directly is not possible, install the vent line under the following conditions:

1. The vent line must be constructed of ¼ " tubing (or equivalent), so that no back-pressure resulting from restricted flow occurs.
2. The vent line must end in an area that experiences no more than normal barometric pressure changes.
3. The vent line must be installed so that water and dirt cannot accumulate in it.

### Electrical Connections

Make all customer wiring connections at the terminal strips, located on the motherboard. For the power, output signal, and alarm relay wiring locations, see the Interconnection Diagram (dwg. A-33140).

A source of single phase, 115 VAC, 50 or 60 Hz is needed to operate the Series 316 analyzer (100/220 VAC optional). Polarize the power connections as shown on the Interconnection Diagram (HOT to the "H" terminal; NEUTRAL to the "N" terminal).

An equipment ground wire of the same gauge as the power service (nominally 16-gauge) connects to the terminal identified "G." This connection must be made to give the electronic circuit a proper earth ground reference, and also provides short circuit protection for operating personnel.

### **Output Signal Connection**

The magnitude of the output signal can be preset by TAI from 0-1 mVDC (full scale) to 0-1 VDC (full scale) at the time of purchase. Unless otherwise specified, the output is 0-1 VDC. The output signal, regardless of magnitude, is suitable for driving external devices that have an input impedance of 10,000 ohms or more.

**NOTE: For interconnection purposes, use a 2-conductor shielded cable, particularly for those instruments whose output signal magnitude is in the lower millivolt range. Polarize the signal connections as shown on the Interconnection Diagram, and connect the shield at the analyzer only.**

### **Alarm Relay Connection (Optional)**

The Series 316 may contain one or two fully adjustable alarm contacts. The alarm relays are Form "C" (normally closed-common-normally open) DPDT contacts rated at 3 amperes resistive. The alarm relays are factory set to energize either above or below the set point; a single set point instrument energizes below the set point, and a double set point instrument energizes when the oxygen level reads above set point #1 and below set point #2. Power connections are on the terminal strip.

## Operations

---

### Front Panel Controls

- A) **Meter Readout:** Provides accurate linear 100-division scale or digital readout of the analysis (analog meter labeled 0-10 ppm).
- B) **Range Selector Switch:** Identifies (by the multiplying factor) the basic 10 major divisions of the integral meter scale (i.e. X1 = 0-10 ppm range, X10 = 0-100 ppm range, etc.). For versions with a digital meter, the divisions are 10 ppm, 100 ppm, 1000 ppm, 1%, and 25%.
- C) **Alarm Set 2 potentiometer:** Allows user to set alarm set point (optional).
- D) **Alarm Set 1 Potentiometer:** Allows user to set alarm set point (optional).
- E) **AC Power ON/OFF Switch:** Turns the power on and off.
- F) **Fuse Receptacle:** Contains primary fuse for unit. (Not shown on RB version; located on internal mother board).
- G) **Sample Flowmeter:** Contains throttle valve to regulate sample flow.
- H) **SPAN Potentiometer:** Used for calibrating purposes.
- I) **Cell Shutoff Valve:** Used to shut off the sample flow to the cell. (Not shown on RA version; located on internal piping system).
- J) **Overrange LED:** This LED is provided only on units with a digital meter. The LED lights if the oxygen level is 25% above maximum of selected range. When lit, move the range switch to the next higher range.

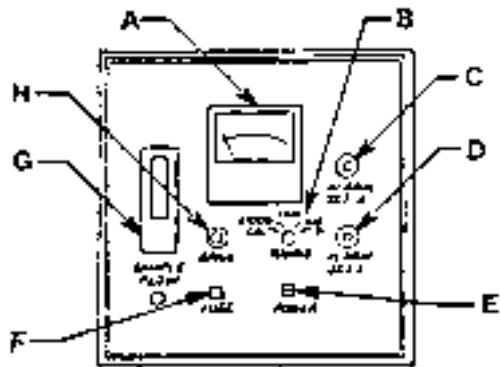

316RA

**Meter Zero**

Before turning the power on, check the mechanical zero of the meter and adjust, if necessary. **Do not adjust the meter with the power on.** The meter pointer should be aligned with the zero mark of the scale. Adjust the screw on the face of the meter until the pointer shows exactly zero. This is important to achieve full advantage of the meter's 0.5% accuracy. Digital meters require no mechanical zero.

**Electrical Start-Up**

Place the range switch in the X-100 scale (0-1000 ppm), and turn on the power. The meter will move upscale and come to equilibrium at a point that represents the concentration of oxygen in the sampling system between the throttle valve and shutoff valve. If the meter reads off scale, refer to the Troubleshooting section.

**Sample System Start-Up**

After establishing power, open the sample gas valve to the analyzer, and start sample flow as follows:

1. Open the cell shutoff valve.
2. Open the throttle valve and set the flowmeter at 2.0 SCFH.

The analyzer should start to respond to the oxygen concentration in the sample gas immediately. Set the range selector switch to the range that gives you the highest resolution of the sample.

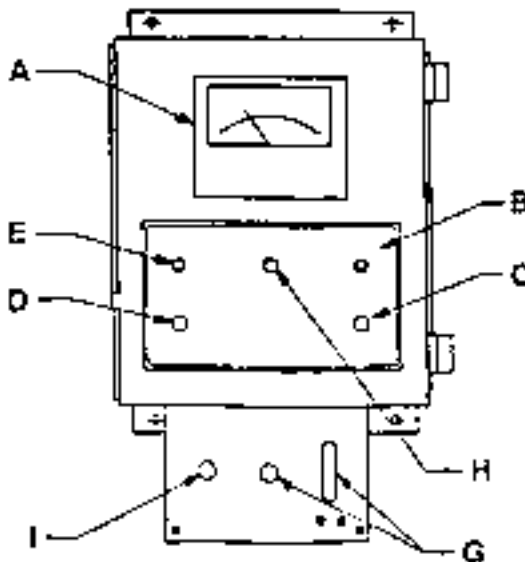

316RB

If air was not permitted to diffuse into the analyzer before the start of sample flow, the analyzer will be ready for calibration.

### Calibration

The Series 316 can be calibrated using a span gas with a known oxygen concentration. Ambient air (20.9%) may be used for calibration, but air calibration requires a longer cell stabilization period before the analyzer can be used for trace analysis. This waiting period can be minimized by calibrating with a span gas with a low oxygen concentration. Air calibration is not recommended when analysis will be performed in ranges of 0-100 ppm or less.

The analyzer can be calibrated on any range. The span gas concentration should be within 70% to 99% of full scale of the range selected.

Prior to calibration, allow the oxygen reading to come to a reasonably stable value (not changing) with zero or sample gas flowing through the analyzer.

To calibrate the analyzer:

1. Move the range selector switch to the selected calibration range. When calibrating with air (20.9%) use the CAL setting (or the 25% range on units with a digital meter).
2. Introduce span gas into the analyzer.
3. Adjust flow to 2 SCFH.
4. Wait for the oxygen reading to stabilize.
5. Unlock and adjust the SPAN potentiometer until the meter reads the oxygen content of the span gas, or aligns with the CAL marking on the dial, if using ambient air to span.  
For digital meters, adjust the SPAN potentiometer until the meter reads the oxygen content of the span gas, or 20.9, if using ambient air to span.
6. Make sure the reading is stable, and then relock the control knob.
7. Re-introduce sample gas into the analyzer.

**NOTE:** Calibration (particularly when the span gas is air) should be performed as rapidly as possible, and the analyzer returned to the sample gas as soon as calibration is complete. The longer the instrument is exposed to the 209,000 ppm oxygen concentration of air, the longer it will require to return to 10 ppm full scale sensitivity.

### Alarm Setting (Optional)

The alarms are set using the adjustable front panel controls, and are fully adjustable (0-100%) in each range. To set the optional alarm(s), use the following example: If the range is 0-1,000 ppm and you want the alarm to activate at 400 ppm, set the alarm dial to 40.0 (40% of 1000 ppm).

### Routine Operation

**Sample Flow.** Adjust to a maximum of 4 SCFH (a nominal level of 2 SCFH is recommended).

**Calibration.** No prescribed routine calibration period is recommended. TAI feels that the intervals between calibration should be dictated by your application. If using the instrument to certify the oxygen content of a product for delivery, then a calibration of the instrument before certification is a good idea. If the instrument is used to monitor or guard a process for predetermined limits of acceptability, use your knowledge of the process and the evidence provided by the instrument to determine when a calibration check is needed. For routine applications in Air Separation and the analysis of inert gases, calibration of the analyzer once per month is adequate to maintain the specified accuracy of the equipment.

**Shutdown.** Whenever it becomes necessary to cut off the sample flow, the following procedure minimizes the diffusion of air into the instrument and helps to maintain the cell in a low ppm oxygen environment.

**CAUTION:** Excessive closing force exerted on the needle valve will damage the valve seat.

1. Close the throttle valve completely.
2. Immediately close the cell shutoff valve.

With the valves completely closed, the output indication will eventually come to equilibrium somewhere on the X100 scale as explained in the first paragraph under Electrical Start-up.

**IMPORTANT:** In the event of loss of flow through the analyzer, if the vent is vented to a location of high oxygen content, oxygen will back diffuse through the vent line and in most cases quickly saturate the cell with oxygen which can then require a quite long purge down time for the sensor when then exposed to low oxygen concentrations. In the event that flow is to be interrupted into the analyzer, it is suggested that the user do one of the following:



1. Bag the sensor in nitrogen during this time
2. Install a shut off valve on the vent port of the analyzer or somewhere within the users sample system.

## **Maintenance**

---

### **Replacing the Fuse**

If the unit will not turn on when plugged in and switched ON (via the power switch), check the fuse:

1. Remove AC power and move the power switch to OFF.
2. Press the front panel fuse receptacle and remove.
3. Slide the fuse out and replace it with a ½A fuse (for 220V use ¼A).
4. Replace the fuse receptacle.

### **Replacing the Sensor**

The characteristics of the Micro-Fuel Cell are similar to those of a mercury battery. Both provide an almost constant output through their useful life, and then fall off sharply towards zero at the end. Cell failure may show by the inability to properly calibrate the analyzer when using span gas. Very little adjustment of the 10-turn SPAN potentiometer will be required to calibrate the analyzer during the duration of a given cell's useful life. If several turn adjustments (span control) are required to calibrate the instrument, or calibration cannot be achieved within the range of the control, replace the Micro-Fuel Cell.

The cell is located behind the hinged front panel inside the cell block assembly. To replace the cell:

1. Move the range selector switch to CAL. Make sure the power switch is OFF.
2. Make sure sample is flowing through the analyzer. Shut off the flow and remove the old cell by unscrewing counter-clockwise the plug at the bottom of the cell block (the cell will drop out when the plug is removed).

**NOTE: It is important to minimize the amount of time that the new cell is exposed to air in order to reduce the time required for the reading of the newly installed cell to drop to zero.**

3. Remove the new cell from its package, remove the shorting clip, and position it on the cell block plug (contact plate surface up). Take care that the cell does not come off the plug flange and that the flange does not scrape across the sensing membrane, which will render the cell unusable.
4. Insert the cell into the cell block and tighten the cell block plug to seat the o-ring seal.
5. Immediately start sample flow, and set at 2 SCFH.
6. Allow the reading to drop to a stable low value and immediately proceed to the Calibration section.

### Spare Cells

If you wish to prevent the possibility of not having a replacement cell available when needed, order a spare cell shortly after placing the Series 316 in service, and after each time the cell is replaced.

**NOTE: Do not stockpile spare cells. Only one cell per instrument should be in reserve.**

The spare cell should be stored in an area free from large variations in ambient temperature (75°F nominal), or any possibility of damage. **Do not open the cell package until the cell is to be used.** If the cell package is punctured and air permitted to enter, the cell will immediately start to react to the presence of oxygen, shortening cell life.

### Warranty Conditions

The Class B-2 cell used in the Series 316 is warranted for six (6) months of service beginning from date of shipment. The B-2 cell should not be used in applications where CO<sub>2</sub> is a major component in the sample. Concentrations of 1,000 ppm or less will not affect cell performance. Optional cells are available for either intermittent or continuous CO<sub>2</sub> exposure.

Customers having warranty claims should return the cell in question to the factory for evaluation. If it is determined that failure is due to faulty workmanship or material, the cell will be replaced free of charge.

**NOTE: Evidence of tampering or mishandling will render the cell warranty null and void.**

If a cell was working satisfactorily, but fails short of its warranty period, the customer will receive credit, on a pro-rated basis, toward the purchase of a new cell.

**Troubleshooting**

Most problems that may occur can usually be resolved by verifying instrument setup against the procedures provided in the “Installation & Start-Up Procedures” section. If this does not result in proper operation of the Series 316, the following checks in this section are to be made. If the problem still cannot be resolved, contact TAI. If you cannot identify the problem, or if you cannot resolve the problem after following the corrective procedure, call a service representative.

Symptom	Correction
<b>No response from meter.</b>	<ul style="list-style-type: none"> <li>a) Check fuse.</li> <li>b) Check for <math>\pm 15</math> VDC at test points on oxygen amplifier PCB (B-32129), or the E/I power supply PCB (A-9306) if the current output option is installed.</li> <li>c) Check output at A1 and A2 (pin 6) on the oxygen amplifier PCB (B-32129). If no output, call TAI.</li> </ul>
<b>Meter gives wrong reading.</b>	<ul style="list-style-type: none"> <li>a) Turn power off. Check mechanical zero (analog meter only).</li> <li>b) Turn power on. Let reading stabilize. Increase flow rate to 4 SCFH and watch meter. If the reading decreases, find and correct leak. If reading increases, look for a restriction in sample lines or vent. Open shutoff valve completely.</li> <li>c) Turn power off, remove wires from terminals 1 and 2 on the small terminal strip on the oxygen amplifier PCB (B-32129) and short together. Turn power on and set range to X1. Meter should read 0. Reconnect terminals 1 and 2 and allow reading to stabilize. If reading is still incorrect, replace sensor.</li> </ul>
<b>Analyzer will not span to CAL mark (or 20.9) when using ambient air to span.</b>	<ul style="list-style-type: none"> <li>a) Make sure correct sensor class installed.</li> <li>b) Replace sensor.</li> </ul>
<b>Analyzer reads over 1000 ppm at Electrical Start-Up.</b>	<ul style="list-style-type: none"> <li>a) Wait a little longer until reading completely stabilizes. If the reading is still high, replace sensor.</li> </ul>



## Appendix

---

### Specifications

<b>Ranges:</b>	Standard: 0-10 ppm, 0-100 ppm, 0-1,000 ppm, 0-10,000 ppm, CAL oxygen Digital: 0-10 ppm, 0-100 ppm, 0-1,000 ppm, 1%, 25%
<b>Sensitivity:</b>	0.5% of full scale
<b>Accuracy:</b>	±2% of full scale at constant temperature (except ±1 ppm for 0-10 ppm range) ±5% of full scale over the operating temperature range (except ±1 ppm for 0-10 ppm range)
<b>Response Time:</b>	At 77°F (25°C): 0-10 ppm, 90% in less than 45 seconds 0-100 ppm, 90% in less than 30 seconds 0-1000 ppm, 90% in less than 10 seconds 0-10,000 ppm, 90 in less than 10 seconds
<b>Operating Temperature:</b>	+32°F to +125°F (0°C to +52°C)
<b>Micro-Fuel Cell Class:</b>	B-2
<b>Micro-Fuel Cell Warranty:</b>	6 months
<b>Voltage Signal Output:</b>	0-1VDC or less (standard)
<b>Current Signal Output:</b>	1-5, 4-20 or 10-50 mADC (optional)
<b>Alarm Output:</b>	(Optional) 1 or 2 DPDT Form C relays (3A resistive)
<b>Alarm Deadband (Hysteresis):</b>	0.1% of full scale
<b>Power Requirement:</b>	115 VAC, 50/60 Hz, 30 W (100/220 VAC optional)

---

**Spare Parts List**

<b>Qty</b>	<b>P/N</b>	<b>Description</b>
1*	B29600	PCB, E-to-I Converter, Isolated
1*	B14702	PCB, E-to-I Converter, Neg. Ground
1*	A10045	PCB, Single Alarm
1*	A9309	PCB, Dual Alarm
1*	B43812	PCB, Cell Failure Alarm
1*	B30868	PCB, Temp. Controller (115V)
1*	B36026	PCB, Temp. Controller (220V)
1*	B30717	PCB, Digital Meter
1	A9306	PCB, Power Supply
1	C32129	PCB, Oxygen Amplifier
1	R179	Relay (used with alarms)
1	O165	O-Ring
5	F75	Fuse - 1/2A (220V use F-6)
1	C6689-B2	Micro-Fuel Cell

\* Optional equipment

A minimum charge is applicable to spare parts orders.

**IMPORTANT: Orders for replacement parts should include the part number and the model and serial number of the system for which the parts are intended.**

Send orders to:  
TELEDYNE ANALYTICAL INSTRUMENTS  
16830 Chestnut Street  
City of Industry, CA 91749-1580  
Telephone: (626) 961-9221  
TWX: (910) 584-1887 TDYANYL COID  
Fax: (626) 961-2538  
or your local representative

---

**Drawing List*****RA Version:***

B-40393 Outline Diagram  
B-9051 Piping Diagram  
C-35078 Schematic  
C-31945 Schematic, Mother Board PCB  
B-32152 Schematic, Oxygen Amplifier PCB  
A-33140 Interconnection Diagram

***RB Version:***

C-38551 Outline Diagram  
A-23205 Piping Diagram  
C-35078 Schematic  
C-31945 Schematic, Motherboard PCB  
B-32152 Schematic, Oxygen Amplifier PCB  
A-33140 Interconnection Diagram

***RAD version:***

B-40400 Outline Diagram  
B-9051 Piping Diagram  
C-41964 Schematic  
C-37707 Schematic, Motherboard PCB  
B-37731 Schematic, Oxygen Amplifier PCB  
B-30719 Schematic, Digital Meter PCB  
C-45424 Wiring Diagram  
A-33140 Interconnection Diagram

**NOTE:** The MSDS on this material is available upon request through the Teledyne Environmental Health and Safety Coordinator. Contact at (626) 934-1592, Fax: (626) 961-2538 or (626) 934-1651

